



ProLine

Item no. 2007-2

Rev-B

3000 Watt AC Inverter

V2.0



User's Manual

Thank you for purchasing this 3000 Watt DC to AC ProLine Power Inverter by Wagan Tech. With minimal care and proper treatment it will provide years of reliable service. Carefully read, understand and comply with all instructions before use. Keep this manual for future reference.

ABOUT THE INVERTER

This power inverter converts 12 volts, direct current (12V DC) to 115 volts alternating household current (115V AC). It easily powers TV/VCR combinations, microwave ovens, refrigerators and small air conditioners. It also operates at the highest efficiency (up to 90%) that results in longer running times and extended battery life compared to other inverters with this level of power output.

This inverter has the highest surge capability in its class. Superior surge capability allows the inverter to start most difficult motorized loads. Advanced circuitry runs cooler and is more reliable than competing units.

GENERAL INSTRUCTIONS:

- Keep the inverter away from any direct heat source or combustible materials.
- Keep well ventilated – this device generates heat.
- Keep the inverter away from combustible fuel or battery gases.
- Do not continuously operate any equipment over 3000 Watts.
- This inverter operates from a 12 volt DC power source only.
- Do not attempt to connect the inverter to any other power source, including any AC power source.
- Incorrect battery polarity will damage the inverter and void the warranty.
- Keep this inverter in a dry environment.
- Do not open the inverter; there are no user serviceable parts inside.

LOAD CONSIDERATIONS

When an appliance with a motor starts, it requires a momentary surge of power. This surge of power is the “starting load” or “peak load”. Once started, the appliance requires less power to continue to operate. This is known as the “continuous load”. It is important to know starting loads and continuous loads of appliances that will be powered by the inverter.

Appliance power is rated in watts. This information is usually stamped or printed on most appliances and equipment. In some cases, a tool will be rated in amperes. To convert from amps to watts, multiply: $AMPS \times 115 \text{ (AC voltage)} = WATTS$. This formula yields an approximation of the continuous wattage load of that appliance.

The startup load of an appliance is a major factor of whether this inverter can power it. Startup load is momentary. With many appliances, it is approximately twice the continuous load but some appliance startup loads can be as high as eight times the continuous load. To determine if an appliance or tool will operate with this inverter, run a test. This inverter will automatically shut down in the event of an output overload, so there is no danger of damaging either the inverter or the equipment.

This inverter may not properly operate some appliances with either speed control features or dimmer controls. Some appliance GFCI power cords will not operate properly while powered by this inverter. The only way to be sure of proper operation is to try it.

SAFETY WARNING: THE INVERTER OUTPUT CAN BE LETHAL. IMPROPER USE OF THIS INVERTER MAY RESULT IN PROPERTY DAMAGE, PERSONAL INJURY OR LOSS OF LIFE.

FRONT PANEL

The Front Panel contains the inverter's ON/OFF Switch, Digital Indicators, direct wiring High Current Terminals, Two AC Outlets and a Remote Switch Connector for connecting an optional Remote Switch cable.

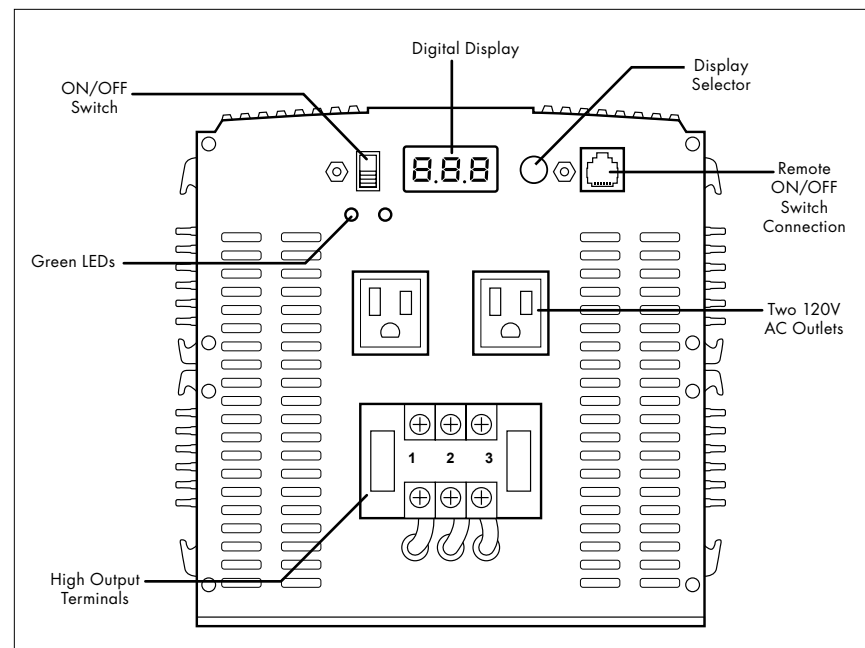

On/Off Switch

This switch turns the inverter on and off.

Digital Display, Function Button, and Green LEDs

The inverter is equipped with a digital display to monitor input DC volts, DC amps, AC output watts and error codes. A Display Selector button allows the user to advance the display readout to the next readout. The lit/unlit status of two green LEDs show which function is being shown on the Digital Display

The display and button are used to help diagnose problems if they occur.

Green LEDs Status (Shows Display Mode, ☼ = Lit, ○ = Unlit)

LEFT LED	RIGHT LED	DISPLAY Mode
○	☼	DC Input Voltage
☼	○	DC Input Current (Amps)
☼	☼	AC Output Wattage (Kilowatts)
○	○	Diagnostic Codes (E01, E02, E03, E04)

Volts Readout – Digital Display (left LED unlit, right LED Lit)

The volts display is the measurement of the voltage at the DC terminals of the inverter, not actual battery voltage. During high wattage applications the display may show a lower voltage level than the battery because of a voltage drop that can occur between the DC input cables and the battery. This voltage drop should not be greater than 0.25 to 0.5 volts, as a greater voltage will seriously reduce run time. This inverter will operate with input voltage ranging from 10 to 15 volts of direct current (DC). If the inverter input voltage level falls to 10.5 volts DC, an audible alarm will sound. When the voltage drops below 10 volts DC, the inverter will automatically shut down.

During charging from a generator, solar panel or AC powered charger the battery voltage will be higher than when it is resting. This inverter will automatically shutdown if the input voltage is 15 volts or higher. Voltages greater than 15 may cause damage to the inverter. Damage caused by excessive voltage input is not covered under the warranty.

Amps Readout – Digital Display (left LED lit, right LED unlit)

This readout indicates actual DC amperes of current being drawn from the battery bank. Note that for a 120 amp reading the inverter should be powering 1200 watts of AC load.

Watts Readout – Digital Display (both left LED and right LED lit)

The Watts readout shows AC watts delivered to the connected operating AC appliance load.

Diagnostic Error Codes – Digital Display (both left LED and right LED unlit)

When diagnostic codes are selected for display, the user will see four “Error Codes” designated as E01, E02, E03 and E04. These codes are associated with a reason for inverter shut down. Their meanings are as follows:

- E01 – Overload
- E02 – Over Temperature
- E03 – Low Battery
- E04 – Over Voltage

High Output AC Terminals

There are three insulated terminals on the front panel of the inverter. These terminals are for connecting 115 volt AC devices that require more than 15 amps to operate. Other uses are for connection to distributed wiring that has multiple AC outlets. Any wiring that is directly connected must be 10 gauge or larger. Facing the Front Panel, the terminals are:

Left	Middle	Right
Ground	Neutral	Hot or Live

Neutral and Ground are bonded inside the inverter to comply with the National Electric Code (NEC) requirement that any AC source must have a Neutral to Ground connection.

Two 115V AC Outlets

Each outlet will supply up to 15 amps 115V AC maximum, for powering appliances. Greater than 1650 watts continuous power from an outlet may cause damage to the inverter and cause possible injury. Use the high output terminals for appliance loads greater than 15 amps.

Remote On/OFF Switch Connection

A supplied cable and Remote Switch assembly provides a convenient remote On/Off feature.

Power Inverter Output Waveform

This inverter’s AC output is a modified sine wave (MSW) 115 volts AC. The comparison of modified sine wave and household AC is shown in the figure below.

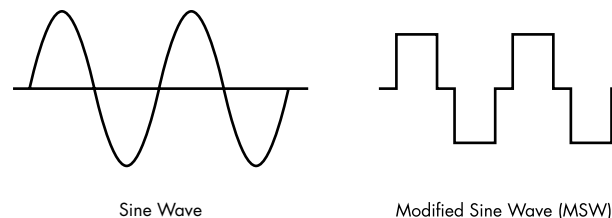

This modified sine wave has a root mean square (RMS) voltage of 115 volts. Most ordinary AC voltmeters are calibrated to read "average" voltage and assume that the AC waveform will be a pure sine wave. These meters will not correctly read MSW voltage, and will display about 20 to 30 volts too low. Any multi-meter identified as "TRUE RMS" will accurately read MSW correctly.

REAR PANEL

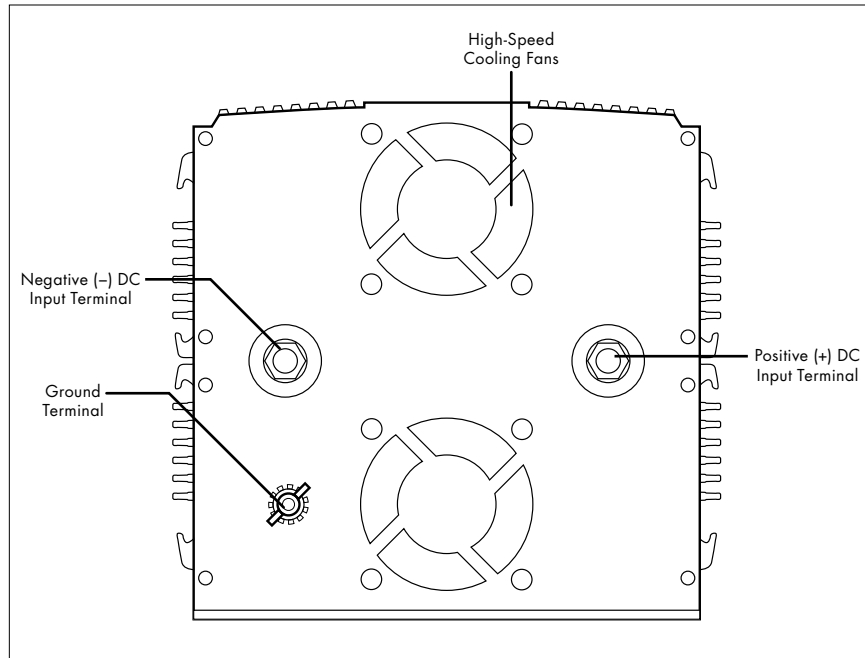

High-Speed Cooling Fans

Two high-speed fans keep the internal temperature of the inverter within operating limits.

Negative DC (-) Input and Positive DC (+) Input Terminals

DC input terminals are used to connect the inverter to heavy duty cables from the battery or battery bank. For connection information, refer to the sections on installation.

Ground Terminal

This connection is located on the lower left of the rear panel. It is for attaching a 6 gauge insulated safety ground wire. This safety wire is for protecting personnel if there is an unlikely failure in either the cabling or enclosure insulation. Do not directly connect this ground connection to the negative DC terminal. This safety wire is to be connected to the vehicle frame or earth ground. This is described in the installation procedure.

PLANNING THE INVERTER SYSTEM

Any large wattage inverter system requires planning before installation. There are several steps to the planning process so the user must determine the following:

- Maximum inverter wattage required
- Operating time (run time) needed between battery recharges
- Battery bank capacity in amp-hours
- Charger requirement to charge batteries within a practical time.
- Distance between battery bank and inverter.

DETERMINING MAXIMUM APPLIANCE WATTAGE

Maximum AC appliance wattage is the first factor in planning battery and charging systems.

Some background: Large microwave oven specifications list cooking power (watts) and appliance power. Appliance power is the AC load the inverter has to supply.

Most other electrical tools, appliances and audio/video equipment have labels that list the unit's power requirements in watts. If the tool or device is rated in amps, multiply the amps by 115 (115V AC) to determine the watts. For example, a power tool rated at 4 amps will draw 460 watts.

Determine the wattage of each appliance you need to simultaneously operate. Add all of the appliance wattages to obtain an estimated "total watts" number. Remember to consider the startup surge that motorized appliances will cause. Do not exceed the surge rating of this inverter (6000 watts). This can cause immediate an overload shutdown.

At 3000 watts continuous output, this inverter requires a DC power supply (battery bank) that can continuously supply 300 amps at 12V DC for the duration of the run time.

CONFIGURING THE BATTERY BANK

To determine the minimum battery ampere-hour rating that you will need to operate appliances from the inverter, and any DC appliances powered by the battery bank. Follow these steps:

1. List the maximum continuous wattage that the inverter has to supply.

- Estimate the number of hours the appliances will be in use between battery recharges. This will vary depending on appliances. For example, a typical home use coffeemaker draws 500 watts during its brew time of 5 minutes. It maintains the temperature of the pot, requiring 100 watts. Typical use of a microwave oven is only for a few minutes. Some longer operating time appliances are lamps, TVs, computers and refrigerator/freezers.
- Determine the total watt-hours of energy needed. This is done by multiplying average power consumption in watts by hours of run time. For example: 1500 watts for 10 hours = 15,000 watt hours.

To get an estimate of the maximum current (in amps) that a battery bank must be capable of delivering to the inverter, divide the load watts by ten. For example a 1500 watt appliance load will need 150 amps at 12 volts DC.

Using the 1500 watts (or 150 Amps) for 10 hours example as above, then 150 amps is needed for 10 hours. This provides us with the basic amp-hours (AH) of battery that is required. Ten hours at 150 amps equals 1500 amp-hours (AH). This answer is just a beginning because there are additional factors that determine actual run time. These include:

- AC appliance load and time in use (basic AH)
- Cable gauge and length (cable losses)
- Charge level of the batteries (between use, chargers have to be able to fully charge the batteries)
- Temperature of the batteries (colder batteries provide fewer amps)
- Age and condition of the batteries (older batteries lose AH capacity)
- Compliance with turning off unnecessary AC loads.
- Use of DC appliances and compliance with turning off unnecessary DC loads.

DERATING THE BATTERY BANK

Most lead-acid batteries have a rating expressed in amp-hours (AH). The most common rating of AH is "at the 20 hour rate".

NOTE: Despite several Internet explanations, here is no relationship between Cold Cranking Amps (CCA) and Ampere Hours (AH).

For example; if a 20AH battery is discharged at a 1 amp rate, it will take 20 hours to discharge that battery. The terms "charged" and "discharged" relate to actual battery voltage. This means that the output voltage of a nominal 12 volt battery starts at 13.2 volts (fully charged) then drops to 10.6 volts (discharged). If the load on the battery causes the battery to discharge faster than the 20 hour rate, the capacity (AH) of the battery is measurably reduced (derated). Derating is a major run time factor. The curve in the following chart can help to determine what the battery bank can deliver under load. The results are used to estimate how much additional battery capacity is needed to achieve the desired run time.

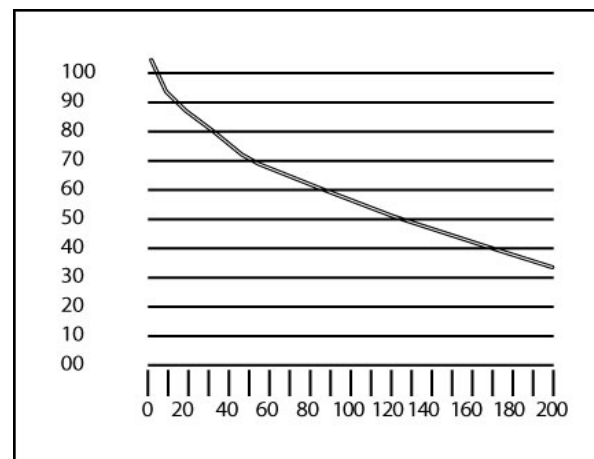

The left vertical numbers of the curve represents percentage of the battery capacity at the 20 hour rate. In this example, the user needs a one hour run time. If the example battery is 220AH (20 hour rate), and the load is 220 amps that is 100 percent (horizontal number) of the AH (20 hour rate). Starting at the 100 percent horizontal point and looking up to the curve the results are that only 56 the percent of the battery capacity is available. This means that a higher battery capacity is required to get the desired run time, one hour. The curve also shows that a load of 200 percent of the 20 hour rate yields only 31 percent of the battery capacity. The installer must carefully plan the capacity of battery bank or the run time may be seriously affected. To the inexperienced installer, several trial battery capacities may be required to make sure the large enough battery capacity is available to achieve the desired run time.

The curve can be applied to any lead acid battery under load providing that it has an AH rating at the 20 hour rate.

Continuing with the example above: The 150 amp load will need to run for 10 hours, so we begin configuration with a 1500 AH battery. If the vertical is 1500 and the horizontal is 150 amps, the percentage of load on the battery is 10 percent. The curve shows that the 1500 AH is derated to 90 % of maximum. This means that the battery will have to be 16500 AH for the full 10 hour run time. It is important to add some extra battery capacity, because as the batteries age, they will lose AH capacity.

CONFIGURATING THE BATTERY BANK

Six volt, 220 AH "golf cart" batteries were selected for these illustrations because they are generally readily available and relatively inexpensive. They are deep-cycle type and with regular recharging they have a relatively long life. These batteries are "flooded" type; they freely vent hydrogen and oxygen while under charging and heavy discharge. They must be vented to outside air to prevent accumulation of explosive gases.

BATTERY BANK DIAGRAM

The diagram below shows inverter connections to a battery bank with recommended fuse protection.

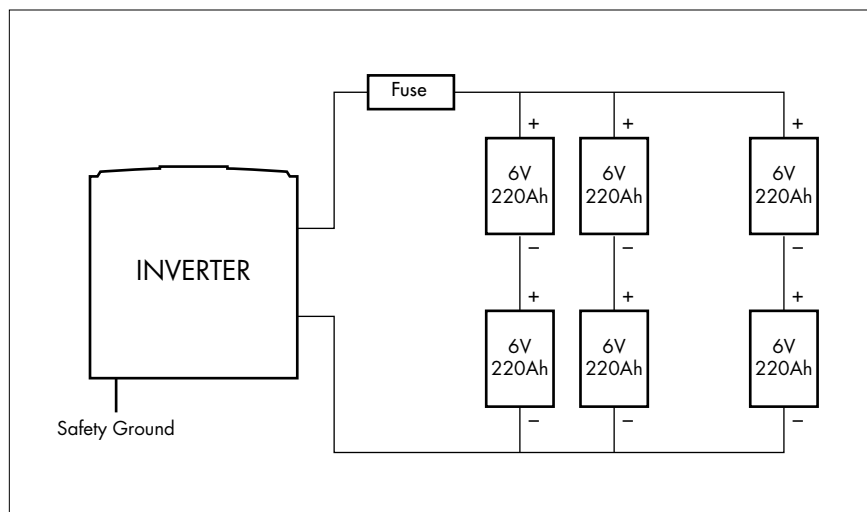

FUSING REQUIREMENTS

NOTE: It is important that this 3000 watt inverter has one ANL 400 ampere or equivalent main battery fuse added to the Positive (+) battery cable as close as possible to the battery bank's positive terminal. The fuse amperage rating must be sized to allow simultaneous operation of all the AC appliances to be powered, allowing for the momentary high startup current requirements of inductive loads. Use the recommended fuse block (fuse holder) and fuse, or an electrical equivalent. ANL type fuses and fuse holders are readily available from marine supply dealers.

The 400 amp battery protection fuses is very important to protect equipment, batteries and personnel. The fuses protect against battery explosion if the cables that connect to the inverter accidentally short.

READ AND COMPLY WITH THE WARNING BELOW.

WARNING

EXPLODING BATTERIES CAN SPRAY MOLTEN LEAD, HOT SULFURIC ACID AND OTHER METAL AND PLASTIC FRAGMENTS. BATTERIES THAT ARE CHARGING OR UNDER HIGH DISCHARGE RATES PRODUCE EXPLOSIVE HYDROGEN GAS INTO THE SURROUNDING AREA. BE SAFE— FUSE THE BATTERY BANK AND MAKE SURE THE BATTERIES ARE PROPERLY VENTILATED.

DC Cable Gauge

Minimize cable losses by using the thickest wire available, and the shortest practical length. If the inverter and the battery are positioned within four feet of each other, a minimum of 0 gauge (zero gauge) insulated copper wire should be used to make the connections. If the round trip distance is longer than 4 feet, heavier wire will be required.

CONNECTING THE INVERTER

General information

Loose connections will result in a severe voltage drop that can cause damage to connectors, conductors, and insulation and can cause sparking. Make sure all cables are the proper gauge and plan to have the ANL fuse holder within one foot of the battery bank's Positive (+) terminal. All cable ends need to be stripped of insulation for approximately $\frac{3}{4}$ of an inch to have appropriate sized ring terminals crimped onto the bare cable ends. Appropriately sized socket wrenches should be used to carefully tighten the retaining nuts on the terminals of the battery bank, fuse holder and DC terminals on the back panel of the inverter.

CAUTION: Reverse polarity connection will blow the fuses in the inverter and can permanently damage the inverter. Damage caused by reversed polarity will void the warranty.

Procedure

1. Connect the Negative (-) cable ring terminal to the Negative (-) Battery Terminal.
2. Install the ANL fuse in the Fuse holder Positive (+) cable.
3. Make sure the ON/OFF switch located on the front panel of the inverter is in the OFF position. Disconnect any remote switch from the connector on the front panel.
4. Locate the Ground Lug Terminal at the rear of the inverter. Connect an insulated 6 gauge copper wire to the terminal. The other end of the ground wire is connected to a "proper" grounding point. Use the shortest practical length of wire. Connect this wire to the chassis of your vehicle or to the grounding system in your boat. In a city, the ground wire can connect to a metal cold water pipe that goes underground. In remote locations, the ground wire can be connected to an "earth ground". This can be an attachment to a 6 foot long copper clad metal rod driven into the ground. In the unlikely event of a short circuit, operating the inverter without proper grounding can result in electrical shock. Do not directly connect this ground

wire to the Negative DC Terminal. You can connect the ground wire to the negative battery terminal.

NOTE: The cable ends need to be stripped of insulation for approximately $\frac{3}{4}$ of an inch at both ends. The battery ends or fuse end needs to have ring terminals crimped onto the bare cable ends.

5. Use a socket wrench to loosen and remove the Positive (+) and Negative (-) cable connector retaining nuts. Place the Negative (-) cable ring terminal onto the Negative (-) DC terminal. Place the retaining nut on the terminal stud. Use the socket wrench to make a good, secure connection.
6. Recheck and make sure the DC cable fuse is installed in the fuse holder.
7. Attach the Positive (+) DC cable to the Positive (+) terminal on the battery. Avoid shorting the socket wrench and carefully tighten the retaining nut.

CAUTION: Making an initial connection between the positive cable and the inverter's positive terminal may cause a spark. This is a normal and is a result of capacitors in the inverter starting to charge. Because of the possibility of sparking, it is extremely important that both the inverter and the battery bank be positioned away from any source of flammable fumes or gases. Failure to heed this warning can result in fire or explosion. Do not make the positive terminal connection immediately after the batteries have been charging. Allow time for the battery gasses to vent to outside air.

8. Attach the positive cable ring terminal to the Positive (+) DC connector stud on the inverter. Replace the retaining nut and carefully tighten. Make sure the connection is tight and secure.
9. Turn on the inverter. Advance the Digital Display to the Voltage display (right green LED lit) by pressing the FUNCTION button. The display on the front panel should show 10.5 to 13.2 volts depending on the voltage of the power source. When the voltage reading does not fall within this range, check the connections of the wires to the terminals on the battery bank and the inverter to make sure they are secure. Also check the voltage of the power source. Advance the Digital Display to the Diagnostic Error Codes (green LEDs not lit). Look for code E03: Low Voltage Shutdown. If this code is present, then check for loose connections of discharge batteries.
10. Turn off the inverter. The audible alarm may sound a short "chirp". This is also normal.
11. When you have confirmed that the appliance to be operated is turned off, plug the appliance into one of the two AC outlets on the front panel of the inverter.
12. Turn the inverter on.
13. Turn the appliance on.
14. The Remote On/Off switch should be placed in a location convenient to the user. Insert the cable plug into the front panel connector. The inverter's Front Panel On/Off Switch must be On for the Remote Switch to operate. A lit LED indicator on

the Remote Switch indicates when DC power is applied to the inverter. Pressing the momentary button controls On/Off operation of the inverter.

Note: If an extension cord is used from the inverter to the appliance, limit the extension cord length to 50 feet or less. Make sure that the cord is properly rated to carry the appliance load.

CHARGING THE BATTERY BANK

It is not the purpose of this Inverter User's Guide to provide detailed information regarding battery charging systems. However, the user should try to augment any charging system with either wind power or solar power. These can continue to operate during power outages and they also reduce recharge time. If automatic AC powered battery chargers do not provide enough charging current for a larger battery bank, it is permissible to have two automatic battery chargers connected to the battery bank.

REGULAR LOSS OF COMMERCIAL POWER

If the inverter system is used during commercial power outages that occur daily, configure the charger system to replace energy during the time that commercial power is available. Replacement of battery energy always requires more than was taken from the battery (typically 130 percent). In the example used earlier in this document, the AC load ran for 10 hours. If commercial power is available, there are approximately 14 hours left in the day to do the recharging. The following is an example of what is necessary to recharge a battery bank that has 16500 AH of capacity (as in the example above) and has been discharged to 10.5 volts (discharged). The charger has to replace 2145 AH (1650x 1.3 AH) in 14 hours, so the charger must charge at a rate of 153 amps for 14 hours. As this charge current is distributed among the batteries in the battery bank, the current received by an individual battery is within its charge rating. Be sure that the battery is well vented as the area will likely have accumulations of an explosive mixture of hydrogen and oxygen. Follow all recommendations for use that are contained in the battery charger manual.

WARNING

THERE IS DANGER OF AN EXPLOSION. DO NOT CONNECT OR DISCONNECT CHARGER CABLES DIRECTLY AFTER BATTERY DISCHARGE OR RECHARGE — MAKE SURE THAT THE BATTERY BANK AREA IS WELL VENTED BEFORE ATTACHING OR REMOVING CABLES.

If flooded lead acid batteries are used, as examples given in this document, be sure that periodic checks of battery electrolyte levels are done. Follow battery manufacturer's instructions in keeping the electrolytes at the proper level. Be sure to use pure distilled water when replacing evaporated electrolyte liquid.

ABOARD A VESSEL OR VEHICLE.

Manufacturer supplied engine driven alternators can usually be replaced with one that can continuously deliver higher amperage. This should be done at the outset. Keep the batteries

charging when the vessel or vehicle engine is operating. In the case of a vessel, make sure that shore power is used to recharge the batteries whenever possible.

OPERATING ISSUES

Television and Audio Suggestions

Although all inverters are shielded and filtered to minimize signal interference, some interference with your television picture may be unavoidable, especially with weak signals. However, here are some suggestions that may improve reception.

- First, make sure that the television antenna produces a clear signal under normal operating conditions (i.e. at home plugged into a standard 110/120V AC wall outlet). Also ensure that the antenna cable is properly shielded and of good quality.
- Change the positions of the inverter, antenna cables and television power cord.
- Isolate the television, its power cord and antenna cables from the 12 volt power source by running an extension cord from the inverter to the television set.
- Coil the television power cord or install a clamp-on ferrite choke (available from electronic parts suppliers).

Note: Some inexpensive audio systems may have a slight “buzzing” sound when operated with the inverter. This is caused by insufficient filtering in the audio system. The only solution to this problem is to get a sound system with a higher quality power supply.

TROUBLESHOOTING

PROBLEM: Low or no output voltage

Reason	Solution
Poor contact with battery terminals.	Clean terminals thoroughly.
Using incorrect type of voltmeter to test output voltage.	Use true RMS reading meter.

PROBLEM: Inverter shutdown

Reason	Solution
Battery voltage below 10 volts. (Code E03)	Recharge or replace battery.
Equipment being operated draws too much power. (Codes E01 or E02 or E03)	Use a higher capacity inverter or do not use this equipment.

Reason	Solution
Inverter is too hot: thermal shutdown. (Code E02)	Allow inverter to cool. Check for adequate ventilation. Reduce the load on the inverter to rated continuous power output.
Unit may be defective.	See warranty and call customer service.

PROBLEM: TV interference

Reason	Solution
Electrical interference from the inverter.	Add a ferrite data line filter on to the TV power cord.

PROBLEM: Low battery alarm on all the time (Code E03)

Reason	Solution
Input voltage below 10.5 volts.	Keep input voltage above 10.5 volts to maintain regulation.
Poor or weak battery condition.	Recharge or replace battery.
Inadequate power being delivered to the inverter or excessive voltage drop.	Use lower gauge wire. Keep wire length as short as possible.

PROBLEM: TV does not work

Reason	Solution
TV does not turn on.	Contact TV manufacture to see if the TV is compatible with a modified sine wave.

3000 Watt AC Inverter by Wagan Tech

SPECIFICATIONS

Name	Description
Input	12V (10-15V) DC
Output	120V AC ± 10%
Frequency	60 Hz
Output Waveform	Modified Sine Waveform
Continuous Power	3000 watts
Surge Power	6000 watts
Efficiency	Approximately 90%
No load	
Switch ON	<3.0A DC
Switch OFF	<0.2mA DC
Low Battery Alarm	10.5 ± 0.5V DC
Low Battery Shutdown	10 ± 0.5V DC
Over Temp Shutdown	140°F ± 9°F (60°C ± 5°C)
AC output sockets	2 US standard
Power switch	DC input ON/OFF control
Dimensions (L x W x H)	12.8 x 7.2 x 6.8 inches (325 x 182 x 173 mm)
Net Weight	11.7 lbs (5.3 Kg) approximately

NOTE

All specifications are typical at nominal line, half load, and 77°F (25°C) unless otherwise noted. Specifications are subject to change without notice.

DISPOSAL OF INVERTER

Electronic products are known to contain materials that are toxic if improperly disposed. Contact local authorities for disposal and recycling information.



Please activate my limited warranty for WAGAN Corp.

Name	
Mailing address	
City	
State, Zip code	
E-mail address	
Item purchased	Item no.
Store name	
Date of purchase	Date
Signature	

All WAGAN Corporation Products must be registered within (30) days of purchase to activate this warranty. Mail the complete registration form, along with a copy of the original sales receipt to:

Attn: Customer Service
WAGAN Corporation
31088 San Clemente St.
Hayward, CA 94544

WAGAN Corp. Limited Warranty

All WAGAN Corporation products are warranted to the original purchaser of this product.

Warranty Duration: This product is warranted to the original purchaser for a period of two (2) Years from the original purchase date, to be free of defects in material and workmanship. WAGAN Corporation disclaims any liability for consequential damages. In no event will WAGAN Corporation be responsible for any amount of damages beyond the amount paid for the product at retail. In the event of a defective item, please contact WAGAN Corporation at (800) 231-5806 to obtain a Returned Merchandise Authorization number (RMA#), and return instructions. Each item returned will require a separate RMA#. After you have received the RMA# and the return instructions from WAGAN Corporation, please follow the instructions and send the item with PREPAID SHIPPING, along with all of the required documentation, a complete explanation of the problem, your name, address and daytime phone number. WAGAN Corporation will, at its option, replace or repair the defective part.

A Returned Merchandise Authorization number (RMA#) is REQUIRED when sending in any defective item. WAGAN Corporation is not responsible for any item(s) returned without an official Returned Merchandise Authorization number. The item(s) must be returned with prepaid shipping. WAGAN Corporation is not responsible for any shipping charges incurred in returning the item(s) back to the company for repair or replacement. This warranty is void if the product has been damaged by accident, in shipment, unreasonable use, misuse, neglect, improper service, commercial use, repairs by unauthorized personnel or other causes not arising out of defects in materials or workmanship. This warranty is effective only if the product is purchased and operated in the USA and does not extend to any units which have been used in violation of written instructions furnished.

Warranty Disclaimers: This warranty is in lieu of all warranties expressed or implied and no representative or person is authorized to assume any other liability in connection with the sale of our products. There shall be no claims for defects or failure of performance or product failure under any theory of tort, contract or commercial law including, but not limited to negligence, gross negligence, strict liability, breach of warranty and breach of contract.

Warranty Performance: During the above two (2) Year warranty period, a product with a defect will be replaced with a comparable model when the product is returned to WAGAN Corporation with an original store receipt. The replacement product will be in warranty for the balance of the two (2) Year warranty period. *Updated July 2009*



www.wagan.com
customerservice@wagan.com
Toll Free: 1.800.231.5806

31088 San Clemente St.
Hayward, CA. 94544
U.S.A.