

# Enphase Energy System planning with IQ Battery 10C/10CS and IQ Combiner 6C

**Applicable regions: North America**

© 2026 Enphase Energy. All rights reserved. Enphase, the e and CC logos, IQ, and certain other marks listed at <https://enphase.com/trademark-usage-guidelines> are trademarks of Enphase Energy, Inc. in the U.S. and other countries. Data subject to change.

# Contents

<b>1</b>	<b>About this guide.....</b>	<b>5</b>
<b>2</b>	<b>Enphase Energy System overview.....</b>	<b>5</b>
2.1	Product overview.....	6
2.2	Interoperability with other product generations.....	7
<b>3</b>	<b>Design an Enphase Energy System.....</b>	<b>7</b>
3.1	National Electrical Code.....	7
3.2	Power Control Systems (PCS).....	8
<b>4</b>	<b>Economic use cases.....</b>	<b>9</b>
<b>5</b>	<b>System profiles.....</b>	<b>10</b>
<b>6</b>	<b>System sizing.....</b>	<b>10</b>
6.1	Grid-tied systems.....	10
6.2	Grid-forming systems.....	10
6.2.1	Load analysis.....	11
6.2.2	Storage system sizing.....	11
6.2.3	IQ EV Charger integration.....	15
<b>7</b>	<b>Component list.....</b>	<b>16</b>
<b>8</b>	<b>Grid-tied (without backup) system configurations.....</b>	<b>18</b>
8.1	Grid-tied solar system.....	18
8.2	Grid-tied solar and battery system.....	19
8.3	Grid-tied battery-only system.....	20
<b>9</b>	<b>Grid-forming (with backup) system configurations.....</b>	<b>20</b>
9.1	Grid-forming solar and battery system.....	21
9.2	Grid-forming solar and battery system with IQ Meter Collar under the utility meter.....	22
9.3	Grid-forming battery-only system.....	23
<b>10</b>	<b>Backup-ready system.....</b>	<b>23</b>
<b>11</b>	<b>System variations based on IQ Meter Collar approval.....</b>	<b>24</b>
11.1	IQ Meter Collar approved by the utility.....	24
11.1.1	IQ Meter Collar installed in the main-meter combo panel.....	24

- 11.1.2 IQ Meter Collar installed in Form 2S meter panel..... 25
- 11.2 IQ Meter Collar not approved by utility.....25**
  - 11.2.1 Load-side meter socket..... 25
  - 11.2.2 Supply-side meter socket..... 26
- 12 Supported partial home backup configurations.....26**
  - 12.1 400 A supply configuration #1..... 27
  - 12.2 400 A supply configuration #2..... 28
  - 12.3 200 A supply configuration..... 29
- 13 Legacy and third-party PV support..... 30**
  - 13.1 Grid-forming legacy and third-party PV support/NEM expansion..... 30
  - 13.2 Grid-tied NEM expansion configuration..... 31
  - 13.3 Grid-tied non-NEM expansion configuration..... 32
- 14 Supply-side connection..... 33**
- 15 External shutdown initiators and disconnect options..... 33**
  - 15.1 Grid-side disconnect (on the backfeed to the backup panel)..... 34
  - 15.2 PV disconnect in line with the PV aggregate breaker..... 35
  - 15.3 PV disconnect in line with the external combiner (2-pole)..... 35
  - 15.4 PV disconnect in line with the external combiner (3-pole)..... 36
- 16 System shutdown behavior.....37**
  - 16.1 Grid-tied (non-backup) system shutdown behavior..... 38**
    - 16.1.1 Normal behavior..... 38
    - 16.1.2 Initiators in the grid-tied system..... 38
    - 16.1.3 Shutdown mechanism..... 39
    - 16.1.4 Grid-tied system behavior..... 39
  - 16.2 Grid-forming (backup) system shutdown behavior..... 41**
    - 16.2.1 Normal behavior..... 41
    - 16.2.2 Initiators in the grid-forming system..... 41
    - 16.2.3 Shutdown mechanism..... 42
    - 16.2.4 Grid-forming system behavior..... 43
- 17 Appendix A: Abbreviations..... 45**
- 18 Appendix B: Legend.....46**

19	Appendix C: Planned configurations (not supported at launch).....	48
20	Revision history.....	51

## 1. About this guide

This document contains information for site surveyors and design engineers to analyze a site and plan the design, installation, and support of home energy backup systems using the 4th-generation Enphase Energy System consisting of IQ Battery 10C/10CS, IQ Combiner 6C, IQ Meter Collar, and IQ Microinverters. This is not a guide for installation and operation. This document supplements the information in the data sheets, quick install guides, and product manuals. The diagrams and information in this document illustrate system configurations and installations. They may not, however, include all state and local codes, standards, and other requirements from Authorities Having Jurisdiction (AHJs) applicable to a site.



**NOTE:** Unless otherwise noted, "Enphase Energy System" refers to its 4th generation throughout this document.

### Related documents

- [IQ Battery 10C quick install guide](#)
- [IQ Combiner 6C quick install guide](#)
- [IQ Meter Collar quick install guide](#)
- [Compatibility matrix](#)
- [PCS integration in 4th-generation Enphase Energy Systems](#)
- [Enphase Energy System with IQ Battery 10C Owner's guide](#)
- [Concept of operations: 4th-generation Enphase Energy System with IQ Meter Collar](#)

## 2. Enphase Energy System overview

An Enphase Energy System falls into one of the following groups depending on the energy sources used.

- Solar Only
- Battery Only
- Solar Plus Battery

The system can also be divided into grid-tied and grid-forming systems based on its ability to form a microgrid. A grid-forming system must have an IQ Meter Collar and IQ Battery 10C/10CS installed.

Grid-forming systems can be categorized as whole home or partial home backup systems.

**Whole home backup:** When the power grid fails, the Enphase Energy System switches all electrical circuits to backup power. The system must have sufficient backup power and energy capacity to support all the loads in a home.

**Partial home backup (planned configuration, currently not supported):** The home loads are segregated into backup and non-backup loads. A backup load panel is set up to power backup loads. During a grid outage, the Enphase Energy System powers the backup load panel while leaving the main load panel unpowered.



**NOTE:** Whole-home backup with load control, using the integrated load controller in the IQ Combiner 6C, is now supported.

## 2.1 Product overview

**IQ8 Series Microinverters and accessories:** The Enphase Energy System is fully compatible with IQ8 Series Microinverters.

**IQ6/IQ7 Series Microinverters and accessories:** The Enphase Energy System is fully compatible with IQ7 and IQ6 Series Microinverters. Retrofit upgrades are as simple as new installations.



**WARNING:**

- IQ8 Series Microinverters are not backward compatible with IQ6 or M Series Microinverters.
- Enphase Energy System does not support mixing IQ6 Series Microinverters with IQ8 Series Microinverters or M Series Microinverters.



**IMPORTANT:** IQ8 Series Microinverters can be added to existing IQ7 systems using the same IQ Gateway in the following grid-tied configurations only:

- Solar Only
- Solar + Battery without backup



**IMPORTANT:**

- IQ7 Series Microinverters cannot be added to a site with existing IQ8 Series Microinverters using the same gateway.
- A mixed system of IQ7 and IQ8 Series Microinverters will not support IQ8-specific PCS features and grid-forming capabilities.
- If IQ7 Microinverters need to be added to a site using the same gateway where IQ8 Microinverters are present, the IQ8 Microinverters must be retired and recommissioned after commissioning the IQ7 Microinverters.



**IMPORTANT:** M Series Microinverters or other legacy microinverters are incompatible with IQ Combiner 6C.

The **IQ Battery 10C/10CS** all-in-one AC-coupled system is compact, powerful, reliable, and safe. It has a total usable capacity of 10.0 kWh. Each IQ Battery 10C/10CS includes four grid-forming microinverters with a 7.08 kVA continuous power rating. When installed with an IQ Meter Collar, the IQ Battery 10C/10CS can provide backup capability, and installers can design the right system size to meet the customer's needs. Each system can support up to eight IQ Battery 10C/10CS, providing up to 30.72 kW of power and 80 kWh of energy storage.

The IQ Battery 10C and IQ Battery 10CS are two variants of the same battery. The only difference lies in the **type of cover** that comes with each.

- **IQ Battery 10C:** Includes a cover that supports **dual stacking** of the 5 kWh battery modules.
- **IQ Battery 10CS:** Includes a cover designed for **vertical or horizontal stacking** of the 5 kWh battery modules.



**NOTE:** The **IQ Battery 10CS** will be **available in the future**.

**IQ Combiner 6C** is an all-in-one solution that integrates breaker spaces for PV (3 × 20 A + 1 × 20-20 A quad breaker), battery (2 × 80 A), and EV charger (1 × 60 A). It includes factory-installed current transformers (CTs) for monitoring PV and battery current. It also has an option to add CT for the IQ EV Charger. The IQ Combiner 6C is rated for an output of 100 A continuous current to the main panel (125 A breaker). The Combiner 6C is designed for field serviceability, allowing field replacement of the IQ Gateway and combiner controller boards. An integrated load controller supports load and

PV circuit monitoring and control. It helps avoid upsizing the system cost if NEC 2023 702.4 (A) or 710.15 (A) requires a larger system size. The integrated load controller supports up to 1 × 80 A BR form factor, double-pole breaker, or quad breakers with max. 80 A per phase. The load controller includes integrated hold-down functionality for the breaker and comes equipped with current transformers (CTs) for monitoring load consumption.

Ride-through power supply board (RT-PSB) is an optional accessory. The IQ Combiner 6C is fully IEEE 2030.5 compliant for solar-only or solar + storage or storage-only systems without the ride-through power supply board.



**NOTE:** IQ Gateway and Mobile Connect cellular modem are integrated into the IQ Combiner 6C.



**NOTE:** Stand-alone IQ Gateway integration is not supported with IQ Battery 10C/10CS.

## 2.2 Interoperability with other product generations

- IQ Battery 10C/10CS works only with IQ Combiner 6C. It does not work with IQ Gateway or Envoy S Metered.
- IQ Battery 10C/10CS and IQ Combiner 6C do not work with any variants of the IQ System Controller.
- IQ Battery 10C/10CS and IQ Combiner 6C are not compatible with IQ Battery 3T, IQ Battery 10T, IQ Battery 5P, or with earlier IQ Combiners. Compatibility with IQ Battery 5P will be available in the future.
- IQ Combiner 6C supports direct integration of IQ Series Microinverters.
- IQ Combiner 6C does not support legacy Enphase microinverters or third-party inverters at the time of product launch. These will be supported in the future.

## 3. Design an Enphase Energy System

To learn about designing an Enphase Energy System, see the following topics.

### 3.1 National Electrical Code

The National Electrical Code Article 705 Part II allows a microgrid system to disconnect from the utility grid and operate in island mode, forming an intentional island, or in other words, a microgrid that supplies backup power. The ability of an inverter to transition between interactive and island modes is called multi-mode operation. A system capable of islanding requires a microgrid interconnect device (MID) to island the home from the utility grid.

The MID in IQ Meter Collar allows the IQ Battery 10C/10CS to establish an intentional island or operate in island mode when disconnected from the area's electric power.

The following figure shows a drawing of an AC-coupled multi-mode system based on 2020 NEC sections 690 and 705. For more information, see [External shutdown initiators and disconnect options](#) on page 33.

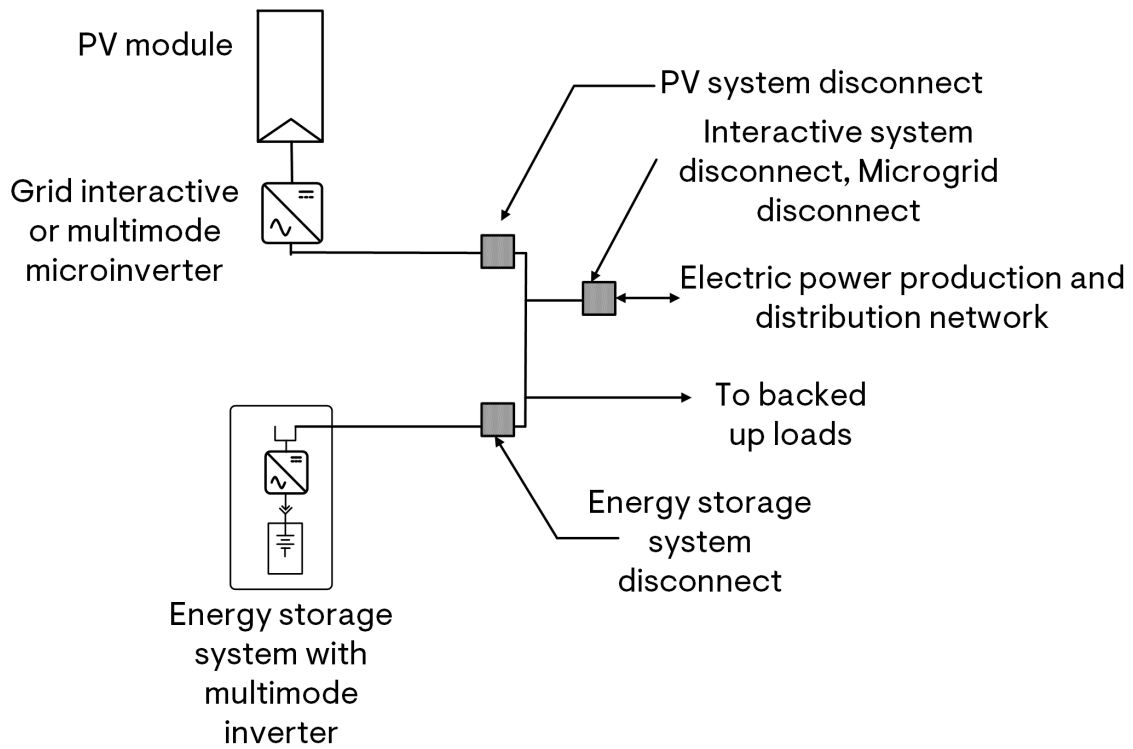

Figure 1: AC-coupled multi-mode system

### 3.2 Power Control Systems (PCS)

Power Control Systems (PCS), as defined in NFPA 70, NEC 2020 705.13, control the output of one or more power production sources, energy storage systems (EES), and other equipment. PCS limits the current flowing in the busbars and conductors supplied by the power production sources and/or energy storage systems.

Enphase Energy Systems have electric power production sources such as microinverters and/or IQ Batteries interconnected in parallel. The number of power production sources that can be connected to a system is generally governed by various sections of the NEC. PCS allows you to install more batteries in the Enphase Energy System. It also provides features to adhere to special compliance requirements in certain jurisdictions.

PCS enables the following features in the Enphase Energy System:

- IQ Battery oversubscription mode: It increases the energy storage capacity that can be installed for a given battery breaker rating by reducing the maximum continuous current rating of the battery to comply with 2020 NEC 705.28. Battery oversubscription can increase the energy capacity of the battery array by up to 200%; that is, up to four IQ Battery 10C/10CS units can be connected to an 80 A breaker on IQ Combiner 6C.

The overload capacity of an IQ Battery 10C/10CS remains the same, regardless of whether battery oversubscription is enabled. Battery oversubscription increases overload capacity relative to the new continuous current rating and is coordinated with circuit breaker trip curves.

Table 1: Overload current rating of one IQ Battery 10C/10CS

Overload current (Amperes)	Time (seconds)
56 A	3
44.8 A	5

- Battery import-only mode<sup>1</sup>: This feature ensures that the IQ Battery never exports power to the grid but can import from the grid.
- Battery export-only mode: The battery export-only feature ensures that the IQ Battery never imports any power from the grid but can export to the grid.

 **NOTE:** IQ Battery can operate either in battery import-only mode or battery export-only mode.

- Main panel upgrade (MPU) avoidance
  - The MPU avoidance feature can be configured using the following three options:
    - Using Busbar Overload Control
    - With Feeder Control (using the NEC 120% rule)
    - With Feeder Control (using the Current Limit Directly Entered)
  - MPU avoidance with Busbar Overload Control: Allows maximum renewable energy generation and helps avoid the cost of panel upgrade for large PV and battery systems under National Electrical Code (NEC) 2020 705.13, reducing the system payback period. This is supported only if the system has IQ8 Series Microinverters.
  - MPU avoidance with Feeder Control: Enables avoiding the cost of a panel upgrade for large PV and battery systems by controlling the backfeed current into the main panel according to the National Electrical Code (NEC) 2020 705.12. The feature ensures that the backfeed current allowed into the main panel is limited as per the configuration provided by the installer for both grid-tied and grid-forming configurations.
- Aggregate power export limit (PEL) mode<sup>1</sup>: This PCS feature ensures that the aggregate PV power exported to the grid is limited to the aggregate power export limit (PEL) value set by the installer. This limits the aggregate power export below the defined level, as measured at the Consumption CTs.
 

 **NOTE:** Only IQ8 Series Microinverters support the Aggregate power export limit mode and MPU avoidance with Busbar Overload Control.
- NEM integrity mode<sup>1</sup>: This is a PCS mode in which the PV and energy storage system (ESS) are evaluated for their ability to limit the export levels of a PCS-controlled PV/ESS system to the grid, when operated in the presence of an uncontrolled PV/ESS legacy system. In this mode, the PCS-controlled PV and ESS's output power is controlled such that the instantaneous power exported by the combined system does not exceed the power generated by the legacy system.

For more information, see [PCS integration in 4th-generation Enphase Energy Systems](#).

## 4. Economic use cases

The Enphase Energy System supports many economic goals. These include reducing utility bills by charging the batteries during low-tariff periods and saving energy to ensure that loads can be served

<sup>1</sup> Not available at launch

through the batteries during high-tariff periods. Power from PV can be exported to the grid, especially during peak tariff periods.

Optimizing energy storage capacity and system sizing for economic use cases is beyond the scope of this document.

## 5. System profiles

The Enphase Energy System supports three smart battery profiles: Full Backup, Self-Consumption, and AI Optimization/Savings Mode.

- Full Backup: 100% of the battery capacity is reserved for backup, and the battery does not discharge while the system is connected to the grid. This profile is not available in grid-tied configurations.
- Self-Consumption: To ensure the home loads are served with PV and storage to the extent possible, the battery discharges until its reserved capacity. Effectively, the system minimizes grid imports. The battery discharges until the reserve charge limit is reached while on the grid and below the reserve charge limit when the grid is down. This profile is not available in battery-only systems.
- AI Optimization/Savings Mode: This profile is for the economic use case wherein the battery discharges at peak tariffs and charges using PV during low tariff periods.

✓ **NOTE:** AI optimization is available only in a restricted number of states today. These states usually have export/import rates that vary by time, month, or on a dynamic day-to-day basis.

✓ **NOTE:** The battery discharges up to the reserve charge limit while on the grid and below the reserve charge limit when the grid is down.

A description of these modes with screenshots of how homeowners can select the same is available in the [Enphase Energy System with IQ Battery 10C Owner's guide](#).

✓ **NOTE:** In all modes, the battery charges from the grid until the reserve charge limit to ensure that the desired amount of battery charge for backup is guaranteed to be available.

## 6. System sizing

### 6.1 Grid-tied systems

For grid-tied systems, optimal system sizing is a financial decision driven by factors such as solar irradiance at the location, energy usage patterns, and energy tariffs. Enphase recommends using the Solargraf tool to model and size the system appropriately.

### 6.2 Grid-forming systems

For grid-forming systems, additional analysis is required to align system capabilities with customer expectations, particularly regarding backup duration, the ability to support high-demand appliances like HVAC systems, and overall system resilience.

### 6.2.1 Load analysis

A proper load analysis is the first step in effectively sizing a system. If an IQ Gateway with properly configured Consumption CTs is already installed at a site, Enphase Cloud data can be used to size the system properly. Load data for system size can also be obtained through a site survey, utility bills, and third-party consumption meters.

### 6.2.2 Storage system sizing

1. Identify the largest single load power rating (kW) you want to back up and select the minimum IQ Battery 10C/10CS units required to meet the 2020 NEC 710.15(A) requirements.
2. Based on the estimated backup loads for the user-defined period, calculate the required energy storage (kWh) capacity and the minimum IQ Battery 10C/10CS units needed.
3. Based on a site's load analysis of both power (kW) and energy capacity (kWh) needed, determine the total number of IQ Battery 10C/10CS units required for the storage system.
4. The minimum IQ Battery 10C/10CS units required is calculated as the largest of steps 1 and 2.
5. The desired number of IQ Battery 10C/10CS units is the value calculated in step 3.

 **NOTE:** The integrated load controller in IQ Combiner 6C can control the backup load circuits that exceed the storage power capacity.

The PV busbar supports up to five PV branch circuit breakers, while the DER busbar includes two battery breaker positions—one for the EV charger and the other for the load controller. Refer to the following system sizing guidelines to ensure compatibility when combining IQ Battery 10C, IQ Series Microinverters, and legacy or third-party PV in a single system.

#### 6.2.2.1 Systems with IQ6/IQ7 Series Microinverters

When Enphase IQ6 or IQ7 Microinverters are connected to the PV busbar, the maximum allowable PV system size is limited to 150% of the rated kVA of the battery system.

 **NOTE:** This sizing constraint applies only when no third-party PV system is connected to the load controller.

Table 2: PV-to-battery ratio for IQ6/IQ7 Series Microinverters only systems

Number of IQ Battery 10C	Battery rated kWh	Battery rated kVA	Max. IQ6/IQ7 Series PV kVA
1	10	7.08	10.62
2	20	14.16	19.2
3	30	21.24	19.2
4	40	28.32	19.2
5 <sup>2</sup>	50	30.72	19.2
6 <sup>2</sup>	60	30.72	19.2
7 <sup>2</sup>	70	30.72	19.2
8 <sup>2</sup>	80	30.72	19.2

<sup>2</sup> With IQ Battery oversubscription.

### 6.2.2.2 Systems with IQ8 Series Microinverters

When IQ8 Series Microinverters are connected to the PV busbar, the maximum allowable PV system size is 270% of the rated kVA of the battery system. This sizing ratio enables support for up to five fully populated PV branch circuits on the PV busbar when paired with a single IQ Battery 10C.

 **NOTE:** This sizing constraint is valid only when no third-party PV system is connected to the load controller

Table 3: PV-to-battery ratio for IQ8 Series Microinverters-only systems

Number of IQ Battery 10C	Battery rated kWh	Battery rated kVA	Max. IQ8 Series PV kVA
1	10	7.08	19.2
2	20	14.16	19.2
3	30	21.24	19.2
4	40	28.32	19.2
5 <sup>3</sup>	50	30.72	19.2
6 <sup>3</sup>	60	30.72	19.2
7 <sup>3</sup>	70	30.72	19.2
8 <sup>3</sup>	80	30.72	19.2

### 6.2.2.3 Systems with legacy Enphase PV or third-party PV

The integrated load controller in the IQ Combiner 6C can be used to support third-party or legacy PV systems that do not communicate directly with the IQ Gateway. These systems are treated as third-party PV by the Enphase Energy System. This includes:

- Non-Enphase PV systems.
- Enphase PV systems that are controlled by a separate IQ Gateway and are connected to the IQ Combiner 6C via a PLC filter.

#### 6.2.2.3.1 Third-party PV behavior in Off-Grid mode

**Current behavior:** In systems operating off-grid, any third-party PV connected to the load controller is currently shed and does not contribute to load support or battery charging.

**Future capability:** If the system is designed in accordance with the specified PV-to-battery sizing ratios, a future software update will enable third-party PV to remain active during off-grid operation, allowing it to charge batteries and supply loads.

#### 6.2.2.3.2 Systems with third-party PV only

Maximum third-party PV/legacy PV allowed to be connected to the integrated load controller is 100% × Rated kVA of the battery array. Third-party PV is limited to 15.36 kVA based on the maximum ampacity supported by the integrated load controller.

<sup>3</sup> With IQ Battery oversubscription.

 **NOTE:** Third-party or legacy Enphase PV systems connected to the integrated load controller act as uncontrolled power sources on the load side. Their maximum size must follow these rules:

1. Breaker sizing: The breaker feeding the IQ Combiner 6C in the backup panel must be equal to or larger than the integrated load controller breaker. This prevents the breaker from tripping due to backfeed by the uncontrolled source.
2. NEC 2023 705.15(B) – 120% rule: The combined ratings of the main breaker (primary source) feeding the backup panel and the integrated load controller breaker in the IQ Combiner 6C (additional source) must not exceed 120% of the busbar rating when backfed. Review NEC 705.15(B) for requirements on breaker placement and so on.

To ensure accurate system sizing and avoid calculation errors, refer to the following table when determining the maximum supported capacity (in kVA) of third-party or legacy Enphase PV capacity that can be supported by the system.

Table 4: PV-to-battery ratio for third-party PV/legacy PV-only systems

Number of IQ Battery 10C	Battery rated kWh	Battery rated kVA	Max. third-party/ legacy PV kVA
1	10	7.08	7.08
2	20	14.16	14.16
3	30	21.24	15.36
4	40	28.32	15.36
5 <sup>4</sup>	50	30.72	15.36
6 <sup>4</sup>	60	30.72	15.36
7 <sup>4</sup>	70	30.72	15.36
8 <sup>4</sup>	80	30.72	15.36

**6.2.2.3.3 Systems with IQ6/IQ7 Series Microinverters and third-party/legacy PV**

In systems where third-party PV is connected to the load controller and IQ6/IQ7 Series Microinverters are connected to the PV busbar, the combined PV system size (i.e., third-party PV + Enphase PV) must not exceed 150% of the rated kVA of the battery system. Additionally, the third-party PV system alone must not exceed 100% of the battery system’s rated kVA.

 **NOTE:** Third-party or legacy Enphase PV systems connected to the integrated load controller act as uncontrolled power sources on the load side. Their maximum size must follow these rules:

1. Breaker sizing: The breaker feeding the IQ Combiner 6C in the backup panel must be equal to or larger than the Integrated Load Controller breaker. This prevents the breaker from tripping due to backfeed by the uncontrolled source.
2. NEC 2023 705.15(B) – 120% rule: The combined ratings of the main breaker (primary source) feeding the backup panel and the Integrated Load Controller breaker in the IQ Combiner 6C (additional source) must not exceed 120% of the busbar rating when backfed. Review NEC 705.15(B) for requirements on breaker placement and so on.

<sup>4</sup> With IQ Battery oversubscription.

To ensure accurate system sizing and avoid calculation errors, refer to the following table when determining the maximum supported capacity (in kVA) of IQ6/IQ7 Series Microinverters and third-party or legacy Enphase PV capacity that can be supported by the system.

Table 5: PV-to-battery ratio for IQ6/IQ7 Series Microinverter + third-party/legacy PV system

Number of IQ Battery 10C	Battery rated kWh	Battery rated kVA	Max. IQ6/IQ7 Series PV kVA	Max. third-party/legacy PV kVA	Max. combined PV (IQ6/IQ7 + third party) kVA
1	10	7.08	10.62	7.08	10.62
2	20	14.16	19.2	14.16	21.24
3	30	21.24	19.2	15.36	31.86
4	40	28.32	19.2	15.36	34.56
5 <sup>5</sup>	50	30.72	19.2	15.36	34.56
6 <sup>2</sup>	60	30.72	19.2	15.36	34.56
7 <sup>2</sup>	70	30.72	19.2	15.36	34.56
8 <sup>2</sup>	80	30.72	19.2	15.36	34.56

**6.2.2.3.4 Systems with IQ8 Series Microinverters and third-party/legacy PV**

In systems where third-party PV is connected to the load controller and IQ8 Series Microinverters is connected to the PV busbar, the combined PV system size (i.e., third-party PV + Enphase PV) must not exceed 270% of the rated kVA of the battery system. Additionally, the third-party PV system alone must not exceed 100% of the battery system’s rated kVA.



**NOTE:** Third-party or legacy Enphase PV systems connected to the integrated load controller act as uncontrolled power sources on the load side. Their maximum size must follow these rules:

1. Breaker sizing: The breaker feeding the IQ Combiner 6C in the backup panel must be equal to or larger than the integrated load controller breaker. This prevents the breaker from tripping due to backfeed by the uncontrolled source.
2. NEC 2023 705.15(B) – 120% rule: The combined ratings of the main breaker (primary source) feeding the backup panel and the integrated load controller breaker in the IQ Combiner 6C (additional source) must not exceed 120% of the busbar rating when backfed. Review NEC 705.15(B) for requirements on breaker placement and so on.

To ensure accurate system sizing and avoid calculation errors, refer to the following table when determining the maximum supported capacity (in kVA) of IQ8 Series Microinverters and third-party or legacy Enphase PV capacity that can be supported by the system.

<sup>5</sup> With IQ Battery oversubscription.

Table 6: PV-to-battery ratio for IQ8 Series Microinverter + third-party/legacy PV system

Number of IQ Battery 10C	Battery rated kWh	Battery rated kVA	Max. IQ8 Series PV kVA	Max. third-party/legacy PV kVA	Max. combined PV (IQ8 + third-party) kVA
1	10	7.08	19.2	7.08	19.2
2	20	14.16	19.2	14.16	33.36
3	30	21.24	19.2	15.36	34.56
4	40	28.32	19.2	15.36	34.56
5 <sup>6</sup>	50	30.72	19.2	15.36	34.56
6 <sup>6</sup>	60	30.72	19.2	15.36	34.56
7 <sup>6</sup>	70	30.72	19.2	15.36	34.56
8 <sup>6</sup>	80	30.72	19.2	15.36	34.56

### 6.2.3 IQ EV Charger integration

The IQ Combiner 6C supports integration of the IQ EV Charger under the following conditions:

#### Breaker sizing requirements

- IQ EV Chargers with breaker size  $\leq 60$  A.  
These can be directly connected to the dedicated IQ EV Charger breaker slot in the IQ Combiner 6C.
- IQ EV Chargers with breaker size  $>60$  A and  $\leq 80$  A.  
These must be connected via the integrated load controller.

#### Grid-forming system constraints

- In grid-forming systems, the continuous current rating of the IQ EV Charger must not exceed the continuous power rating of the IQ Battery 10C units installed in the system.
  - ✓ **NOTE:** This ensures that the battery system can reliably support the EV charger load during off-grid or backup operation.
  - ✓ **NOTE:** Because IQ EV Chargers are rated at 32 A or higher, the system must include at least two IQ Battery 10C units to support installation on the EV-charger breaker position.

<sup>6</sup> With IQ Battery oversubscription.

## 7. Component list

For information about system sizing constraints, see [System sizing](#) on page 10.

Table 7: Component list for Solar Only, Battery Only, and Solar Plus Battery system configurations

Component type	Product name and model number	Grid-tied			Grid-forming	
		Solar Only	Battery Only	Solar Plus Battery	Battery Only	Solar Plus Battery
Microinverters	IQ8 Series <ul style="list-style-type: none"> <li>IQ8-60-2-US</li> <li>IQ8PLUS-72-2-US</li> <li>IQ8M-72-2-US</li> <li>IQ8A-72-2-US</li> <li>IQ8H-240-72-2-US</li> <li>IQ8MC-72-M-US</li> <li>IQ8AC-72-M-US</li> <li>IQ8HC-72-M-US</li> </ul>	Up to 80 A continuous	—	Up to 80 A continuous	—	Up to 80 A continuous
	IQ8 Series <ul style="list-style-type: none"> <li>IQ8H-208-72-2-US</li> </ul>	Up to 80 A continuous	—	Up to 80 A continuous	—	Up to 80 A continuous
	IQ7 Series <ul style="list-style-type: none"> <li>IQ7-60-2-US</li> <li>IQ7PLUS-72-2-US</li> <li>IQ7X-96-2-US</li> <li>IQ7A-72-2-US</li> </ul>	Up to 80 A continuous	—	Up to 80 A continuous	—	Up to 80 A continuous
	IQ6 Series <ul style="list-style-type: none"> <li>IQ6-60-2-US</li> <li>IQ6PLUS-72-2-US</li> </ul>	Up to 80 A continuous	—	Up to 80 A continuous	—	Up to 80 A continuous
Third-party PV/ Legacy Enphase PV <sup>7</sup>		Up to 64 A continuous	—	Up to 64 A continuous	Up to 64 A continuous	Up to 64 A continuous
Battery	IQ Battery 10C	—	Up to 8 units	Up to 8 units	Up to 8 units	Up to 8 units
	IQ Battery 10C Lifting Handle <ul style="list-style-type: none"> <li>B05CLH-0180-O</li> </ul>	—	1	1	1	1

<sup>7</sup> Shed while off-grid.

Component type	Product name and model number	Grid-tied			Grid-forming	
		Solar Only	Battery Only	Solar Plus Battery	Battery Only	Solar Plus Battery
AC combiner	IQ Combiner 6C • X-IQ-AM1-240-6C	1	1	1	1	1
	Ride-through power supply X-IQ-NA-PSBECAP-R6	Not required <sup>8</sup>	–	–	–	–
	Breakers Eaton BR2xx (20/30/40/60/80/100 A) GE/ABB THQL21xx (20/40/60/80/100 A) Siemens Q2xx (20/40/60/80/100A) Eaton BQC220220(20/20A), BQC220240 (20/40A)	As required	As required	As required	As required	As required
IQ Meter Collar	MC-200-011-V01	–	–	–	1	1
	Form 2S Meter pan	–	–	–	Needed for: <ul style="list-style-type: none"> <li>• Utilities that do not approve the IQ Meter Collar being installed behind the utility meter.</li> <li>• Supplies larger than 200 A.</li> <li>• Partial home backup.</li> </ul>	
EV charger	IQ EV Charger	0 or 1, up to 15.36 kW	0 or 1, up to 15.36 kW	0 or 1, up to 15.36 kW	0 or 1, up to 15.36 kW	0 or 1, up to 15.36 kW
Current transformers	EVSE CT: CT-200-SPLIT or CT-200-CLAMP	0 or 1	0 or 1	0 or 1	0 or 1	0 or 1
	Consumption CT: CT-200-SPLIT CT-200-CLAMP	2	2	2	0 or 2 <sup>9</sup>	0 or 2 <sup>9</sup>

<sup>8</sup> The IQ Combiner 6C is fully IEEE 2030.5 compliant for solar-only or solar + storage or storage-only systems without the ride-through power supply board.

<sup>9</sup> Required for a partial home backup system.

Component type	Product name and model number	Grid-tied			Grid-forming	
		Solar Only	Battery Only	Solar Plus Battery	Battery Only	Solar Plus Battery
	Third-party PV CT for NEM expansion: CT-200-SPLIT or CT-200-CLAMP	2	2	2	0 or 2 <sup>9</sup>	0 or 2 <sup>9</sup>
Control cable	CTRL-SC3-NA-01	—	As needed	As needed	As needed	As needed

## 8. Grid-tied (without backup) system configurations

Grid-connected systems can generate energy, supply it to home loads, and store it for later use if a battery is present—but only when the grid is available.

### 8.1 Grid-tied solar system

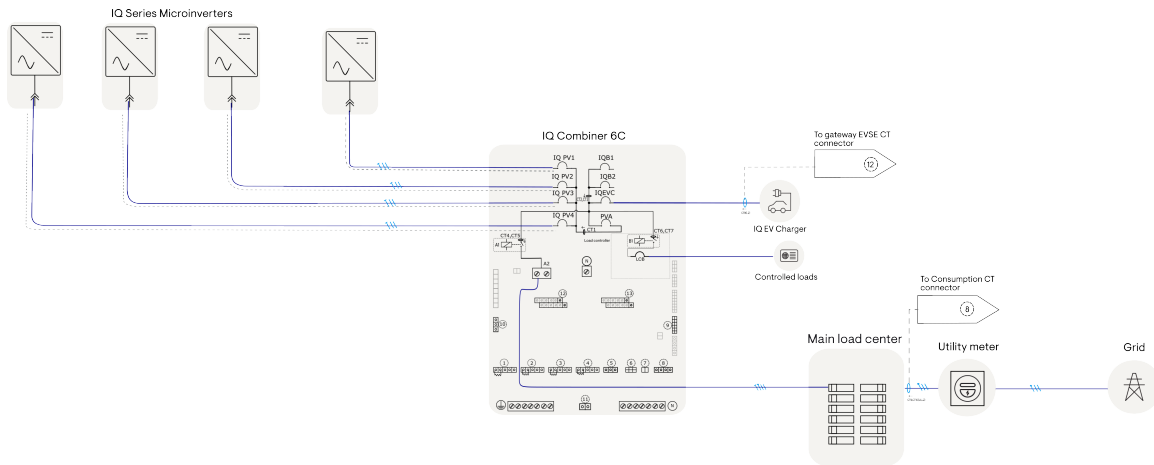

Figure 2: Solar grid-tied configuration with IQ8/IQ7/IQ6 Series Microinverters and IQ Combiner 6C

For notations, see [Legend](#) on page 46.

**NOTE:** The IQ Combiner 6C is fully IEEE 2030.5 compliant for Solar Only or Solar Plus Battery or Battery Only systems without the ride-through power supply board.

- External Consumption CTs (L1, L2) must be installed for home energy monitoring.
- A 5<sup>th</sup> PV branch circuit can be accommodated by using a quad breaker in the IQ PV4 breaker slot.

See [Power Control Systems \(PCS\)](#) on page 8 for details on supported PCS configurations.

## 8.2 Grid-tied solar and battery system

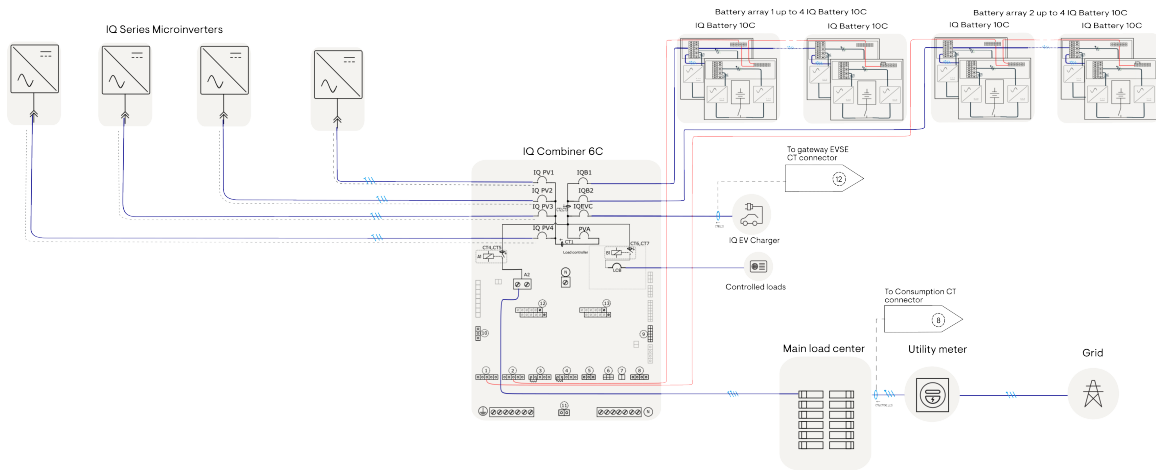

Figure 3: Solar and battery grid-tied configuration with IQ8 or IQ7/IQ6 Series Microinverters and IQ Combiner 6C

For notations, see [Legend](#) on page 46.

- External Consumption CTs (L1, L2) must be installed for home energy monitoring.
- A 5<sup>th</sup> PV branch circuit can be accommodated by using a quad breaker in the IQ PV4 breaker slot.

See [Power Control Systems \(PCS\)](#) on page 8 for details on supported PCS configurations.

### 8.3 Grid-tied battery-only system

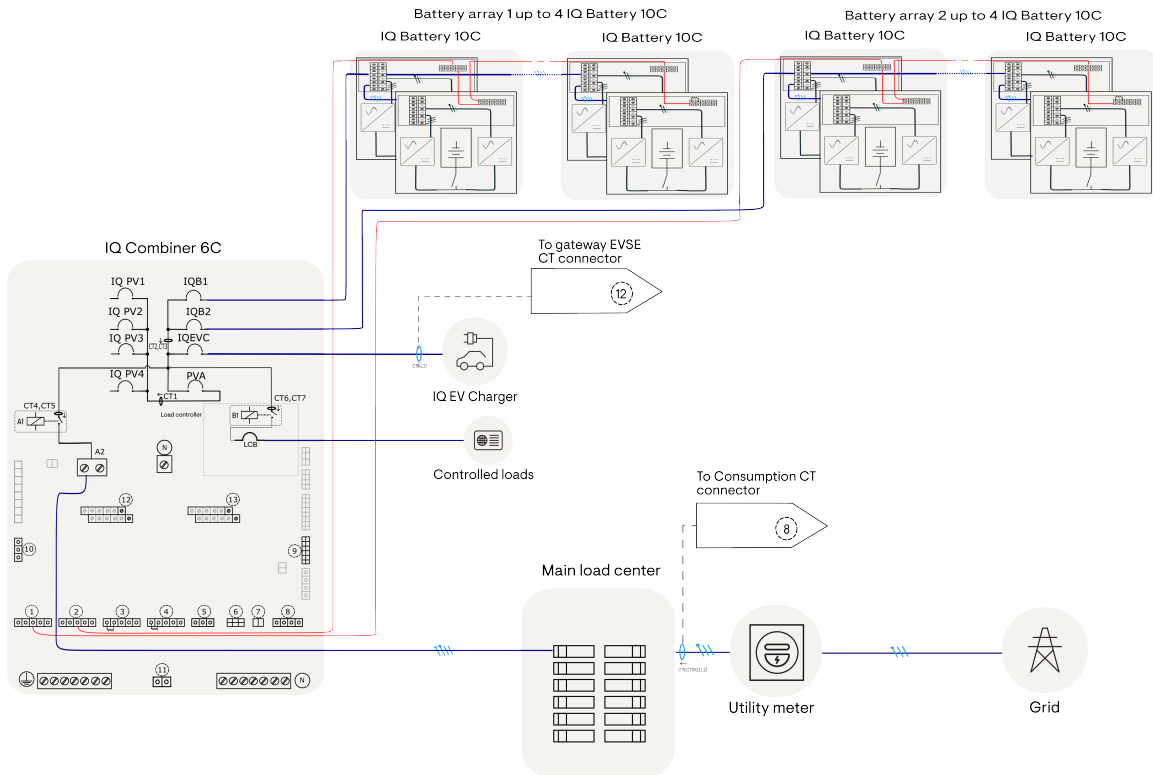

Figure 4: Grid-tied battery-only configuration

For notations, see [Legend](#) on page 46.

- An external Consumption CT must be installed for home energy monitoring.
- A charge from grid schedule must be set in the Enphase App for Battery Only systems.

See [Power Control Systems \(PCS\)](#) on page 8 for details on supported PCS configurations.

## 9. Grid-forming (with backup) system configurations

Grid-forming systems can generate energy, supply it to home loads, and store it in a battery for later use, even when the grid is unavailable.

## 9.1 Grid-forming solar and battery system

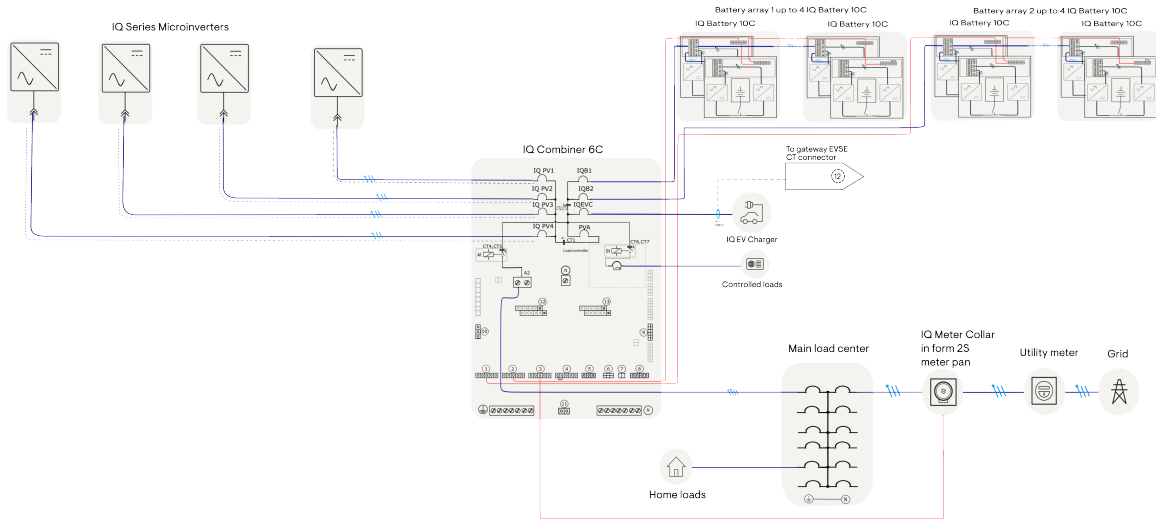

Figure 5: Grid-forming IQ8 or IQ7/IQ6 Series PV and battery system with IQ Meter Collar on a separate non-utility meter pan

For notations, see [Legend](#) on page 46.

- The IQ Meter Collar works as a microgrid interconnect device (MID) to enable backup. The installation of the IQ Meter Collar enables full home monitoring.
- The IQ Combiner 6C includes an integrated load controller that can be used to control loads.
- This configuration can vary based on the IQ Meter Collar approval or specific site-related constraints. For more information, see [System variations based on IQ Meter Collar approval](#) on page 24.

See [Power Control Systems \(PCS\)](#) on page 8 for details on supported PCS configurations.

## 9.2 Grid-forming solar and battery system with IQ Meter Collar under the utility meter

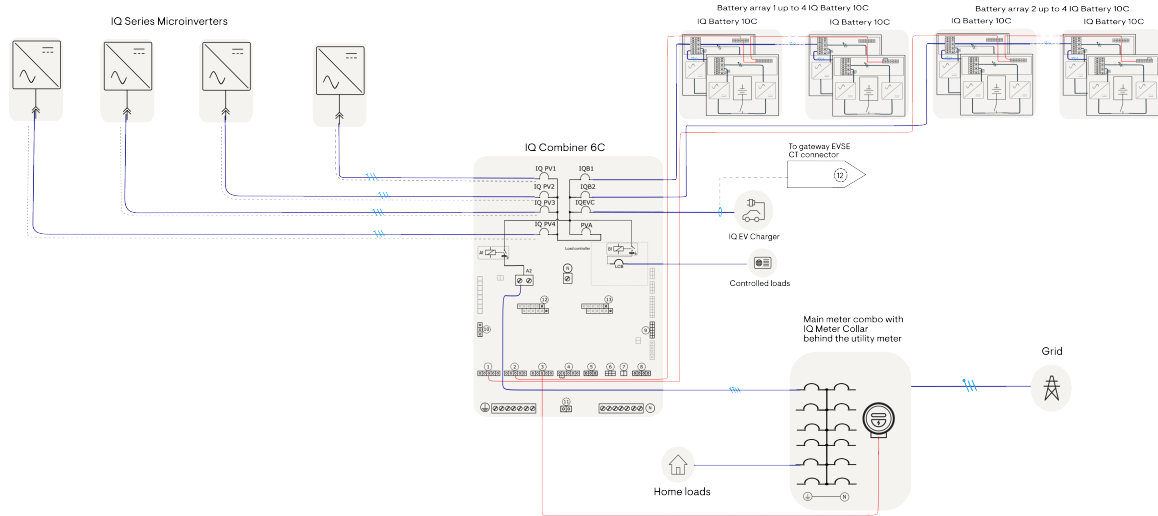

Figure 6: Grid-forming IQ8 or IQ7/IQ6 Series PV and battery system with IQ Meter Collar under the utility meter

For notations, see [Legend](#) on page 46.

- The IQ Meter Collar works as a microgrid interconnect device (MID) to enable backup. The installation of the IQ Meter Collar enables full home monitoring.
- The configuration requires utility authorization to install the IQ Meter Collar behind the utility meter.
- The IQ Combiner 6C includes an integrated load controller that can be used to control loads.
- This configuration can vary based on the IQ Meter Collar approval or specific site-related constraints. For more information, see [System variations based on IQ Meter Collar approval](#) on page 24.

See [Power Control Systems \(PCS\)](#) on page 8 for details on supported PCS configurations.

### 9.3 Grid-forming battery-only system

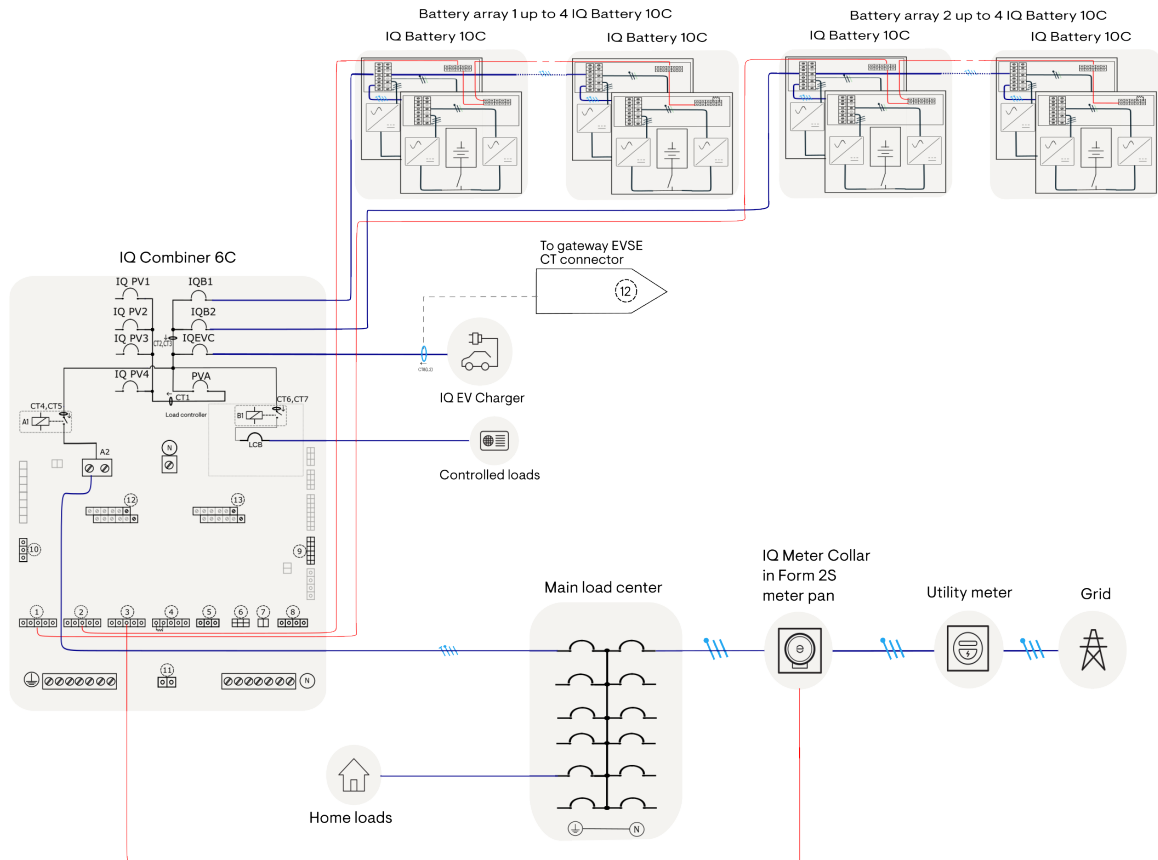

Figure 7: Grid-forming battery-only system with IQ Meter Collar in discrete meter pan

For notations, see [Legend](#) on page 46.

- The IQ Meter Collar works as a microgrid interconnect device (MID) to enable backup. The installation of the IQ Meter Collar enables full home monitoring.
- The IQ Combiner 6C includes an integrated load controller that can be used to control loads.
- This configuration can vary based on the IQ Meter Collar approval or specific site-related constraints. For more information, see [System variations based on IQ Meter Collar approval](#) on page 24.

See [Power Control Systems \(PCS\)](#) on page 8 for details on supported PCS configurations.

## 10. Backup-ready system

A backup-ready system is a grid-tied system that does not currently provide backup capability but is designed to be easily upgraded to support backup functionality in the future. If a delay in meter collar installation is expected, the system can be configured as backup-ready to allow the IQ Battery to begin providing bill-offset functionality. This enables homeowners to benefit from energy storage

capabilities while awaiting the installation of the final interconnection hardware. A backup-ready system includes the following components:

- IQ Battery 10C/10CS and IQ Combiner 6C installed.
- IQ Meter Collar present on-site (ready for utility installation under the utility meter), but not yet installed.
- Consumption CTs wired to the IQ Combiner 6C to enable battery operation while grid-connected, maximizing homeowner savings.

The following configurations can be configured as backup ready:

- [Grid-tied solar and battery system](#) on page 19.
- [Grid-tied battery-only system](#) on page 20.

## 11. System variations based on IQ Meter Collar approval

This section covers the variations in system configuration based on IQ Meter Collar approval and site-specific constraints.

### 11.1 IQ Meter Collar approved by the utility

#### 11.1.1 IQ Meter Collar installed in the main-meter combo panel

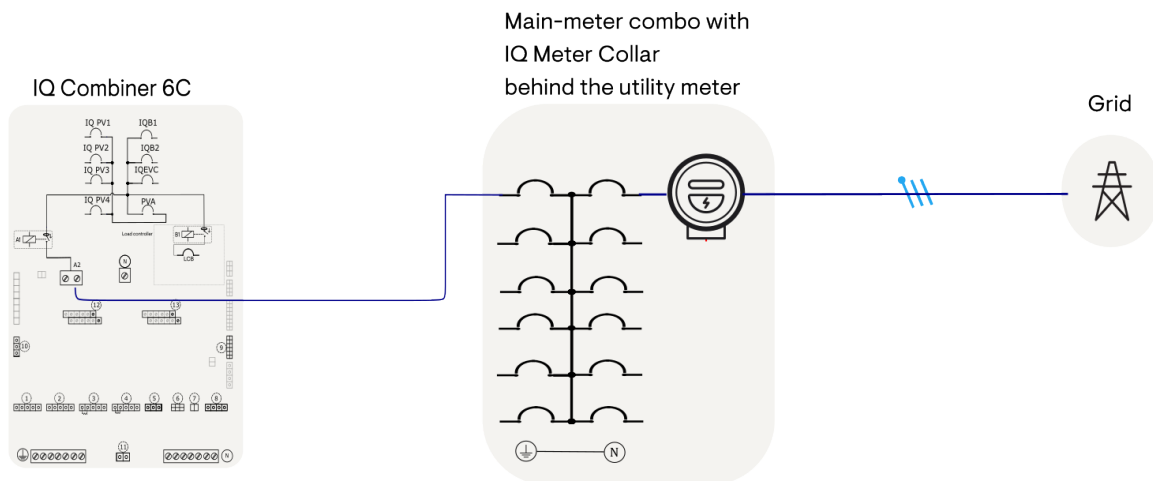

Figure 8: IQ Meter Collar installed in the main-meter combo panel

For notations, see [Legend](#) on page 46.

- The configuration requires utility authorization to install the IQ Meter Collar behind the utility meter.
- The installation must meet all the site-level utility and AHJ requirements.
- See [Grid-forming \(with backup\) system configurations](#) on page 20 for details on other system components, features, limitations, etc.

### 11.1.2 IQ Meter Collar installed in Form 2S meter panel

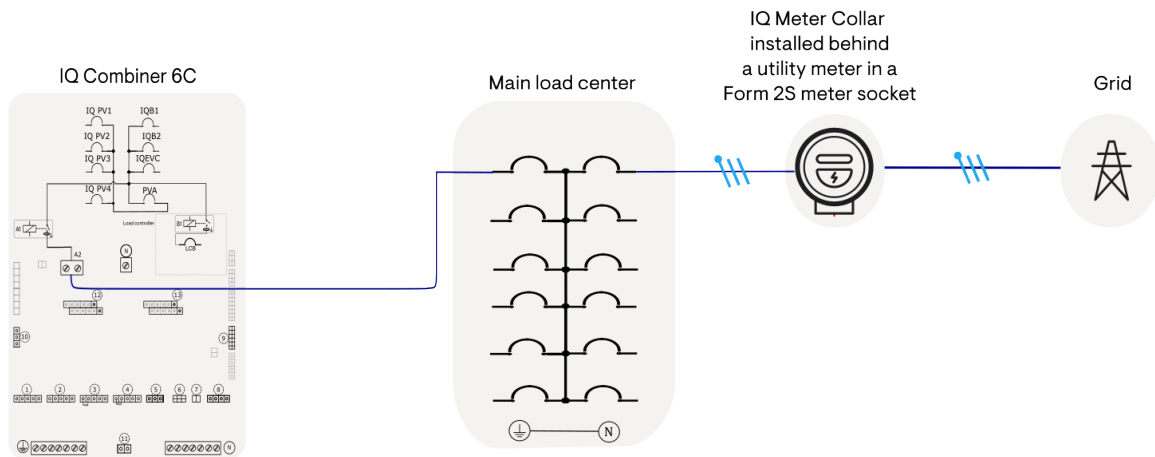

Figure 9: IQ Meter Collar installed in Form 2S meter panel

For notations, see [Legend](#) on page 46.

- The configuration requires utility authorization to install the IQ Meter Collar behind the utility meter.
- The installation must meet all the site-level utility and AHJ requirements.
- See [Grid-forming \(with backup\) system configurations](#) on page 20 for details on other system components, features, limitations, etc.

## 11.2 IQ Meter Collar not approved by utility

### 11.2.1 Load-side meter socket

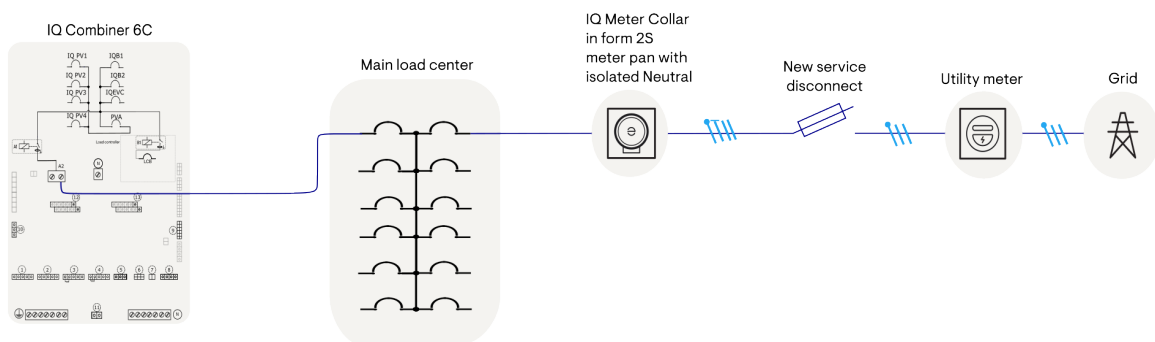

Figure 10: Load-side meter pan

**NOTE:** The IQ Meter Collar is installed on the load side of the service disconnect. This placement may be disallowed by some utilities or AHJs. Always confirm local code compliance before installation.

For notations, see [Legend](#) on page 46.

- Refer to the [Grid-forming \(with backup\) system configurations](#) on page 20 for details on other system components, features, limitations, etc.

- A panel with an isolated neutral and a ground connection to the panel chassis/body is required. Alternatively, if the neutral is passed through (i.e., not terminated on the panel), the ground must still be connected to the chassis/body.

### 11.2.2 Supply-side meter socket

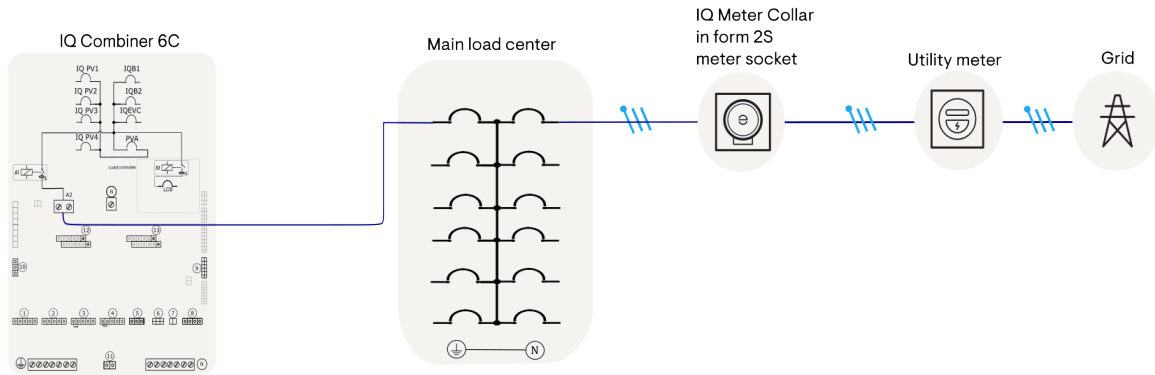

Figure 11: Supply-side meter pan

**NOTE:** If the IQ Meter Collar is not utility-approved, it must typically be installed on a separate socket on the home/load side of the service disconnect. Installation on the utility side of the service disconnect is permitted only if allowed by the utility and/or AHJ. Always confirm local code compliance before installation.

For notations, see [Legend](#) on page 46.

Refer to the [Grid-forming \(with backup\) system configurations](#) on page 20 for details on other system components, features, limitations, etc.

## 12. Supported partial home backup configurations

This section describes the supported partial home backup configurations for systems with 400 A and 200 A service supplies. The guidance provided for 400 A supplies may also apply to larger ampacity split-phase systems, where applicable.

## 12.1 400 A supply configuration #1

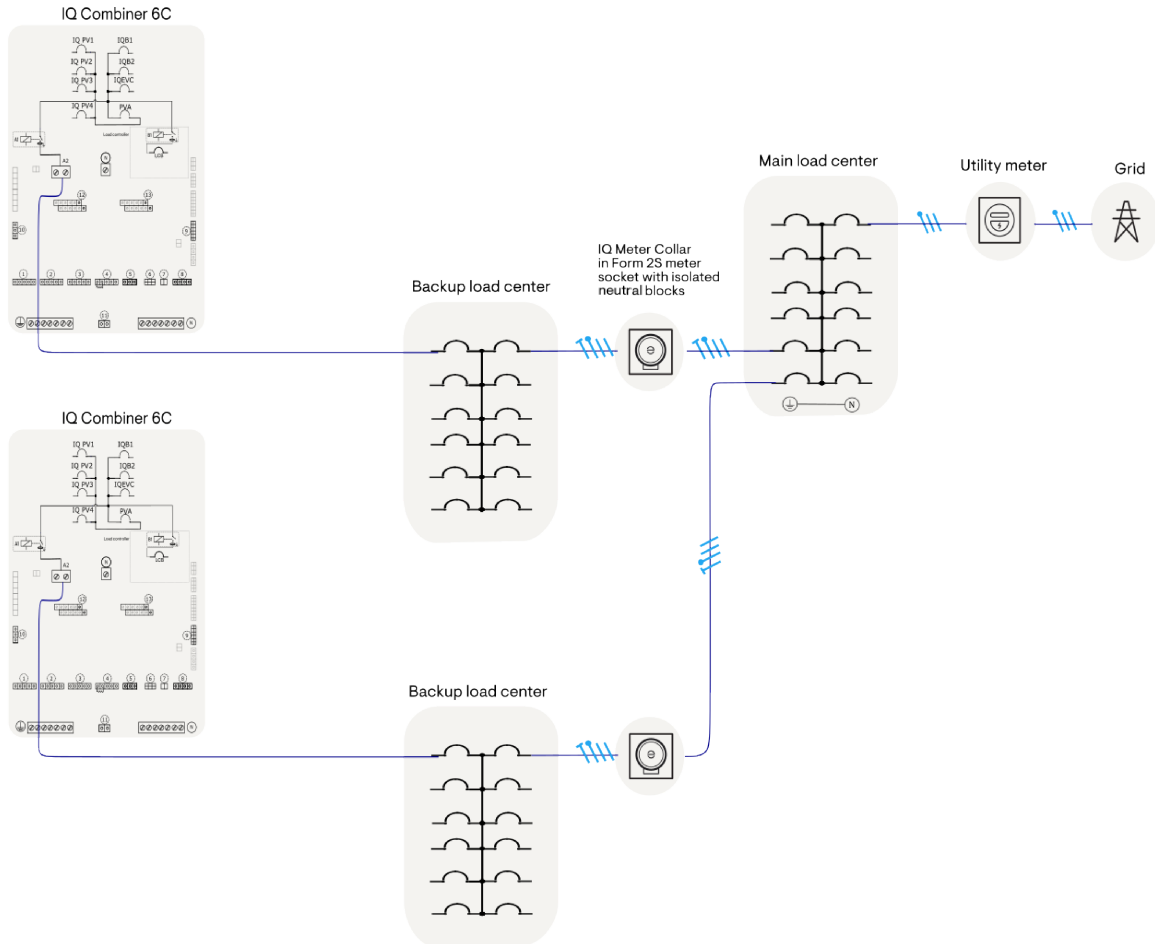

Figure 12: 400 A supply configuration #1: Two independent backup systems connected to the main load center in parallel

For notations, see [Legend](#) on page 46.

A panel with an isolated neutral and a ground connection to the panel chassis/body is required. Alternatively, if the neutral is passed through, that is, not terminated on the panel, the ground must still be connected to the chassis/body.

- ✔
**NOTE:** Install a PLC filter (Q-LCF-064-1P) in one of the IQ Combiner 6C units, inline with the PV aggregate breaker, using insulated splices. Limit the number of microinverter branch circuits on this combiner to four ( $\leq 15.36$  kW).

## 12.2 400 A supply configuration #2

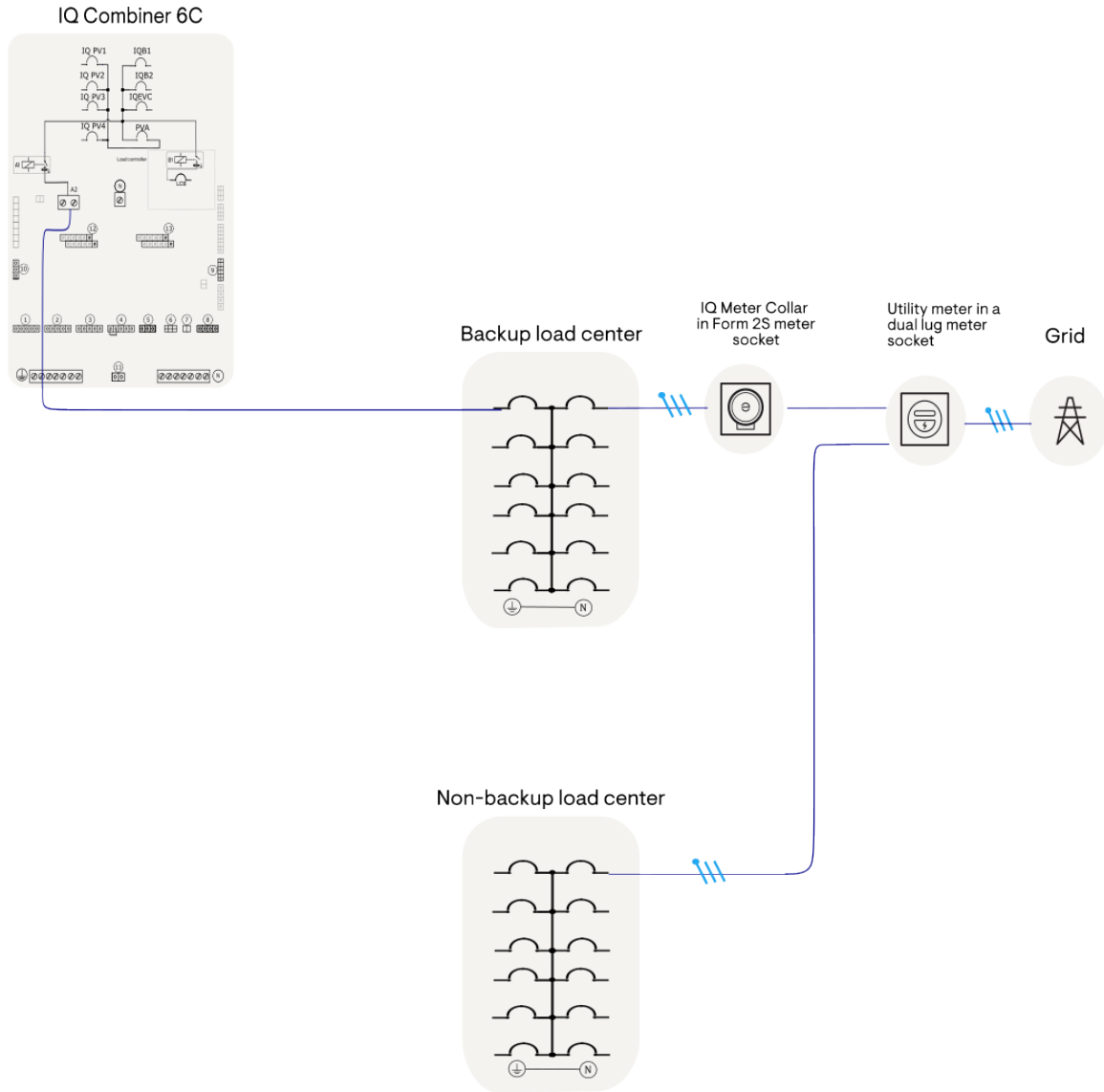

Figure 13: 400 A supply configuration #2: Backup and non-backup systems connected to double-lug meter pan

For notations, see [Legend](#) on page 46.



**NOTE:** Install a PLC filter (Q-LCF-064-1P) in one of the IQ Combiner 6C units, inline with the PV aggregate breaker, using insulated splices. Limit the number of microinverter branch circuits on this combiner to four ( $\leq 15.36$  kW).

### 12.3 200 A supply configuration

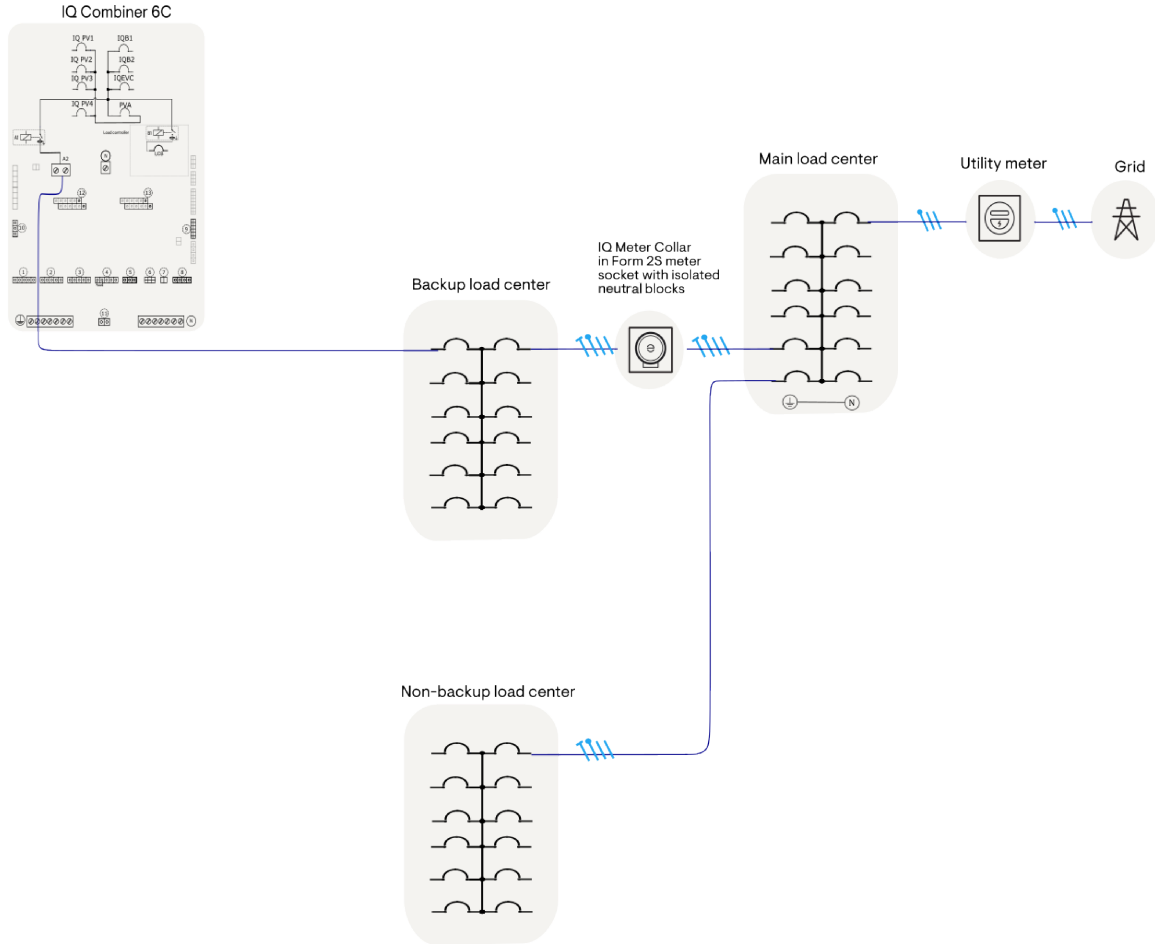

Figure 14: 200 A supply configuration

For notations, see [Legend](#) on page 46.

## 13. Legacy and third-party PV support

### 13.1 Grid-forming legacy and third-party PV support/NEM expansion

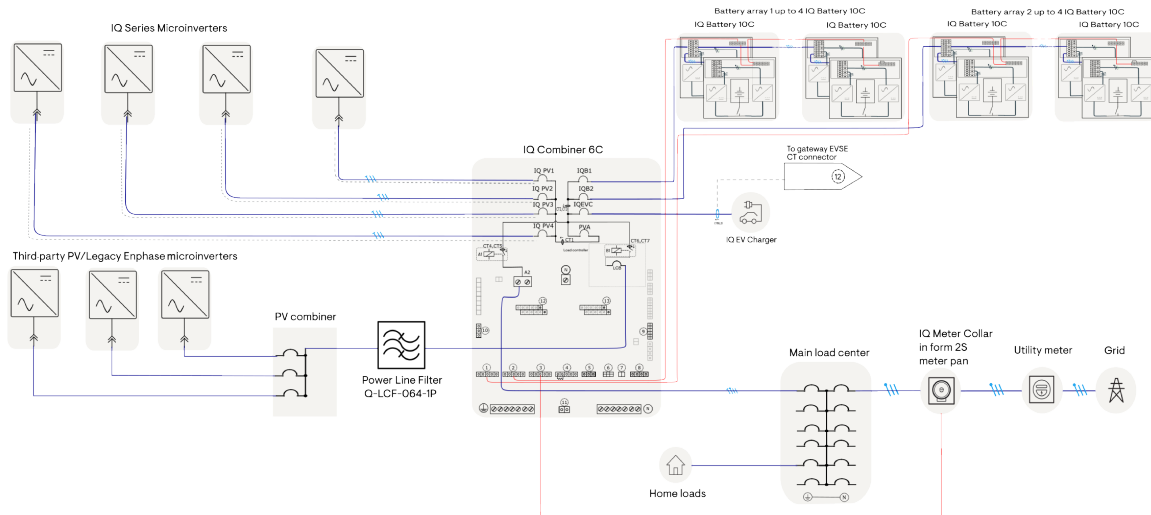

Figure 15: Grid-forming legacy and third-party PV support/NEM expansion

For notations, see [Legend](#) on page 46.



**NOTE:** Third-party or legacy Enphase PV systems connected to the integrated load controller act as uncontrolled power sources on the load side. Their maximum size must follow these rules:

1. Breaker sizing: The breaker feeding the IQ Combiner 6C in the backup panel must be equal to or larger than the integrated load controller breaker. This prevents the breaker from tripping due to backfeed by the uncontrolled source.
2. NEC 2023 705.15(B) – 120% rule: The combined ratings of the main breaker (primary source) feeding the backup panel and the integrated load controller breaker in the IQ Combiner 6C (additional source) must not exceed 120% of the busbar rating when backfed. Review NEC 705.15(B) for requirements on breaker placement and so on.

- Legacy Enphase/third-party PV systems are integrated via the integrated load controller.
- For NEM expansion or NEM Multi Tariff (MT) systems, the legacy PV is not used to charge batteries even when the system is on grid. The economic benefit to the homeowner is maximized by exporting all legacy PV to the grid. The new PV and battery system operates as zero-export and cannot export to grid.
- For non-NEM MT expansion systems, the system uses legacy or third-party PV to charge batteries when on grid. The new PV and battery can export to grid. However, the legacy or third-party PV cannot retain its NEM 1/2 status.
- Load shedding is not supported in systems that include legacy Enphase microinverters or third-party PV systems.
- The system will disconnect the legacy Enphase/third-party PV systems when transitioning to off-grid operation.
- The IQ Meter Collar can be installed beneath the utility meter, provided the utility allows its placement within the same meter pan.
- A Power Line Filter (Q-LCF-064-1P) is needed when the legacy Enphase system includes IQ Series Microinverters.

- For NEM expansion systems, NEM integrity mode must be enabled during commissioning using the Enphase Installer App.
- No additional CTs are required to measure the production of third-party or legacy Enphase PV systems. The built-in load CTs within the integrated load controller will handle production measurement and support NEM integrity mode (if needed).

### 13.2 Grid-tied NEM expansion configuration

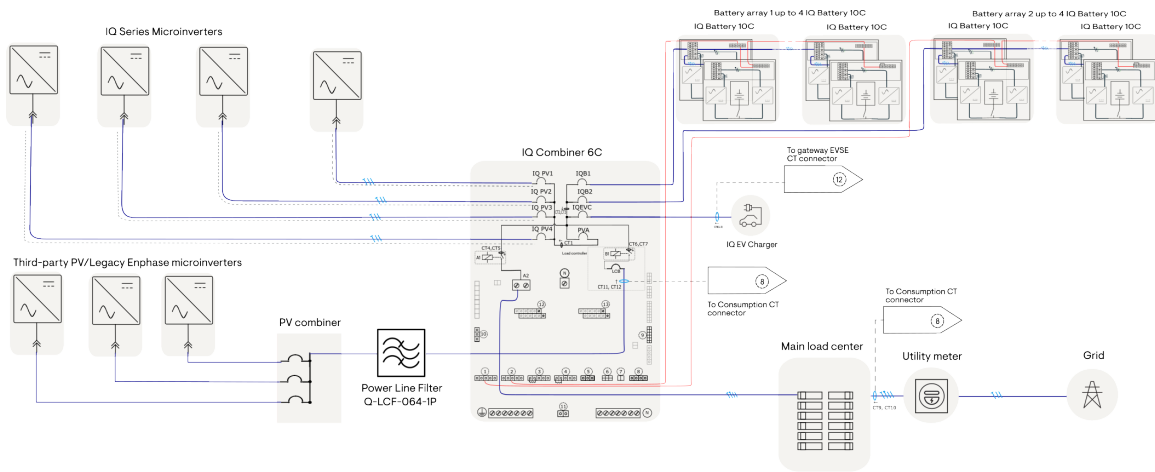

Figure 16: Grid-tied NEM expansion configuration

For notations, see [Legend](#) on page 46.



**NOTE:** Third-party or legacy Enphase PV systems connected to the integrated load controller act as uncontrolled power sources on the load side. Their maximum size must follow these rules:

1. Breaker sizing: The breaker feeding the IQ Combiner 6C in the backup panel must be equal to or larger than the integrated load controller breaker. This prevents the breaker from tripping due to backfeed by the uncontrolled source.
2. NEC 2023 705.15(B) – 120% rule: The combined ratings of the main breaker (primary source) feeding the backup panel and the integrated load controller breaker in the IQ Combiner 6C (additional source) must not exceed 120% of the busbar rating when backfed. Review NEC 705.15(B) for requirements on breaker placement and so on.

- For NEM expansion or NEM Multi Tariff (MT) systems, the legacy PV is not used to charge batteries even when the system is on grid. The economic benefit to the homeowner is maximized by exporting all legacy PV to the grid. The new PV and battery system operates as zero-export and cannot export to grid.
- For non-NEM MT expansion systems, the system uses legacy or third-party PV to charge batteries when on grid. The new PV and battery can export to grid. However, the legacy or third-party PV cannot retain its NEM 1/2 status.
- An external Consumption CT at the point of common coupling, along with a third-party PV Production CT, must be installed. Both must be CT-200-CLAMP models and connected in parallel to the Consumption CT connector.
- The load/PV CT from the integrated load controller must be safely shorted using a wire nut.
- Configurations without the IQ Battery are supported, enabling the use of IQ Series Microinverters along with third-party or legacy Enphase microinverters. Refer to the *IQ Combiner 6C quick installation guide* for details.

- A Power Line Filter (Q-LCF-064-1P) is needed when the legacy Enphase system includes IQ Series Microinverters.
- For NEM expansion systems, NEM integrity mode must be enabled during commissioning using the Enphase Installer App.

### 13.3 Grid-tied non-NEM expansion configuration

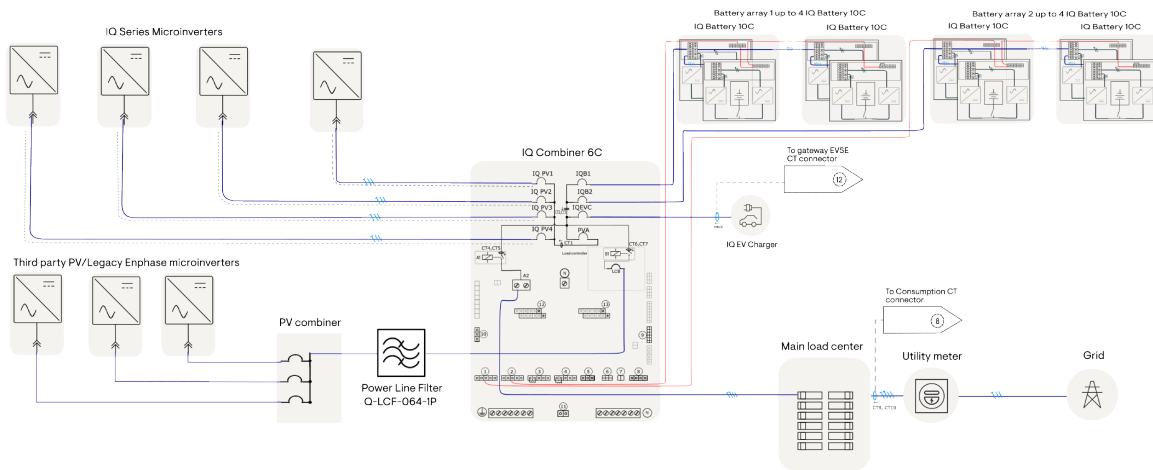

Figure 17: Grid-tied non-NEM expansion configuration

For notations, see [Legend](#) on page 46.



**NOTE:** Third-party or legacy Enphase PV systems connected to the integrated load controller act as uncontrolled power sources on the load side. Their maximum size must follow these rules:

1. Breaker sizing: The breaker feeding the IQ Combiner 6C in the backup panel must be equal to or larger than the integrated load controller breaker. This prevents the breaker from tripping due to backfeed by the uncontrolled source.
  2. NEC 2023 705.15(B) – 120% rule: The combined ratings of the main breaker (primary source) feeding the backup panel and the integrated load controller breaker in the IQ Combiner 6C (additional source) must not exceed 120% of the busbar rating when backfed. Review NEC 705.15(B) for requirements on breaker placement and so on.
- For non NEM MT expansion systems, the system uses legacy or third-party PV to charge batteries when on grid. The new PV and battery can export to grid. However, the legacy or third-party PV cannot retain its NEM 1/2 status.
  - The load/PV CT from the integrated load controller must be safely shorted using a wire nut.
  - Configurations without the IQ Battery are supported, enabling the use of IQ Series Microinverters along with third-party or legacy Enphase microinverters.
  - Power Line Filter Q-LCF-064-1P is required when the legacy Enphase system includes IQ Series Microinverters.

## 14. Supply-side connection

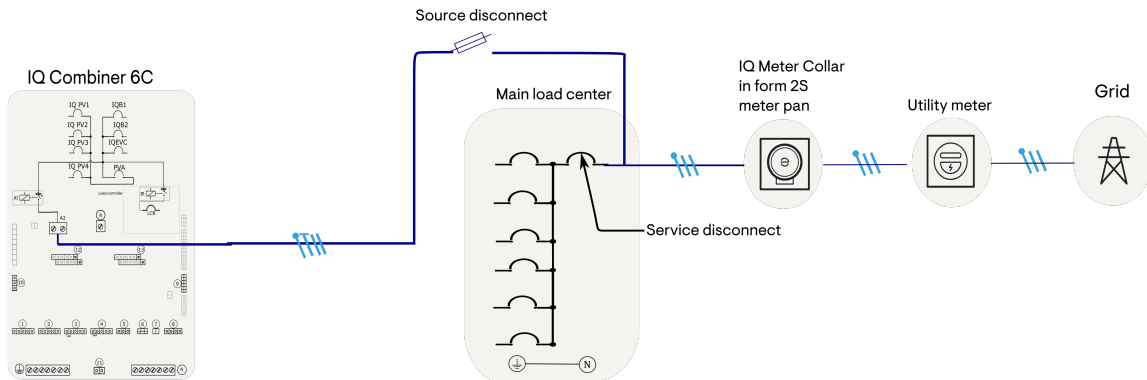

Figure 18: Supply-side connection

For notations, see [Legend](#) on page 46.

- The IQ Meter Collar and IQ Combiner 6C can be connected as supply-side equipment when properly installed:
  - IQ Meter Collar is labeled as service entrance rated, not service equipment.
  - Source disconnect and overcurrent protection for IQ Combiner 6C must be service entrance rated.
  - Grounded and bonded in compliance with NEC Article 250.
  - ESS charging may need to comply with NEC Article 750.30 to ensure no overload occurs.
- Where load control or Electric Vehicle Supply Equipment (EVSE) is connected, the IQ Combiner 6C no longer constitutes a pure supply-side connection. In such cases:
  - The source disconnect is classified as an additional service disconnect handle.
  - Grouping of disconnects must comply with NEC 230.71 and 230.72.
  - Service load calculations according to NEC 230.90 must be updated accordingly.

See [Power Control Systems \(PCS\)](#) on page 8 for details on supported PCS configurations.

## 15. External shutdown initiators and disconnect options

If the IQ Combiner 6C is installed in a readily accessible outdoor location, the PV aggregate breaker also functions as the rapid shutdown (RSD) initiator for grid-forming systems. However, if the IQ Combiner 6C is not installed in an accessible outdoor location, or if local regulations require a visible blade disconnect, an external disconnect should be installed to serve as the RSD initiator.

The following are externally installed isolation/shutdown means supported for grid-tied/grid-forming systems:

- Grid-side disconnect (on backfeed to backup panel)
- PV disconnect in line with the PV aggregate breaker
- PV disconnect in line with external combiner (2-pole)
- PV disconnect in line with external combiner (3-pole)

Refer to the [System shutdown behavior](#) on page 37 section to understand the system shutdown behavior for grid-tied and grid-forming systems, and to learn which components are shut down or disconnected by each initiator.

### 15.1 Grid-side disconnect (on the backfeed to the backup panel)

A 3-pole disconnect is placed on the backfeed from the combiner to the backup panel, with the 2-pole connected to the backfeed panel and the third pole connected to the AC sense header on the IQ Combiner 6C.

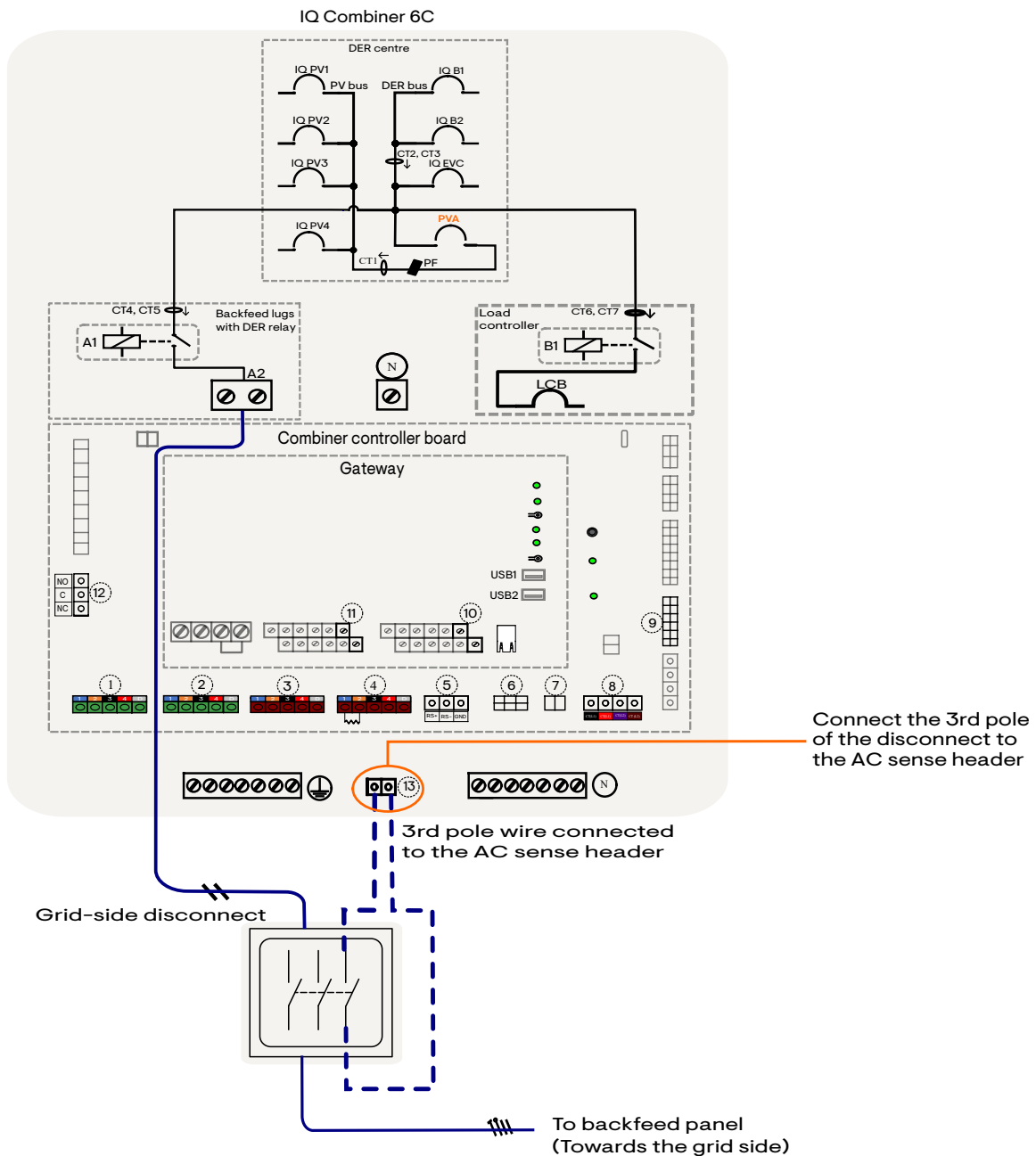

Figure 19: Grid-side disconnect (on the backfeed to the backup panel)

### 15.2 PV disconnect in line with the PV aggregate breaker

The 2-pole disconnect is placed between the IQ Combiner 6C and the PV branch circuits.

Install a 2-pole disconnect by looping the wire from the PV aggregate breaker to the disconnect. Connect the wires from the PV aggregate breaker to the external disconnect using insulated inline splice connectors.

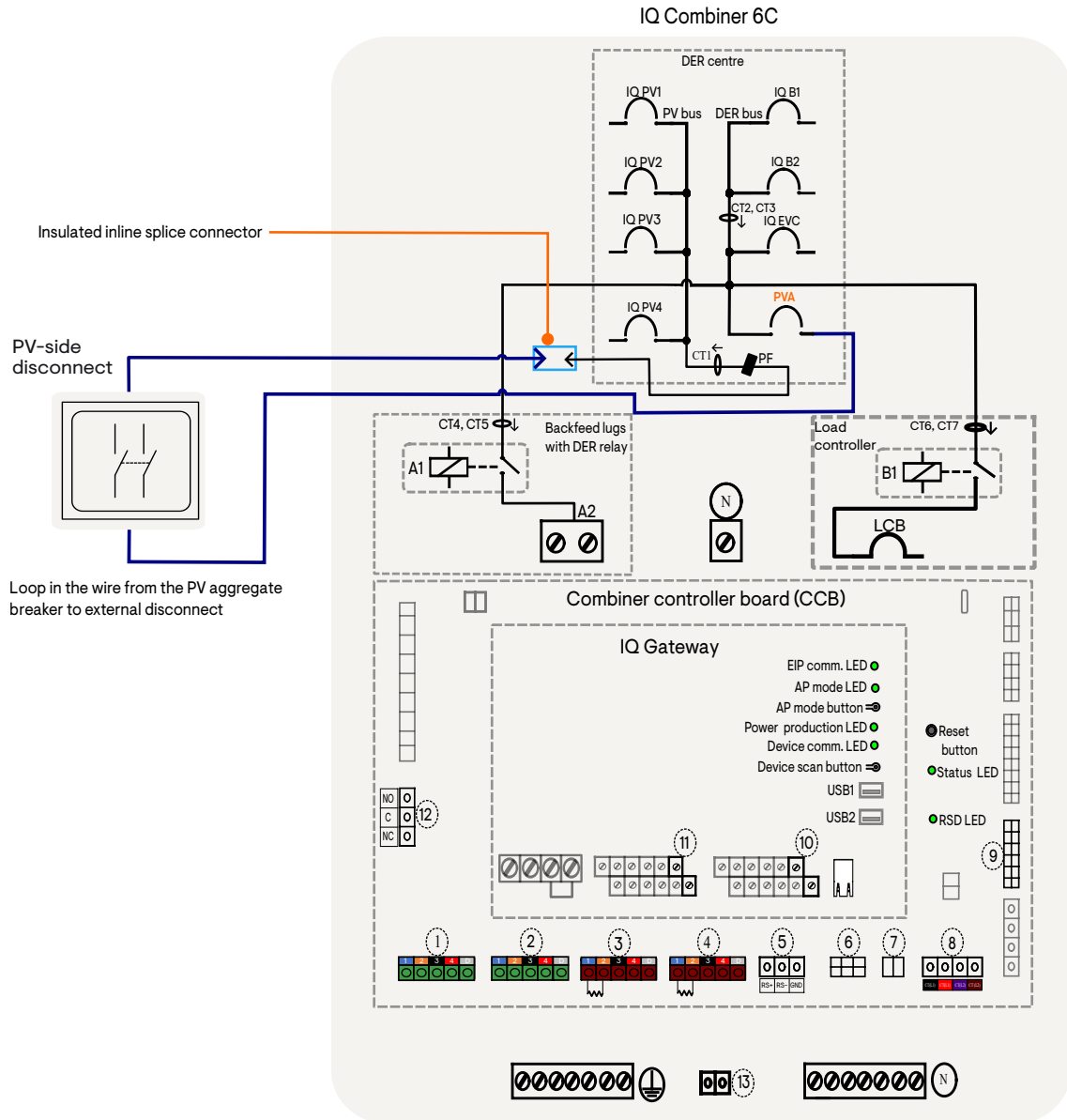

Figure 20: PV disconnect in line with PV aggregate breaker

### 15.3 PV disconnect in line with the external combiner (2-pole)

The 2-pole disconnect is placed between the IQ Combiner 6C and the external combiner, with the external combiner aggregation landing on PV4 spaces within IQ Combiner 6C.

✓ **NOTE:** A 2-pole grid-side disconnect can be used for a grid-tied (non-backup) system, without a connection to the AC sense header.

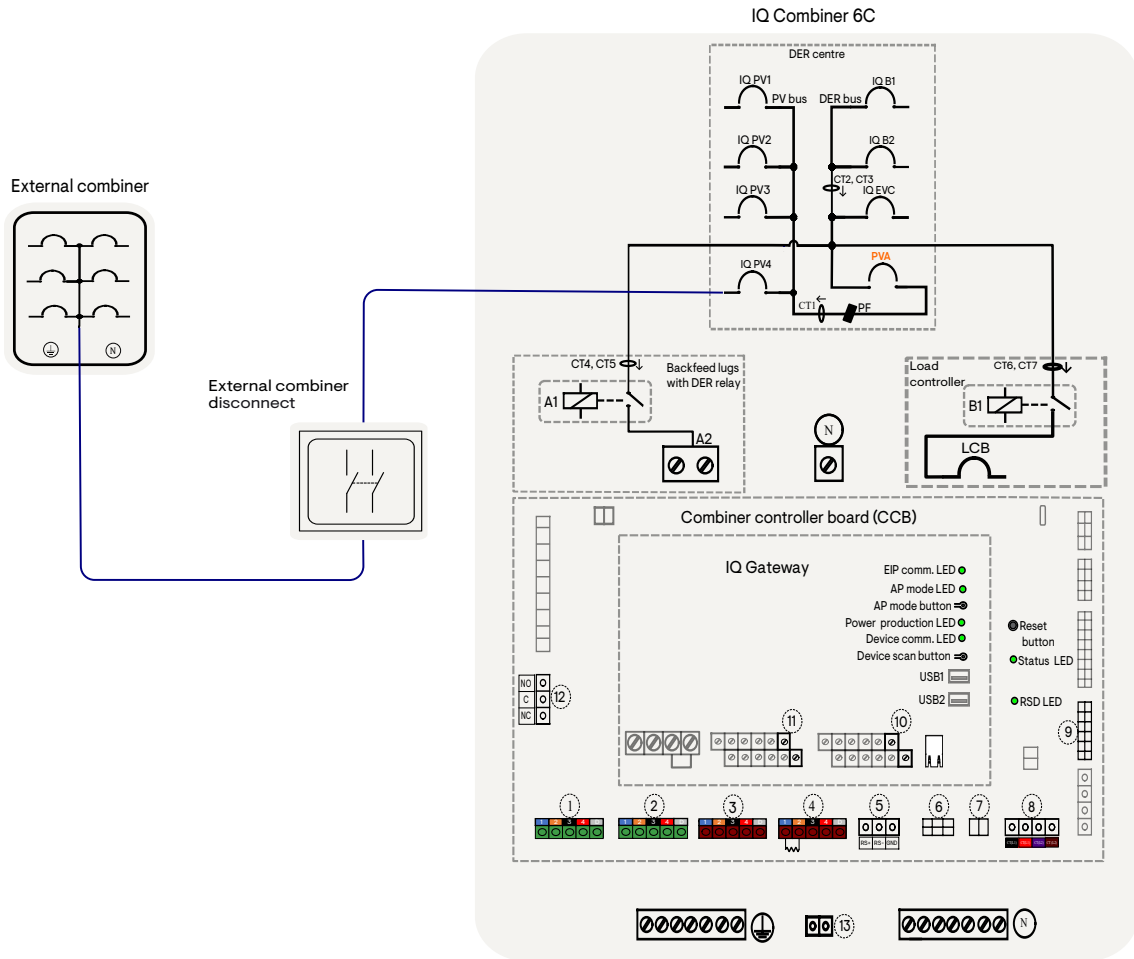

Figure 21: PV disconnect in line with external combiner (2-pole)

### 15.4 PV disconnect in line with the external combiner (3-pole)

The 3-pole disconnect is placed between the IQ Combiner 6C and the external combiner, with the external combiner aggregation landing on PV4 spaces within IQ Combiner 6C. Two poles are wired to the external combiner, and the third pole is wired to the AC sense header, facilitating the energy storage system (ESS) emergency shutdown.

✓ **NOTE:** A 3-pole PV-side disconnect can also be used, with the third pole connected to the AC sense header.

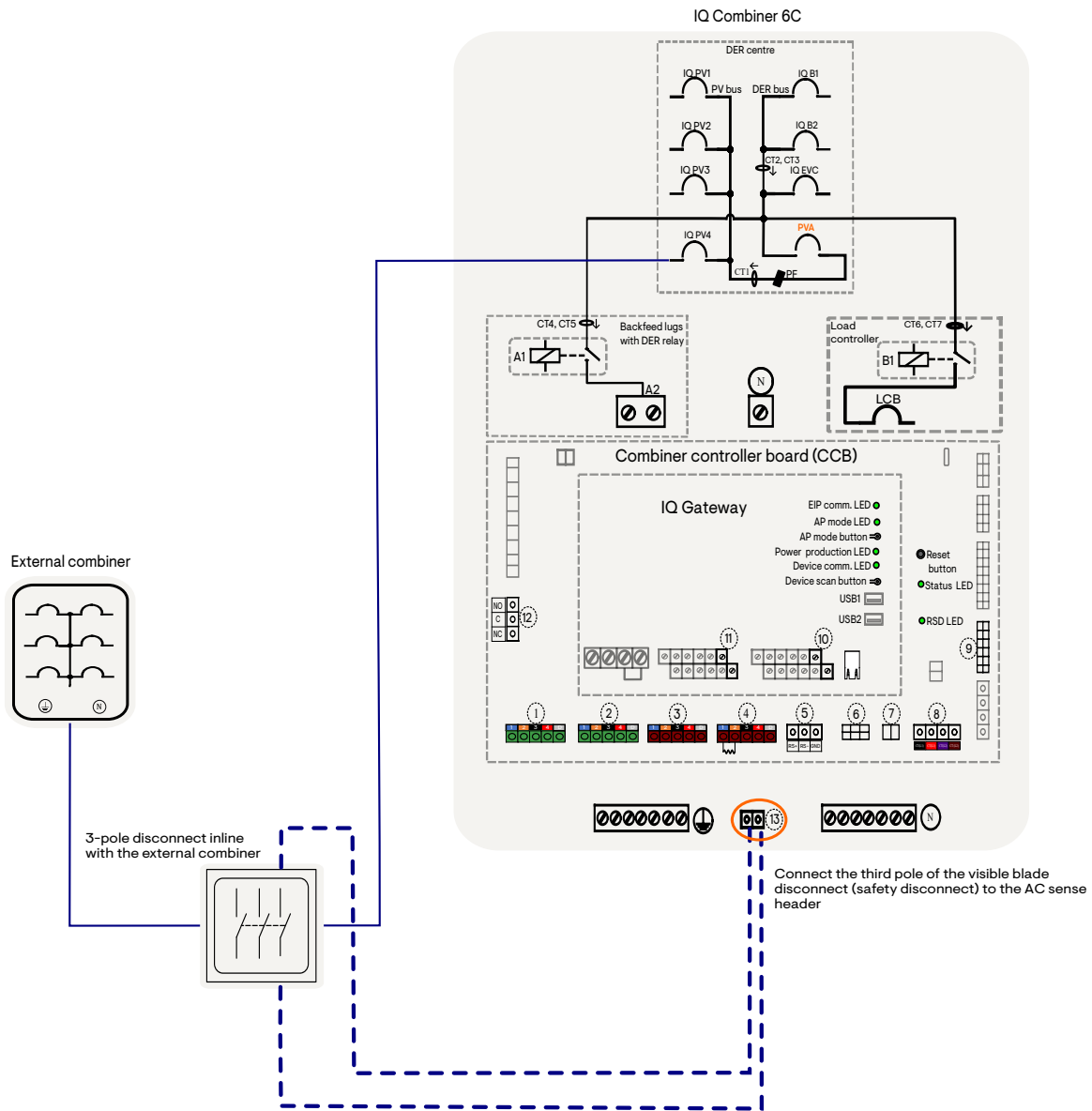

Figure 22: PV disconnect in line with external combiner (3-pole)

## 16. System shutdown behavior

The 4th-generation Enphase Energy Systems provide various methods for achieving isolation and system shutdown. The behavior of the system in providing these functions varies depending on the installed configuration and the disconnect options chosen.

## 16.1 Grid-tied (non-backup) system shutdown behavior

### 16.1.1 Normal behavior

A grid-tied system operates with microinverters that follow the grid reference voltage. Any loss of grid reference voltage due to an outage or abnormality causes the microinverters and batteries to stop producing power.

### 16.1.2 Initiators in the grid-tied system

In an Enphase Energy System, multiple initiators are involved in system shutdown and isolation. These include:

- PV breakers labeled as PV1, PV2, PV3, and PV4 used to isolate PV circuits
- Battery breakers labeled B1 and B2 used to isolate battery circuits
- A PV aggregate breaker labeled as PVA, which also functions as a shutdown initiator
- Battery DC switches used to disconnect batteries
- A backfeed breaker used to disconnect the IQ Combiner 6C from the main panel
- External disconnects
  - Grid-side disconnect (on the backfeed to the backup panel)
  - PV-side disconnect inline with the PV aggregate breaker (2-pole)
  - PV disconnect inline with external combiners (2-pole or 3-pole)



**NOTE:** The following figure illustrates a site setup utilizing a PV-side disconnect inline with the PV aggregate breaker. However, other configurations may be used depending on site-specific requirements.

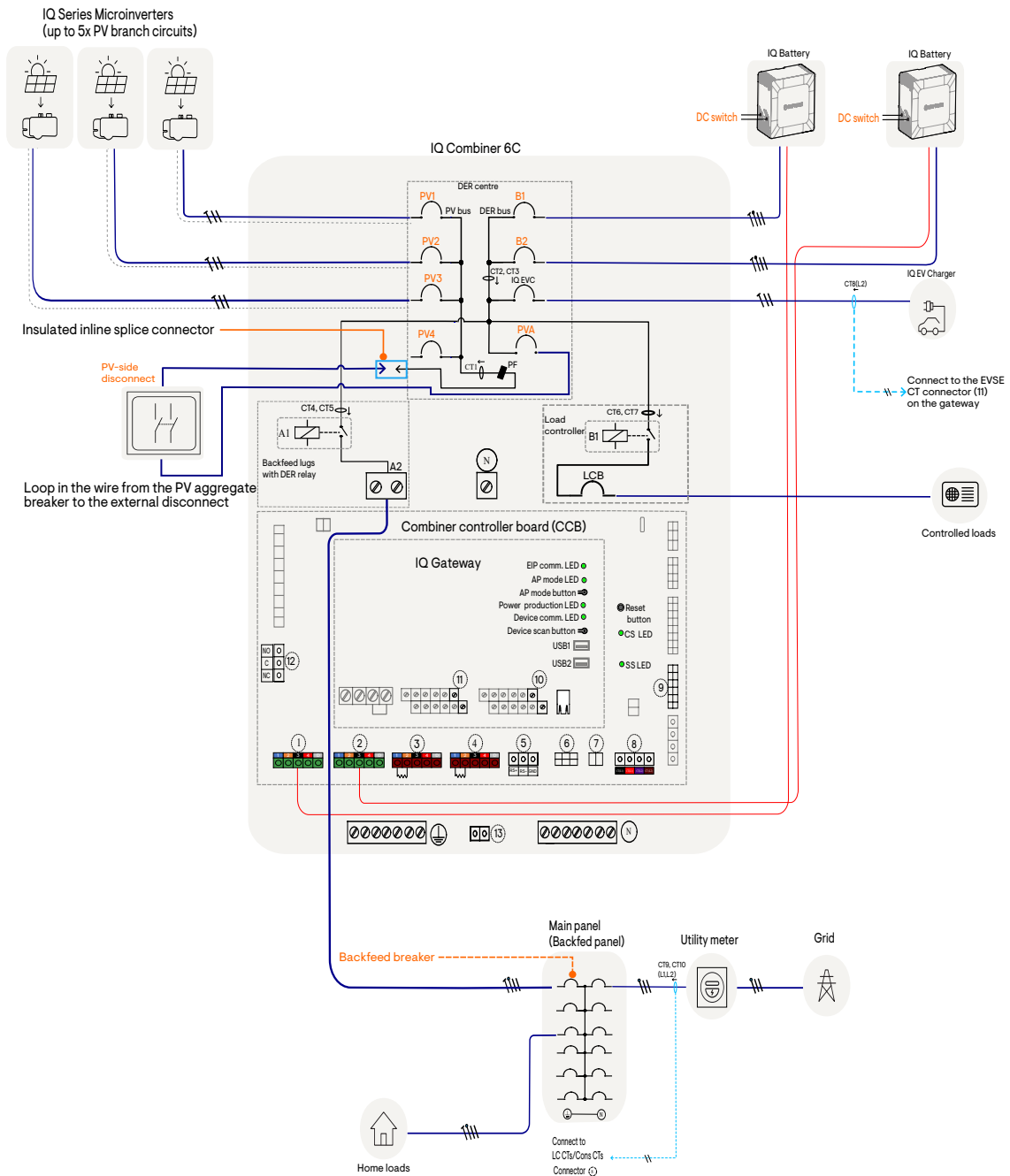

Figure 23: A site setup utilizing a PV-side disconnect inline with the PV aggregate breaker

### 16.1.3 Shutdown mechanism

For shutdown, the system senses the opening and closing of the PV aggregate breaker to initiate the shutdown procedure. The combiner also detects any loss of continuity between the two terminals on the AC sense header when a third pole of the disconnect is connected to it.

### 16.1.4 Grid-tied system behavior

The following table illustrates the system's behavior when any of the initiators is used for system shutdown, assuming the grid is available, and the battery State of Charge (SoC) is within normal limits.

Table 8: Grid-tied (non-backup) system shutdown behavior

Location in the system	Initiators	PV isolated from grid	PV isolated from batteries	Batteries isolated from grid	DER relay status post initiation	Battery output voltage (V) <sup>10</sup>	PV voltage post initiation (V) <sup>11</sup>
IQ Combiner 6C	PV aggregate breaker	Yes	Yes	No	Closed	240	0
	All PV branch circuit breakers (PV1/PV2/PV3/PV4)	Yes	Yes	No	Closed	240	0
	Battery breaker(s)	No	Yes	Yes	Closed	0	240
Battery	Battery switch(s)	No	Yes	Yes	Closed	0 <sup>12</sup>	240
Main panel	Backfeed breaker	Yes	No	Yes	Closed	0	0
External disconnect <sup>13</sup>	Grid-side disconnect (on backfeed to backup panel)	Yes	No	Yes	Closed	0	0
	PV disconnect in line with PV aggregate breaker	Yes	Yes	No	Closed	0 <sup>12</sup>	0
	PV disconnect in line with the external combiner (2-pole)	Yes	Yes	No	Closed	240	0
	PV disconnect in line with the external combiner (3-pole)	Yes	Yes	No	Closed	240	0

For example, when the PV aggregate breaker is turned OFF in a grid-tied system, the following occurs:

- Rapid shutdown events are triggered by the system.
- DER relay remains closed.
- The battery’s AC terminals will remain energized when grid power is present. However, the battery system will not export energy to the grid and cannot operate independently in the absence of grid power.
- The photovoltaic (PV) system is electrically isolated from both the battery storage and the premises wiring.

<sup>10</sup> Voltage measured at the battery AC terminals.

<sup>11</sup> Voltage measured at PV inverter AC terminals.

<sup>12</sup> Battery will not energize its AC terminals; however, these may still remain energized by the utility grid.

<sup>13</sup> Location and option of disconnects may vary based on system configurations.

## 16.2 Grid-forming (backup) system shutdown behavior

### 16.2.1 Normal behavior

When connected to the grid, microinverters and batteries follow the grid reference voltage. During microgrid formation, batteries establish their own grid, and the PV system uses the battery as a reference.

### 16.2.2 Initiators in the grid-forming system

In an Enphase Energy System, multiple initiators are involved in system shutdown and isolation. These include:

- PV breakers labeled as PV1, PV2, PV3, and PV4 used to isolate PV circuits
- Battery breakers labeled B1 and B2 used to isolate battery circuits
- A PV aggregate breaker labeled as PVA, which also functions as a shutdown initiator
- Battery DC switches used to disconnect batteries
- A backfeed breaker used to disconnect the IQ Combiner 6C from the main panel
- External disconnects
  - Grid-side disconnect (on the backfeed to the backup panel)
  - PV-side disconnect inline with the PV aggregate breaker (2-pole)
  - PV disconnect inline with external combiners (2-pole or 3-pole)



**NOTE:** The following figure illustrates a site setup utilizing a grid-side disconnect (on the backfeed to the backup panel). However, other configurations may be used depending on site-specific requirements.

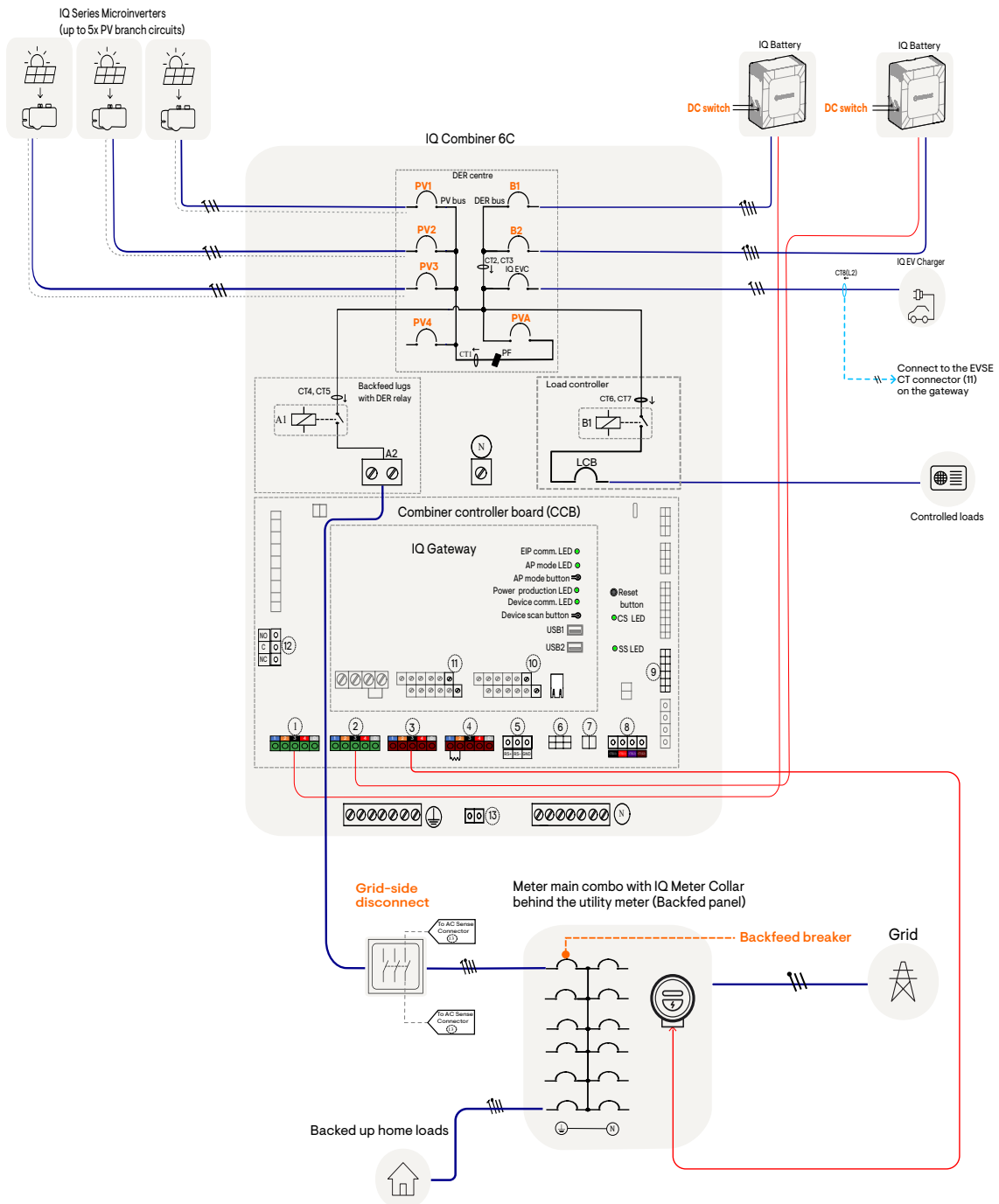

Figure 24: A site setup utilizing a grid-side disconnect

### 16.2.3 Shutdown mechanism

The system senses the opening and closing of the PV aggregate breaker to initiate the shutdown procedure. The combiner detects any loss of continuity between the two terminals of the AC sense header when a third pole of the disconnect is connected to it.

### 16.2.4 Grid-forming system behavior

The following table illustrates the system's behavior when any of the initiators is used for system shutdown, assuming the grid is available, the battery State of Charge (SoC) is within normal limits, and the system includes an IQ8 Microinverter or higher.

Table 9: Grid-forming (backup) system shutdown behavior

Location in the system	Initiators	PV isolated from grid	PV isolated from batteries	Batteries isolated from grid	DER relay status after initiation	Battery output voltage (V) <sup>14</sup>	PV voltage (V) <sup>15</sup>
IQ Combiner 6C	PV aggregate breaker	Yes	Yes	Yes	Open	<30	<30
	All PV branch circuit breakers (PV1/PV2/PV3/PV4)	Yes	Yes	No	Closed	240	<30
	Battery breaker(s)	No	Yes	Yes	Closed	<30	240
Battery	Battery switch(s)	No	Yes	Yes	Closed	0	240
Main panel	Backfeed breaker	Yes	No	Yes	Open	<30	<30
External disconnect <sup>16</sup>	Grid-side disconnect (on backfeed to backup panel)	Yes	No	Yes	Open	<30	<30
	PV disconnect in line with PV aggregate breaker	Yes	Yes	Yes	Open	<30	<30
	PV disconnect in line with the external combiner (2-pole)	Yes	Yes	No	Closed	240	<30
	PV disconnect in line with the external combiner (3-pole)	Yes	Yes	Yes	Open	<30	<30



**IMPORTANT:** Use battery breakers in addition to this shutdown initiator if doing maintenance on battery AC wires.

For example, when shutdown is initiated through a PV aggregate breaker for a grid-forming system, the following occurs:

<sup>14</sup> Voltage measured at the battery AC terminals.

<sup>15</sup> Voltage measured at PV inverter AC terminals.

<sup>16</sup> Location and options of disconnects may vary based on system configurations.

- Rapid shutdown events are triggered by the system.
- The DER relay opens for grid-forming systems.
- The battery voltage drops to a touch-safe level, completely stopping power export from the terminals.
- The photovoltaic (PV) system is electrically isolated from both the battery storage and the premises wiring. Upon losing reference signals from the battery and the grid, the PV system reaches a touch-safe voltage level, enhancing safety for maintenance personnel and first responders.

## Appendix A









---

### Abbreviations

Abbreviation	Description
DER	Distributed energy resource
EES	Enphase Energy System
kW	Kilowatt
kVA	Kilovolt-ampere
MID	Microgrid interconnect device
NEC	National Electrical Code
NFT	Neutral forming transformer
OCPD	Overcurrent protection device
PV	Photovoltaic
RSD	Rapid shutdown device
SKU	Stock keeping unit

## Appendix B

### Legend

Symbols	Description
	Equipment ground conductor
	Grounded conductor (Neutral)
	Ungrounded conductor
	Field-wired conductors
	Neutral sense
	Phase detection
	Relay
	Breaker

Connectors	Description
1	IQ Battery control header - 1
2	IQ Battery control header - 2
3	IQ Collar control header
4	Spare control header (not to be used)
5	RS485
6	Ride-through (RT) power supply accessory
7	Rope CT - power supply
8	Integrated load monitoring CT/External Consumption CT connector
9	Load relay connector (accessory)
10	NO/NC dry contact relay
11	AC sense
12	EVSE CT
13	NO dry contact relay

Connectors	Description
14	Battery power terminal
15	Battery control terminal
16	Battery control terminal with termination resistor

Label	Description
A1	DER relay
A2	Backfeed lugs
B1	Load control relay
B2	Up to 1 × 80 A load control breaker
CT1	Integrated revenue-grade PV CT (L2)
CT2,CT3	Integrated revenue-grade battery CTs (L1, L2)
CT4,CT5	Integrated backfeed CTs (L1, L2)
CT6,CT7	Integrated load control CTs (L1, L2)
CT8	Field-installed EVSE CT (L2)
CT9, CT10	Field-installed Consumption CTs (L1, L2)
CT11, CT12	Field-installed third-party PV CTs (L1, L2)
IQ PV1, IQ PV2, IQ PV3, IQ PV4	Up to 4 × 20 A for PV strings or up to 3 × 20 A breaker and 1 × 20/20 A quad breaker
IQB1, IQB2	Up to 2 × 80 A for IQ Battery breaker
IQEVC	Up to 1 × 60 A for 1 × IQ EV Charger breaker
LCB	Up to 1 × 80 A for load control on non-backup loads
PF	PLC ferrite at PV aggregate (L2)
PVA	Pre-installed 60 A PV aggregate breaker as rapid shutdown initiator (RSD); can be replaced by 80 A, 100 A breakers

## Appendix C

### Planned configurations (not supported at launch)

#### Partial home backup configuration (planned configuration)

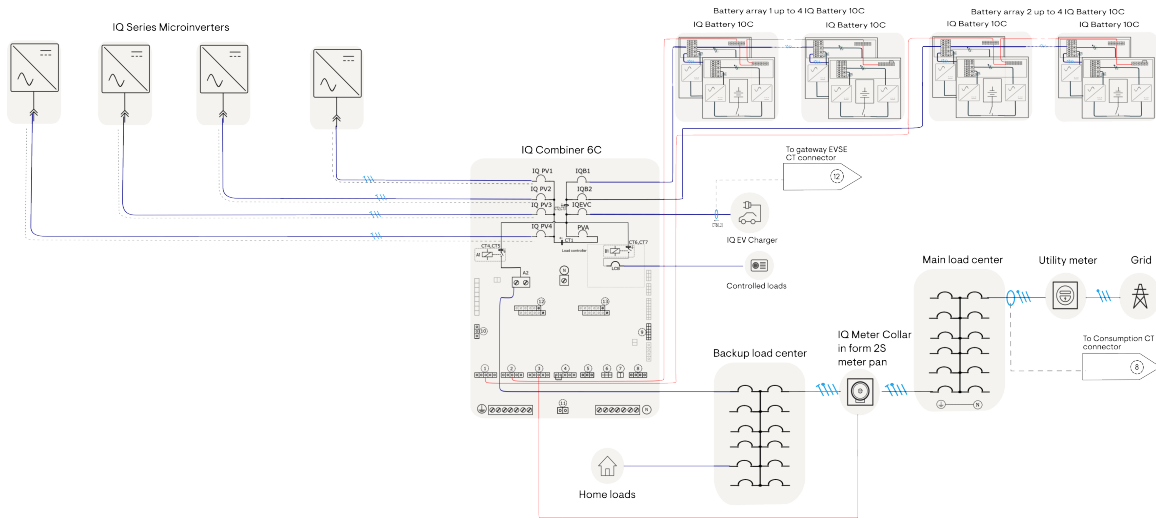



Figure 25: Partial home backup configuration

For notations, see [Legend](#) on page 46.

 **NOTE:** This configuration is not supported now. It will be enabled in the future through a software update and may require a software upgrade during commissioning.

- For full home energy monitoring, the external Consumption CT must be connected to the Consumption CT connector in the IQ Combiner 6C.
- The IQ Combiner 6C includes an integrated load controller with built-in CTs, which can connect legacy microinverters or third-party PV systems.

### 400 A supply #3

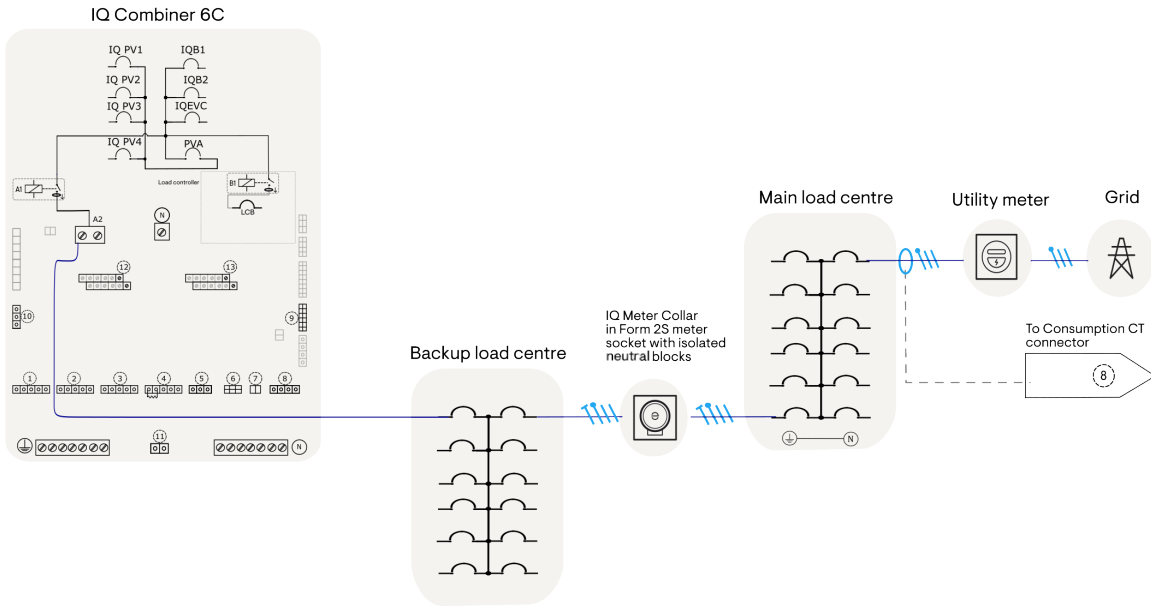

Figure 26: 400 A supply #3 - partial home backup with a single backup system

- A panel with an isolated neutral and a ground connection to the panel chassis/body is required. Alternatively, if the neutral is passed through (i.e., not terminated on the panel), the ground must still be connected to the chassis/body.

For notations, see [Legend](#) on page 46.

### Third-party PV with IQ Battery 10C (planned configuration)

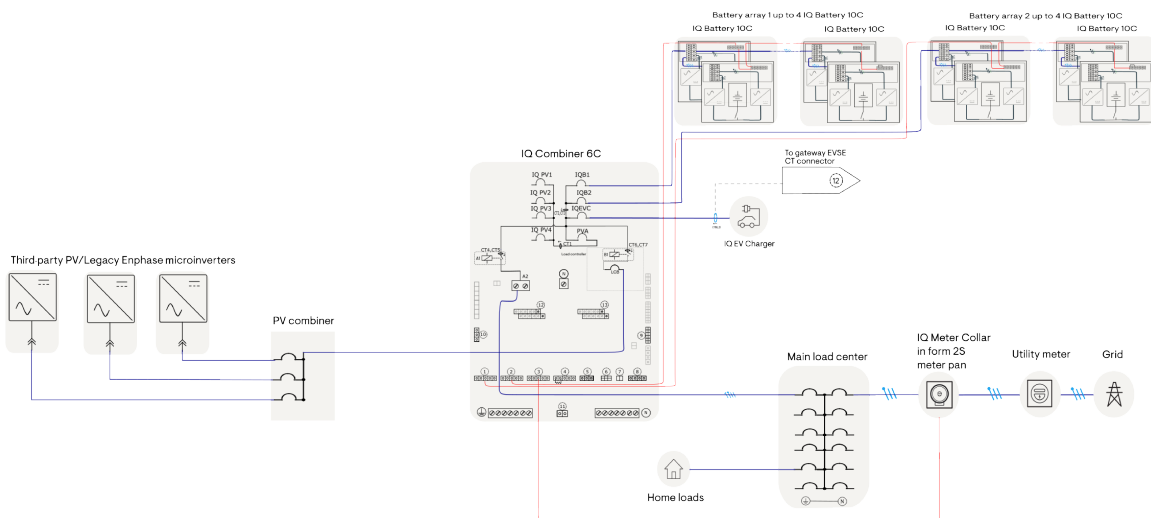

Figure 27: Third-party PV with IQ Battery 10C

For notations, see [Legend](#) on page 46.



**NOTE:** This configuration is not supported now. It will be enabled in the future through a software update and may require a software upgrade during commissioning.

- Maximum third-party PV/legacy PV allowed to be connected to the integrated load controller is  $100\% \times \text{Rated kVA}$  of the battery array.
- The system will disconnect the legacy Enphase/third-party PV systems when transitioning to off-grid operation.

## 20. Revision history

Revision	Date	Description
TEB-00282-4.0	February 2026	Updated partial home backup configuration images.
TEB-00282-3.0	January 2026	Updated breaker sizing information.
TEB-00282-2.0	November 2025	<ul style="list-style-type: none"> <li>Added NEM 2.0 expansion, third-party PV support, and IQ EV Charger integration.</li> <li>Updated rapid shutdown initiator and disconnects.</li> </ul>
TEB-00282-1.0	June 2025	Initial release.