



BRIGGS&STRATTON

SIMPLIPHI
SPHI-IN-6

6
kW



Installation Manual

SimpliPHI 6kW™ Hybrid Inverter

SimpliPHI Your Energy Security and Independence

and gain control of your own power.

SimpliPHI helps you manage your power as a personal resource. Anytime. Anywhere. SimpliPHI Energy Storage Systems (ESS) optimize the integration of any power generation source – solar, wind or generator – on or off grid and protects your home and critical business functions from power outages and rising utility costs with best-in-class batteries and inverters.

The SimpliPHI 6kW Hybrid Inverter is IP 65 indoor/outdoor rated with integrated MPPT that easily pairs with SimpliPHI battery storage solutions. Leverage savings with utility programs such as Net Metering, Demand Response and Time-of-Use configurations all while adding security to protect from planned and unplanned outages.

Table of Contents

<i>Specifications</i>	4
<i>Safety Information</i>	6
Important Safety Instructions.....	6
Warranty Statement.....	8
1.0 – Introduction	9
1.1 – Online Resources.....	9
1.2 – Technical Support.....	9
1.3 – Product Overview.....	9
2.0 – Safety	9
2.1 – General Safety Instructions.....	9
3.0 – Unpacking & Overview	10
3.1 – What Comes in the Box.....	10
4.0 – Installation	11
4.1 – Precautions.....	11
4.2 – Installation Tools & Materials.....	11
4.3 – Selecting a Mounting Location.....	11
4.4 – Mounting Hardware.....	11
4.4 – Sub-panel Installation & Wiring.....	12
4.5 – Conduit Installation.....	13
5.0 – Grid (Utility) Connection	14
5.1 – Preparation.....	14
5.2 – Connecting to the AC Utility.....	14
6.0 – Load (AC Output) Connection	15
6.1 – Preparation.....	15
6.2 – Connecting the Load Output Connection.....	16
7.0 – Battery Connection	16
7.1 – Operating Parameters for PHI Batteries Related to Cycle Life.....	17
8.0 – PV Module (DC) Connection	18
8.1 – SimpliPHI System Solar PV Array Sizing.....	19
8.2 – PV Connections.....	21
9.0 – Generator Connection	22
9.1 – Preparation.....	22
9.2 – Connecting to the Generator Input.....	23
9.3 – Dry Contact Signal.....	23
10.0 – Communication	25
10.1 – EnergyTrak Site Network and Internet Requirements.....	25
10.2 – Gateway Installation.....	26
10.3 – Pin Assignments.....	26
11.0 – Commissioning	26
12.0 – Programming and Operation	27
12.1 – Operation Modes.....	27
12.2 – Selecting Grid Profile.....	28
12.3 – AC Battery Charging Profiles.....	28
12.4 – Grid-Tie with Backup Setting Choices.....	29
12.5 – Grid-Tie.....	33

12.6 – Off-Grid.....	33
12.7– Interface.....	35
12.9– Touchable Function Keys.....	37
12.10– LCD Settings.....	38
13.0 – Wiring Diagrams.....	45
14.0 – Troubleshooting.....	47
14.1 Warning List.....	47
14.2 Fault Codes and Resolution.....	48

Specifications

Model Designation	SPHI-IN-6
Environmental Protection	IP65
Battery Input	
Nominal Battery Voltage (V)	40~62
Maximum Charging Voltage (V)	62 (Configurable)
Maximum Charging Current (A)	120
Maximum Discharging Current (A)	120
Charging Curve	3 Stages/Float
Charging Strategy for Li-Ion Battery	Self-adaption to BMS
Number of DC Connections	1
PV String Input	
Max. DC Input Power (W)	7,500
Max. DC Input Voltage (V)	600
MPPT Range (V)	120 ~ 550Vdc
Start-up Voltage (V)	160
Max. Input Current per MPPT (A) 15A x2	15/15
No. of MPPT Inputs	2
AC Output	
Nominal Apparent Power Output to Utility Grid (VA)	6,000
Maximum Supported Load- Continuous (W)	6,000
Nominal Output Voltage (V)	220/240V L1-L2, 110/120V L-N
Maximum Output Current (A)	40
Nominal Output Frequency (Hz)	50/60
O/P DC component (mA)	<100
Output Power Factor	0.9 leading to 0.9 lagging
Output THDi (@Nominal Output)	<3%
Switch Over Time (grid Down)	<8ms
AC Output (Back-up)	
Max. Output Apparent Power (VA)	6,000
Instantaneous Power-100ms (VA)	12,000
Surge Power-5 sec (VA)	9,000
Max. Output Active Power (W)	6,000
Nominal Output Voltage (V)	240VAC L1-L2 120VAC L-N 230VAC (50Hz)
Nominal Output Frequency (Hz)- Field Selectable	50/60 (±0.1Hz)
Maximum Input Current (A)	40

Output THDv (@Linear Load)	<3%
Output THDv (@PF 0.8 Non-linear Load)	<5%
Parallel function	Yes
Parallel units	9
AC Input	
Grid Input Current Maximum (A)	40
Generator Input Current Maximum (A)	40
Efficiency	
Max. Solar to Utility Efficiency	96.5%
Max. Battery to Load Efficiency	91.0%
Protection	
Anti-islanding Protection	Integrated
PV String Input Reverse Polarity Protection	Integrated
AFCI (Arc-Fault)	Integrated
Ground Fault Monitoring	Integrated
Insulation Resistor Detection	Integrated
Residual Current Monitoring Unit	Integrated
Output Over Current Protection	Integrated
Output Short Protection	Integrated
Output Over Voltage Protection	Integrated
General Data	
Operating Temperature Range: °F (°C)	-13 - 140 (-25~60)
Transformerless	Yes
Consumption Modes	UPS, Self-Consumption, TOU, Off-Grid Backup, Battery-less Operation (GT Only)
Relative Humidity	0~100%
Operating Altitude: feet (m)	<13,123' (<4,000m)
Cooling	External Force Convection
Noise (dB)	<50
User Interface- EnergyTrak	LCD / Phone Application (iOS & Android)
Communication with BMS	CANBUS
Communications between Inverters	CANBUS
Communication with Cloud- API with Grid Services	Wi-Fi (per Gateway)
Automated Generator Start	Included
Dimensions Inches: Height x Width x Depth (mm)	27.55" (700) x 20.28" (515) x 8.5" (216)
Weight	86 lbs. (39 kg)
Certifications / Standards	
Grid Regulation	UL 1741SA, Ed. 2, IEEE1547.1-2020,
Safety Regulation	IEC/EN 62109-1&2
EMC	EN 61000-6-2, EN 61000-6-3, EN 61000-6-1, EN 61000-6-4







Safety Information

Important Safety Instructions

SAVE THESE INSTRUCTIONS – This manual contains important instructions that must be read, understood and obeyed during installation of ESS and/or accessories.



WARNING! LOSS OF LIFE. THIS PRODUCT IS NOT INTENDED TO BE USED IN A CRITICAL LIFE SUPPORT APPLICATION. FAILURE TO ADHERE TO THIS WARNING COULD RESULT IN DEATH OR SERIOUS INJURY

	DANGER! INDICATES A HAZARDOUS SITUATION WHICH WILL RESULT IN DEATH OR SERIOUS INJURY. THESE CONDITIONS WILL RESULT IN THE TERMS OF THE WARRANTY BEING VIOLATED.
	WARNING! WARNINGS IDENTIFY CONDITIONS OR PRACTICES THAT COULD RESULT IN PERSONAL INJURY AND SEVERE DAMAGE TO THE SYSTEM. THESE CONDITIONS WILL RESULT IN THE TERMS OF THE WARRANTY BEING VIOLATED.
	CAUTION! CAUTIONS IDENTIFY CONDITIONS OR PRACTICES THAT COULD RESULT IN DAMAGE TO THE UNIT OR OTHER EQUIPMENT CONNECTED. THESE CONDITIONS CAN RESULT IN THE TERMS OF THE WARRANTY BEING VIOLATED.
	WARNING! INDICATES AN ELECTRIC SHOCK HAZARD.
	WARNING! INDICATES RISK OF FIRE.
	WARNING! INDICATES RISK OF HIGH TEMPERATURE.
	WARNING! INDICATES HEAVY OBJECT, RISK OF INJURY.



CAUTION! BEFORE INSTALLING AND USING THIS INVERTER, READ ALL INSTRUCTION MANUALS AND CAUTIONARY MARKINGS ON THE INVERTER AND ALL APPROPRIATE SECTIONS OF THIS GUIDE.



WARNING! NORMALLY GROUNDED CONDUCTORS MAY BE UNGROUNDED AND ENERGIZED WHEN A GROUND FAULT IS INDICATED.



WARNING! AUTHORIZED SERVICE PERSONNEL SHOULD REDUCE THE RISK OF ELECTRICAL SHOCK BY DISCONNECTING AC, DC, AND BATTERY POWER FROM THE INVERTER BEFORE ATTEMPTING ANY MAINTENANCE OR CLEANING OR WORKING ON ANY CIRCUITS CONNECTED TO THE INVERTER. TURNING OFF CONTROLS WILL NOT REDUCE THIS RISK.



WARNING! DO NOT DISASSEMBLE THIS INVERTER YOURSELF. IT CONTAINS NO USER-SERVICEABLE PARTS. ATTEMPT TO SERVICE THIS INVERTER YOURSELF MAY CAUSE A RISK OF ELECTRICAL SHOCK OR FIRE AND WILL VIOLATE THE TERMS OF THE WARRANTY FROM THE MANUFACTURER.



WARNING! TO AVOID A RISK OF FIRE AND ELECTRIC SHOCK, MAKE SURE THAT EXISTING WIRING IS IN GOOD CONDITION AND THAT THE WIRE IS NOT UNDERSIZED. DO NOT OPERATE THE INVERTER WITH DAMAGED OR SUBSTANDARD WIRING.



WARNING! UNDER HIGH TEMPERATURE ENVIRONMENT, THE COVER OF THIS INVERTER COULD BE HOT ENOUGH TO CAUSE SKIN BURNS IF ACCIDENTALLY TOUCHED. ENSURE THAT THE INVERTER IS ACCESSIBLE AND AWAY FROM HIGH TRAFFIC AREAS.



WARNING! THIS INVERTER SHOULD ONLY BE INSTALLED BY QUALIFIED PROFESSIONALS AS THERE IS RISK OF FIRE, ELECTRIC SHOCK, OR INJURY TO PERSONS.



CAUTION! TO REDUCE RISK OF FIRE HAZARD, DO NOT COVER OR OBSTRUCT THE COOLING FAN.



CAUTION! DO NOT OPERATE THE INVERTER IF IT HAS RECEIVED A SHARP BLOW, BEEN DROPPED, OR OTHERWISE DAMAGED IN ANY WAY. IF THE INVERTER IS DAMAGED, PLEASE CALL FOR AN RMA (RETURN MATERIAL AUTHORIZATION).



CAUTION! AC BREAKER, DC SWITCH AND BATTERY CIRCUIT BREAKER ARE USED AS DISCONNECT DEVICES AND THESE DISCONNECT DEVICES MUST BE EASILY ACCESSIBLE.

Warranty Statement

The following abbreviated guidelines do NOT encompass all SimpliPHI Inverter Warranty details. Failure to adhere to the Warranty and Installation Manual requirements will Violate the terms of the Warranty. Read the inverter's complete Warranty prior to installation and register the inverter or ESS system according to the form found at the bottom of the same web page address: <https://simpliphipower.com/wp-content/uploads/documentation/SimpliPHI-series/warranty>

Before using the inverter, please read all instructions and cautionary markings on the unit and this manual. Store the manual where it can be accessed easily. Only batteries listed on the SimpliPHI ESS Approved Battery list are within specification and covered under the SimpliPHI 6 kW Inverter Warranty.

This manual is for qualified personnel. The tasks described in this manual may be performed by qualified personnel only.

CAUTION: The following will result in damage to your SimpliPHI Inverter and will **Violate the terms of the Warranty.**

1. Incorrect Inverter wiring and/or installation
 - a. Verify polarity at all connections with a standard voltmeter (1) before energizing the system and (2) on batteries with threaded stud connections, before energizing the system. Reverse polarity at the SimpliPHI Battery terminals will Violate the terms of the Warranty and may permanently damage the SimpliPHI Inverter.

Pairing the Inverter with incompatible equipment. Only batteries listed on the SimpliPHI ESS Approved Battery list are within specification and covered under the SimpliPHI 6 kW Inverter Warranty.

2. Use of accessories not recommended or sold by the manufacturer may result in a risk of fire, electric shock, or injury to persons and will Violate the terms of the Warranty.
 - a. Contact ESS Technical Support at (805) 640-6700 x 1 regarding the compatibility of any equipment not explicitly listed in the 'SimpliPHI Integration Guides' section of the Product Documentation web page.

The SimpliPHI Inverter Warranty does NOT cover product damage caused by mishandling or improper use per the Installation Manual, Integration Guides and Warranty, exposure to liquids, impacts from falling objects or from being dropped, or attempts to repair the inverter by any party other than SimpliPhi. The complete list of Warranty Exclusions is included in the SimpliPHI Inverter Warranty document.



WARNING! RISK OF VOLTAGE BACKFEED! BEFORE WORKING ON THE SYSTEM:

- Isolate inverter and check for voltage between all terminals including ground.

1.0 – Introduction

1.1 – Online Resources

The Product Documentation section of SimpliPhi’s web site (<https://simpliphipower.com/product-documentation/>) includes Specification Sheets, Warranties, Installation & Operator’s Manuals, and Integration Guides for all SimpliPhi’s current and legacy products.

SimpliPhi’s YouTube channel (https://www.youtube.com/channel/UCcuCaLT_G3Hhumteh-pl5yg/videos) has instructional videos showing various steps of the battery installation process in detail.

1.2 – Technical Support

SimpliPhi Technical Support (805-640-6700 x 1, ESSTech@basco.com) is available to take any questions regarding this manual or general installation questions. For assistance with battery system commissioning, SimpliPhi asks that a commissioning call be **scheduled ahead of time** with Technical Support.

We encourage you or your installer to contact SimpliPhi with any questions. We are committed to working with you and your installation team to achieve a safe, reliable storage system that will provide years of maintenance-free service that is covered by our Warranty terms & conditions.

1.3 – Product Overview

The SimpliPhi Hybrid Inverter is designed to provide continuous power from PV solar arrays, batteries, generators and the grid. When MPPT input voltage of the solar array is within acceptable range (see specification for the details), the SimpliPhi Inverter is able to generate power to feed the grid (utility) and charge the batteries. The SimpliPhi Inverter is an all-in-one inverter that incorporates dual MPPT inputs for solar without the need for a charge controller, a battery charger, or integrated AC transfer switch. It is designed to integrate and optimize multiple AC generation sources such as the grid and generators for battery charging and powering loads.

See Figure 1 for a simple diagram of a typical solar system.

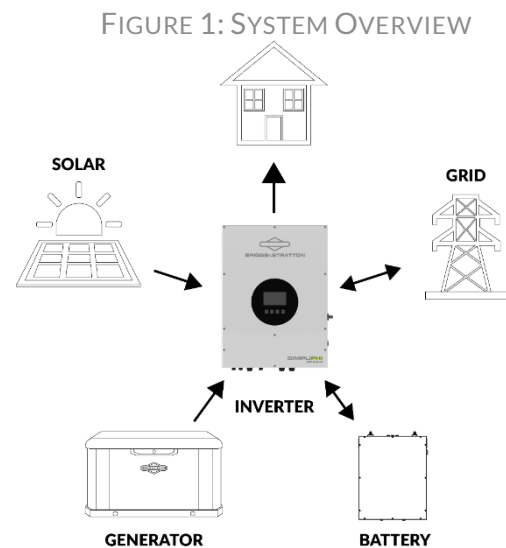

2.0 – Safety

For safety reasons, read all instructions and cautionary markings on the SimpliPhi Inverter, and all appropriate sections of this manual. Failure to follow instructions provided in the Installation Manual, Integration Guides and/or Warranty will Violate the terms of the Warranty.

2.1 – General Safety Instructions

- Do not operate if the SimpliPhi Inverter has been damaged in any way during shipping or otherwise.
- To reduce the chance of short-circuits, always use insulated tools when installing or working with SimpliPhi inverters or other electrical equipment.
- Remove personal metal items such as rings, bracelets, necklaces, and watches when working with SimpliPhi inverters and electrical equipment. Wear insulated gloves and rubber shoes.
- SimpliPhi Inverters pose some risk of shock or sparking during the installation and initial wiring and connection process. This is consistent with all other solar and battery-based system formats. To minimize the risk of shock or sparks during the installation and commissioning of the system, make sure the disconnect and load breakers are in the “OFF” position.

- To avoid a risk of fire and electric shock, make sure that existing system wiring is in good condition and that the wire is not undersized. Do not operate the SimpliPHI Inverter in conjunction with damaged or substandard wiring.
- Do not connect the positive or negative terminal of the solar panel to ground.

These safety precautions are in addition to the Warnings previously outlined on pages 6-8 of this Manual.

3.0 – Unpacking & Overview

3.1 – What Comes in the Box

Before installation, please inspect the unit. Be sure that nothing inside the package is damaged. You should have received the following items inside of package:

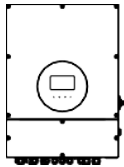

Inverter unit



Inverter Backplate

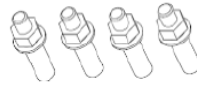

Additional Panel Screws

3.2 – Product Overview

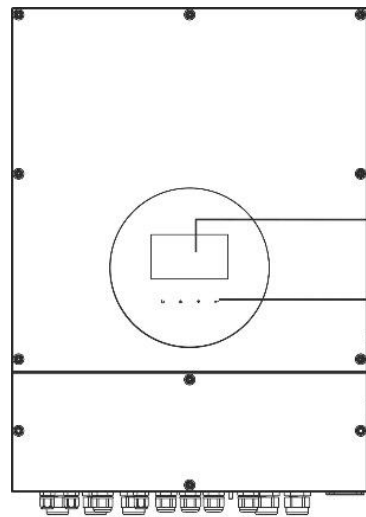

Front View

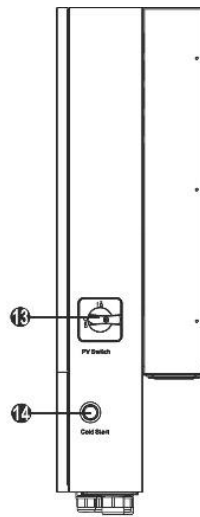

Right View

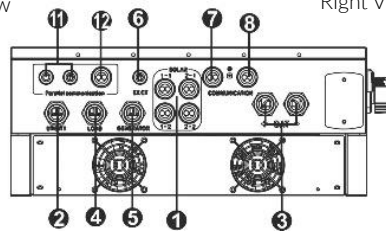

Bottom View

1. PV Connections
2. AC Grid Connections
3. Battery Connections
4. AC Output Connections
5. Generator Connections/Programmable Load Output/AC Coupling
6. External CT Port (reserved)
7. Dry Contact & USB Comm Port
8. BMS & RS-232 Comm Port
9. LCD Display Panel
10. Front Panel Controls
11. Current Sharing Port
12. Parallel Comm Port
13. PV Disconnect Switch
14. Battery Start Button (DC Start-Up)

4.0 – Installation

4.1 – Precautions

This hybrid inverter is designed for indoor or outdoor use (IP65). Make sure the installation site meets below conditions:

- Not in direct sunlight.
- Not in areas where highly flammable materials are stored.
- Not in a potential explosive area.
- Is only installed with batteries listed on the SimpliPHI ESS Approved Battery List.

4.2 – Installation Tools & Materials

- Digital Multi Meter
- AC/DC Clamp-On Current Meter
- Wire Stripper
- Impact Driver
- Masonry Bolts (if needed for mounting)
- 3mm Allen/Hex Key for removing front panel

4.3 – Selecting a Mounting Location

- Select a vertical wall with load-bearing capacity for installation. Inverter should be installed on concrete, brick, stucco or other non-flammable surfaces.
- Ambient temperature should be between -13°F~140° F to ensure optimal operation.
- For proper dissipation of heat, allow a clearance of no less than 8 in. to the sides, 18 in. above and below the unit. Please also allow minimum 3 ft. of clearance in front of the unit.

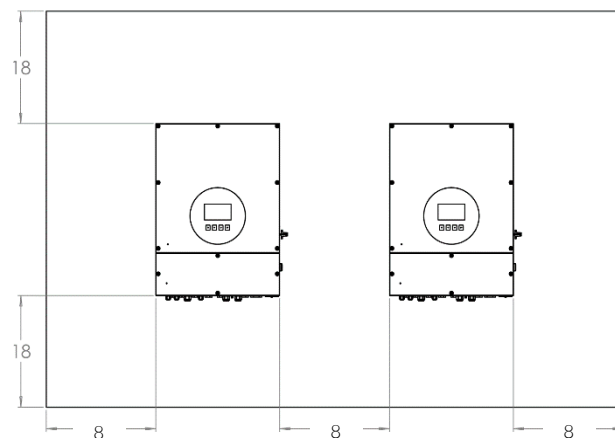

4.4 – Mounting Hardware



WARNING! REMEMBER THAT THIS INVERTER IS HEAVY! CARE SHOULD BE TAKEN WHEN LIFTING OUT OF PACKAGING AND DURING THE INSTALLATION PROCESS.



WARNING! FIRE HAZARD. SUITABLE FOR MOUNTING ON CONCRETE, BRICK, STUCCO OR OTHER NON-COMBUSTIBLE SURFACES ONLY.

The SimpliPHI Inverter wall bracket is designed to secure one SimpliPHI 6kW Inverter to a load bearing surface. The bracket should be mounted directly to the load bearing wall. Mounting brackets should be mounted into load bearing studs or solid materials with appropriate fasteners (mounting hardware not included). A qualified installer should be familiar with accomplishing this with the appropriate load bearing requirements. SimpliPhi Power is not liable for damage caused by the inappropriate installation of mounting of brackets.

Wall brackets are designed to hold one SimpliPHI Inverter with a weight of 86 pounds. Do not hang from or use a mounted inverter to support additional weight.

STEP 1: Secure the inverter wall bracket with at least 4 points of attachment. We strongly recommend installing the bracket across two 16 in. standard spaced studs. The mounting brackets accommodate these dimensions. To mount on a stud centered on the bracket please also use appropriate anchors, lags or toggles in the corners of the bracket with no less than 4 total points of attachment (see below). We recommend using 3/8-16 hardware to secure the bracket on the wall.

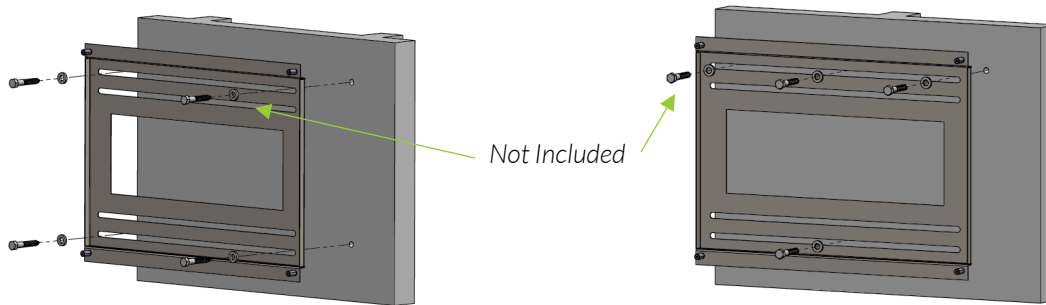

STEP 2: Make sure the Keyhole on the inverter aligns with the 3/8-16 stud on the wall mount bracket. Secure the Inverter on the wall mount bracket with 4 x 3/8-16 Serrated flange locknut (included with wall bracket).

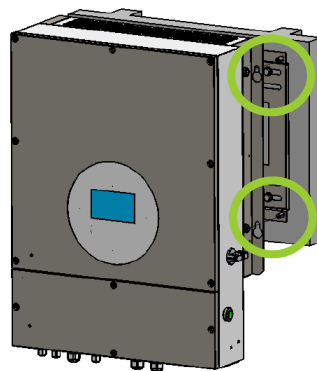

4.4 – Sub-panel Installation & Wiring

All SimpliPHI systems must incorporate either an Essential Loads sub-panel or a transfer switch kit. In the case of off-grid systems, all the home's loads are on the Essential Loads panel, thereby making the Essential Loads

panel the main house breaker panel. Any distance is permissible between the SimpliPHI system and the Essential Loads panel or transfer switch kit, provided wire sizing and voltage drop is calculated and charge in accordance with local codes.

Prior to the SimpliPHI system installation, determine which of the home’s circuits will be located either on the Essential Loads panel or transfer switch kit. Consider the following:

- A 50A double-pole breaker or OCPD is required to be installed within the essential load panel for the SimpliPHI inverter to be wired to.
 1. When grid-connected, the maximum continuous power the SimpliPHI Inverter can deliver to the Essential Loads panel is 25A at 240VAC (6 kWAC).
 2. When off-grid, the maximum power the SimpliPHI can deliver to the Essential Loads panel (also considered the main house breaker panel in an off-grid application) is 25A continuous at 240VAC (6 kWAC) and 50A peak at 240VAC (12 kWAC) for 100 milliseconds.

4.5 – Conduit Installation

Before making any wire connections install conduit on all input, output, solar and battery terminals. Conduit is not supplied with the inverter.

- The conduits, hubs and fittings must be rated for outdoor installation and meet code requirements per your AHJ.
- All hubs and fittings must comply with UL514B

NOTE: Clamps and fasteners for the attachment of conduit, electrical metallic tubing, armored cable, nonmetallic flexible tubing, nonmetallic-sheathed cable, service cable, or equivalent that are supplied as part of an enclosure must comply with the standard for Conduit, Tubing, and Cable Fittings, UL 514B.

STEP 1: Prepare one conduit pipe and two knockouts for each terminal.

Terminal Type	Trade Size Fitting	Outer Diameter
Utility, Load, Generator, Solar Input	¾"	1 1/8"
Battery Terminals	1"	1 3/8"

STEP 2: Install conduit pipe with two knockouts on the Grid/Utility terminal as shown below

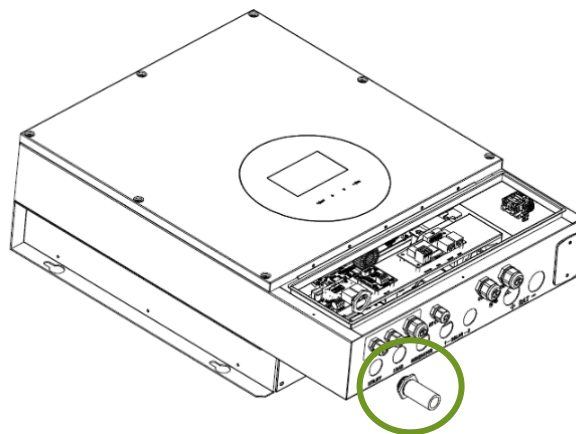

STEP 3: Repeat STEP 2 for other connections: generator, solar input and battery terminals separately.

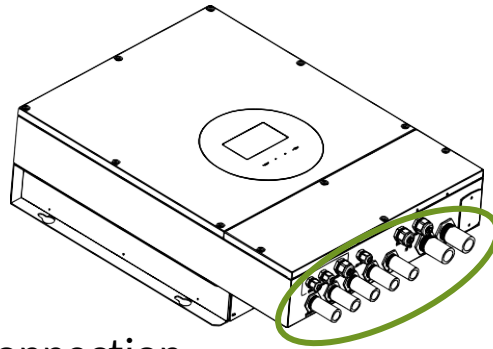

5.0 – Grid (Utility) Connection



WARNING! MAKE SURE THAT THE AC POWER SOURCE IS DISCONNECTED BEFORE ATTEMPTING TO INSTALL AND WIRE WITHIN THE INVERTER. NOT DOING SO WILL VIOLATE THE TERMS OF THE WARRANTY.

5.1 – Preparation

NOTE 1: The overvoltage category of the AC Input is III. This input should be connected to the power grid.

NOTE 2: Before connecting to grid, a properly sized and rated breaker between inverter and grid must be installed. This will ensure the inverter can be securely disconnected during maintenance and fully protected from over current.

WARNING: It is especially important for system safety and efficient operation to use appropriate cable for grid (utility) connection. To reduce risk of injury, please use the proper recommended cable size as below.

Table 5.0 – AC Wiring Sizing

Suggested Cable Requirement for AC Wire	
Nominal Grid Voltage	120/240 VAC
AWG	10 - 6

5.2 – Connecting to the AC Utility

Please follow below steps to implement AC input connection:

- Strip approximately ½” of the insulation on each of the conductors.
- Insert AC input wires according to polarities indicated on terminal block and tighten the terminal screws.
 1. GND (Ground) → Green
 2. N (Neutral) → White
 3. L2 → Red
 4. L1 → Black

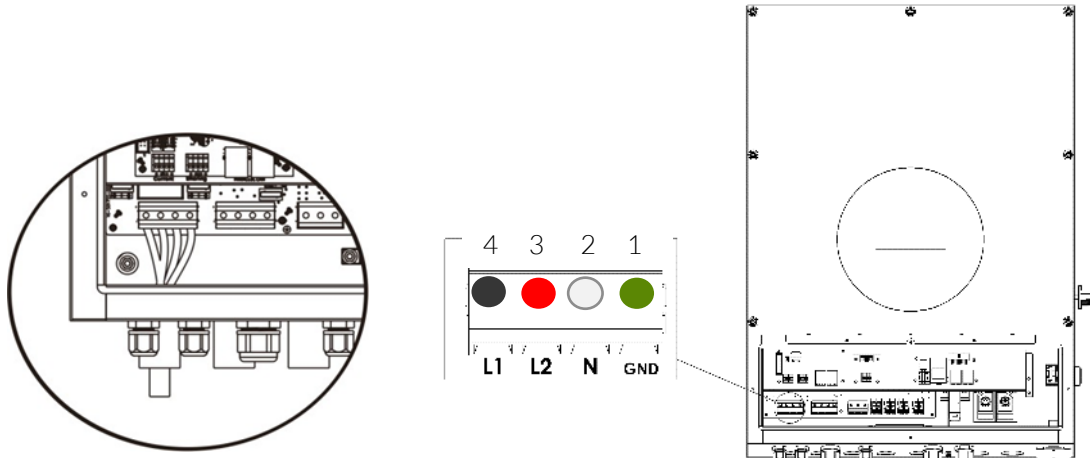

6.0 – Load (AC Output) Connection

6.1 – Preparation



WARNING! IT'S VERY IMPORTANT FOR SYSTEM SAFETY AND EFFICIENT OPERATION TO USE APPROPRIATELY SIZED WIRE FOR AC CONNECTION. NOT DOING SO WILL VIOLATE THE TERMS OF THE WARRANTY. DO NOT CONNECT THE UTILITY TO “AC OUTPUT CONNECTION (LOAD CONNECTOR).” ALL CONNECTIONS SHOULD BE IN ACCORDANCE WITH THE BELOW INSTRUCTIONS. NOT DOING SO WILL VIOLATE THE TERMS OF THE WARRANTY.



CAUTION! APPLIANCES SUCH AS AIR CONDITIONERS REQUIRE AT LEAST 2~3 MINUTES TO RESTART TO HAVE ENOUGH TIME TO BALANCE REFRIGERANT GAS INSIDE OF CIRCUITS. IF A POWER SHORTAGE OCCURS AND RECOVERS IN A SHORT TIME, IT MAY CAUSE DAMAGE TO YOUR CONNECTED APPLIANCE. TO PREVENT THIS KIND OF DAMAGE, PLEASE CHECK MANUFACTURER OF AIR CONDITIONER TO CONFIRM THAT IT IS EQUIPPED WITH TIME-DELAY FUNCTION BEFORE INSTALLATION. OTHERWISE, INVERTER/CHARGER WILL TRIGGER OVERLOAD FAULT AND CUT OFF OUTPUT TO PROTECT THE APPLIANCE. THIS MAY STILL RESULT IN DAMAGE TO THE AIR CONDITIONER OVER TIME.

To reduce risk of injury, please use the proper recommended cable size as listed below

Table 6.0 –Wiring Sizing

Suggested Cable Requirement for AC Wire	
Nominal Grid Voltage	120/240 VAC
AWG	10 - 6

6.2 – Connecting the Load Output Connection

Please follow below steps to implement AC load output connection:

- Strip approximately ½” of the insulation on each of the conductors.
- Insert AC output wires according to polarities indicated on terminal block and tighten the terminal screws.
 1. GND (Ground) → Green
 2. N (Neutral) → White
 3. L2 → Red
 4. L1 → Black

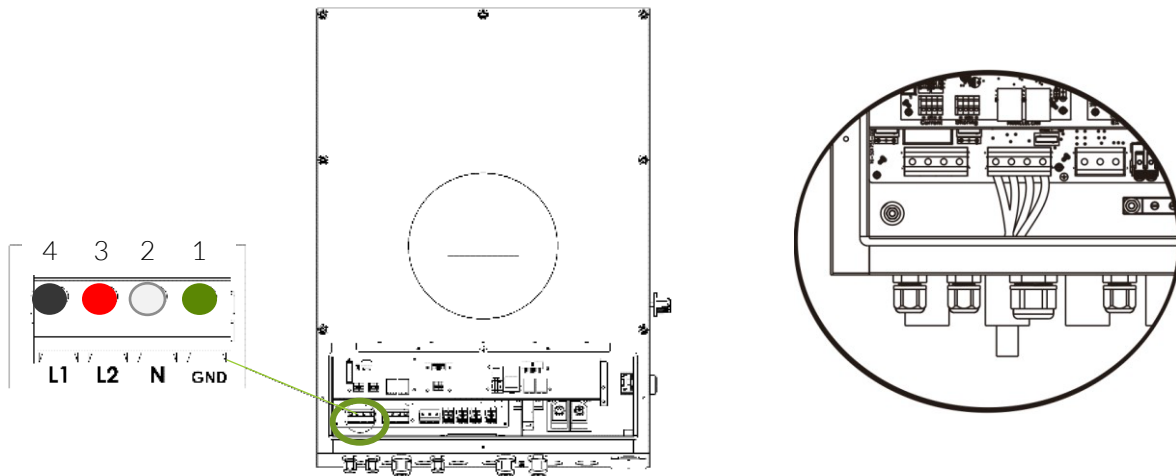

7.0 – Battery Connection

The SimpliPhi Inverter is designed for integration with all SimpliPhi battery products, including PHI, AmpliPhi, and SimpliPhi. Make sure that you follow PHI battery integration guides, settings and installation manuals for pairing with the SimpliPhi Inverter. If using a smaller (2) battery bank, adjustments to the charge/discharge settings will need to be made to avoid damage to the batteries.

Before connecting to batteries install **separately** a 60 VDC/200 ADC circuit breaker between the inverter and the batteries.

NOTE 1: Always check the maximum charging voltage and current allowable for the batteries when first installing the inverter. These settings should be appropriately programmed into the inverter prior to commissioning.

NOTE 2: Overvoltage category of the battery input is II.

CAUTION: Before connecting SimpliPhi batteries be sure that its breaker is in the OFF position.

Please follow below steps to implement battery connection:

Step 1: Check the nominal voltage of batteries. The nominal input voltage for inverter is 48 VDC.

Step 2: For each battery to inverter connection, it is required that you have one negative and one positive, each originating from opposite ends of each string of batteries.

Step 3: Remove insulation sleeve (10 mm) and insert bare cable end into a 1 1/32” width battery lug.

The cable size of each inverter is shown as below:

Table 7.0 –Wiring Sizing

Recommended Battery Cable and Terminal Size for Each Inverter			
Wire Size Minimum	Cable Lug Maximum	Dimensions	Torque Value
2/0	1 1/32" W	2"	3 ft lbs. / 36 in lbs.

Step 4: Insert battery wires according to polarities indicated on the terminal block and tighten the terminal screws to 36-inch pounds. Make sure polarity at both the battery and the inverter/charger is connected correctly. Use the provided bolts and washers to secure the battery cables.

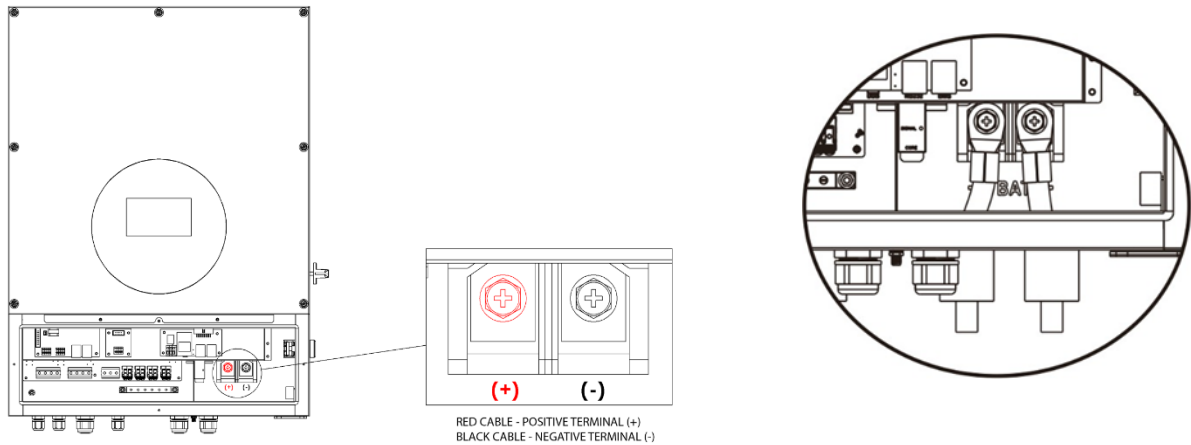

WARNING! WRONG CONNECTIONS WILL DAMAGE THE UNIT PERMANENTLY AND VIOLATE THE TERMS OF THE WARRANTY!

7.1 – Operating Parameters for PHI Batteries Related to Cycle Life

To maintain optimal PHI Battery health and longevity, adhere to the operating parameters outlined in Tables 7.1 and 7.2 below. This is specific to integration with the SimpliPHI 6 kW Inverter only.

Table 7.1 – Optimal Operation Parameters

Recommended Operating Conditions for 10 Year Warranty on PHI Batteries			
Equivalent to 80% Retained Capacity	10,000 Cycles	5,000 Cycles	3,500 Cycles
Depth of Discharge (DoD)	80%	90%	100%
Operating Temperature °F (°C)	32 to 120 (0 to 49)		
Low Battery Cut-Off Voltage (V)	50.2	49.6	48
Bulk Charge Voltage (V)	56	56	56

Table 7.2 – Operating Limitations

Notes/Operating Limitations for PHI Batteries	
Continuous Discharge (ADC)	37.5
Surge Discharge Rate (ADC) 10 minutes maximum	80
Continuous Charge Rate (ADC)	37.5

- Levels are typically @ 25°C and may need adjusting at temperature extremes.
- When performing rapid deep charge/discharge cycles, the PHI Battery should be allowed to “rest” 15 mins in between. Although the PHI battery charges to the voltages outlined above, the battery “rests” at approximately 53.3V. Refer to Table 7.3 below for a complete Battery Voltage versus State of Charge (SOC) gauge.

Table 7.3 – Optimal Operation Parameters

SOC	48V
100%	>52.5VDC
95%	51.7 VDC
90%	51.65 VDC
75%	51.4 VDC
50%	51.0 VDC
20%	50.2 VDC
10%	49.5 VDC
0%	48.0 VDC

8.0 – PV Module (DC) Connection

The SimpliPHI inverter has two MPPT inputs for different string lengths or orientations along with an integrated Rapid Shutdown Transmitter. This RSD transmitter is compatible with AP Smart rapid shutdown devices which can be mounted to the back of each solar module (sourced separately). This RSD transmitter in the inverter must be connected to an approved, remotely accessible E-Stop device that is readily available to emergency personnel.

Each of the MPPT input can handle a maximum combined STC Short Circuit Current (Isc) of 21A with a minimum input voltage of 160VDC and a maximum of 550VDC per string at expected operating conditions. Parallel strings of equal length can be combined per each MPPT input as long as they meet the minimum and maximum requirements stated in this manual. Each series string length should not exceed Voc of 600VDC at maximum expected operating conditions. Consult the solar module specification sheet for operating parameters to determine proper string sizing.

NOTE 1: Please use breakers that are rated for 1000VDC/20A

NOTE 2: Overvoltage category of the PV input is II.



CAUTION! BEFORE CONNECTING TO PV MODULES, PLEASE INSTALL **SEPARATELY** A RAPID SHUTDOWN OR EMERGENCY POWER OFF BUTTON AND TIE IN TO THE AP SMART MODULE RELAY IN THE INVERTER.



WARNING! EXCEEDING THE MAXIMUM INPUT VOLTAGE CAN DESTROY THE UNIT AND VIOLATE THE TERMS OF THE WARRANTY!! CHECK THE PV SYSTEM WIRING CONFIGURATION BEFORE MAKING YOUR FINAL CONNECTIONS.

8.1 - SimpliPHI System Solar PV Array Sizing

The SimpliPHI 6kW built-in MPPT input specifications are:

- Quantity of built-in MPPT inputs per SimpliPHI 6kW = 2
 - Quantity of PV ports per MPPT charge controller = 2
 - Total quantity of PV ports per SimpliPHI 6kW = 4
- MPPT charge controller starting voltage = 125V_{DC}, Initial Feed In Voltage: 160V_{DC}
- Maximum DC Voltage input per MPPT charge controller = 600V_{DC}
- MPPT charge controller voltage range = 120 - 550V_{DC}
- Maximum I_{sc} current input per MPPT charge controller = 21A
- Maximum operating current input per MPPT charge controller = 15A
- Maximum battery charging current per SimpliPHI 6kW = 120A



WARNING! IT IS CRITICAL THAT THE SOLAR PV STRING'S VOLTAGE DOES NOT EXCEED 600 V_{OC}; VOLTAGE GREATER THAN 600 V_{DC} FOR LONG PERIODS OF TIME WILL DAMAGE THE SIMPLIPHI EQUIPMENT AND VIOLATE THE TERMS OF THE WARRANTY.

To properly configure solar PV modules to the SimpliPhi's built-in charge controllers:

1. Due to the charge controller's starting voltage of 160V_{DC}, calculate the minimum number of solar panel modules needed to meet this target voltage at the module's maximum power voltage (V_{MP}).

In this example, consider the [Canadian Solar KuPower CS3K-300](#) solar PV module with a V_{MP} of 32.5V at Standard Test Conditions (STC).

- **Five** modules in series are required to meet the minimum MPPT tracking voltage requirement: 160V ÷ 32.5V = 4.9 (round up to the next whole number).
2. The MPPT Input maximum DC voltage is 550V_{DC}. Temperature affects the solar PV module's voltage output: voltage increases as temperature decreases. To calculate the maximum number of solar panel modules in series per PV string, consider the module's open circuit voltage (V_{OC}) rating, temperature coefficient and lowest expected temperature at the installation site.

In this example, the KuPower 300W module has a V_{OC} of 39.3V at STC, a STC temperature of 25°C, and a V_{OC} temperature coefficient of -0.29%/°C.

To calculate the solar module's V_{OC} in an extreme low temperature condition of, say, -10°C:

$$V_{OC-MAX} = V_{OC} \times \{1 + [(Temp_{LOW} - Temp_{STC}) \times (V_{OC}TempCoefficient)]\}$$

$$V_{OC-MAX} = 39.3V_{OC} \times \{1 + [(-10°C - 25°C) \times (-0.29\%/°C)]\}$$

Remember to convert the percentage value given as the V_{OC} temperature coefficient to a decimal.

$$V_{OC-MAX} = 39.3V \times \{1 + [(-10°C - 25°C) \times (-0.0029/°C)]\}$$

$$V_{OC-MAX} = 39.3V \times \left\{ 1 + \left[(-35^{\circ}C) \times \left(\frac{-0.0029}{^{\circ}C} \right) \right] \right\}$$

$$V_{OC-MAX} = 39.3V \times \{1 + [(0.1015)]\}$$

$$V_{OC-MAX} = 39.3V \times 1.1015$$

$$V_{OC-MAX} = \mathbf{43.3V}$$

- Twelve modules are the maximum allowable number of modules in series to prevent the solar PV string from exceeding the charge controller's maximum voltage input rating even in the coldest weather conditions at the installation site: $550V \div 43.3V = 12.7$ (round down to the next whole number).
 - Twelve modules in series at the KuPower 300W module's V_{MP} rating of 32.5V at STC also equates to 390V, well within the charge controller's 120-550V_{DC} maximum power point tracking range.
- 3. The MPPT input maximum short circuit current (I_{sc}) is **21Adc**. Temperature also slightly affects the solar PV module's current output: current increases as temperature increases. However, because the temperature coefficient is negligible, it is acceptable to simply use the module's I_{sc} rating at STC for the following calculation.

To calculate the maximum number of solar PV strings per MPPT input in this example, consider the KuPower 300W module's I_{sc} at STC: **9.82A**.

- According to this calculation, **two** solar PV strings is the maximum allowable number of strings per MPPT input: $21A \div 9.82A = 2.13$ (round down to the next whole number).
 - Although the SimpliPHI 6kW contains only two solar PV string inputs, more than two strings in parallel can be wired to the SimpliPHI 6K. If more than two strings are connected in parallel to a single MPPT input, each string must be fused.
 - Two solar PV strings in parallel at the KuPower 300W module's I_{MP} rating of 9.24A equates to **18.48A** at STC, well within the limits of the MPPT input's short circuit current input limit of 21A.

Based on calculations #2 and #3 above, a maximum of two parallel strings of twelve KuPower 300W modules in series can be wired to each of the SimpliPHI 6kW's MPPT inputs.

Considering the above calculations, the optimal solar module configuration in this example is wiring a maximum of **two parallel strings of twelve** KuPower 300W modules in series to each of the two SimpliPHI 6kW's two charge controllers, for a total of 24 modules paired with the SimpliPHI 6kW.



WARNING: BECAUSE THE SIMPLIPHI INVERTER IS NON-ISOLATED ONLY TWO TYPES OF PV MODULES ARE ACCEPTABLE: CLASS A-RATED MONO-CRYSTALLINE AND POLY-CRYSTALLINE MODULES.

To avoid any malfunction, do not connect PV modules with the possibility of current leakage to the inverter. For example, grounded PV modules will cause leakage current to the inverter.

CAUTION: It is recommended to have a PV junction box with surge protection. Not having appropriate surge protection with lightning arrestors can cause high voltage to enter the inverter and damage the electronics. Damage caused by high voltage input will Violate the terms of the Warranty.

8.2 - PV Connections

Step 1: Check the input voltage of PV array module strings with a multi-meter. The acceptable input voltage of the inverter is 120VDC - 600VDC and current should not exceed 15A (or 21A I_{sc})

Step 2: Turn your PV circuit breaker, RSD device and PV disconnect switch to the OFF positions.

Step 3: Strip approximately ½” of the insulation on each of the conductors.

Step 4: Check for correct polarity on the connection cable from PV modules and PV input connectors. Then, connect the positive pole (+) of connection cable to the positive pole (+) of PV input connector. Connect the negative pole (-) of the connection cable to the negative pole (-) of the PV input connector.

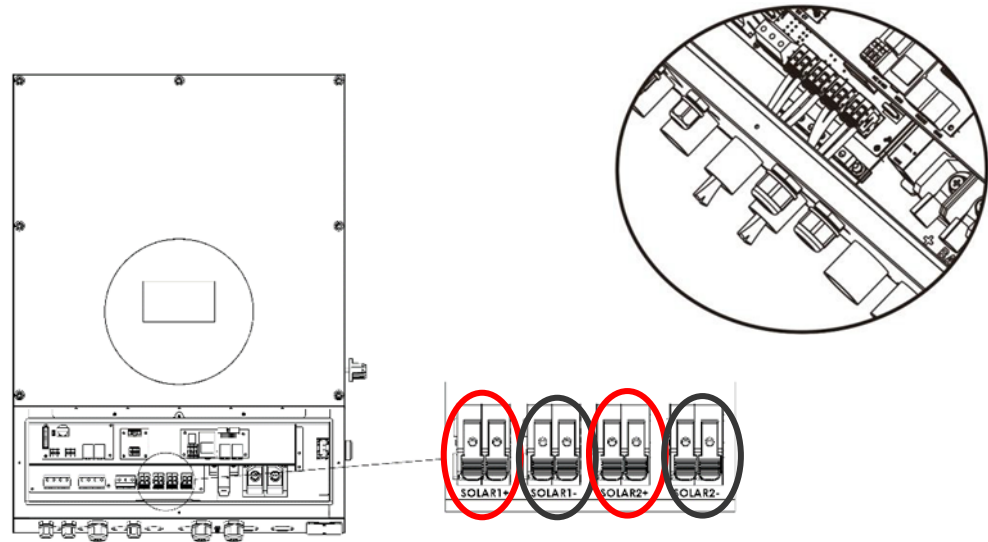

Step 5: Tie in your EPO or RSD button to the RSD terminals. Once PV is connected and all polarity verified, turn the PV Disconnect switch on the side of the inverter to the “ON” position. Once the inverter is up and running test your rapid shutdown procedure and verify it is functioning properly.



WARNING! IT IS VERY IMPORTANT FOR SYSTEM SAFETY AND EFFICIENT OPERATION TO USE APPROPRIATE CABLE FOR PV MODULE CONNECTION. TO REDUCE RISK OF INJURY USE #12AWG OR #10AWG WIRE FOR PV CONNECTIONS.



WARNING! NEVER DIRECTLY TOUCH TERMINALS OF THE INVERTER. IT CAN CAUSE LETHAL ELECTRIC SHOCK.



CAUTION! DO NOT TOUCH THE INVERTER COMPONENTS IF THE PV SWITCH IS IN THE ON POSITION. WHEN PV MODULES ARE EXPOSED TO SUNLIGHT, THEY MAY BE GENERATING DC VOLTAGE.

9.0 – Generator Connection

The SimpliPHI Inverter has a built-in Automatic Generator Start (AGS) relay that will enable you to connect a two-wire start generator to the inverter. Based on battery voltage settings within the inverter, you can trigger the generator to automatically come on to provide battery charging and/or support loads when the batteries reach a low voltage setpoint or SOC.

It is recommended to set the AGS voltage or low SOC trigger setting higher than the SimpliPHI Inverter Low Battery Cut Out voltage or SOC level (see settings).

Generators wired to the SimpliPHI Inverter must be rated at 240VAC. Generators can either be wired to the SimpliPHI Generator Input Port or to the SimpliPHI Bi-directional Grid Port. **In grid-connected systems, generators cannot be wired to the Grid Port.** However, the SimpliPHI Generator Input Port may need to be utilized for purposes other than the generator's connection. AC Coupled systems can be wired to the SimpliPHI Generator Input Port.

For AC Coupled systems using the Generator Input Port, an external ATS must be incorporated into the system for generator support.

Please consult your generator installation and operation manual to determine if it requires a normally open (NO) or normally closed (NC) operation.

There are three functions with this port (Setting 39 on display):

- Allows generator input as power source.
- Allows second AC output connection for AC Coupling.
- Disabled. Default is set to OFF.

9.1 – Preparation

NOTE 1: Refer to the manual of your generator to determine overcurrent protection, wire sizing and appropriate means of disconnect. The overvoltage category of the AC Input is III.

NOTE 2: Before connecting to grid, a separate AC breaker between the inverter and grid must be installed. This will ensure the inverter can be securely disconnected during maintenance and fully protected from over current. The recommended sizing of the AC breaker is 40A/300V.



WARNING! IT'S VERY IMPORTANT FOR SYSTEM SAFETY AND EFFICIENT OPERATION TO USE APPROPRIATE CABLE FOR GENERATOR CONNECTION. TO REDUCE RISK OF INJURY, PLEASE USE THE PROPER RECOMMENDED CABLE SIZE AS BELOW.

Table 9.0 –Wiring Sizing

Suggested Generator Cabling Requirements	
Nominal Grid Voltage	Cable AWG
120/240 VAC	10 - 6

9.2 – Connecting to the Generator Input



WARNING! BE SURE THAT THE GENERATOR POWER SOURCE IS DISCONNECTED BEFORE ATTEMPTING TO CONNECT THE UNIT.

Please follow below steps to implement generator input connection:

- Before making generator input connection, be sure to open DC overcurrent protector or disconnect first.
- Verify voltage on GEN terminals with a voltmeter prior to making connections.
- Strip approximately ½” of the insulation on each of the conductors.
- Insert AC input wires according to polarities indicated on terminal block and tighten the terminal screws.
 1. GND (Ground) → Green- to grounding bar
 2. N (Neutral) → White
 3. L2 → Red
 4. L1 → Black

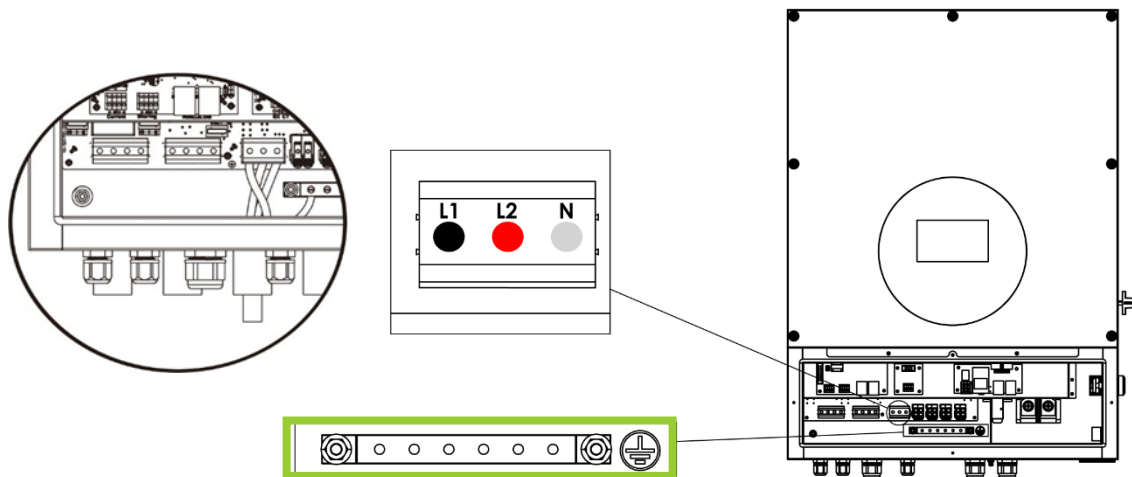

9.3 – Dry Contact Signal

There is one dry contact available within the integrated distribution panel. This dry contact is utilized for the automatic generator start (AGS) functionality.

Table 9.1: Electric Parameters

Parameter	Symbol	Max	Unit
Relay DC Voltage	VDC	30	V
Relay DC Current	IDC	1	A

NOTE: The application of the dry contact should not exceed the electric parameters shown above. Exceeding these limits will damage the relay and Violate the terms of the Warranty.

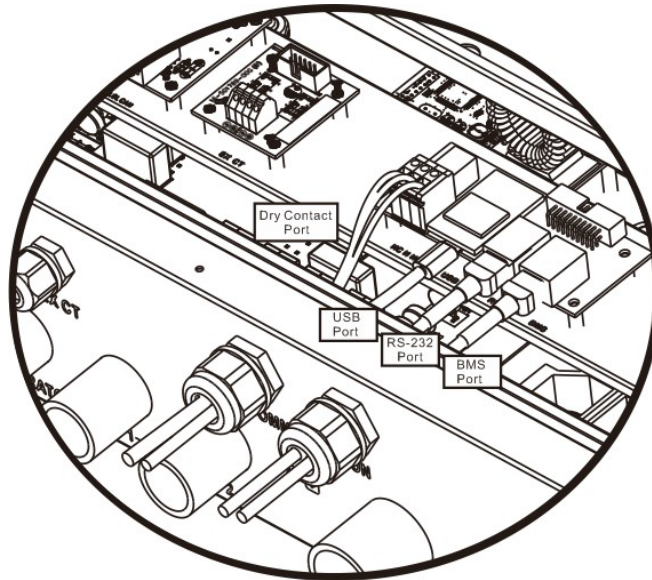
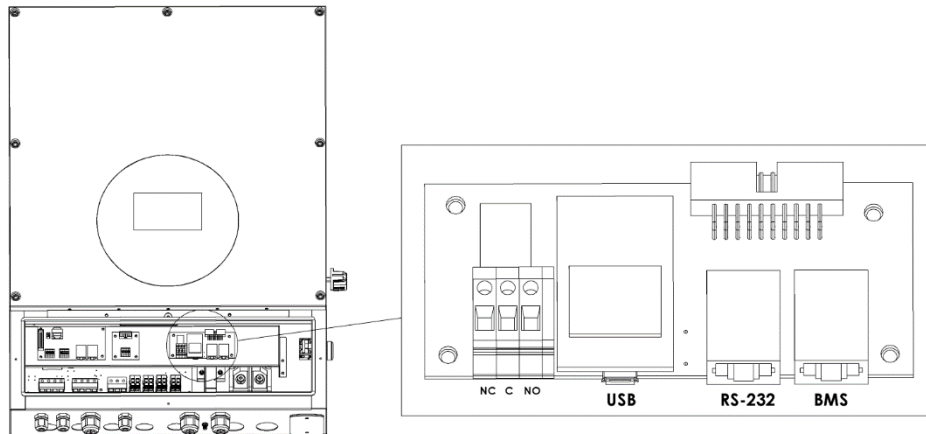

Table 9.2: Function Descriptions

Unit Status	Condition	Dry Contact Port Unit	
		NO & C	NC & C
Power Off	Unit is off and no output is powered	Open	Closed
Power On	Battery Voltage is lower than setting for gen start voltage when grid is available	Closed	Open
	Battery Voltage is lower than setting for gen start voltage when Grid is NOT available	Closed	Open
	Battery Voltage is higher than the below two setting values: 1. Battery re-charge voltage when grid is available 2. Battery discharge voltage when grid is unavailable	Open	Closed



10.0 – Communication



The inverter is equipped with several communication ports for alternative communication interfaces in order to communicate with a PC with corresponding software. Follow below procedure to connect communication wiring and install the software.

10.1 – EnergyTrak Site Network and Internet Requirements

Refer to the full EnergyTrak Installation Manual for detailed instructions on set-up and programming available for download on our website: <https://simpliphipower.com/wp-content/uploads/re/products/ess-energytrak-control-system/installation/energytrak-control-system-installation-manual.pdf>

System Requirements

For proper functionality, two or more PI, AmpliPHI or SimpliPHI batteries must be installed to allow for over-the-air (OTA) firmware updates to the inverter.

General Network & Internet Requirements

At the site of installation, the system owner is responsible for providing:

- A stable local area network with
- A connection to the Internet and
- An Internet connection to the EnergyTrak Gateway.

An internet connection is REQUIRED for using EnergyTrak with the SimpliPHI ESS, and the warranty terms of EnergyTrak and SimpliPHI ESS are impacted by the maintenance of a consistent Internet connection to the system.

Hardwired Network Requirements (recommended)

A hardwired network connection to the EnergyTrak Gateway requires:

- Available Ethernet port for the Gateway to connect to the local area network
- Cat5e or Cat6 ethernet cable with RJ45 connectors on each end
- Ethernet cable cannot be longer than 131 feet (40 meters)

Wi-Fi Network Requirements: Refer to the EnergyTrak manual for more information.



CAUTION! BRIGGS & STRATTON DOES NOT RECOMMEND OR SUPPORT THE USE OF A WIRELESS CONNECTION. AN UNRELIABLE WIRELESS NETWORK CONNECTION CAN DISRUPT TIMELY FIRMWARE UPDATES, WHICH COULD LEAD TO SYSTEM FAILURES AND LOSS OF WARRANTY COVERAGE.

10.2 – Gateway Installation

Refer to the full EnergyTrak Installation Manual for detailed instructions and diagrams on set-up and programming.

1. Connect the Gateway to the SimpliPHI 6kW Inverter with the provided CAT5 cable.
2. If using a hardwired network connection (recommended), connect the Gateway to the site's local network using an Ethernet cable.
3. Connect the Gateway Power Supply to the SimpliPHI 6kW Inverter with the provided cable.

10.3 – Pin Assignments

Table 10.0: Pin Assignment for RS-232 Communications Port

	Definition
PIN 1	RS232TX
PIN 2	RS232RX
PIN 3	NC
PIN 4	8~12V
PIN 5	NC
PIN 6	NC
PIN 7	NC
PIN 8	GND

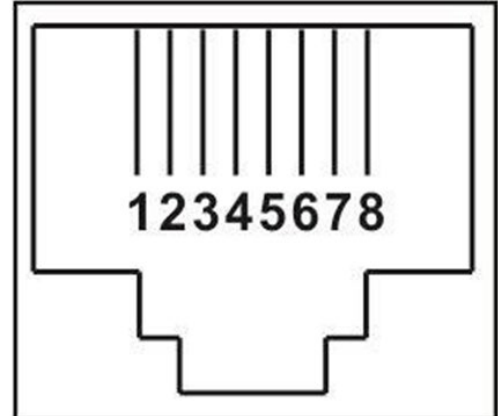

Table 10.1: Pin Assignment for BMS Communications Port

	Definition
PIN 1	RS232TX
PIN 2	RS232RX
PIN 3	NC
PIN 4	8~12V
PIN 5	NC
PIN 6	NC
PIN 7	NC
PIN 8	GND

11.0 -Commissioning

Prior to commissioning equipment, check the following requirements and follow proper electrical procedures:

STEP 1: Confirm All Connections and Voltage

- Ensure that all installation processes and procedures are complete and followed in previous sections.
- Not following installation instructions will Violate the terms of the Warranty.
- Verify that the Open Circuit PV Voltage is within the specified range. (Refer to Section 8)
- Verify the Open Circuit Utility Voltage and this value matches the expected value from the utility company.
- Verify the Open Circuit DC Battery Voltage (if installing with batteries).
- Check that all AC and DC wiring is properly installed and connected, and make sure all connections are secure.

STEP 2: Supplying DC and AC Power

- Switch battery breakers to the ON position
- Turn PV disconnect switch to the ON position
- Supply AC Grid Power

STEP 3: Powering on the Inverter

- If installing batteries, press the green “BATT START” button on the side of the unit. If installing without batteries, the “BATT START” step can be skipped.
- After the short countdown on the display (4 seconds), press the “ON” button on the front display for 2 seconds.
- When Grid power has been supplied the inverter will go through a ~60 second Grid Monitoring process and once verified you will hear an audible click from the internal relays in the inverter.
- The inverter will now be supplying power to the LOAD output terminals.
 - If LCD display lights up to show the current inverter status, commissioning has been successful.
 - After pressing “ON” button for 1 second when the utility is detected, the inverter will start to supply power to the loads. If there is no existing utility, simply press the “ON” button for 3 seconds. This will enable the inverter to start supplying power to the loads.
 - If a warning/fault indicator appears on the LCD, an error has occurred. Please contact tech support (ESSTech@basco.com) or review the troubleshooting supplement on our website.

STEP 4: Programming

- Configure the inverter via one of the following options:
 - Connect to the SimpliPHI Gateway and commission via a mobile device (Section 10.1)
 - Inverter Front Face Display (Section 12)

12.0 -Programming and Operation

This section outlines the steps to program the inverter manually from the display on the front of the unit. You should follow the proper commissioning steps as outlined in Section 11 of this manual prior to programming the unit. **DO NOT** operate the system without proper programming, doing so will **Violate the terms of the Warranty**.

12.1 – Operation Modes

There are three operational modes: Grid-Tie with Backup, Grid-Tie, or Off-Grid

- Grid-Tie with Backup: PV power can feed back to the grid, provide power to the loads and charge the batteries. There are four choices available in this mode:

- Grid-Tie with Backup 1 (I)
- Grid-Tie with Backup 2 (II)
- Grid-Tie with Backup 3 (III)
- Grid-Tie with Backup 4 (IV): Use this mode specifically for Time of Use (TOU). The inverter is only operated between two working logics based on defined peak start and end times to optimize energy usage.

In the Grid-Tie with Backup mode, users can configure the PV power supply priority, charging source priority, and load supply source priority. See additional settings in Section 12.3.

- Grid-Tie: PV power can only feedback to grid. Battery charging is not active.
- Off-Grid: PV power only provides power to the loads and charges battery. PV to the grid is deactivated.
 - Off-Grid (I)
 - Off-Grid (II)
 - Off-Grid (III)

12.2 – Selecting Grid Profile

Please select the grid standard applicable to your region. The default setting for the inverter is North American standard IEEE1547.2.

Nominal Output Voltage: 120/240V

Output Frequency: 60Hz



WARNING! SELECTING THE WRONG SETTING CAN CAUSE DAMAGE TO THE INVERTER AND WILL VIOLATE THE TERMS OF THE WARRANTY.

12.3 – AC Battery Charging Profiles

Based on the operations chosen in Section 12.2, the set-up window may show different operations. These modes can be established in display programming (Steps 13-26)

Allow AC Charging Duration: This establishes a period of time to allow AC (Grid) to charge the batteries.

- If duration is set to 0:00 – 0:00, a time limitation for AC to charge the battery has not been established.

AC Output ON/OFF Timer: This sets up the on/off time for AC Output of the inverter.

- If setting is 0:00 – 0:00 the setting is disabled.

Allow to Charge Battery: This option is automatically determined by setting in “Charging source”. You cannot modify the setting from this screen.

- When “NONE” is selected in the charging source section, this option becomes unchecked as grey text.

Allow AC to Charge Battery: This option is automatically determined by setting in “Charging source”. You cannot modify the setting from this screen.

- When “Grid and PV” or “Grid or PV” is selected in charging source section, this option is by default selected.
- Under Grid-Tie mode, this option is invalid.

Allow to Feed-In to the Grid: This option is only valid under Grid-Tie and Grid-Tie with Backup modes.

- This setting allows you to select or deselect the inverters capabilities to feed back into the grid. Some net-metering agreements and utilities will not allow power to be fed back into the grid.

Allow Battery to Discharge when PV is Available: This option is automatically determined by setting in “Load Supply Source (PV is available)”.

- When “Battery” is set as a higher priority than “Grid” in “Load Supply Source (PV is available)”, this option is by default selected.
- Under Grid-Tie, this option is invalid.

Allow Battery to Discharge when PV is Unavailable: This option is automatically determined by setting in “Load Supply Source (PV is unavailable)”.

- When “Battery” is higher priority than “Grid” in “Load Supply Source (PV is unavailable)”, this option is by default selected.
- Under Grid-Tie mode, this option is invalid.

12.4 – Grid-Tie with Backup Setting Choices

Option 1: Grid-Tie with Backup (I)

PV Energy Supply Priority Setting: PV will supply energy in the following order:

1. Battery
2. Loads
3. Grid

Charging Source:

1. PV and Grid (Default): Allows charging of the battery from PV first. If PV source is not sufficient to charge the battery, the grid will charge the battery also.
2. PV Only: Only allows charging of the battery from PV array. Grid will not be used to charge the battery.
3. None: No battery charging will be provided from PV or Grid.

Load Supply Source (PV is Available): Loads will be supplied in the following order:

1. PV
 2. Grid
 3. Battery
- If battery is not fully charged, PV power will charge the battery first. Remaining PV power generation will supply loads. If it is not sufficient, grid will provide power to the loads. If grid is not available at the same time, battery will provide back-up to the loads.

Load Supply Source (PV is unavailable): Loads will be supplied in the following order:

1. 1st Grid then 2nd Battery (Default): Grid will provide power to the loads first, if grid is not available

battery will supply power to loads as back-up.

2. 1st Battery then 2nd Grid: Battery will provide power to the loads first. If battery voltage is low, the grid will power the loads.

NOTE: This option becomes ineffective during AC charging time, and the priority will default to Grid 1st and Battery 2nd order. **Overriding this setting will cause damage to the batteries and will Violate the terms of the Warranty.**

Option 2: Grid-Tie with Backup (II)

PV Energy Supply Priority Setting: PV will supply energy in the following order:

1. Loads
2. Battery
3. Grid

PV will provide power to the loads first, then it will charge the battery. If there is more production than loads being supported and battery to be charged, it will feed remaining power into the grid.

Charging Source:

1. PV and Grid (Default): Allows charging of battery from PV first. If PV source is not sufficient to charge the battery, the grid will charge the battery also.
2. PV Only: Only allows charging of battery from PV array. Grid will not be used to charge the battery.
3. None: No battery charging will be provided from PV or Grid.

Load Supply Source (PV is Available): Loads will be supplied in one of the following options:

Option 1:

1. PV
2. Battery
3. Grid

PV will provide power to the loads first. If PV is not sufficient to support the loads, battery will provide additional power to the loads. When battery reaches LBCO or is not available, grid will power the loads.

Option 2:

1. PV
2. Grid
3. Battery

PV will provide power to the loads first. If PV is not sufficient to support the loads, grid will provide additional power to the loads. If the grid is not available, battery will provide backup power to the loads.

Load Supply Source (PV is unavailable): Loads will be supplied in one of the following options:

1. 1st Grid then 2nd Battery (Default): Grid will provide power to the loads first, if grid is not available battery will supply power to loads as back-up.
2. 1st Battery then 2nd Grid: Battery will provide power to the loads first. If battery voltage is low, the grid will power the loads.

NOTE: This option becomes ineffective during AC charging time, and the priority will default to Grid 1st and Battery 2nd order. **Overriding this setting will cause damage to the batteries and will Violate the terms of the Warranty.**

Option 3: Grid-Tie with Backup (III)

PV Energy Supply Priority Setting: PV will supply energy in the following order:

1. Loads
2. Grid
3. Battery

PV will provide power to the loads first, if there is excess PV generation, it will feed-in to the grid. If feed-in power reaches max feed-in power setting, the remaining generation will charge the battery.

NOTE: The Max Feed-In Grid Power Setting is available in parameter settings within the software and should be set based on your utility interconnection agreement.

Charging Source:

1. PV and Grid (Default): Allows charging of battery from PV first. If PV source is not sufficient to charge the battery, the grid will charge the battery also.
2. PV Only: Only allows charging of battery from PV array. Grid will not be used to charge the battery.
3. None: No battery charging will be provided from PV or Grid.

Load Supply Source (PV is Available): Loads will be supplied in one of the following options:

Option 1:

1. PV
2. Battery
3. Grid

PV will provide power to the loads first. If PV is not sufficient to support the loads, battery will provide additional power to the loads. When battery reached LBCO or is not available, grid will power the loads.

Option 2:

1. PV
2. Grid
3. Battery

PV will provide power to the loads first. If PV is not sufficient to support the loads, grid will provide additional power to the loads. If the grid is not available, battery will provide backup power to the loads.

Load Supply Source (PV is unavailable): Loads will be supplied in one of the following options:

1. 1st Grid then 2nd Battery (Default): Grid will provide power to the loads first, if grid is not available battery will supply power to loads as back-up.
2. 1st Battery then 2nd Grid: Battery will provide power to the loads first. If battery voltage is low, the grid will power the loads.

NOTE: This option becomes ineffective during AC charging time, and the priority will default to Grid 1st and Battery 2nd order. Overriding this setting will cause the damage to the batteries and will Violate the terms of the Warranty.

Option 4: Grid-Tie with Backup (IV): Time of Use

Users are only allowed to set up the peak time and off-peak times for electricity demand, time-of-use (TOU) settings.

Working Logic Under Peak Time

PV Energy Supply Priority Setting: PV will supply energy in the following order:

1. Battery
2. Loads
3. Grid

PV will charge the battery first, if there is excess PV it will provide power to the loads. If there is remaining PV generation, it will feed-in to the grid. *Feed-in to the grid is disabled by default.*

Charging Source: PV Only

Only after PV power fully supports the loads is remaining PV power allowed to charge the battery during peak times.

Load Supply Source: Loads will be supported in the following order:

1. PV
2. Battery
3. Grid

PV will provide power to the loads first. If PV is not sufficient to support the loads the batteries will support the loads. If the battery reaches LBCO or cannot support the loads, the grid will provide power to the loads. When PV power is unavailable (nighttime), battery will supply the loads first. If the battery reached LBCO, the grid will back-up the loads.

Working Logic Under Off-Peak Time:

PV Energy Supply Priority Setting: PV will supply energy in the following order:

1. Battery
2. Load
3. Grid

PV will charge the battery first, if there is excess PV generation, it will provide power to the loads. If there is remaining PV generation, it will feed-in to the grid.

NOTE: The Max Feed-In Grid Power Setting is available in parameter settings within the software and should be set based on your utility interconnection agreement.

Charging Source: PV and Grid Charge Battery

PV generation will charge the battery first during off-peak times. If it is not sufficient, the grid will also charge the battery.

Load Supply Source: Loads will be supported in the following order:

1. PV
2. Battery
3. Grid

PV will provide power to the loads first. If PV is not sufficient to support the loads the batteries will support the loads. If PV power is not sufficient, the grid will provide power to the loads. If grid power is not available, battery power will provide power to the loads. If battery reaches LBCO System will shut down until grid or solar charging sources are re-established.

12.5 – Grid-Tie

Under this operational mode, PV power only feeds-in to the grid and batteries are not present in the system. A back-up generator can be wired into the system to provide load support during an outage. *There are no priority settings available for this selection*

12.6 – Off-Grid

Off-Grid settings should only be used if the utility is not present. There are three priority options for Off-Grid use. Off-grid systems require solar as a generation source and should incorporate a generator for times in which solar may not be present.

Option 1: Off-Grid (I): Default setting for off-grid mode

PV Energy Supply Priority Setting: PV will supply energy in the following order:

1. Load
2. Battery

PV power will provide power to the load first and then charge the battery. Feed-in to the grid is not available under this mode. At the same time, the AC input relay is connected in Inverter mode. That means the transfer time from inverter mode to battery mode will be less than 15ms. The inverter can power up to 12kW for 100ms to accommodate start up surges. This will avoid any overload fault because AC input can supply loads when connected loads is rated over the output capacity of the inverter for a short duration of time.

Charging Source: PV Only

1. PV or AC Input- Utilizes Generator or AC Coupled Solar for Charging Support
2. PV Only: Select this mode if off-grid with solar
3. None: Do not select this mode in Off-Grid setting as you will need some generation/charging source.

Load Supply Source: Loads will be supported in the following order:

1. PV
2. Battery
3. AC

PV will provide power to the loads first. If PV is not sufficient to support the loads the battery will support the load. If the battery reaches LBCO or cannot support the load, a generator can be utilized to provide additional power to support loads and charge battery. When PV power is unavailable (nighttime), battery will supply the load first. If the battery reached LBCO, the system will power down until an energy source returns and begins supplying the inverter.

Option 2: Off-Grid (II)

PV energy supply priority setting:

1. Battery
2. Load

PV will charge the battery first. After battery is fully charged, if there is remaining PV power left, it will provide power to the load. Feed-in to the grid is not available under this mode. At the same time, the Grid to Load relay is connected in Inverter mode. That means the transfer time from inverter mode to battery mode will be less than 15ms. This will avoid any overload fault because grid input can supply loads when the connected loads are rated over the output capacity of the inverter. (Bypass mode)

Battery charging source:

1. PV or AC Input- Utilizes Generator or AC Coupled Solar for Charging Support
2. PV Only
3. None: Do not select this mode in Off-Grid setting as the ESS will need some generation source.

NOTE: AC charging duration is allowed in set-up.

Load supply source:

1. PV
2. Battery
3. AC

PV will provide power to the loads first. If PV is not sufficient to support the loads the batteries will support the loads. If the battery reaches LBCO or cannot support the loads, a generator can be utilized to provide additional power to support loads and charge battery. When PV power is unavailable (nighttime), battery will supply the loads first. If the battery reached LBCO, the system will power down until an energy source returns and begins supplying the inverter.

Option 3: Off-Grid (III)

PV Energy Supply Priority Setting: PV will supply energy in the following order:

1. Loads
2. Battery

PV will provide power to the loads first and any extra generation will charge the battery. Feed-in to the grid is not available under this mode. At the same time, the grid relay is NOT connected in Inverter mode. That means the transfer time from inverter mode to battery mode will be less than 15ms. If connected loads are over the rating of the output capacity of the inverter and AC input is available, the inverter will allow AC to provide power to the loads and PV will only charge the battery. Otherwise, this inverter will activate a fault protection.

Battery charging source:

1. PV or AC Input- Utilizes Generator or AC Coupled Solar for Charging Support
2. PV Only
3. None: Do not select this mode in Off-Grid setting as the ESS will need some generation source.

NOTE: AC charging duration is allowed in set-up

Load supply source (PV is available): Load will be supported in the following order

1. PV
2. Battery
3. AC

PV will provide power to the loads first. If it's not sufficient, battery will provide back-up power to the loads. If the battery reached LBCO, AC input will provide power to the loads.

Load Supply Source (PV is unavailable): Loads will be supplied in one of the following options:

1. 1st AC then 2nd Battery (Default): AC will provide power to the loads first, if AC is not available battery will supply power to loads as back-up.
2. 1st Battery then 2nd AC: Battery will provide power to the loads first. If battery voltage is low, the AC will power the loads.

NOTE: This option becomes ineffective during AC charging time, and the priority will default to AC 1st and Battery 2nd order. Overriding this setting will cause damage to the batteries and will Violate the terms of the Warranty.



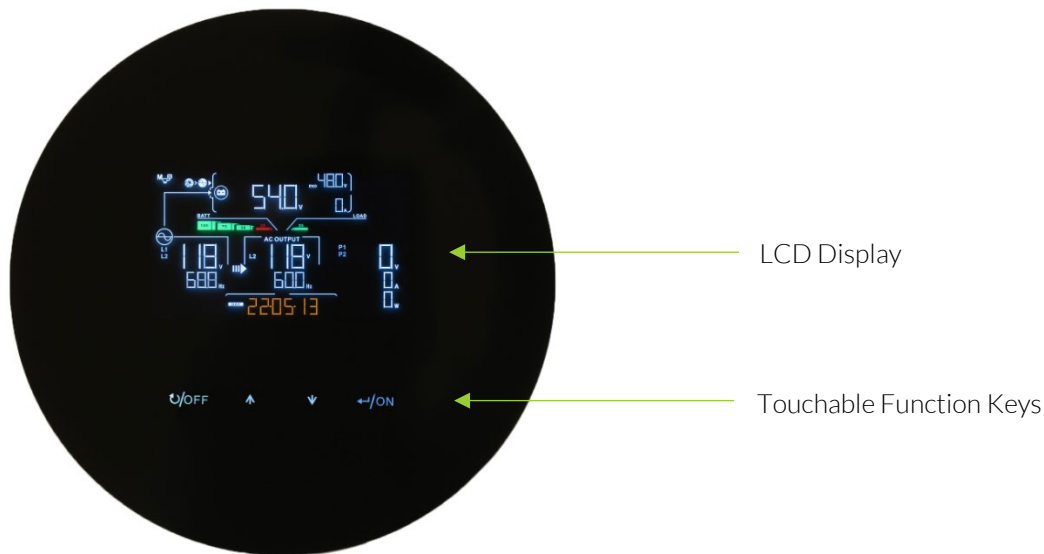



12.7- Interface

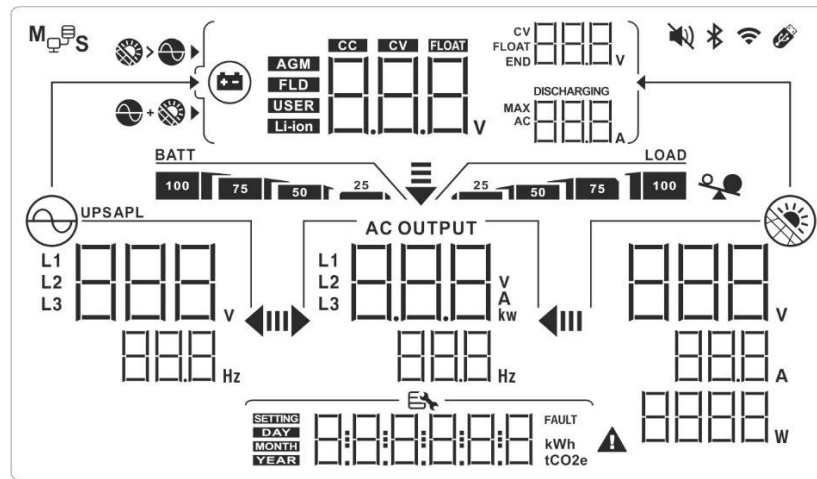

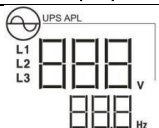
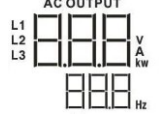
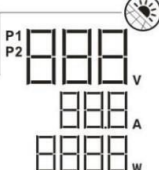

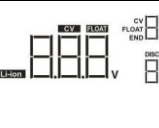

The operation LCD panel, shown in the chart below, includes four touchable function keys and an LCD display to indicate the operating status and input/output power information.

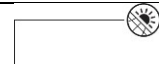

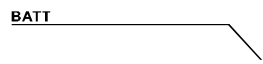
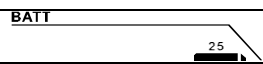
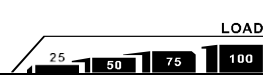
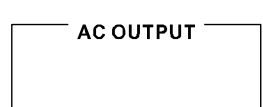

12.8- LCD Display Information



Display	Function
	<p>Indicates AC input voltage and frequency</p> <p>V: voltage, Hz: frequency, L1/L2: Line phase</p>
	<p>Indicates AC output power, voltage, frequency, or current.</p> <p>kw: active power, V: voltage, Hz: frequency, A: current L1/L2: AC output phase</p>
	<p>Indicates PV input voltage, power or current</p> <p>V: voltage, W: power, P1: PV input 1, P2: PV input 2A: current</p>
	<p>Icons illuminate when AC and PV charging is allowed</p>
	<p>Icon illuminates when only PV charging is allowed</p>
	<p>The following battery parameters are shown; voltage, battery current and charging status</p> <p>V: voltage, A: current, Li-ion: Lithium-ion battery</p>
	<p>Specifies battery level in battery mode</p>
	<p>Indicates the warning and fault codes</p>
	<p>Shows date and time or the date and time users set for querying energy generation</p>
	<p>Icon flashing alerts PV input voltage is out of range</p>

	Icon flashing alerts utility voltage or frequency is out of range
	Battery State of Charge indicator
	Icon flashing indicates battery is not allowed to discharge
	Warning! When flashing, the battery voltage is too low
	AC output for loads is permitted and inverter is providing power to the connected loads
	AC output for loads is allowed but there is no power provided from inverter. Only PV power is present but is not able to provide power to the connected loads
	Overload
	Parallel operation is working



12.9- Touchable Function Keys



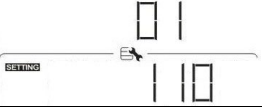
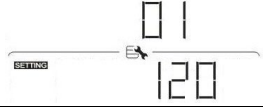

Function Key	Operation	Function
	Quick Touch	Enter query menu
	POWER ON: Touch and hold the button for approximately 1 second when the utility is detected or 3 seconds without the utility	If it's in query menu, touch this button to confirm selection or entry Turns on inverter to provide power to connected loads via AC output connector
	Quick Touch	Return to previous menu
	POWER OFF: Touch and hold the button until the buzzer continuously sounds	Turn off power to the loads
	Quick Touch	Select last selection or increase value
	Quick Touch	If in query menu, press this button to jump to next selection or decrease value
		Not in query mode, mutes alarm in standby mode or battery mode
	Touch and hold these two buttons for 2 seconds	Enter setting mode

NOTE: If backlight shuts off, you can activate by touching any button on the screen.

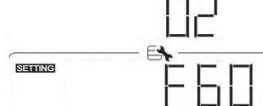
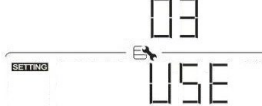
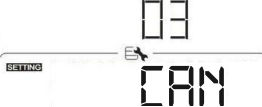
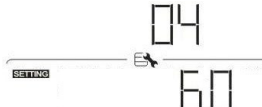
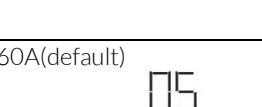
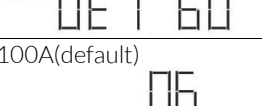
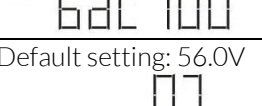



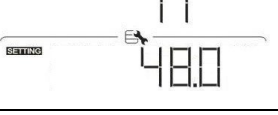
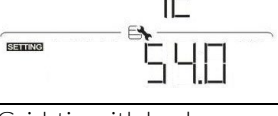
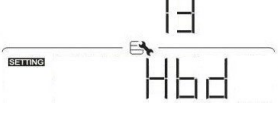
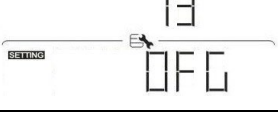
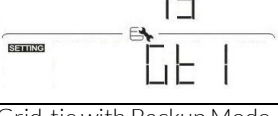

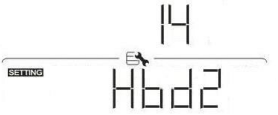

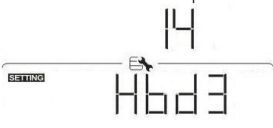
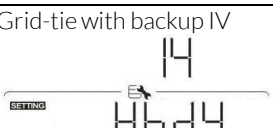
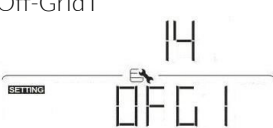
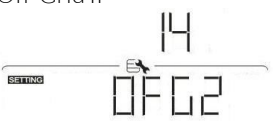
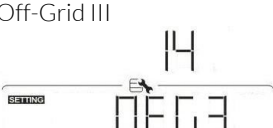
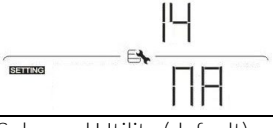
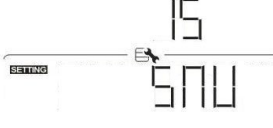
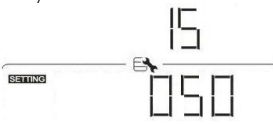
12.10- LCD Settings

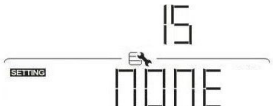

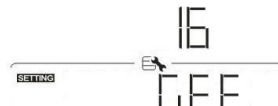

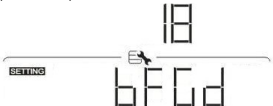

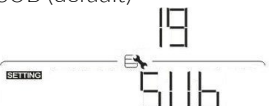
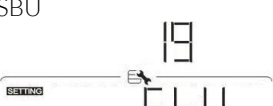
After touching and holding “UP” and “DOWN” button for **2 seconds**, the unit will enter setting mode. Press “UP” or “DOWN” button to select setting programs. And then, press “ENTER” button to confirm the selection or ESC button to exit.

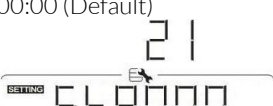

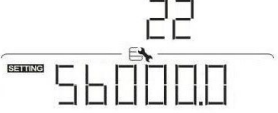



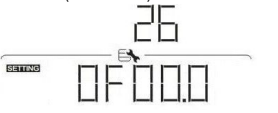
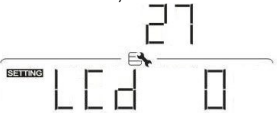
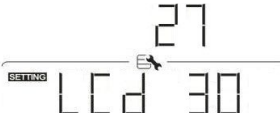
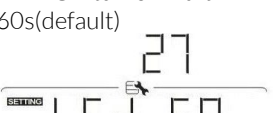



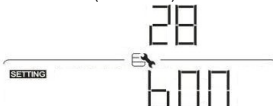
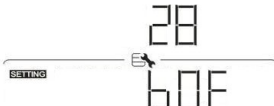

Program	Description	Selectable option	
00	Exit Setting Mode	Escape 	
01	Output Voltage	110Vac 	120Vac(default) 
02	Output Frequency	50Hz(default) 	60Hz 
03	Battery Type	User-Defined(default) 	When “User Defined” is selected as a battery type, battery charging voltage and low DC voltage cutoff can be set up in program 4, 7, 8 and 9 manually
		CAN 	When “CAN” is selected as a battery type, programs 4, 7, 8 and 9 will be automatically set up for SimpliPHI battery
04	Maximum Charging Current	60A(default) 	Setting range is 1A, then from 10A to 120A. Increment of each click is 10A To configure total charging current for solar and utility chargers. (Max. charging current = utility charging current + solar charging current)
05	Maximum Utility Charging Current	60A(default) 	Setting range is from 10A to 120A. Each click will increment by 10A
06	Maximum Discharging Current	100A(default) 	Setting range is from 10A to 150A. Each click will increment by 10A
07	Bulk Charging Voltage (C.V. Voltage)	Default setting: 56.0V 	Setting range is from 48.0V to 60.0V. Each click will increment by 0.1V

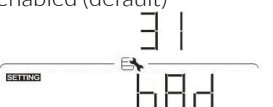

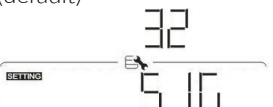

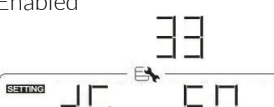
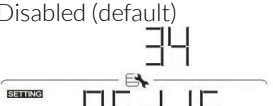

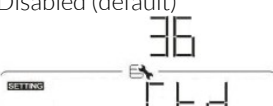
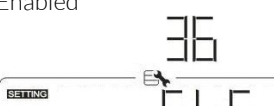
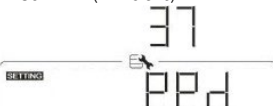
08	Floating Charging Voltage	Default setting: 54.0V 	Setting range is from 48.0V to 60.0V. Each click will increment by 0.1V
09	Low DC cut off battery voltage setting when grid is unavailable	Default setting: 42.0 	Setting range is from 40V to 60V. Each click will increment by 0.1V. This value will be dictated by the CAN connected battery voltage settings (Setting 3) within the BMS for LBCO.
10	Battery re-discharging voltage when grid is unavailable	Default setting: 48.0 	Setting range is form 40V to 60V. Each click will increment by 0.1V.
11	Low DC cut off battery voltage when grid is available	Default setting: 48.0 	Setting range is from 42V to 60V voltage. Each click will increment by 0.1V
12	Battery re-discharging voltage when grid is available	Default setting: 54.0 	Setting range is from 42V to 60V voltage. Each click will increment by 0.1V
13	Operation Mode	Grid-tie with backup 	PV power can feed-in back to the grid, provide power to the load and charge the battery
		Off-Grid 	It only provides PV power to the load and charges the battery. It is not able to feed back to the grid. Grid power is not available.
		Grid-Tie 	No batteries are present, PV power only powers loads and feeds back to the grid
		Grid-tie with Backup Mode	
		Grid-tie with backup I 	Battery-Load-Grid: PV will charge the battery first. Then it will provide power to the load. If there is any remaining power left, it will be fed into the grid.
		Grid-tie with backup II 	Load-Battery-Grid: PV will provide power to the load first. Then, it will charge the battery. If there is any remaining power left, it will be fed into the grid.

14	PV Supply Priority Setting	Grid-tie with backup III 	Load-Grid-Battery: PV will provide power to the load first. If there is more PV power available, it will be fed into the grid. If feed-in power reaches max.feed-in power setting, the remaining power will charge the battery.
		Grid-tie with backup IV 	TOU: If this mode is selected, it is only allowed to setup peak and off-peak times for electricity demand. Programs for 15, 17, 18, 19 and 20 can't be set and only programs for 21, 22, 23 and 24 can be set.
		Off-Grid Mode	
		Off-Grid I 	Load-Battery: PV power will provide power to the load first and then charge the battery. PV power cannot be fed back into the grid under this mode. Simultaneously, the grid relay is disconnected.
		Off-Grid II 	Battery-Load: PV will charge the battery first. After battery is fully charged, if there is remaining PV power left, it will provide power to the load. PV power cannot be fed back into the grid under this mode. Simultaneously, the grid relay is disconnected.
		Off-Grid III 	Load-Battery: PV will provide power to the loads first and any extra generation will charge the battery. PV power cannot be fed back into the grid under this mode. Simultaneously, the grid relay is disconnected.
		Grid-Tie Mode	
			The PV power only feeds into the grid. No priority setting is available. Batteries are not present in the system.
15	Charger source priority	Solar and Utility (default) 	PV will support loads first. If there is any remaining PV power after supporting the loads, it will charge the battery. If PV power is not available, grid will charge the battery.
		Only Solar 	PV is only available to charge the battery. Grid cannot charge the battery.

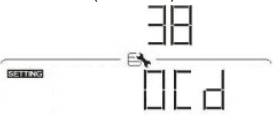
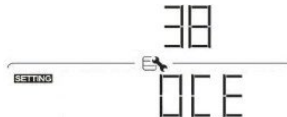
		None 	No charging is allowed via grid or PV power. This setting should not be used if batteries are in the system.
16	Feed to grid function	Feed to Grid Disabled (default) 	Feed to grid enabled 
17	Battery feed to grid function when PV is available	Battery feed to grid disabled (default) 	Battery feed to grid enabled 
18	Battery feed to grid function when PV energy is unavailable.	Battery feed to grid disabled (default) 	Feed to grid enabled 
19	Load supply source (PV is available)	SUB (default) 	Solar-Grid-Battery: PV will provide power to the load first. If it is not sufficient, grid will provide power to the load. If grid is not available, then the battery will provide power to the load.
		SBU 	Solar-Battery-Grid: PV will provide power to the load first. If it's not sufficient, the battery will provide power to the load. When battery is low or not available, the grid will back up the load.
20	Load supply source (PV is unavailable)	UB (default) 	Grid-Battery: Grid will provide power to the load first. If grid is not available, then the battery will provide power to the loads.
		BU 	Battery-Grid: Battery will provide power to the load first. If the battery is low or unavailable, grid will back up the load. This setting is ineffective during AC charging.
21	Start time system is allowed to charge from Grid or is connected to Grid	00:00 (Default) 	The time setting is from 00:00 to 23:00. Increment of each click is 1 hour. Suggested start time is 00:00 to begin the new day cycle at midnight.

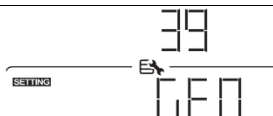
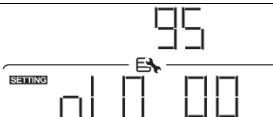
22	Start time system is to power loads from battery and not from Grid	00:00 (Default) 	The time setting range is from 00:00 to 23:00. Increment of each click is 1 hour. Recommend setting this at the beginning of the time you wish to go on battery during peak rate. Example: 16:00 (4PM) to leave grid support and power loads from battery.
23	Restart time system is allowed to charge from Grid or is connected to Grid	00:00 (Default) 	The time setting range is from 00:00 to 23:00. Increment of each click is 1 hour. Recommend setting this time when you wish to connect to the grid again. Typically, when peak rate charge ends. Example: 21:00 (9PM) to reconnect to grid and allow batteries to charge from grid.
24	Start time system is allowed to continue to be connected to grid to finish 24 hour cycle	00:00 (Default) 	The time setting range is from 00:00 to 23:00. Increment of each click is 1 hour. This should be the balance of time to complete a full 24 hours. Recommend this time to be set to 23:00 to end the days' time cycle. Time setting from Step 21 will begin after this step has completed in the cycle.
25	Scheduled time for AC output on	00:00 (Default) 	The time setting range is from 00:00 to 23:00. Increment of each click is 1 hour.
26	Scheduled time for AC output off	00:00 (Default) 	The time setting range is from 00:00 to 23:00. Increment of each click is 1 hour.
27	LCD off wait time	LCD is always on 	The LCD turns off after 30s 
		The LCD turns off after 60s(default) 	The LCD turns off after 300s. 
		The LCD turns off after 600s 	

28	Alarm control	Alarm on (default) 	Alarm off 
29	Alarm control at standby mode	Alarm "ON" in standby mode (default) 	Alarm "OFF" in standby mode 
30	Alarm control in battery mode	Alarm "ON" in battery mode (default) 	Alarm "OFF" in battery mode 
31	Activate lithium battery when the device is powered on	Lithium battery enabled (default) 	Lithium battery disabled 
32	AC Output Mode	Single: This inverter is used in single inverter application (default) 	Parallel: This inverter is operated in parallel system 
33	Generator as AC Source	Disabled (default) 	Enabled 
34	Wide AC Input Range	Disabled (default) 	Enabled 
36	External CT Function	Disabled (default) 	Enabled 
37	PV Parallel	Disabled (default) 	Enabled 

38	AC Coupling	Disabled (default) 	Enabled 
39	Generator Port		The port is deactivated, and cannot input or output
			The port is allowed as a generator input
95	Time Setting - Minute		For minute setting, the range is from 00 to 59
96	Time setting - Hour		the hour setting ranges from 00 to 23
97	Time setting - Day		The day setting range is from 00 to 31
98	Time setting - Month		The month setting range is from 01 to 12
99	Time setting - Year		The year setting range is from 17 to 99



13.0 – Wiring Diagrams

**SimpliPHI ESS Standard Wiring Diagram 120V/240V
with Generator**

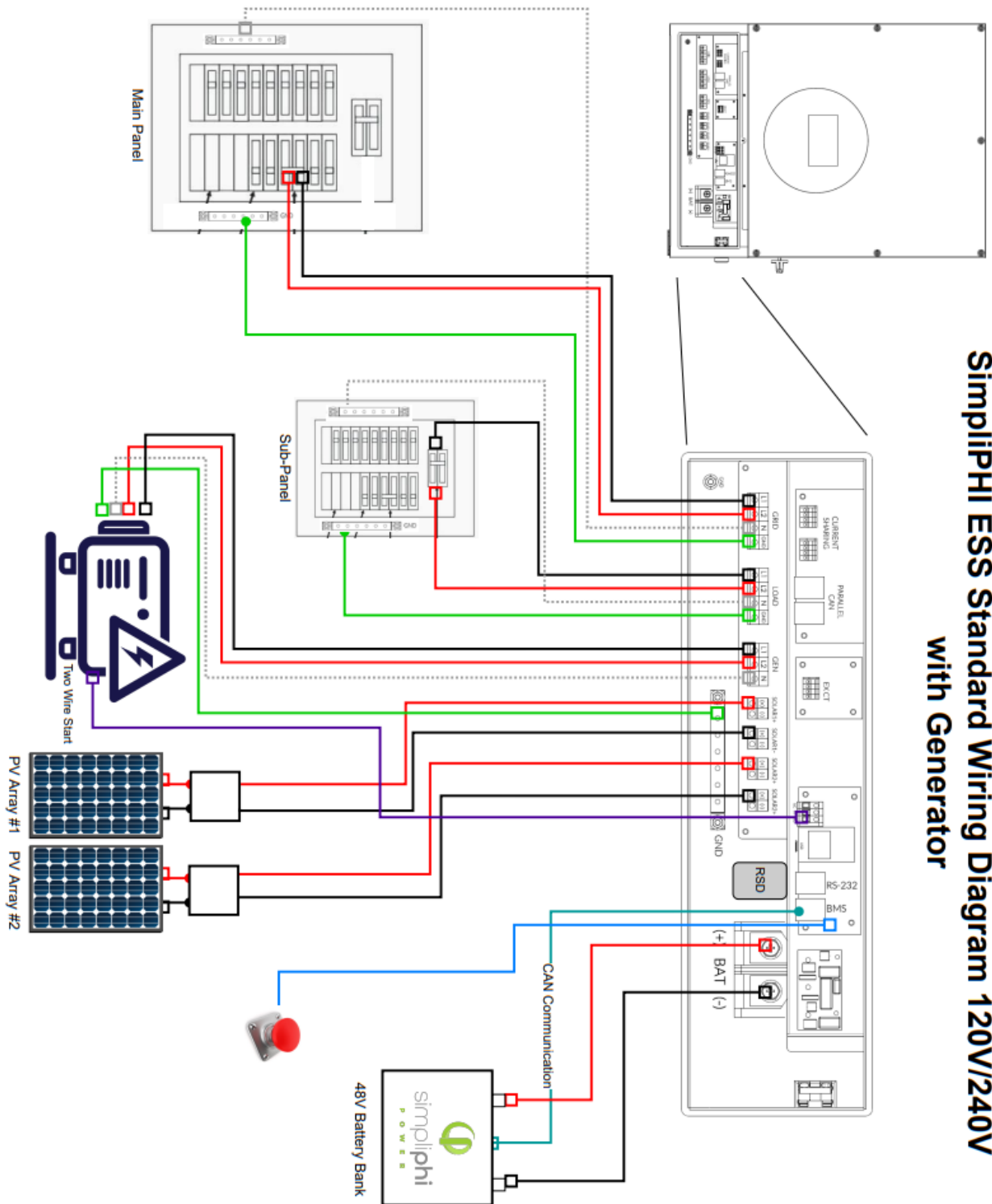

SimpliPHI ESS AC Coupling Wiring Diagram 120V/240V

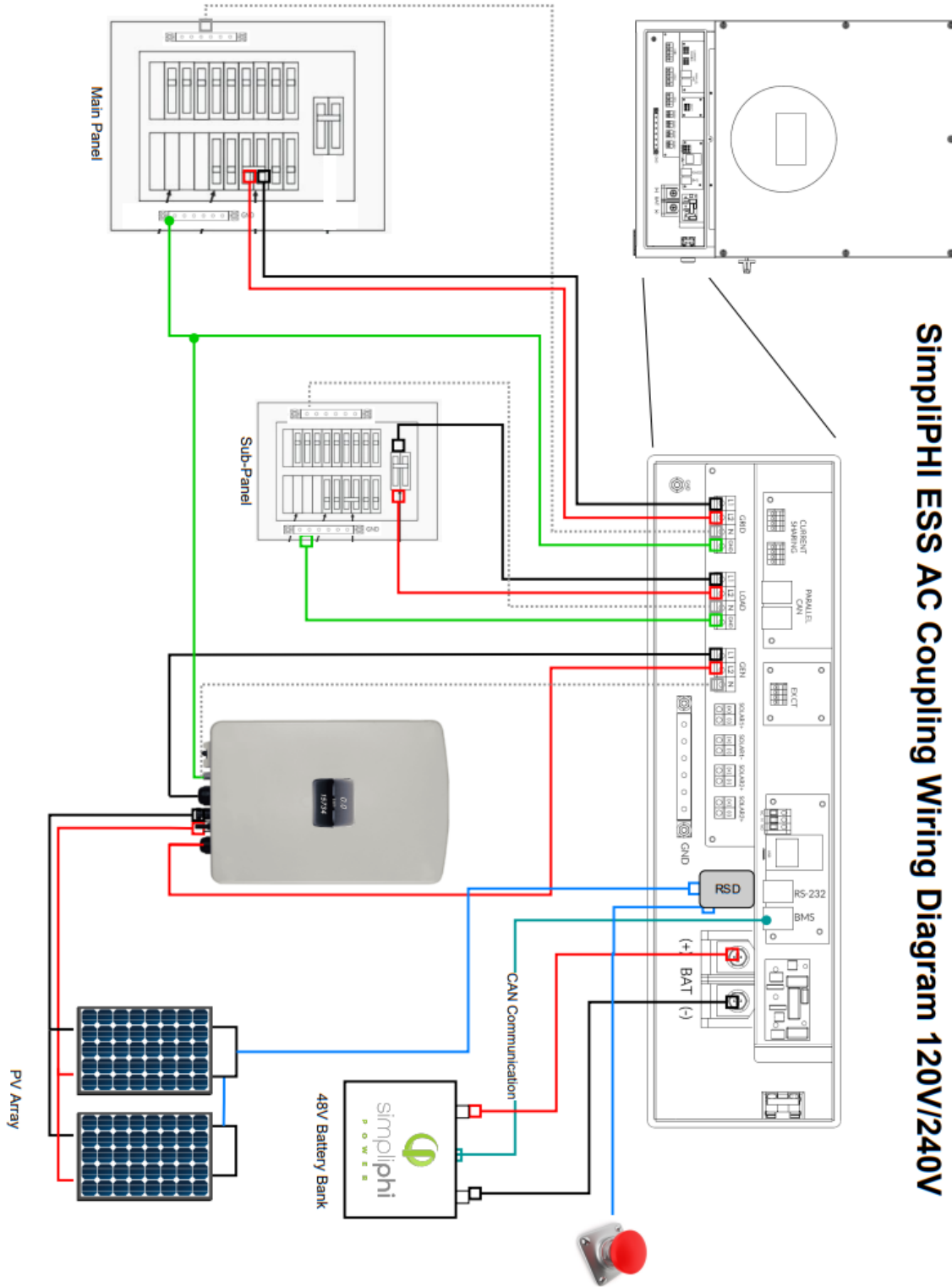

14.0 – Troubleshooting

If there is no information presented in the LCD display for a specific component, confirm that the PV modules, batteries and/or grid connection is correctly wired.

14.1 Warning List

There are 18 situations defined as warnings. When a warning situation occurs, the front panel display will show a flashing icon . Touch “up” or “down” to cycle through and select the displaying warning code. If there are several codes, it will display in sequence. Resolving the warning will remove the warning from the display on the inverter.

Code	Warning Event
01	Grid Voltage High (Out of Range)
02	Grid Voltage Low (Out of Range)
03	Grid Frequency High (Out of Range)
04	Grid Frequency Low (Out of Range)
05	Disconnected from Grid due to Continued High Voltage
06	Ground Not Detected
07	Island Operation Detected
08	Grid Waveform Not Acceptable
09	Grid Phase Lost or Reversed
11	Load Output Overload Detected
12	High Temperatures Detected
13	Battery Voltage Low
14	Battery Under Voltage
15	Battery Voltage Not Detected
16	Battery Voltage Low in Hybrid Mode
17	High Voltage Detected on PV Input
32	DSP and Comms Lost (Internal)

14.2 Fault Codes and Resolution

When a fault occurs, the **ERROR** icon will flash as a reminder. The below table shows the various faults and a resolution path.

Fault Code	Description	Possible Cause	Resolution
01	DC Bus Over Voltage	Surge	<ol style="list-style-type: none"> 1. Restart the inverter 2. If the error message remains, contact technical support
02	DC Bus Under Voltage	PV or battery disconnected suddenly	<ol style="list-style-type: none"> 1. Restart the inverter 2. If the error message remains, contact technical support
03	DC Bus Soft Start Time out	Internal component failure	Contact technical support
04	Inverter Soft Start Time Out	Internal component failure	Contact technical support
05	Inverter Max Current Exceeded	Surge	<ol style="list-style-type: none"> 1. Restart the inverter 2. If the error message remains, contact technical support
06	Inverter Max Internal Temp Exceeded	Internal temperature is too high	<ol style="list-style-type: none"> 1. Check the ambient temperature and fan operation 2. If the error message remains, contact technical support
07	Internal Relay Fault	Internal component failure	Contact technical support
08	CT Sensor Fault	Internal component failure	Contact technical support
09	PV Input Max Voltage Exceeded	Solar input power exceeds 600V	<ol style="list-style-type: none"> 1. Reduce solar input voltage to below 600V
11	PV Input Max Current Exceeded	Surge	<ol style="list-style-type: none"> 1. Restart the inverter 2. If the error message remains, contact technical support
12	PV Ground Fault Detected	Leakage current exceeds the limit	<ol style="list-style-type: none"> 1. Check wiring and solar modules which may contribute to leakage
13	PV ISO Fault Detected	Resistance between PV and ground is too low	<ol style="list-style-type: none"> 1. Check the wiring and solar modules which may cause issues
14	Inverter DC Max Current Detected	Utility Fluctuations	<ol style="list-style-type: none"> 1. Restart the inverter 2. If the error message remains, contact technical support
16	GFCI Sensor Fault (Internal)	GFCI sensor failure	Contact technical support
22	Battery Voltage Exceeded Limit	Battery voltage exceeds recommended limits	<ol style="list-style-type: none"> 1. Check the battery voltage and correct

23	Load Output Sustained @ 110% for Max Allowed Time	Inverter is loaded with more than 110% load for more than allowable time	Reduce the connected load to the inverter system, or by switching off loads
26	Load Out Short Circuit Detected	Output has short circuited	Check is wiring is connected correctly and remove any abnormal loads
27	Fan Fault Detected	Fan has failed	Contact technical support
32	DC Over Current Detected	Battery voltage is fluctuating	<ol style="list-style-type: none"> Restart the inverter If the error message remains, contact technical support
33	Load Output Voltage Low	Internal component failure	Contact technical support
34	Load Output Voltage Exceeded	Internal component failure	Contact technical support
35	Internal Wiring Fault	Internal wires are loose	Contact technical support
36	Output Terminal Voltage Fault (Input connected to Output)	Grid is connected to the output terminal	Rewire the inverter correctly following installation instructions
50	Incompatible Firmware Versions	Inverter hardware does not match firmware	Contact technical support to update firmware, or reload approved firmware version
60	Negative Power Detected	Possible AC Coupling not enabled and power feeding in. Parallel wiring may not be accurate	<ol style="list-style-type: none"> Check AC Coupling settings (if applicable) Check if L1/L2/N cables are not connected or in wrong sequence in inverters Make sure all sharing cables are connected in all inverters If error remains, contact tech support
71	Parallel Version is Incompatible	Firmware or operating profiles between two inverters are not the same	<ol style="list-style-type: none"> Check firmware version on both inverters and update if necessary Check operating profile of both inverters and update if necessary
72	Abnormal Output Current Detected	Output current of each inverter is different	<ol style="list-style-type: none"> Check that all current sharing cables are connected properly and restart the inverter. Check that load panel is balanced properly If error remains, contact tech support
80	CAN Comms Not Detected	Battery is not communicating with inverter	<ol style="list-style-type: none"> Check the communications cable connection to the inverter. Check the communications cable connection to the batteries

			3. Restart the inverter
81	Host Not Detected	Communications lost	Contact technical support
82	SYN Not Detected	Communications lost	Contact technical support
88	BUS Balance Over Current	Current on DC Bus is over recommended values	<ol style="list-style-type: none"> 1. Restart the inverter 2. If the error message remains, contact technical support