

REV	DESCRIPTION	APPROVAL	DATE

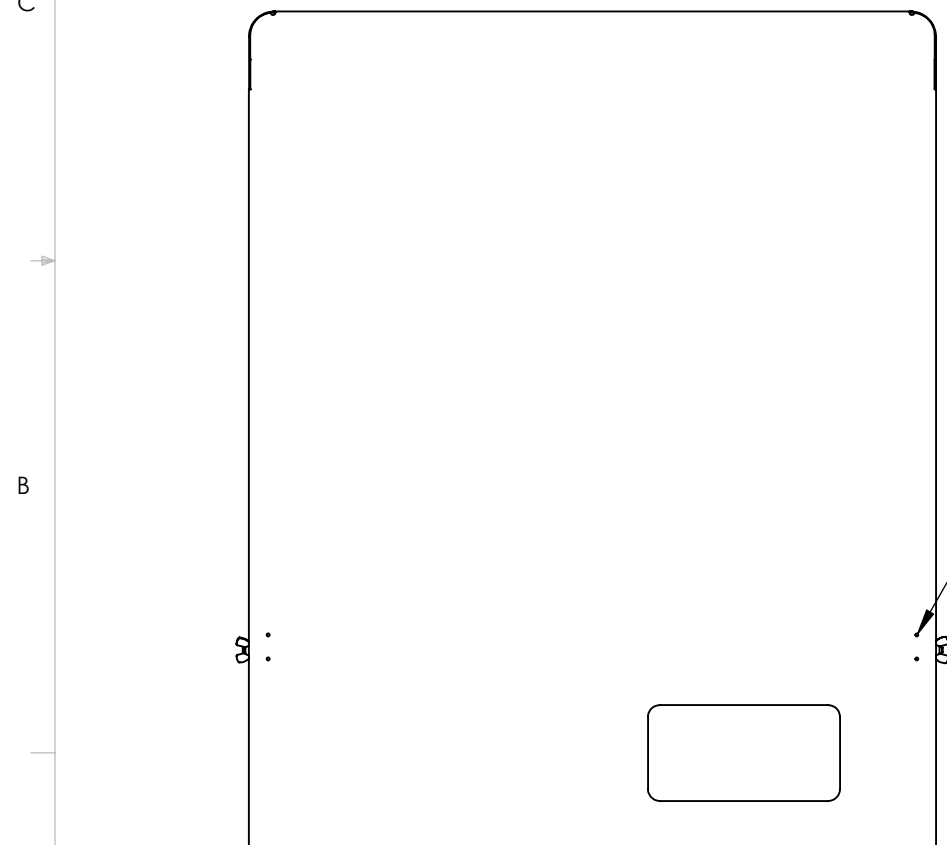

FILL ALL CLEKO HOLES  
GRIND SMOOTH

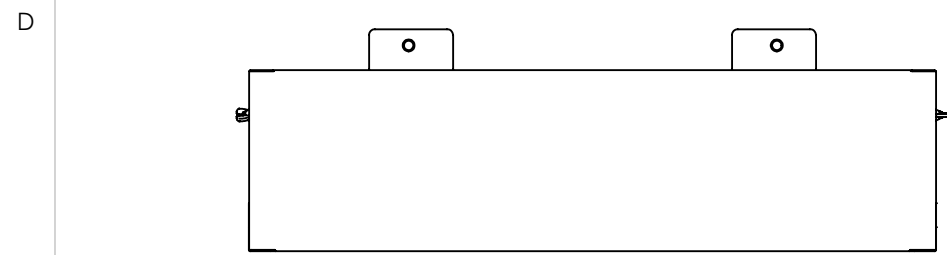
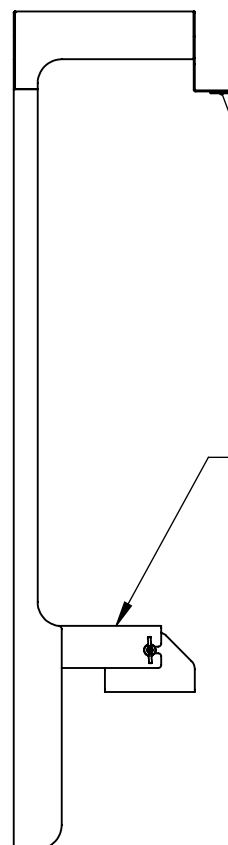

NYLON WASHERS  
(KIT FOR SHIPPING)

FILLET WELD BRACKETS  
ON INSIDE ONLY (2X)

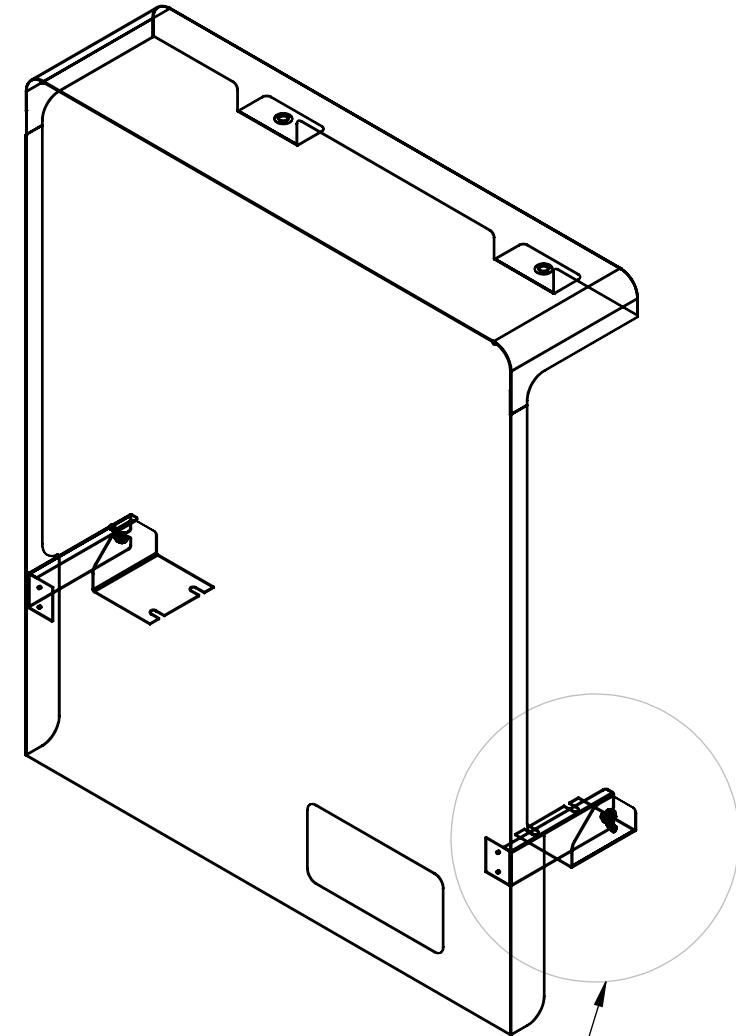

BOLT ON BRACKETS (2X)  
(KIT FOR SHIPPING WITH WING NUTS)



SPRAYLAT PEB-18994 ANODIZED ALUMINUM

UNLESS OTHERWISE SPECIFIED:	
DIMENSIONS ARE IN INCHES	
TOLERANCES:	
ANGLES: ± 1°	
DECIMALS: .XX ± .02	
.XXX ± .005	
INTERPRET GEOMETRIC TOLERANCING PER: ANSI STD Y14.5	
MATERIAL	VARIOUS
FINISH	POWDERCOAT
DO NOT SCALE DRAWING	

NAME	DATE
P. CULLEN	--/--
DRAWN	
CHECKED	
ENG APPR.	
MFG APPR.	
Q.A.	
COMMENTS:	

ADVANTAGE METAL PRODUCTS		
TITLE:		
SIZE	DWG. NO.	REV
B	SUNSHADE ASSEMBLY	3
SCALE: 1:8	WEIGHT:	SHEET 1 OF 1

NEXT ASSY	USED ON
APPLICATION	



REV	DESCRIPTION	APPROVAL	DATE

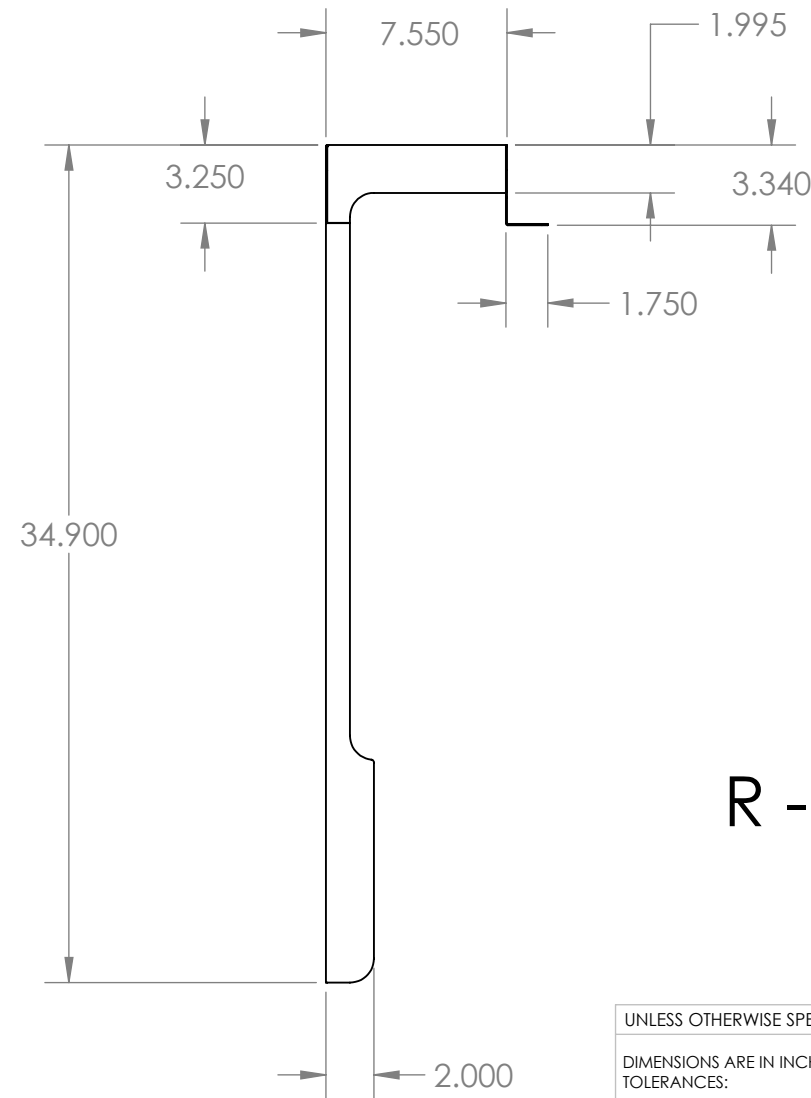
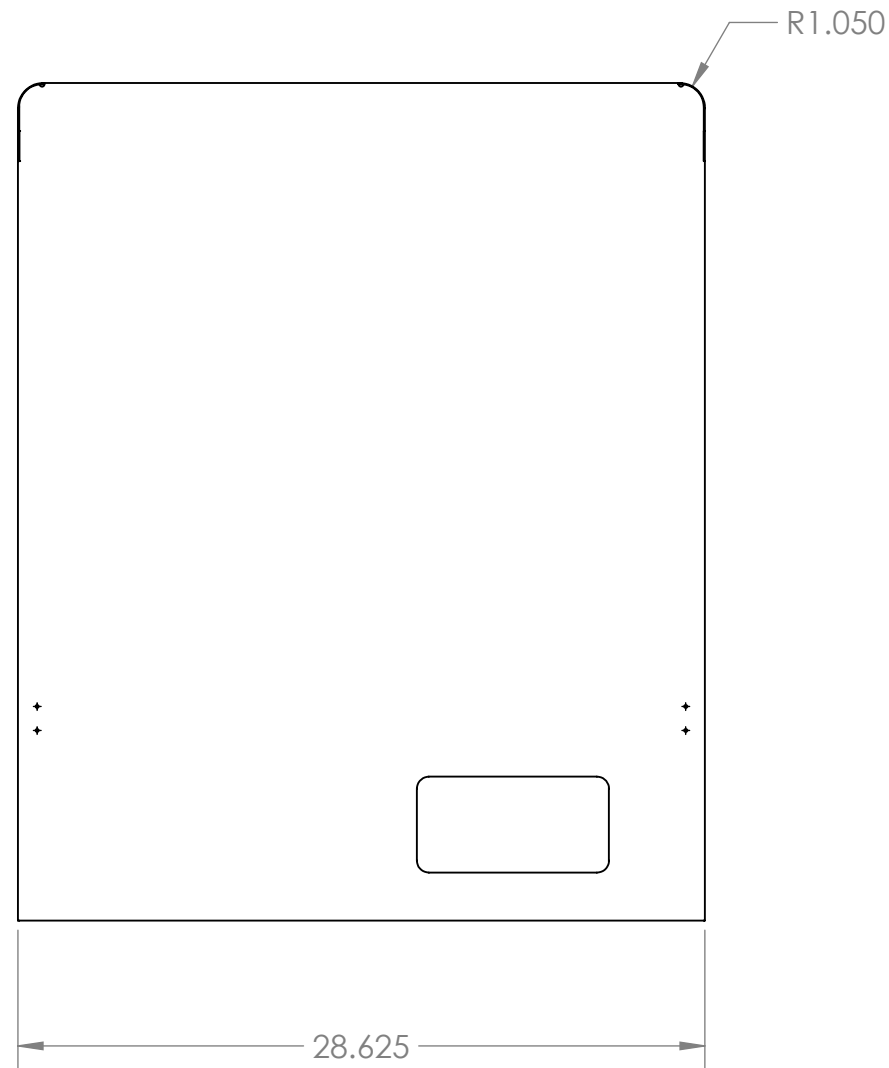
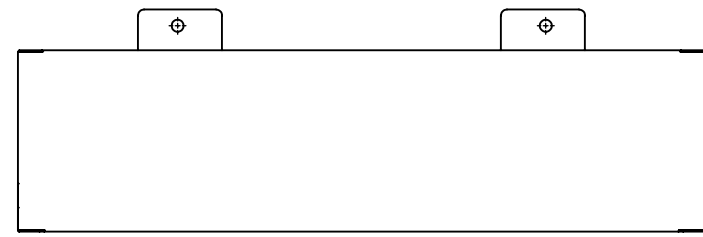

WELD ALL SEAMS SOLID AND BLEND CORNERS

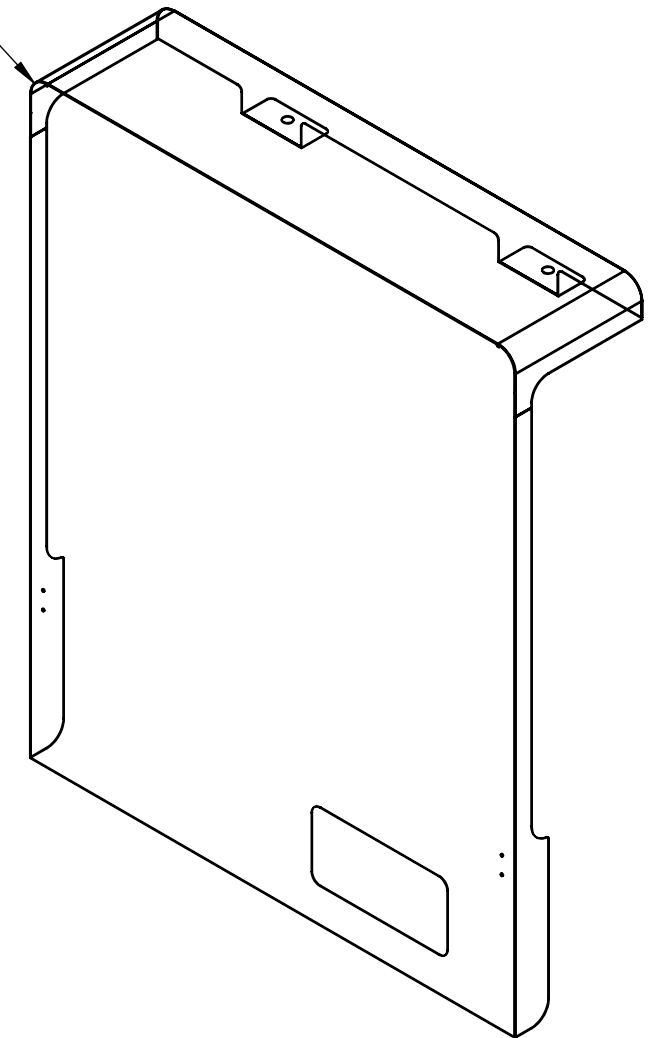

R - 1/32 K - .080



UNLESS OTHERWISE SPECIFIED:		NAME	DATE	 <b>ADVANTAGE METAL PRODUCTS</b>
DIMENSIONS ARE IN INCHES TOLERANCES:		DRAWN	P. CULLEN	
ANGLES: ± 1° DECIMALS: .XX ± .02 .XXX ± .005		CHECKED		TITLE:
INTERPRET GEOMETRIC TOLERANCING PER: ANSI STD Y14.5		ENG APPR.		
MATERIAL		MFG APPR.		
FINISH		Q.A.		
NEXT ASSY		COMMENTS:		
USED ON				SIZE <b>B</b>
APPLICATION				DWG. NO. COVER
DO NOT SCALE DRAWING				REV 3
THIRD ANGLE PROJECTION				SCALE: 1:8
				WEIGHT:
				SHEET 1 OF 1