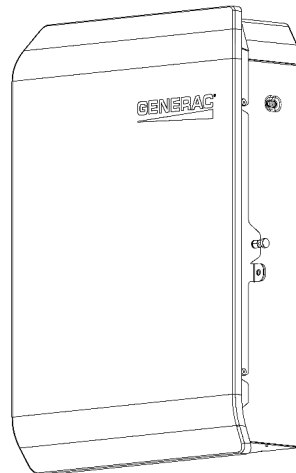
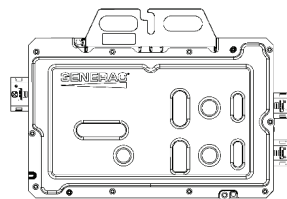

Installation Manual

PWRmicro and Smart Combiner

**⚠ WARNING**

Loss of life. This product is not intended to be used in a critical life support application. Failure to adhere to this warning could result in death or serious injury.

(W000209)

Register your Generac product at:
<https://pwrfleet.generac.com>
1-888-GENERAC
(888-436-3722)

SAVE THIS MANUAL FOR FUTURE REFERENCE

Use this page to record important information about this PWRmicro system.

Record the information on your data label on this page.

When contacting an Independent Authorized Service Dealer (IASD) or Generac Customer Service, always supply the complete model number and serial number of the unit.

Smart Combiner Serial Number	
Date Purchased	
Commissioning Date	
PV Array Size	
PV Module Model Number & Quantity	

 **CALIFORNIA WARNING**

This product can expose you to chemicals including benzene, a carcinogen and reproductive toxicant, which are known to the State of California to cause cancer and birth defects or other reproductive harm.

For more information, go to:
www.p65warnings.ca.gov

(P000808)

Table of Contents

Section 1: Safety Rules & General Information

Introduction.....	5
Read This Manual Thoroughly	5
Safety Rules	5
How to Obtain Service.....	5
General Rules	5
General Hazards	6
Electrical Hazards	6

Section 2: General Information

PWRmicro Specifications.....	9
Smart Combiner Specifications.....	10
Component Locations	11
Removing Front Cover and Dead Front.....	11
About PWRmicro and Smart Combiner	12

Section 3: Location Requirements and Dimensions

Location Requirements	13
Rapid Shutdown	13
Unit Dimensions	13
Minimum Clearances	14
Knockout Locations	15

Section 4: Installing PWRmicro

Installation Guidelines	17
Determining Configuration	17
Determining J-Box Location L/R	18
Positioning Micros on Racking System.....	18
Connecting AC Trunk Cables.....	18
Fastening Micros to Racking System.....	19
Connecting DC Cables.....	19
Installing AC and DC Connector Caps.....	20
Making Connections in J-Box.....	20
Creating the Array Map	20
Connecting PV Modules.....	21
Using PWRmicro Disconnect Tool	21
Observing PWRmicro Status LED	21

Section 5: Mounting Smart Combiner

Mounting Guidelines.....	23
Determining a Top Line	23
Fastening the Mounting Bracket	23
Punching Conduit Holes.....	24
Mounting and Fastening Smart Combiner	24

Section 6: Wiring Smart Combiner

Wiring Guidelines	25
Smart Combiner Wiring Compartment.....	25
Installing Circuit Breakers	26
Wiring PWRmicro Circuits.....	26
Interconnecting Smart Combiner	26
Tightening Connections.....	26
External CTs	27
Install External CTs	27
Control Wiring (if installing with PWRcell2).....	29

Section 7: Commissioning

Wiring Checks	31
Accessing the Installer App.....	31

Section 8: System Operation

General Information	33
Smart Combiner Status LED.....	33

Section 9: Maintenance

Service.....	35
--------------	----

Section 10: Array Map

Section 11: Measurement and Calculation Accuracy

Section 12: Voltage and Frequency Trip Thresholds

Voltage Trip	41
Frequency Trip	41

Section 13: Grid Support Functions

Grid Support Functions Parameter Values and Range of Adjustability	43
--	----

This page intentionally left blank.

Section 1: Safety Rules & General Information

Introduction

Thank you for purchasing a Generac PWRmicro system.

The information in this manual is accurate based on products produced at the time of publication. The manufacturer reserves the right to make technical updates, corrections, and product revisions at any time without notice.

NOTE: Wi-Fi® is a registered trademark of Wi-Fi Alliance®.

Read This Manual Thoroughly



WARNING

Consult Manual. Read and understand manual completely before using product. Failure to completely understand manual and product could result in death or serious injury. (W000100)

If any portion of this manual is not understood, contact the nearest Independent Authorized Service Dealer (IASD) for starting, operating, and servicing procedures. The owner is responsible for correct maintenance and safe use of the unit.

This manual must be used in conjunction with all other supporting product documentation supplied with the product.

IMPORTANT SAFETY INSTRUCTIONS. SAVE THESE INSTRUCTIONS for future reference. This manual contains important instructions which must be followed during placement, operation, and maintenance of the unit and its components. Always supply this manual to any individual who will use this unit, and instruct them on how to correctly start, operate, and stop the unit in case of emergency.

Safety Rules

The manufacturer cannot anticipate every possible circumstance that might involve a hazard. The alerts in this manual, and on tags and decals affixed to the unit, are not all inclusive. If using a procedure, work method, or operating technique that the manufacturer does not specifically recommend, verify that it is safe for others and does not render the equipment unsafe.

Throughout this publication, and on tags and decals affixed to the unit, DANGER, WARNING, CAUTION, and NOTE blocks are used to alert personnel to special instructions about a particular operation that may be hazardous if performed incorrectly or carelessly. Observe them carefully. Alert definitions are as follows:

DANGER

Indicates a hazardous situation which, if not avoided, will result in death or serious injury. (D000001)

WARNING

Indicates a hazardous situation which, if not avoided, could result in death or serious injury. (W000002)

CAUTION

Indicates a hazardous situation which, if not avoided, could result in minor or moderate injury. (C000003)

NOTE: Notes contain additional information important to a procedure and will be found within the regular text of this manual.

These safety alerts cannot eliminate the hazards that they indicate. Common sense and strict compliance with the special instructions while performing the action or service are essential to preventing accidents.

How to Obtain Service

When the unit requires servicing or repairs, contact Generac Customer Service at 1-888-GENERAC (1-888-436-3722) or visit www.generac.com for assistance.

When contacting Generac Customer Service about parts and service, always supply the complete model and serial number of the unit as given on its data decal located on the unit. Record the model and serial numbers in the spaces provided on the front cover of this manual.

General Rules

DANGER

Loss of life. Property damage. Installation must always comply with applicable codes, standards, laws and regulations. Failure to do so will result in death or serious injury. (D000190)

- Always consult local code for additional requirements for where unit is being installed.
- Incorrect installation can result in personal injury and damage to the unit. It may also result in the warranty being suspended or voided. All instructions listed below must be followed including location clearances and conduit sizes.

General Hazards



⚠ DANGER

Electrocution. Do not wear jewelry while working on this equipment. Doing so will result in death or serious injury.

(D000188)



⚠ WARNING

Electrocution. Potentially lethal voltages are generated by this equipment. Render the equipment safe before attempting repairs or maintenance. Failure to do so could result in death or serious injury.

(W000187)

⚠ WARNING

Risk of injury. Do not operate or service this machine if not fully alert. Fatigue can impair the ability to service this equipment and could result in death or serious injury.

(W000215)



⚠ WARNING

Loss of life. This product is not intended to be used in a critical life support application. Failure to adhere to this warning could result in death or serious injury.

(W000209)

⚠ WARNING

Equipment damage. Connecting inverter to electric utility grid must only be done after receiving prior approval from utility company. Failure to do so could result in equipment or property damage.

(W000640)

⚠ WARNING

Electric Shock. Only a trained and licensed electrician should perform wiring and connections to unit. Failure to follow proper installation requirements could result in death, serious injury, and equipment or property damage.

(W000155)

⚠ WARNING

Burns. Microinverter body is a heat sink and will be hot during and after operating. Shutdown microinverter and allow to cool before handling. Failure to do so could result in burns and serious injury.

(W000836)

⚠ CAUTION

Equipment Damage. Connect compatible equipment only. Connecting incompatible equipment could result in equipment and/or property damage.

(C000840)

- Connecting the PWRmicro system to the electric utility grid must only be done after receiving prior approval from the utility company.
- Only competent, qualified personnel should install, operate, and service this equipment. Strictly comply to local, state, and national electrical and building codes. When using this equipment, comply with regulations established by the National Electrical Code (NEC), and the Occupational Safety and Health Administration (OSHA), or the local agency for workplace health and safety.
- Protection against lightning surges in accordance with local electric codes is the responsibility of the installer.

NOTE: Lightning damage is not covered by warranty.

- Never work on this equipment while physically or mentally fatigued.
- Any voltage measurements should be performed with a meter that meets UL3111 safety standards and meets or exceeds overvoltage class CAT III.
- This equipment must be installed according to the manufacturer's installation instructions. Follow all instructions included in this manual and use appropriate practices for all product wiring and installation.

Electrical Hazards



⚠ DANGER

Electrocution. Water contact with a power source, if not avoided, will result in death or serious injury.

(D000104)



⚠ DANGER

Electrocution. Smart Combiner dead front cover should be removed by a qualified technician only. Improper removal of dead front cover will result in death, property damage, or serious injury.

(D000835)

⚠ DANGER

Arc Flash and Electric Shock. Do not attempt to unplug AC or DC connectors under load. Open PV breakers and render equipment inoperable before servicing. Failure to do so will result in death or serious injury.

(D000830)

**⚠ DANGER**

Electrocution. Verify electrical system is properly grounded before applying power. Failure to do so will result in death or serious injury.

(D000152)

**⚠ DANGER**

Electrocution. Turn off all parallel power sources, including feed from utility, before touching terminals. Failure to do so will result in death, serious injury, equipment, and property damage.

(D000837)

**⚠ DANGER**

Electrocution. In the event of electrical accident, immediately shut power OFF. Use non-conductive implements to free victim from live conductor. Apply first aid and get medical help. Failure to do so will result in death or serious injury.

(D000145)

This page intentionally left blank.

Section 2: General Information

PWRmicro Specifications

Description	Units	Value	
		Single Phase 240 V	Single Phase 208 V
Recommended Input Power	W	(300–500) x2	
Max. DC Input Voltage	V _{DC}	70	
Min – Max. Startup Voltage (Open Circuit)	V _{DC}	22.5 – 51	
MPPT Voltage Range	V _{DC}	31 – 42.5	
Max. Module I _{sc}	A	18	
DC Short Circuit Current Rating	A	21	
Ground Fault Protection	V _{rms}	2,000 ¹	
Max. Continuous Output Power	VA	820	
Max. Continuous Output Current	A	3.42	3.94
Nominal Output Voltage / Range	V _{AC}	240 / 211 – 264	208 / 183 – 229
Nominal Frequency	Hz	60	
Power Factor	—	-0.9 to 0.9	
Max. Overcurrent Protection Per Circuit	A	30	
Max. Number of PWRmicros Per 30 A Circuit	—	7	6
CEC Weighted Efficiency	%	97	
Peak Inverter Efficiency	%	97.3	97.1
Nighttime Power Consumption	mW	400	
Ambient Temperature Rating	°F (°C)	-40 (-40) to 149 (65)	
Enclosure Rating	—	Type 6	
Weight	lb (kg)	8 (3.63)	
Communication	—	Mesh Networked Power Line (Spread Spectrum Carrier)	
Monitoring	—	Smart Combiner	
Warranty	Years	25	
Certifications	UL 1741, UL 1741-SA, UL 1741-SB, IEEE 1547:2018/1:2020, IEEE 2030.5 CSIP, CA Rule 21, Rule 14H (HECO SRD V2.0), ISO-NE, PRC-024, Regulation No. 8915, FCC Part 15 Class B		

¹ Transformer isolated 2000 Vrms input/output/chassis

Smart Combiner Specifications

Description	Units	Value
Nominal Voltage Rating	VAC	120/240 single phase or 120/208 single phase
Busbar Rating	A	125
Max PV Output Current	A	100
Number of AC PV Circuits	2-Pole	5
Max. Number of PWRmicros	—	28 at 240 VAC (24 at 208 VAC)
Circuit Breaker Compatibility	—	Eaton 2-Pole Type BR
Production CT	A	200 ¹
Production CT Accuracy	%	Revenue Grade +/- 0.5
Consumption CT	A	200 ²
Compatibility	—	PWRmicro
Internet Connection	—	Wi-Fi® or Ethernet
Cellular Support ³	—	LTE
Ambient Temperature Range	°F (°C)	-40 (-40) to 131 (55)
Enclosure Rating	—	Type 3R
Weight	lb (kg)	29 (13.15)
Warranty	Years	10
Certifications	UL 1741, IEEE 1547-2018, IEEE 2030.5, ANSI C12.1:2024, FCC Part 15, Class B	

¹ 200 A solid core pre-installed and wired.

² Supports up to two pairs of consumption, net, and external production CTs.

³ Cellular built-in for remote support and firmware updates only.

Component Locations

See [Figure 2-1](#) for PWRmicro component locations. See [Figure 2-2](#) for Smart Combiner component locations.

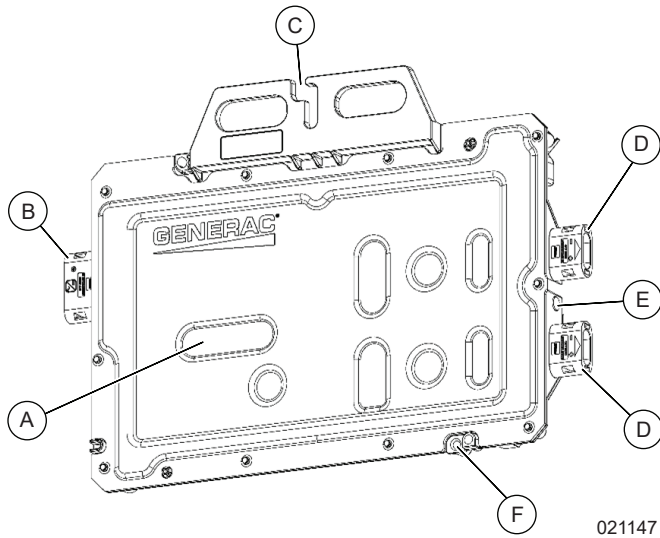

Figure 2-1. PWRmicro Component Locations

A	QR Code for Device ID
B	AC Output
C	Key Slot for Mounting
D	DC Inputs
E	Status LED
F	Hole for Cable Management

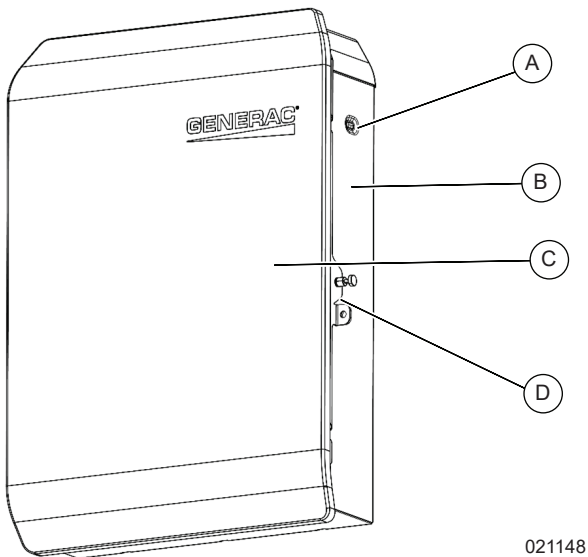

Figure 2-2. Smart Combiner Component Locations

A	Status LED
B	Nameplate
C	Front Cover
D	Fastener w/Locking Clasp

Removing Front Cover and Dead Front

See [Figure 2-3](#). Remove the front cover (A) on Smart Combiner by pulling captive fasteners (B) left and right. Remove the dead front (C) by loosening the fasteners (D) at the top and bottom.

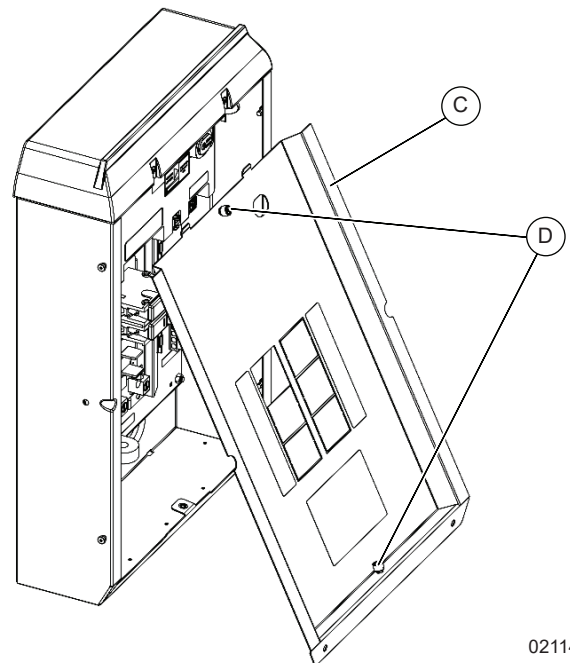
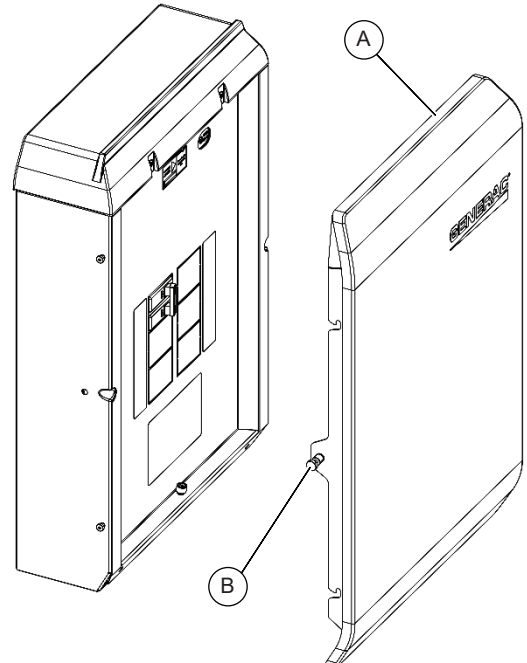

Figure 2-3. Removing Smart Combiner Front Cover and Dead Front

About PWRmicro and Smart Combiner

The PWRmicro 2:1 microinverter is a module-level inverter with two DC inputs compatible with most 60 cell and 72 cell PV modules. Up to seven PWRmicro inverters may be connected on one 240 VAC circuit terminated at the PWRmicro Smart Combiner. The PWRmicro Smart Combiner uses power line communications (PLC) to communicate with the PWRmicro inverters connected to its bus. Up to 28 PWRmicro inverters may be connected to one Smart Combiner.

See [Figure 2-4](#). The PWRmicro system connects PV modules (A) to PWRmicro inverters (B). PWRmicros connect to each other using modular trunk cables (C) before landing in junction box (D). From junction box (D), the AC PV circuit terminates at a 2-pole circuit breaker inside of the PWRmicro Smart Combiner (E). The Smart Combiner interconnects with a 2-pole breaker in the main panel (F) where PV power can distribute to home loads or export back to the utility through utility meter (G).

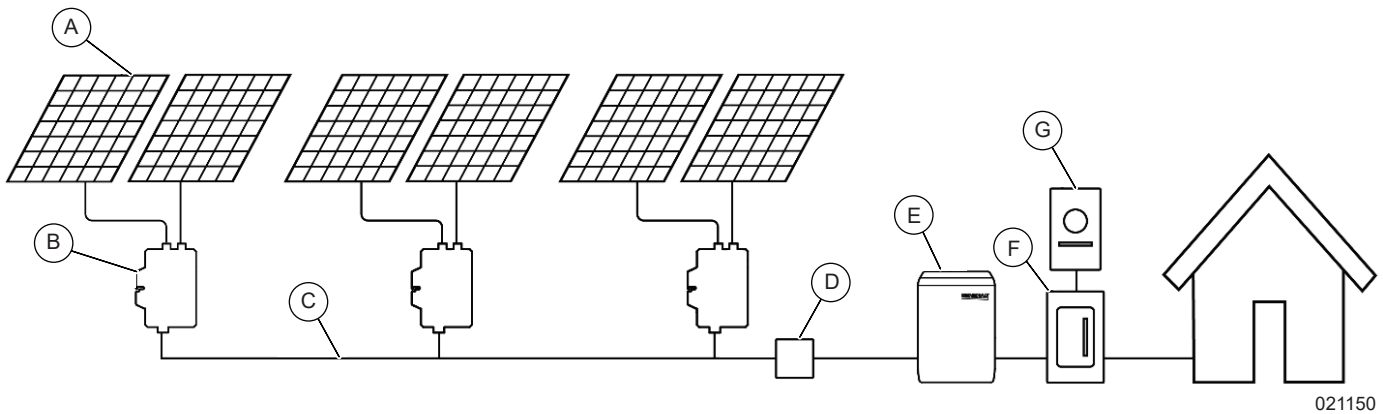

Figure 2-4. PWRmicro System Example

A	PV Modules	D	Junction Box	F	Main Panel
B	PWRmicro Inverters	E	Smart Combiner	G	Utility Meter
C	Modular Trunk Cables				

Section 3: Location Requirements and Dimensions

Location Requirements

Consider the following when installing PWRmicro and Smart Combiner:

- Verify ½ in (12.7 mm) of clearance on the top and bottom of each PWRmicro inverter.
- The Smart Combiner installation must meet the working space requirements in NEC Article 110.26.
- Install Smart Combiner at a minimum of 36 in (91.44 cm) from grade.
- Smart Combiner can be installed indoors or outdoors.
- Installation of the PWRmicro system must account for Rapid Shutdown per NEC 690.12.
- Do not mount Smart Combiner where liquids may be prone to drip or collect upon the equipment.

Rapid Shutdown

PWRmicro Inverters will cease operation immediately following disconnection from the utility grid, isolating PV modules to achieve module-level rapid shutdown.

If the 2-pole breaker in the main panel for the Smart Combiner will be outside near the utility meter and lockable in the OFF position, it may suffice as the rapid shutdown initiation device. Otherwise, install a disconnect or other compliant initiation device on the circuit for interconnection of the Smart Combiner per NEC 690.12.

NOTE: Installation must include labels identifying multiple sources of power on the equipment, and a placard indicating where to initiate rapid shutdown must be placed near the service entrance location.

Unit Dimensions

See [Figure 3-1](#) and [Figure 3-2](#) for dimensions of PWRmicro Inverter and Smart Combiner.

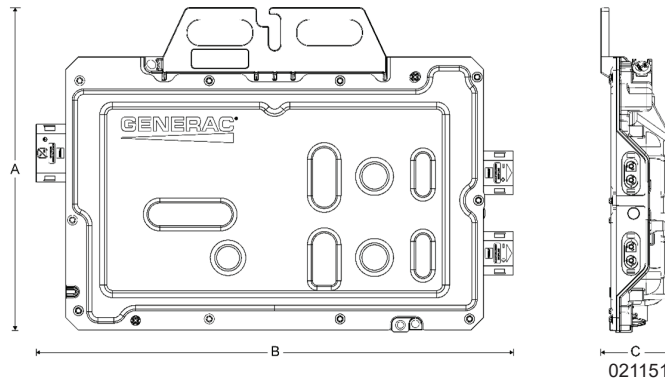

Figure 3-1. PWRmicro Dimensions

A	10–1/16 in (25.61 cm)
B	14–13/16 in (37.62 cm)
C	2–1/4 in (5.67 cm)

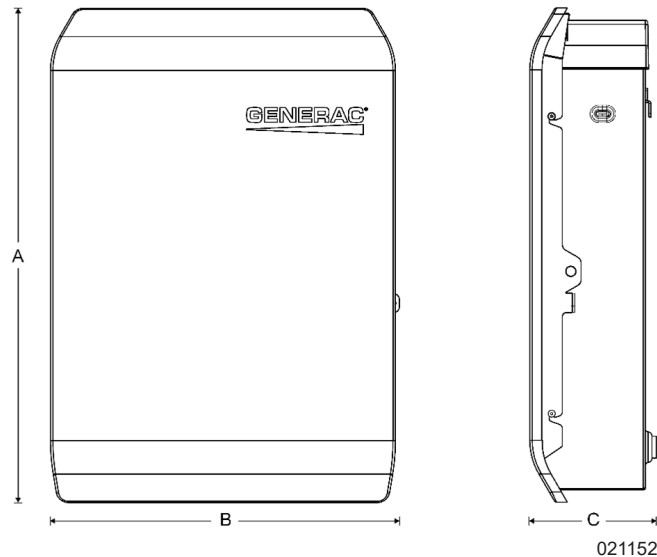
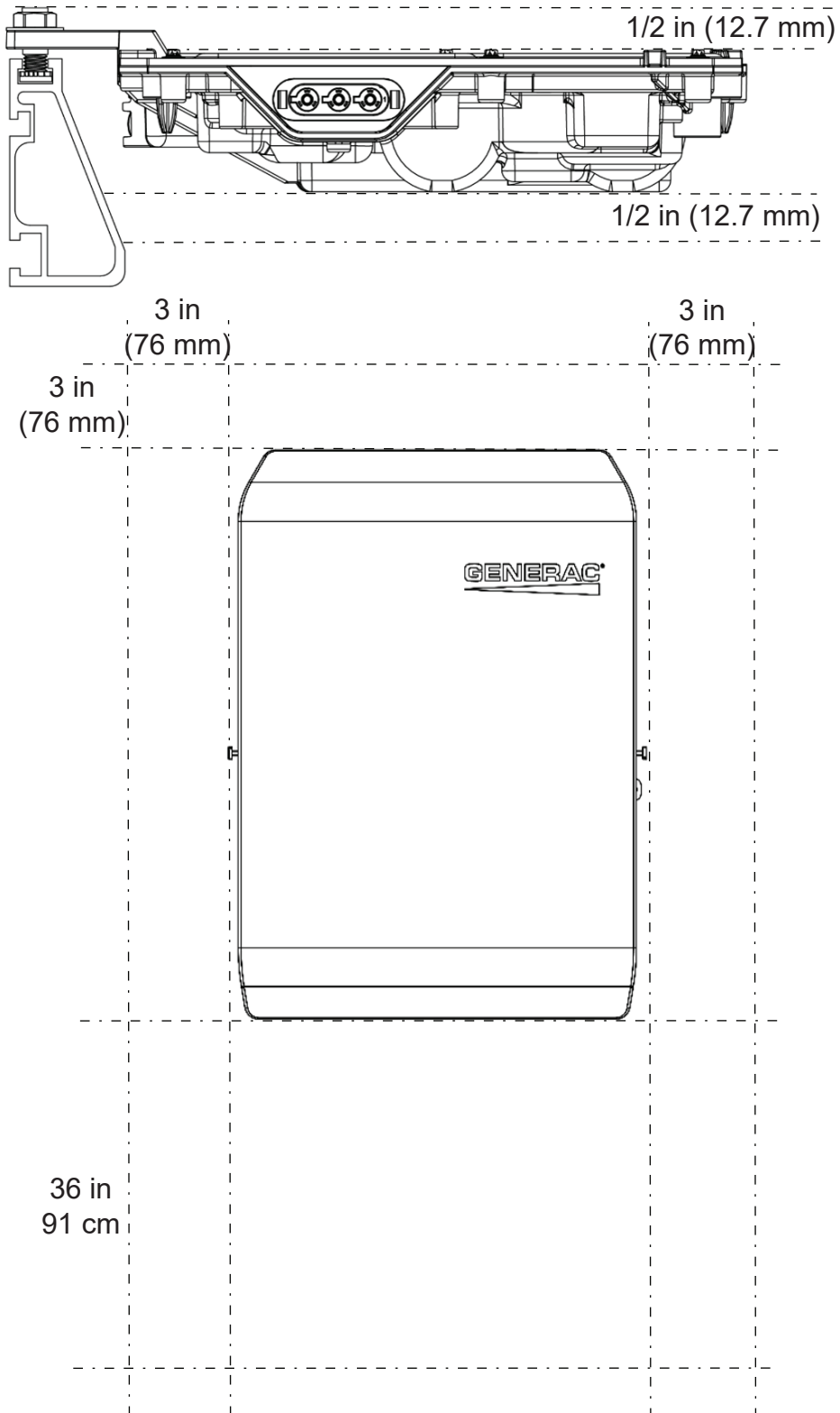

Figure 3-2. Smart Combiner Dimensions

A	23–7/8 in (60.67 cm)
B	16–11/16 in (42.39 cm)
C	6–1/8 in (15.55 cm)

Minimum Clearances



021153

Figure 3-3. Minimum Clearances

Knockout Locations

See [Figure 3-4](#). Knockouts may be punched in the shaded areas only.

NOTE: For wet locations: conduit, tubing, and cable fittings must be listed for raintight applications to comply with UL 514B. Also see 2023 NEC Article 314.15.

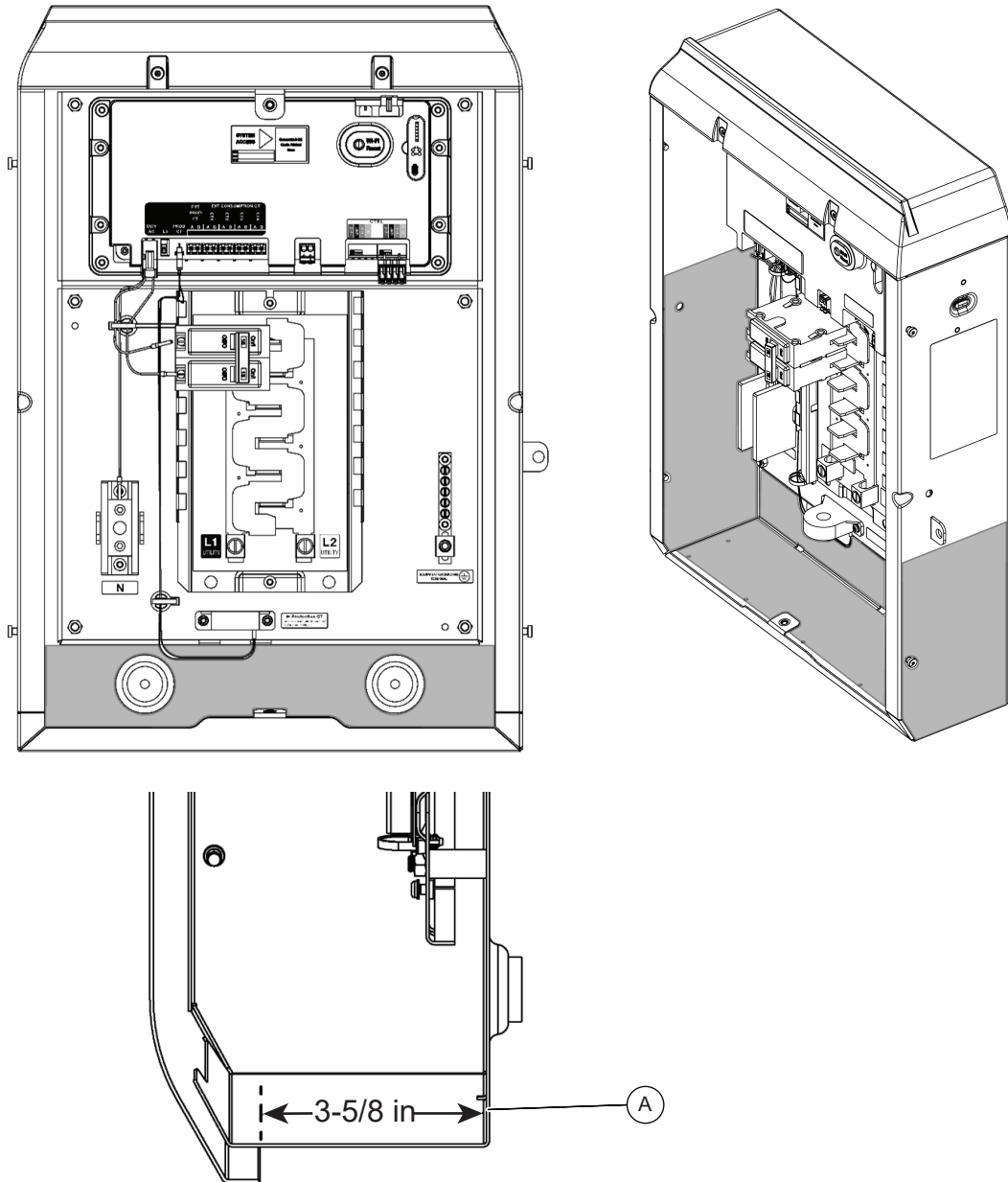

Figure 3-4. Knockout Locations

NOTE: To account for attaching the front cover, the bottom of the Smart Combiner enclosure allows 3–5/8 in (92.08 mm) of depth only for conduit entry or mounting devices such as a surge suppressor below the unit (A).

021162

This page intentionally left blank.

Section 4: Installing PWRmicro

Installation Guidelines



Equipment damage. Do not exceed maximum number of microinverters in an AC PV circuit (7 PWRmicros). Exceeding the maximum number of units may result in equipment damage.

(W000827)



Electric Shock. Only a trained and licensed electrician should perform wiring and connections to unit. Failure to follow proper installation requirements could result in death, serious injury, and equipment or property damage.

(W000155)



Equipment Damage. Connect compatible equipment only. Connecting incompatible equipment could result in equipment and/or property damage.

(C000840)

- Compare PV module specifications with PWRmicro specifications for compatibility.
- Use a digital multimeter (DMM) to measure AC voltage and frequency at the AC main panel prior to installation.
- Verify nominal voltage is single phase 120/240 VAC or single phase 120/208 VAC (from a Wye transformer only) before proceeding to install PWRmicro system.
- Verify nominal frequency is 60 Hz before proceeding to install PWRmicros.
- Verify minimum clearances of ½ in (12.7 mm) on top and bottom of PWRmicros.
- Always use wiring methods in accordance with National Electric Code (NFPA 70) or other applicable codes.
- Select appropriate OCPD for each AC PV circuit.
- Only install up to seven PWRmicro inverters per AC PV circuit.

Determining Configuration

See [Figure 4-1](#), [Figure 4-2](#), [Figure 4-3](#), and [Figure 4-4](#). The standard configurations below indicate how to pair PV modules with each PWRmicro Inverter depending on the number of rows portrait or landscape. Plan to mount PWRmicros on a single rail for AC PV circuits with up to two rows of PV modules.

NOTE: Standard configurations are provided as a starting point. Other configurations for complex roof layouts are acceptable.

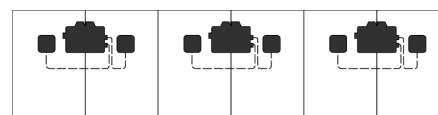

021163

Figure 4-1. Single Row Portrait



021165

Figure 4-2. Single Row Landscape

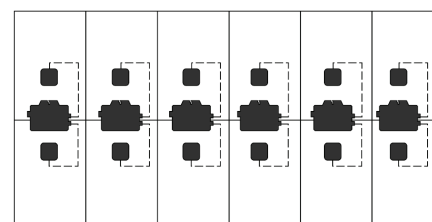

021166

Figure 4-3. Double Row Portrait

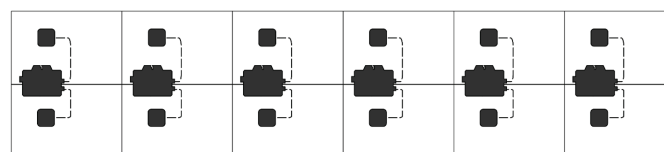

021167

Figure 4-4. Double Row Landscape

Determining J-Box Location L/R

Determine whether the AC PV junction boxes will be on the left or the right side of the array.

See [Figure 4-5](#). Use the j-box cable (L) if the junction box will be on the left side of the AC PV circuit.

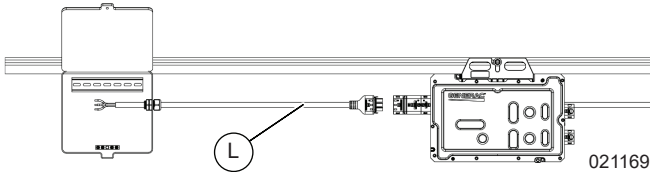

Figure 4-5. Lefthand Junction Box

See [Figure 4-6](#). Use the j-box cable (R) if the junction box will be on the right side of the AC PV circuit.

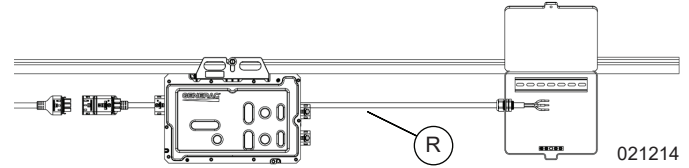
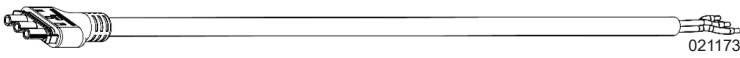



Figure 4-6. Righthand Junction Box

Table 4-1. Junction Box Cables

J-Box Cable	Length		Part Number
 021173	66.9 in (1.7 m)	L	APKE00090
 021174	66.9 in (1.7 m)	R	APKE00091

Positioning Micros on Racking System

Proceed as follows to position each microinverter.

1. See [Figure 4-7](#). Attach each microinverter (B) using the appropriate mounting hardware (A) for the racking system and secure loosely so the microinverter can slide along the rail.

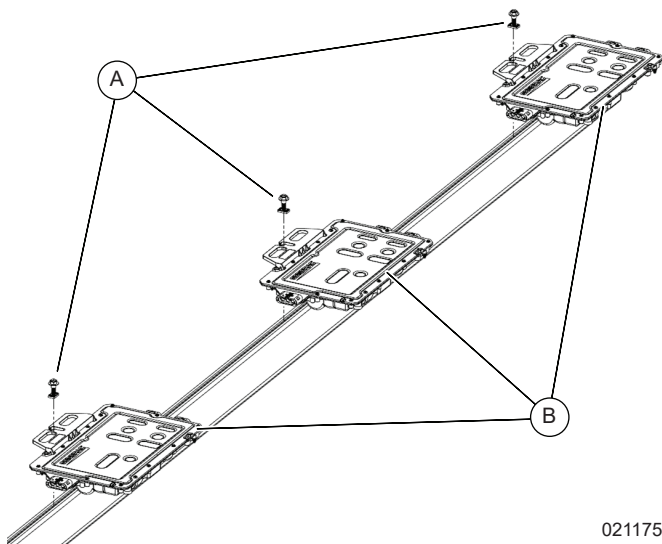

Figure 4-7. Positioning PWRmicros on Racking System

2. Position each microinverter so they will lie underneath the PV module with the chassis facing downward and the Generac logo facing up.

Connecting AC Trunk Cables

As installation may require different length trunk cables, it is important to lay out the cable sections to be sure sufficient materials are on hand for the desired layout.

1. Start with the j-box trunk cable as the first cable for each AC PV circuit and work towards the right or left accordingly.
2. See [Figure 4-8](#). The keyed male connector (A) of the first AC trunk cable will connect to the female connector (B) of the h-connector on the j-box trunk cable. Connectors should snap together easily. Verify each is securely fastened.

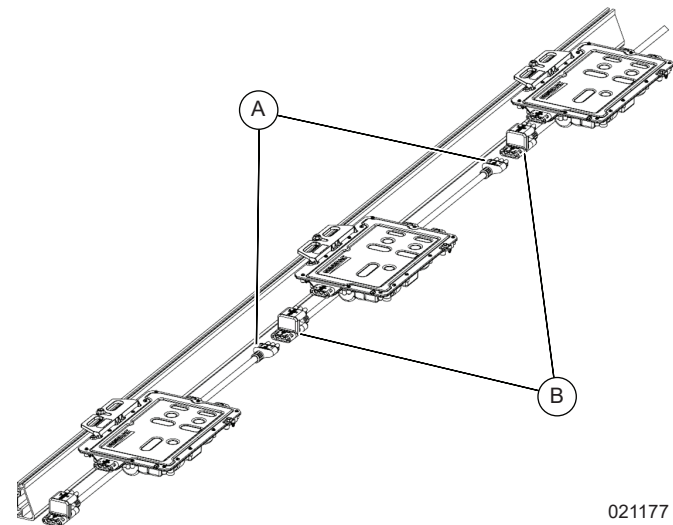

Figure 4-8. Connecting AC Trunk Cables

- Continue connecting the rest of the cables in this manner until the branch circuit is completed. Repeat this process for any additional AC PV circuits in the array.
- Use cable clips or wire ties to fix the cable to the racking, and use cable clamps included with

PWRmicros to fix the cable to the lower right corner of the micro as needed.

- Use waterproof cable caps to plug into any unused female ports on h-connectors. See [Table 4-4](#). See [Table 4-2](#). Order cables based on the lengths and part numbers provided.

Table 4-2. AC Trunk Cables

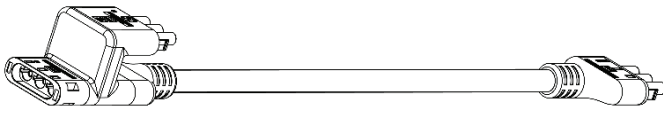
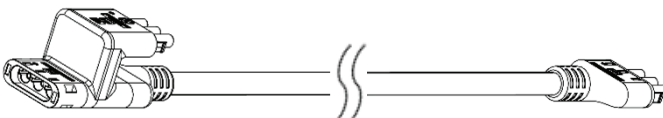
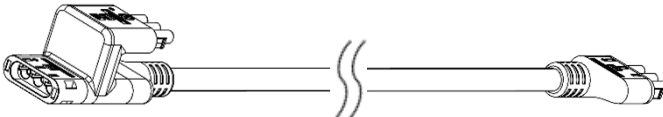
AC Trunk Cable	Length	Size	Part Number
	3 ft 11- $\frac{1}{4}$ in (1.2 m)	SM	APKE00084
	6 ft 6 in (2 m)	M	APKE00086
	7 ft 8- $\frac{1}{2}$ in (2.35 m)	L	APKE00088

Fastening Micros to Racking System

See [Figure 4-9](#). Once the microinverters have been positioned on the racking with the AC trunk cables

connected, fasten the micros to the rail using a torque wrench following the racking system torque specification for attaching module level power electronics (MLPE).

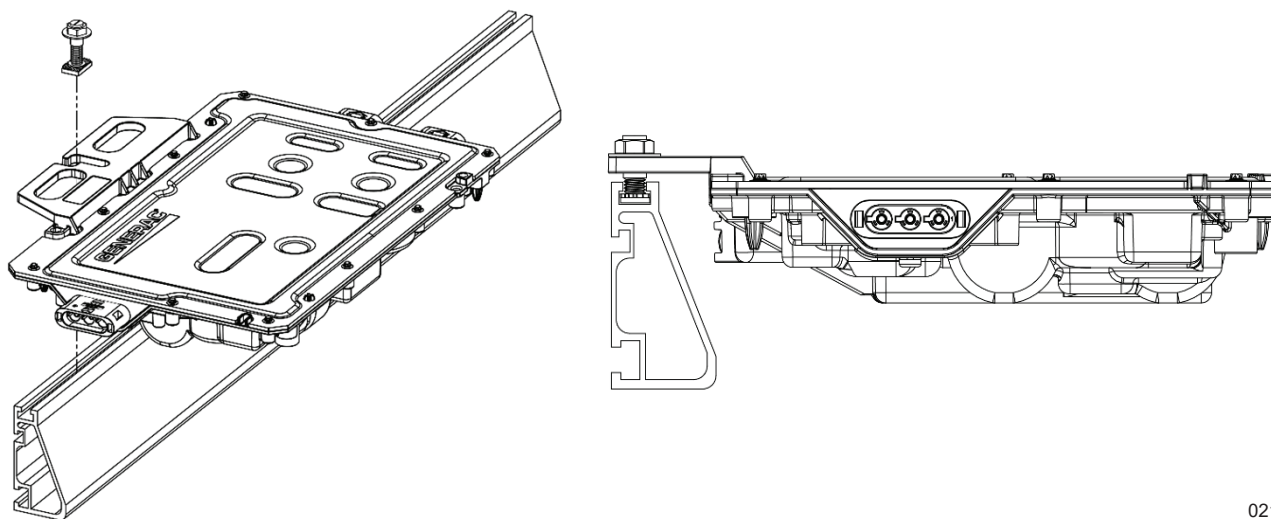

021180

Figure 4-9. Fastening PWRmicros

Connecting DC Cables

With the micros fastened and the AC trunk cables connected, connect the DC cables to the PWRmicro DC inputs.

See [Figure 4-10](#). Connect long DC cables (A) as needed for PV module connections which are further away from where the micros are mounted on the rail. Connect short DC cables (B) to PV modules which are closer to the micros.

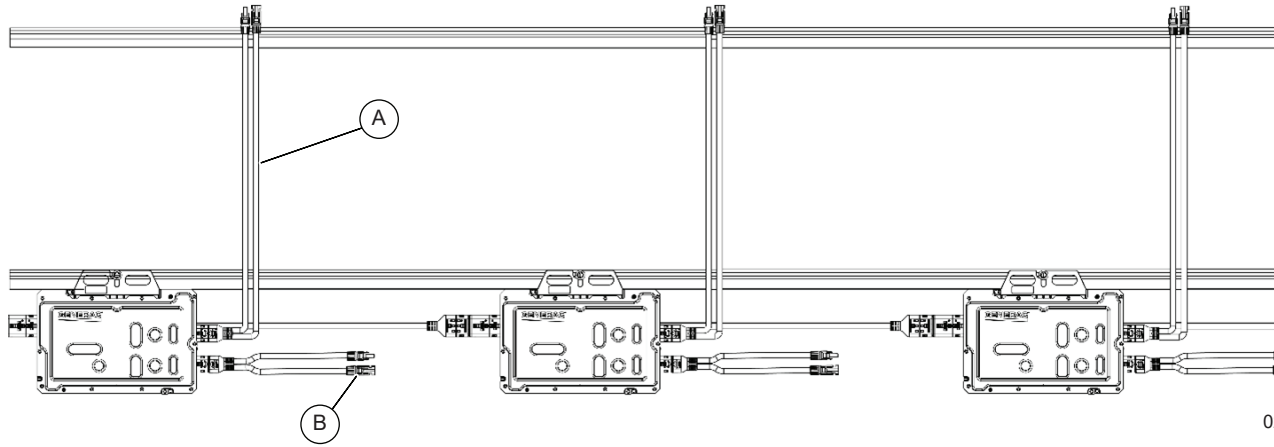

021183

Figure 4-10. Connecting DC Cables

See [Table 4-3](#). Source DC cables using the part numbers provided.

Table 4-3. DC Cables

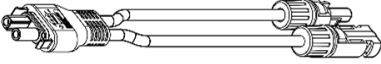
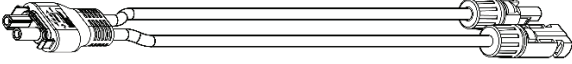

DC Cable	Length	Size	Part Number
	Short - 1 ft 2–3/4 in (38 cm)	Short	APKE00092
	Long - 3 ft 3–3/4 in (101 cm)	Long	APKE00094

Installing AC and DC Connector Caps

For all open ports on AC trunk cables and all open PWRmicro DC ports, verify connector caps have been installed.

See [Table 4-4](#) for description and part numbers.

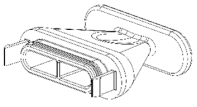
Table 4-4. AC and DC Connector Sealing Caps

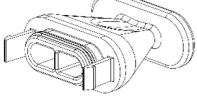
Cable cap	Description	Part Number
	AC Male Connector Sealing Cap	APKE00098
	AC Female Connector Sealing Cap	APKE00096
	DC Male Connector Sealing Cap	APKE00100

Making Connections in J-Box

Once the microinverters are fastened in place with AC trunk cables and DC cables connected, make connections for Line 1, Line 2, and Ground in junction boxes before connecting and laying PV modules.

NOTE: PV racking and PV modules must be grounded separately from PWRmicro System. See 3rd party manufacturer's instructions.

Creating the Array Map

After PWRmicros are installed and j-box connections are made, create an array map to indicate which microinverters are installed at each location within the array. Failure to do this will result in poor system monitoring and future service calls may require additional time, should the array need to be serviced later.

See [Array Map](#) for an array map template. Indicate PV module orientation as well as each PWRmicro inverter location with each unit's serial number.

Connecting PV Modules



⚠ WARNING

Equipment Damage. The maximum open circuit voltage of the PV module must not exceed the specified maximum voltage of the microinverter. Verify voltage and current specifications of PV module match the specifications of the microinverter. Connecting PV modules out of specification could result in equipment damage.

(W000829)

PWRmicro inverters are compatible with most 60-cell, 66-cell, and 72-cell PV modules, including variants with half-cut cells. See [Section 2: General Information](#) and review the [PWRmicro Specifications](#) table for more information.

After PWRmicros are installed and the array map is complete, connect up to two PV modules to each microinverter. For microinverters with only one PV module, cap the unused DC port.

Using PWRmicro Disconnect Tool

⚠ DANGER

Arc Flash and Electric Shock. Do not attempt to unplug AC or DC connectors under load. Open PV breakers and render equipment inoperable before servicing. Failure to do so will result in death or serious injury.

(D000830)

To disconnect any connections made using PWRmicro AC trunk cables or DC cables, use the PWRmicro Disconnect Tool.

See [Figure 4-11](#). Use AC end (A) to disconnect AC trunk cable connections. Use DC end (B) to disconnect DC connections at PWRmicro. Use side tool (C) to disconnect MC4 connections.

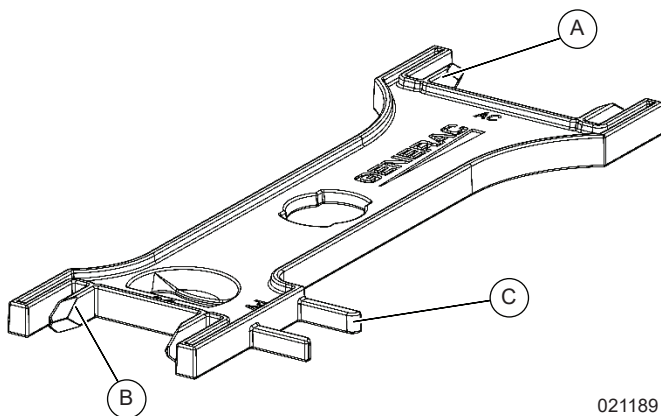

021189

Figure 4-11. PWRmicro Disconnect Tool

Observing PWRmicro Status LED

As soon as PV modules are connected to a PWRmicro inverter and exposed to sunlight, the green LED on the right side of PWRmicro will indicate microinverter status.

See [Table 4-5](#). The PWRmicro LED will blink at different intervals to indicate a specific status.

Table 4-5. PWRmicro LED Patterns

Interval	Description
Continuous blinking	DC connected, AC open ¹
1 blink every 16 seconds	Normal operation, inverter bound to Smart Combiner
1 blink every 8 seconds	Normal operation, inverter not bound to Smart Combiner
2 blinks every 4 seconds	Inverter phase-locked to grid, no export, no errors
3 blinks every 4 seconds	Inverter phase-locked to grid, Smart Combiner in reset
4 blinks every 4 seconds	Error: grid voltage out of range
5 blinks every 4 seconds	Error: DC voltage out of range
8 blinks every 4 seconds	Error: harmonic distortion

¹ If continuously blinking after AC applied, internal fuses may be open. Contact Generac Clean Energy Technical Support.

This page intentionally left blank.

Section 5: Mounting Smart Combiner

Mounting Guidelines

Use these general guidelines when mounting the Smart Combiner.

- Verify mounting location adheres to [Location Requirements](#).
- Smart Combiner must be mounted upright on a vertical wall.
- Observe all mounting clearances.
- Fasteners must adequately secure 29 lb (13.15 kg) Smart Combiner to the wall.
- Fasteners must be suitable for the mounting surface.
- Fasteners must engage at least two studs or other structural members.
- Install blocking or channel strut as needed.

Determining a Top Line

If mounting PWRmicro Smart Combiner on the same wall with other equipment, top-align the enclosures for best aesthetics. Otherwise, if mounting Smart Combiner on a separate wall space, mind unit dimensions and minimum clearances to establish an appropriate top line.

Proceed as follows to determine top mounting line:

1. See [Figure 5-1](#). Measure from the top line 4 in (10.16 cm) down to the top of the Smart Combiner mounting bracket and place a mark for reference.

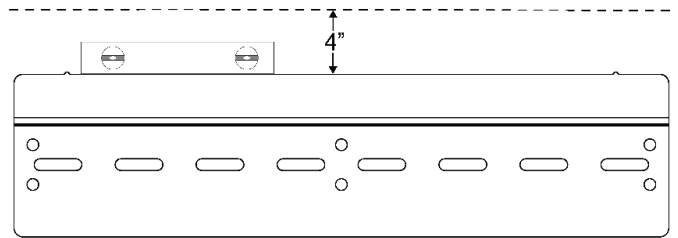

021215

Figure 5-1. Measuring from Top Line

2. Use a level on the bracket to mark holes.
3. Pre-drill holes as needed.

Fastening the Mounting Bracket

See [Figure 5-2](#). Once the bracket height and mounting holes have been marked on the mounting surface, fasten bracket to wall using appropriate fasteners.

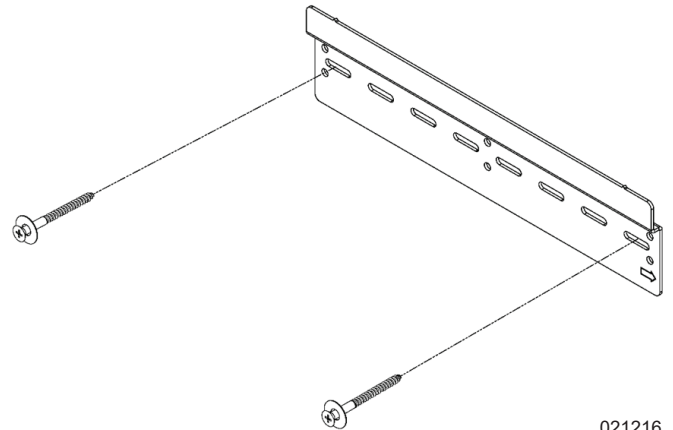

021216

Figure 5-2. Fastening the Mounting Bracket

Punching Conduit Holes

It may be advantageous to punch conduit holes in the Smart Combiner enclosure before hanging it on the wall. Depending on how close Smart Combiner will be mounted to other equipment, tool access may be limited. Hang Smart Combiner on the mounting bracket for a dry fit before securing.

For best results and to limit metal shavings, use a punch tool for the diameter conduit to be installed. Remove all metal shavings after punching conduit holes. See [Knockout Locations](#) for more information on where to punch holes in Smart Combiner.

Mounting and Fastening Smart Combiner

Proceed as follows to mount and fasten the Smart Combiner.

1. See [Figure 5-3](#). Hang Smart Combiner (A) on the mounting bracket (B). Leave Smart Combiner loose on the bracket to fit conduit in between it and other enclosures.

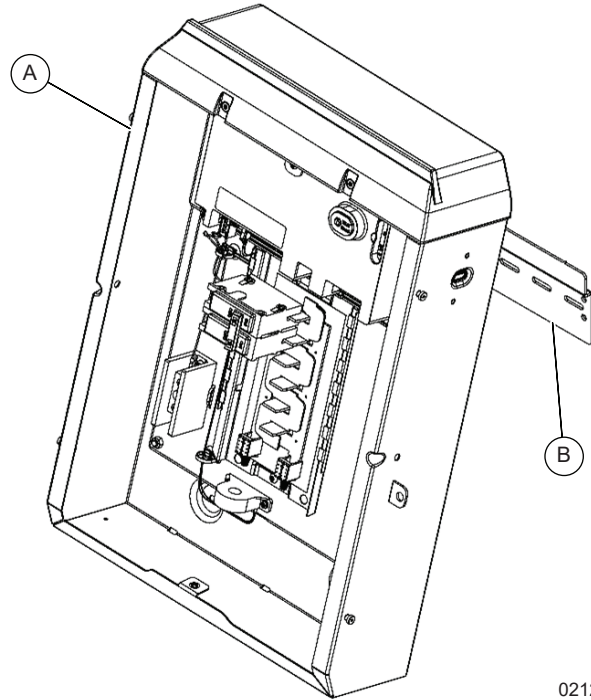

021217

Figure 5-3. Hanging Smart Combiner

2. See [Figure 5-4](#). Once conduit (if equipped) has been installed between Smart Combiner and other equipment, fasten the enclosure to the wall through the wiring compartment (C).

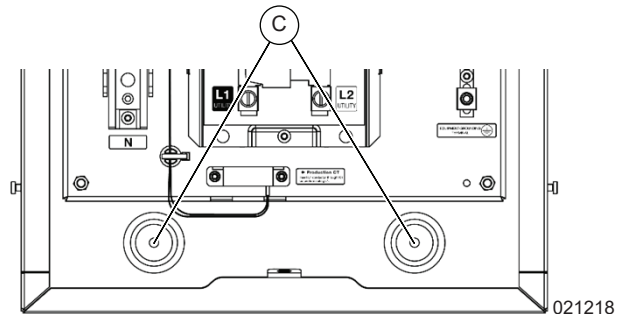

021218

Figure 5-4. Fastening the Enclosure to the Wall

Section 6: Wiring Smart Combiner

Wiring Guidelines



DANGER

Electrocution. Verify all system voltages are safe before wiring. Disconnect all AC sources of power before touching conductors or terminals. Failure to do so will result in death or serious injury.

(D000838)



DANGER

Electrocution. Turn off all parallel power sources, including feed from utility, before touching terminals. Failure to do so will result in death, serious injury, equipment, and property damage.

(D000837)

WARNING

Electric Shock. Only a trained and licensed electrician should perform wiring and connections to unit. Failure to follow proper installation requirements could result in death, serious injury, and equipment or property damage.

(W000155)

WARNING

Equipment damage. Only qualified service personnel may install, operate, and maintain this equipment. Failure to follow proper installation requirements could result in death, serious injury, and equipment or property damage.

(W000182)

- Smart Combiner shall be installed in accordance with NEC Articles 690, 705, and 750.
- Always use wiring methods in accordance with National Electrical Code (ANSI/NFPA 70) and other applicable codes.
- All field installed conductors are to be sized in compliance with NEC Article 310.
- Tighten all terminals as specified in this section.
- Install an appropriate initiation device for Rapid Shutdown compliance as needed. See [Rapid Shutdown](#).

Smart Combiner Wiring Compartment

See [Figure 6-1](#) for subsequent wiring instructions in this section.

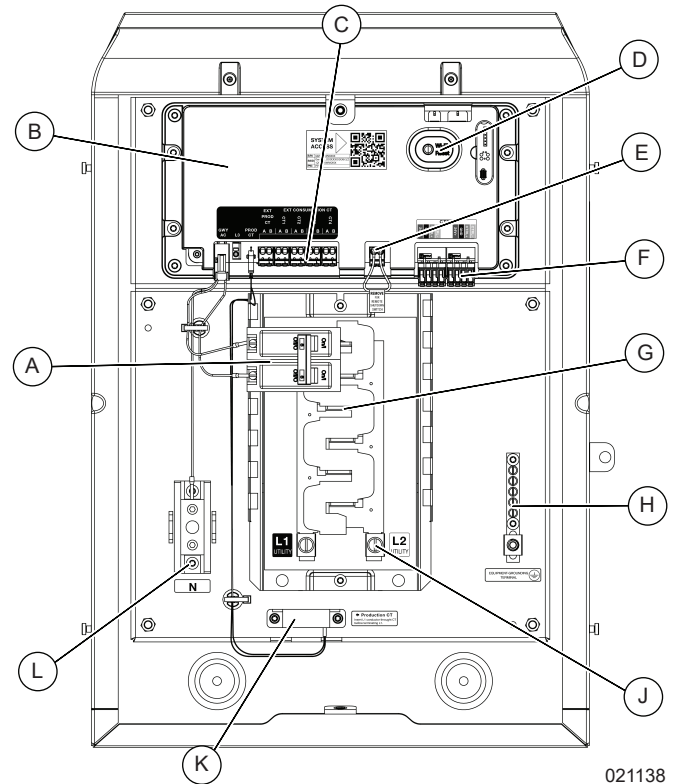

021138

Figure 6-1. Smart Combiner Wiring Compartment

A	Gateway/ Control Board Breaker	E	Not Used	J	Utility Connection
B	Control Board	F	CTRL Terminals	K	Production CT
C	External CTs Terminals	G	Panelboard Bussing	L	Neutral Lug
D	Wi-Fi Reset Button	H	Ground Bar		

Installing Circuit Breakers

Install up to five 2-pole AC PV circuit breakers in Smart Combiner.

NOTE: The maximum number of PWRmicro inverters allowed on one AC PV circuit is seven. Only install Eaton type BR breakers up to 30 A in Smart Combiner.

NOTE: Do not remove or relocate the 15 A breaker for the Smart Combiner Gateway and Control Board.

See [Table 6-1](#). For AC PV branch circuits in Smart Combiner install Eaton type BR breakers.

Table 6-1. AC PV Circuit Breaker Selection

Number of PWRmicros	OCPD	Eaton Breaker
1-3	15 A	BR215
4	20 A	BR220
5	25 A	BR225
6-7	30 A	BR230

Wiring PWRmicro Circuits

Proceed as follows to terminate AC PV circuits from PV array to Smart Combiner:

1. Route conductors for L1, L2, and Ground from PV array junction box (es) to Smart Combiner using copper wire type THHN, THWN-2, or NM, as appropriate for the application given the circumstances of the unique installation.
2. Use black wire for L1, red wire for L2, and green or bare wire for Ground. Otherwise, use phase tape to indicate phasing.
3. Terminate Ground at the Smart Combiner ground bar.
4. Terminate L1 and L2 at the appropriately sized Eaton type BR breaker for the AC PV circuit being terminated.

Interconnecting Smart Combiner

Proceed as follows to interconnect the PWRmicro system to the utility through the house main panel or Generac SDS:

1. Install an overcurrent protection device in the main panel, or Generac SDS, sized according to the PV array output current in accordance with the NEC for interconnection.
2. Route appropriately sized copper conductors for L1, L2, Neutral, and Ground from the main panel or Generac SDS to the Smart Combiner using wire type THHN, THWN-2, or NMC as appropriate for the application given the circumstances of the unique installation.

3. Terminate the ground conductor to the ground bar in Smart Combiner.
4. Terminate the neutral conductor to the neutral bar in Smart Combiner.
5. Terminate L1 and L2 to the L1 and L2 lugs at the bottom of the bus in Smart Combiner.

Tightening Connections

See [Table 6-2](#). Tighten all connections in Smart Combiner according to the table.

Table 6-2. Tighten Connections at Smart Combiner

Connection	Wire Size	Torque
Utility L1/L2		50 in-lb (5.65 Nm)
PV Circuit Breakers	SEE CIRCUIT BREAKER SPECIFICATIONS	
Neutral Lug	6–2/0 AWG	120 in-lb (13.56 Nm)
	8 AWG	40 in-lb (4.52 Nm)
	10–14 AWG	35 in-lb (3.95 Nm)
Lugs on Ground Bar	2/0 AWG	50 in-lb (5.65 Nm)
Ground Bar Terminals	4–6 AWG	35 in-lb (3.95 Nm)
	8 AWG	25 in-lb (2.82 Nm)
	10–14 AWG	20 in-lb (2.26 Nm)
USE AWG, RATED MINIMUM 194 °F (90 °C) COPPER CONDUCTORS ONLY		

External CTs

External CTs for consumption metering are included with Smart Combiner. Generac recommends installing these in every PWRmicro system. They are required for installations using PCS.

See [Figure 6-2](#). External CTs should be clamped around the service conductors above the point of interconnection and all house loads. If installing PWRmicro with PWRcell 2, connect external CTs to Generac Smart Disconnect Switch (SDS).

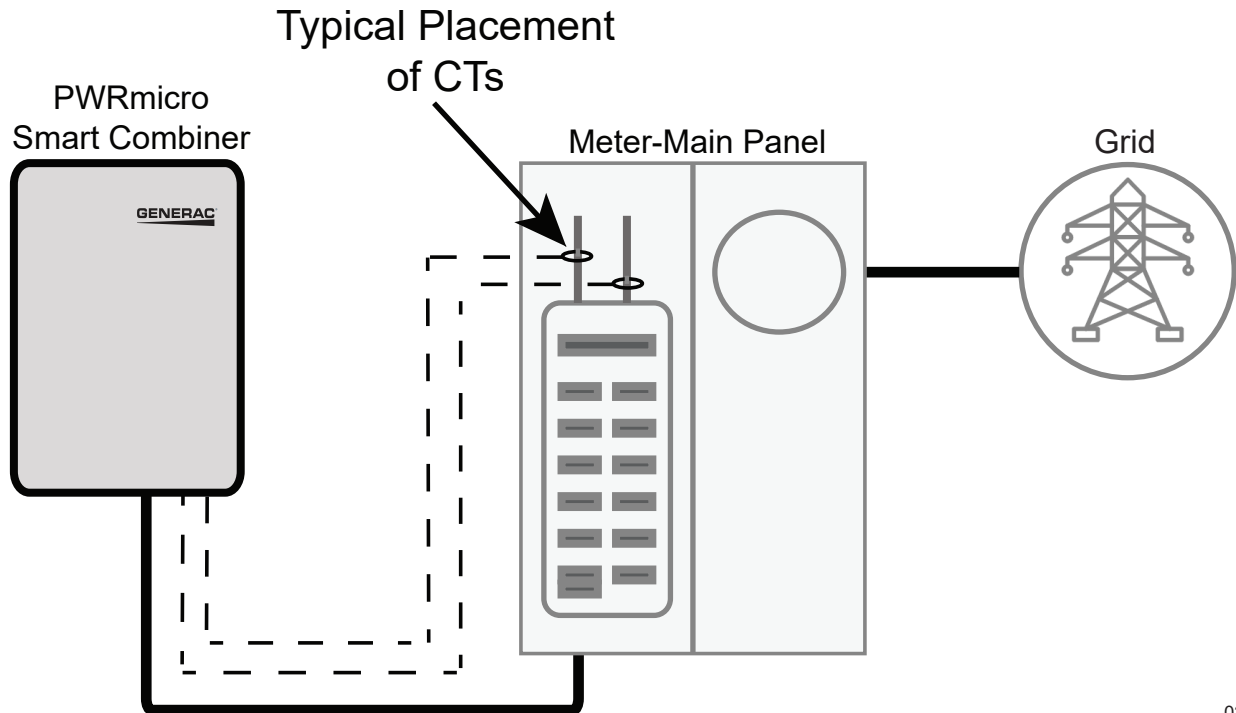

021143

Figure 6-2. Installing External CTs

Install External CTs



⚠ DANGER

Electrocution. Use caution when installing or servicing CTs around service conductors. Service conductors are live and voltage is present at main disconnect input terminals in main panel. Contact with live terminals will result in death or serious injury.

(D000826)

Proceed as follows to install external CTs:

1. Verify equipment is OFF.
2. Turn off main service disconnect.
3. See [Figure 6-3](#). Orient CTs so SOURCE THIS SIDE label is pointed toward the utility service.

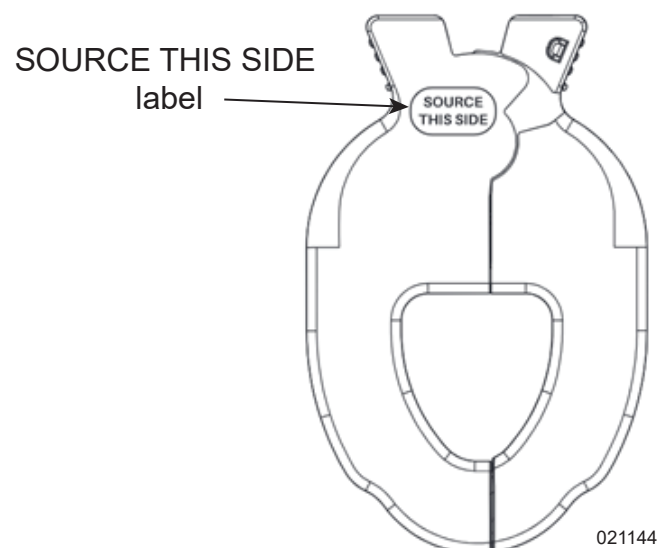

021144

Figure 6-3. SOURCE THIS SIDE Label

4. See [Figure 6-4](#). Clamp CT1 around the Line 1 service conductor and clamp CT2 around the Line 2 service conductor.

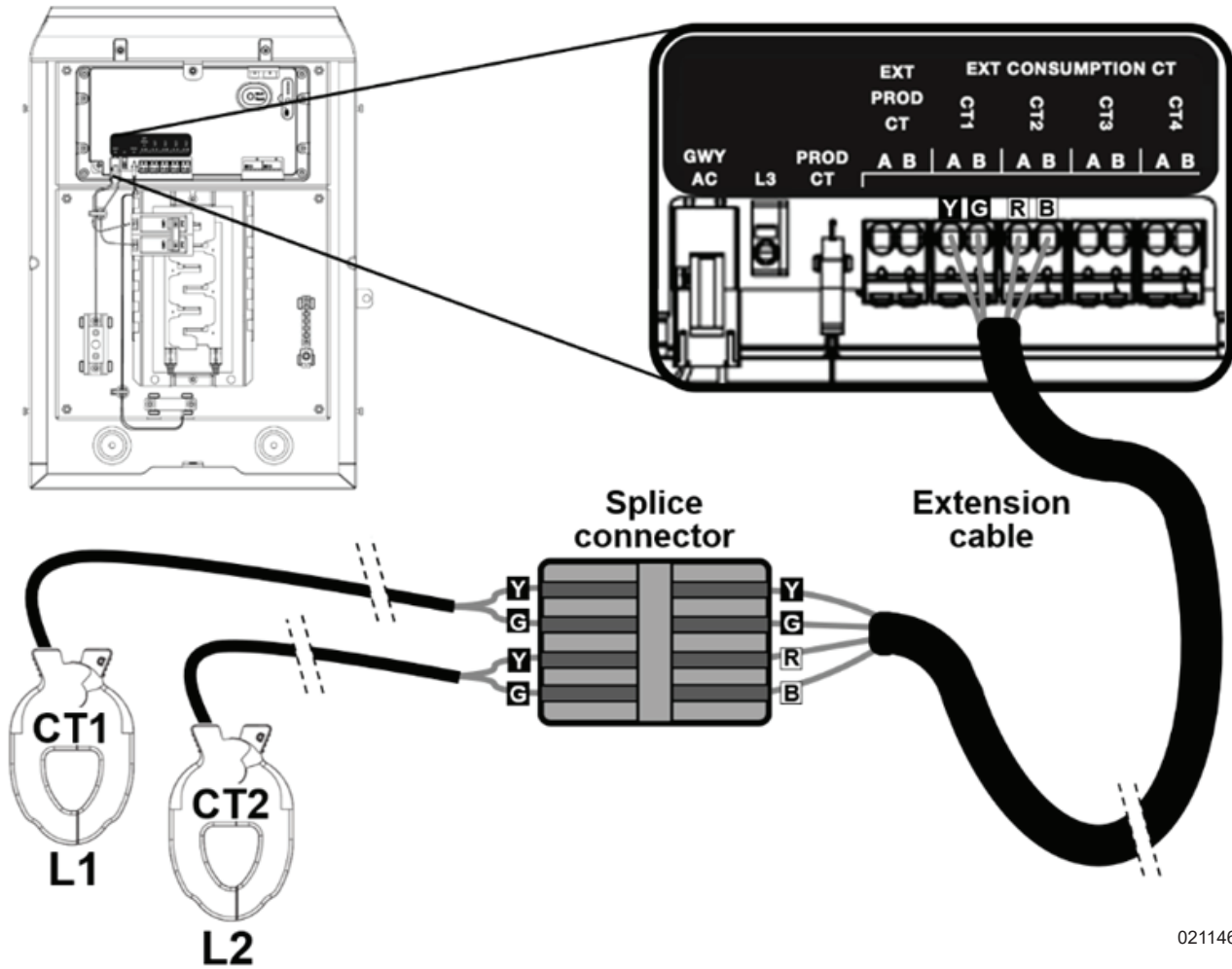

021146

Figure 6-4. Wiring External CTs to Smart Combiner

5. Connect CTs to extension cable inside of the main panel using the terminal block included in the package. Terminate CTs leads on one end and the extension cable on the other end. Match wire colors using the following:
 - CT1 A = yellow (Y)
 - CT1 B = green (G)
 - CT2 A = red (R)
 - CT2 B = black (B)

NOTE: If unable to install CTs on the service entrance conductors above the point of interconnection and all house loads, L1 and L2 branch circuit conductors may be bundled separately in each respective CT. If bundling branch circuit conductors, verify directionality of each conductor is consistent.

Control Wiring (if installing with PWRcell2)

Proceed as follows to connect the control circuit wiring if installing the PWRmicro system with PWRcell 2:

1. Ideally, position Smart Combiner in the CTRL circuit daisy chain between the PWRcell 2 Inverter and SDS (or between the PWRcell 2 Battery and PWRcell 2 Inverter).

NOTE: There must always be one termination resistor on either end of the CTRL circuit daisy chain. If Smart Combiner will be wired to one end of the chain, remove the pluggable termination resistor from SDS or the PWRcell 2 Battery and place in the open CTRL terminal position at Smart Combiner.

2. Use 600 Volt-rated #18 AWG shielded 4-conductor cable for the control circuit between all equipment.

3. Terminate red to 24 V, black to GND, orange to CTRL+, blue to CTRL-, from the PWRcell 2 Inverter to the left-hand CTRL terminals (A) on the Smart Combiner Control Board.
4. See [Figure 6-5](#). Terminate red to 24 V, black to GND, orange to CTRL+, blue to CTRL-, from SDS to the right-hand CTRL terminals (B) on the Smart Combiner Control Board.

NOTE: To avoid creating a ground loop, terminate drain wires for CTRL cables segments at one end of each segment only.

NOTE: If installing PWRmicro with PWRcell 2, follow instructions for installing AC PV in the Generac Smart Disconnect Switch Installation Manual. Terminate power conductors from Smart Combiner at the AC PV breaker location in SDS and terminate external CTs to SDS control board if external CTs are needed to monitor upstream loads or power sources.

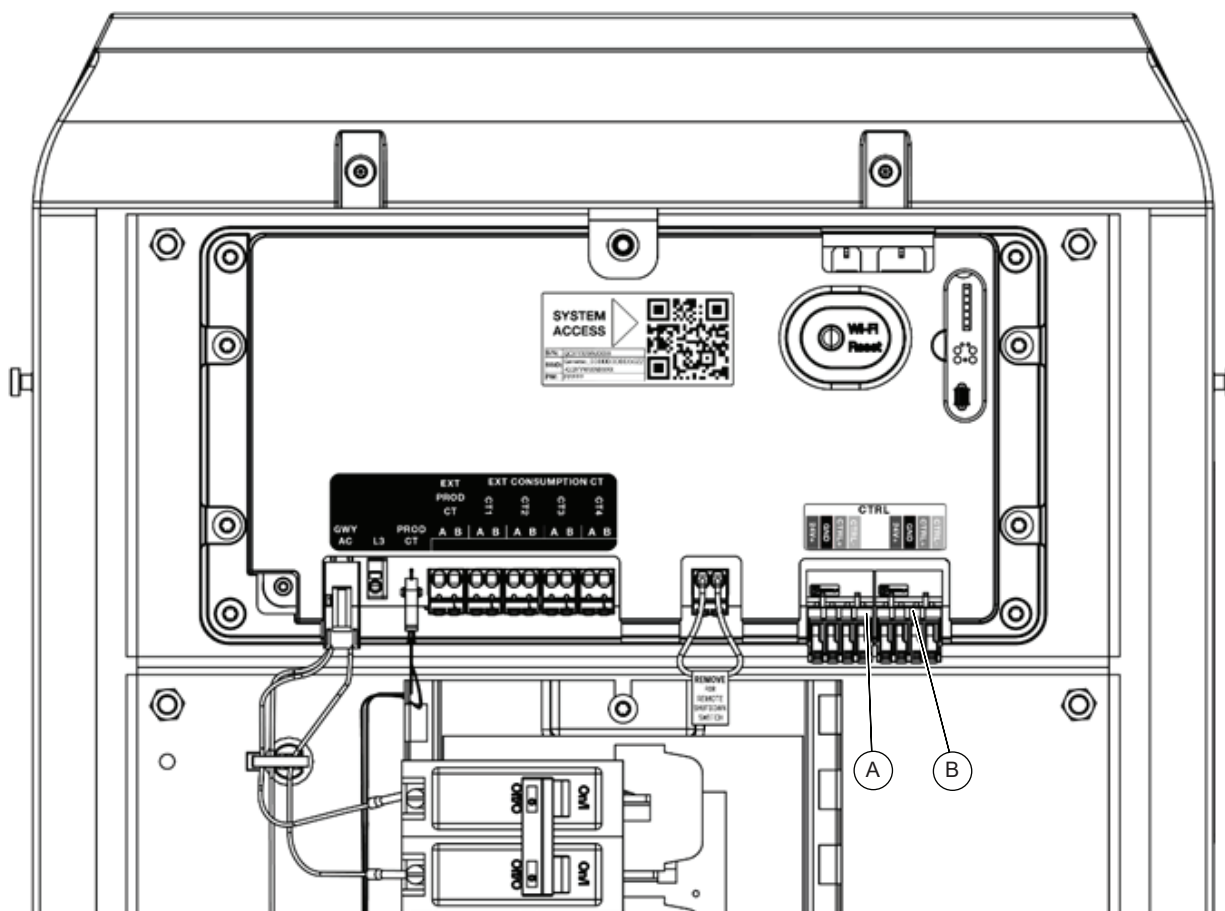

Figure 6-5. Terminating Control Wiring at CTRL Terminals

021278

This page intentionally left blank.

Section 7: Commissioning



DANGER

Electrocution. Verify electrical system is properly grounded before applying power. Failure to do so will result in death or serious injury.

(D000152)

Wiring Checks

Prior to commissioning:

1. Complete a visual inspection of the wiring at Smart Combiner.
2. Verify connections have been tightened according to specification and perform tug tests.
3. Use a multi-meter to check resistance on each circuit before energizing.
4. Verify phasing of AC wiring.

Accessing the Installer App

See [Figure 7-1](#). Commissioning the PWRmicro system is completed by accessing the local network emitted by the Smart Combiner. Download the Field Pro app on your mobile device and login with your company's PWRfleet credentials. Scan the QR code on the dead front of the Smart Combiner and follow the step-by-step instructions in Field Pro to commission the system.

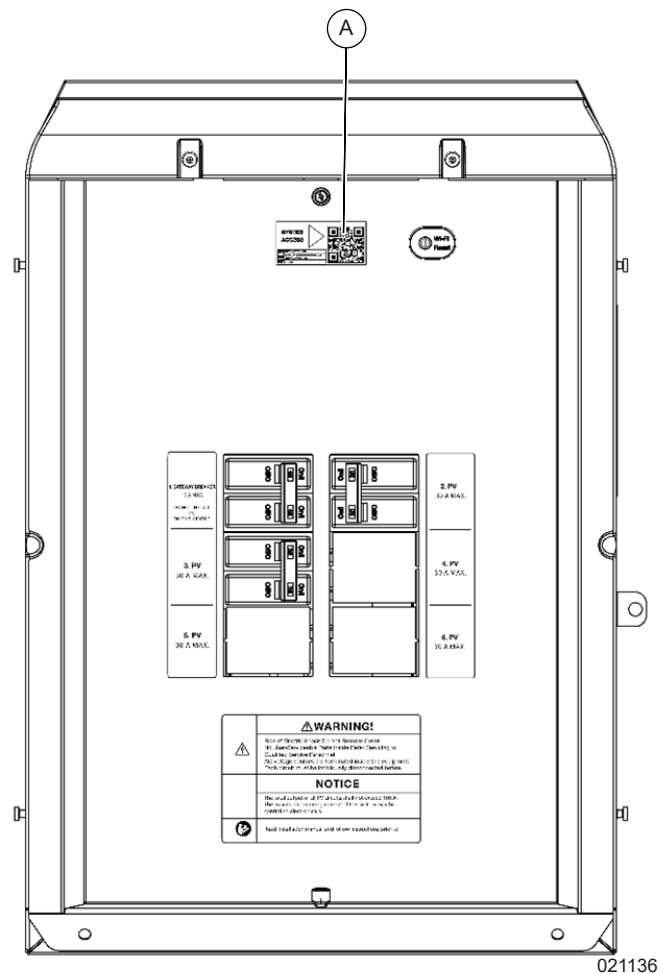

021136

Figure 7-1. Scanning the QR Code

This page intentionally left blank.

Section 8: System Operation



⚠ DANGER

Electrocution. Smart Combiner dead front cover should be removed by a qualified technician only. Improper removal of dead front cover will result in death, property damage, or serious injury.

(D000835)

⚠ WARNING

Equipment damage. Only qualified service personnel may install, operate, and maintain this equipment. Failure to follow proper installation requirements could result in death, serious injury, and equipment or property damage.

(W000182)

General Information

The PWRmicro system is composed of microinverters in the PV array which terminate in the Smart Combiner. The microinverters communicate with the Smart Combiner using power line communications (PLC) for module-level monitoring. Use the PWRview mobile app for system monitoring and performance details.

See [Figure 8-1](#). The only operable mechanical components for the PWRmicro system are the circuit breakers in the Smart Combiner and the Wi-Fi reset button. Turn Gateway breaker (A) OFF/ON to power cycle Gateway communication device in Smart Combiner. Turn PV breakers (B) OFF to shut down PV array. Use the Wi-Fi reset button as needed to reset the Smart Combiner Gateway.

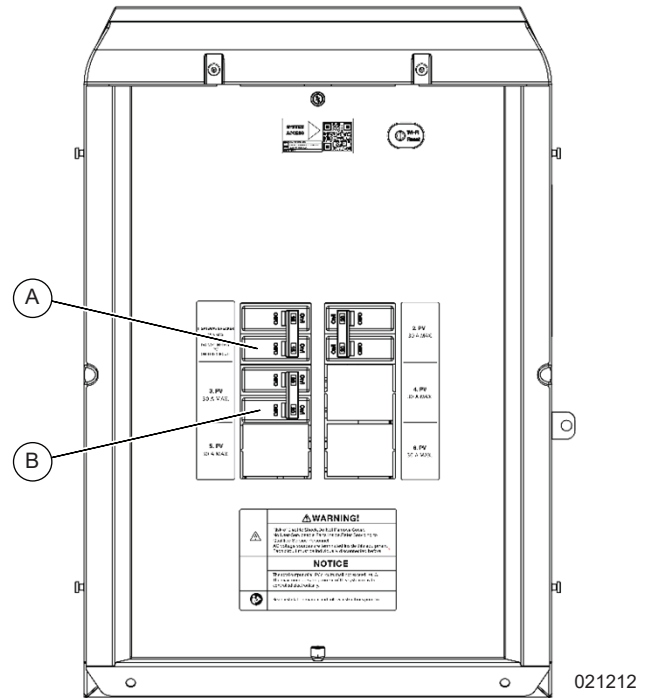

Figure 8-1. Operating Breakers in Smart Combiner

Smart Combiner Status LED

See [Table 8-1](#). The Smart Combiner Status LED indicates the status of the PWRmicro system, the Wi-Fi connection, and updates to system firmware.

Table 8-1. Smart Combiner Status LED

LED Color	Interval	Status
Green	Solid	Operating normally
Green	Blinking	PV system operating; no internet connection
Blue	Blinking	System firmware is updating
Red	Solid	System in error

This page intentionally left blank.

Section 9: Maintenance

Service



⚠ DANGER

Electrocution. Turn off all parallel power sources, including feed from utility, before touching terminals. Failure to do so will result in death, serious injury, equipment, and property damage.

(D000837)

⚠ DANGER

Arc Flash and Electric Shock. Do not attempt to unplug AC or DC connectors under load. Open PV breakers and render equipment inoperable before servicing. Failure to do so will result in death or serious injury.

(D000830)



⚠ WARNING

Electrocution. Potentially lethal voltages are generated by this equipment. Render the equipment safe before attempting repairs or maintenance. Failure to do so could result in death or serious injury.

(W000187)

⚠ WARNING

Electric Shock. Only a trained and licensed electrician should perform wiring and connections to unit. Failure to follow proper installation requirements could result in death, serious injury, and equipment or property damage.

(W000155)

⚠ WARNING

Equipment damage. Connecting inverter to electric utility grid must only be done after receiving prior approval from utility company. Failure to do so could result in equipment or property damage.

(W000640)

⚠ WARNING

Burns. Microinverter body is a heat sink and will be hot during and after operating. Shutdown microinverter and allow to cool before handling. Failure to do so could result in burns and serious injury.

(W000836)

IMPORTANT NOTE: There are no user serviceable parts inside microinverter. Do not attempt to open the unit.

For any servicing needs, contact the nearest Independent Authorized Service Dealer (IASD); contact Generac Technical Support at 1-855-635-5186; or call Generac Customer Service at 1-888-438-3722 (1-888-GENERAC); or visit www.generac.com.

This page intentionally left blank.

Section 10: Array Map

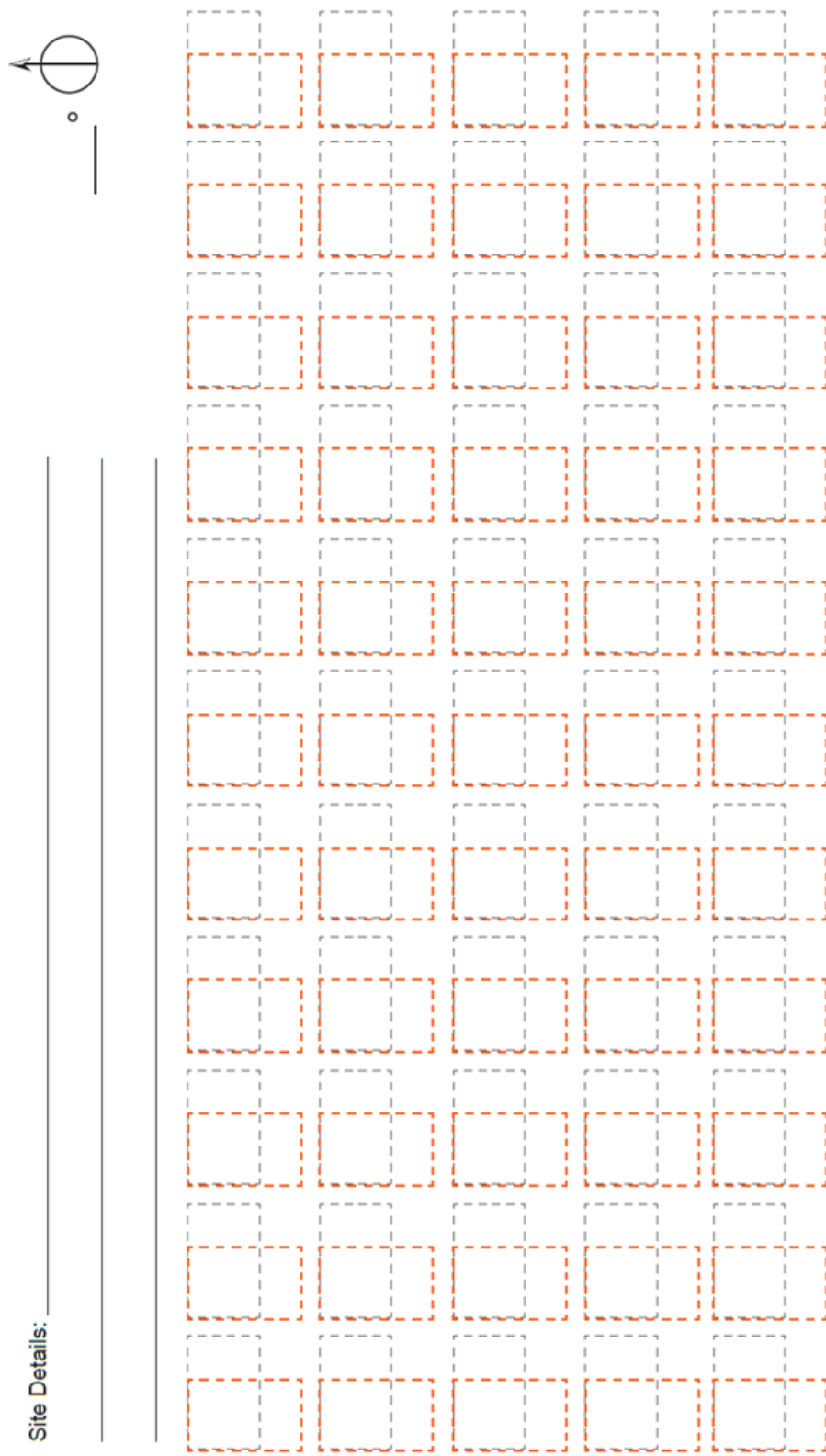

021213

This page intentionally left blank.

Section 11: Measurement and Calculation Accuracy

Table 11-1. Measurement and Calculation Accuracy^a

Parameter	Steady-State Measurements			Transient Measurements		
	Measurement Accuracy	Measurement Window	Range	Measurement Accuracy	Measurement Window	Range
Voltage, RMS	± 1.2 V (1%)	10 cycles	60 V - 144 V	± 2.4 V (2%)	5 cycles	60 V - 144 V
Frequency ^b	10 mHz	60 cycles	50 Hz - 66 Hz	100 mHz	5 cycles	50 Hz - 66 Hz
Active Power	± 41 W (5%)	10 cycles	164 W - 820 W	Not required	N/A	N/A
Reactive Power	± 41 var	10 cycles	164 var - 820 var	Not required	N/A	N/A
Time	1% ^c	N/A	5 s to 600 s	2 cycles	N/A	100 ms < 5 s

^a For voltage THD <2.5% and individual voltage harmonics <1.5%

^b For when the fundamental voltage is greater than 30% of the nominal voltage.

^c Percentage of measured duration.

This page intentionally left blank.

Section 12: Voltage and Frequency Trip Thresholds

PWRmicro is certified to UL 1741. This certification includes compliance with UL 1741 SA and UL 1741 SB for normal operating performance category B and abnormal operating categories II and III. UL 1741-SB certification demonstrates compliance with IEEE 1547-2018. A full list of the default parameter values is found in Appendix C.

If local electric utility requirements for smart inverters/ DERs specify non-default inverter settings (per the locally adopted grid standard), follow the steps in [Commissioning](#) to setup with the required grid settings by either selecting a grid profile or entering in custom settings when a profile with the required settings is not available.

NOTE: Use of grid profiles in compliance with local electric utility smart inverter requirements may exceed the tested range(s) and/or have default activation states for grid support functions conflicting with UL 1741-SB.

Voltage Trip

See [Table 11-1](#) for UL 1741-SB default voltage trip settings. Voltage Trip results in PWRmicro opening its connection from the grid for anti-islanding protection. Voltage trip activates an enter service delay time (300 seconds default) for reconnection to the grid so long as the electrical service remains within the enter service voltage and frequency ranges.

Frequency Trip

See [Table 12-1](#) for UL 1741-SB default frequency trip settings. All over frequency and under frequency trip conditions result in the PWRmicro opening its connection from the grid for anti-islanding protection. Frequency trip activates an enter service delay time (300 seconds default) for reconnection to the grid so long as the electrical service voltage remains within the enter service voltage and frequency ranges.

Table 12-1. Voltage Trip and Frequency Trip Default Settings (UL 1741-SB)

Voltage Trip			Frequency Trip		
Trip Function / Threshold	Voltage (% of nominal)	Clearing Time (s)	Trip Function / Threshold	Frequency (Hz)	Clearing Time (s)
OV2	120	0.16	OF2	62	0.16
OV1	110	13	OF1	61.2	300
UV1	88	21	UF1	58.5	300
UV2	50	2	UF2	56.5	0.16

This page intentionally left blank.

Section 13: Grid Support Functions

Grid Support Functions Parameter Values and Range of Adjustability

[Table 13-1](#) contains information about the default values and range of adjustment for the parameters of UL 1741 Supplement B Functions evaluated on the PWRmicro Inverter. Advanced Grid Support Functions are listed with

Parameter Labels in the order specified in IEEE 1547.1-2020 Annex B per IEEE 1547-2018. The default values below are implemented in the IEEE 1547-2018 PWRmicro grid profile. Grid Support Function default activation states are per IEEE 1547-2018 and not specified.

Table 13-1. Advanced Grid Support Functions: Parameter Values and Range of Adjustability

Grid Support Function / Funct. Abbr.	Parameter Label	Parameter Default	Parameter Range	Units	Comments
Volt-VAr / Q(V)					
	QV_REF	1.00	0.95 – 1.05	V p.u.	Per-unit voltage based on Nameplate Nominal Voltage.
	QV_VREF_OLRT	300.0	300.0 – 5000.0	s	Use of the Vref Adjustment time constant parameter to be specified by Local Area EPS Operator.
	QV_CURVE_V2	0.98	0.92 – 1.05	V p.u.	Per-unit voltage based on Reference Voltage (Vref).
	QV_CURVE_Q2	0	-0.44 – 0.44	VAr p.u.	Per-unit reactive power. Negative value indicates absorption.
	QV_CURVE_V3	1.02	0.95 – 1.08	V p.u.	Per-unit voltage based on Reference Voltage (Vref).
	QV_CURVE_Q3	0	-0.44 – 0.44	VAr p.u.	Per-unit reactive power. Negative value indicates absorption.
	QV_CURVE_V1	0.92	0.77 – 1.03	V p.u.	Per-unit voltage based on Reference Voltage (Vref).
	QV_CURVE_Q1	0.44	0 – 0.44	VAr p.u.	Per-unit reactive power. Negative value

Grid Support Function / Funct. Abbr.	Parameter Label	Parameter Default	Parameter Range	Units	Comments
					indicates absorption.
	QV_CURVE_V4	1.08	0.97 – 1.23	V p.u.	Per-unit voltage based on Reference Voltage (Vref).
	QV_CURVE_Q4	-0.44	-0.44 – 0	VAr p.u.	Per-unit reactive power. Negative value indicates absorption.
	QV_OLRT	5.0	1.0 – 90.0	s	Open Loop Response Time; Time in seconds.
Watt-VAr / Q(P)					
	QP_CURVE_P3_GEN	1.0	0.5 – 1	W p.u.	Per-unit rated active power output.
	QP_CURVE_P2_GEN	0.5	0.4 – 0.8	W p.u.	Per-unit rated active power output.
	QP_CURVE_P1_GEN	0.2	0.1 – 0.7	W p.u.	Per-unit rated active power output.
	QP_CURVE_Q3_GEN	-0.44	-0.44 – 0.44	VAr p.u.	Per-unit reactive power. Negative value indicates absorption.
	QP_CURVE_Q2_GEN	0	-0.44 – 0.44	VAr p.u.	Per-unit reactive power. Negative value indicates absorption.
	QP_CURVE_Q1_GEN	0	-0.44 – 0.44	VAr p.u.	Per-unit reactive power. Negative value indicates absorption.
	QP_OLRT	N/A	max. 10	s	Open Loop Response Time in seconds.
Volt-Watt / P(V)					
	PV_CURVE_V1	1.06	1.05 – 1.06	V p.u.	Per-unit nominal voltage.

Grid Support Function / Funct. Abbr.	Parameter Label	Parameter Default	Parameter Range	Units	Comments
	PV_CURVE_P1	N/A	fixed at 1.00	W p.u.	Per-unit rated active power output.
	PV_CURVE_V2	1.10	1.06 – 1.10	V p.u.	Per-unit nominal voltage.
	PV_CURVE_P2_GEN	0.1	0.1 – 1.0	W p.u.	Applicable only if inverter can only generate active power and not absorb power.
	PV_OLRT	10.0	0.5 – 60	s	Open Loop Response Time in seconds.
Overvoltage Trip / OV					
	OV2_TRIP_V	1.20	fixed at 1.2	V p.u.	Per-unit voltage based on Nameplate Nominal Voltage.
	OV2_TRIP_T	0.16	fixed at 0.16	s	Clearing time in seconds.
	OV1_TRIP_V	1.10	1.1 – 1.2	V p.u.	Per-unit voltage based on Nameplate Nominal Voltage.
	OV1_TRIP_T	13.0	1.0 – 13.0	s	Clearing time in seconds.
Undervoltage Trip / UV					
	UV1_TRIP_V	0.88	0.0 – 0.88	V p.u.	Per-unit voltage based on Nameplate Nominal Voltage.
	UV1_TRIP_T	21.0	2.0 – 50.0	s	Clearing time in seconds.
	UV2_TRIP_V	0.5	0 – 0.50	V p.u.	Per-unit voltage based on Nameplate Nominal Voltage.
	UV2_TRIP_T	2.0	0.16 – 21.0	s	Clearing time in seconds.
Overfrequency / OF					

Grid Support Function / Funct. Abbr.	Parameter Label	Parameter Default		Parameter Range	Units	Comments
	OF2_TRIP_F	62.0		61.8 – 66.0	Hz	
	OF2_TRIP_T	0.16		0.16 – 1000.0	s	Clearing time in seconds.
	OF1_TRIP_F	61.2		61.0 – 66.0	Hz	
	OF1_TRIP_T	300.0		180.0 – 1000.0	s	Clearing time in seconds.
Underfrequency / UF						
	UF1_TRIP_F	58.5		50 – 59	Hz	
	UF1_TRIP_T	300		180 – 1000	s	Clearing time in seconds.
	UF2_TRIP_F	56.5		50.0 – 57.0	Hz	
	UF2_TRIP_T	0.16		0.16 – 1000.0	s	Clearing time in seconds.
Frequency-Droop / P(f)						
	PF_DBOF	0.036		0.017 – 1.0	Hz	Single-sided deadband value.
	PF_DBUF	0.036		0.017 – 1.0	Hz	Single-sided deadband value.
	PF_KOF	0.05		0.02 – 0.07	N/A	Per-unit frequency change corresponding to 1 per-unit power output change.
	PF_KUF	0.05		0.02 – 0.07	N/A	Per-unit frequency change corresponding to 1 per-unit power output change.
	PF_OLRT	5		0.2 – 10.0	s	Open Loop Response Time in seconds.
Ramp Rate						
	IOUT_NOM	3.42 (240)	3.94 (208)	N/A	Aac	Output Current Rating (Aac).
	RAMPRATE_NOM	1		N/A	%I _r /s	Minimum Normal Ramp Rate (%I _r rated/sec).

Grid Support Function / Funct. Abbr.	Parameter Label	Parameter Default	Parameter Range	Units	Comments
	RAMPRATE_MAX	100	N/A	%I _r /s	Maximum Normal ramp-up rate (%I _r ated/sec).
	CURRENT_RANGE	1-100	N/A	%I _r ated	Output current range of Function (% I _r ated).
	RAMPRATE_ACCUR	3	N/A	%I _r /s	Ramp rated accuracy (% I _r ated/sec).
MRA					
	Voltage MRA	+/-1%	N/A	V _{rms}	Voltage.
	Frequency MRA	.01	N/A	Hz	Frequence.
	Time MRA	0.032 for < 5 s 1% setpt for > 5s	N/A	s	Time.
	Active Power MRA	+/-5% Srated	N/A	W	Active Power.
	Reactive Power MRA	+/-5% Srated	N/A	VAR	Reactive Power.

This page intentionally left blank.

This page intentionally left blank.

This page intentionally left blank.

This page intentionally left blank.

Part No. A0008718926 Rev. B 02/02/2026
© 2026 Generac Power Systems, Inc.
All rights reserved.
Specifications are subject to change without notice.
No reproduction allowed in any form without prior written
consent from Generac Power Systems, Inc.



Generac Power Systems, Inc.
S45 W29290 Hwy. 59
Waukesha, WI 53189
1-888-GENERAC (1-888-436-3722)
www.generac.com