

## MORNINGSTAR READYRAIL SYSTEM DRY CONTACT ACCESSORY

**INCLUDES:** ReadyRelay Block and (2) installed relays A and B.

### Installation and Operation Instructions

For the most recent manual revisions, see the version at: [www.morningstarcorp.com](http://www.morningstarcorp.com)

Use following URL to register Morningstar ReadyRelay:  
<https://www.morningstarcorp.com/product-registration>

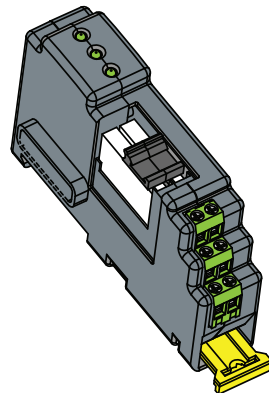

### DIMENSIONS [millimeters (inches)]

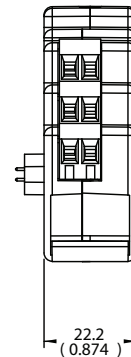
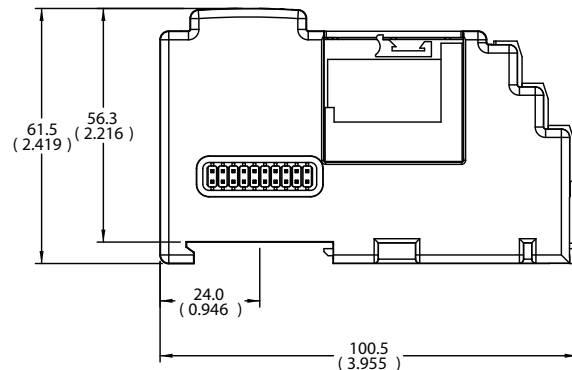
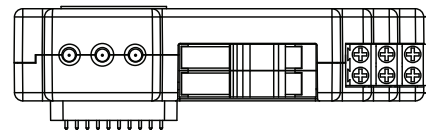

## TABLE OF CONTENTS

1.0 Safety Information.....	1
2.0 Overview.....	2
3.0 Installation.....	4
3.1 Mounting.....	5
4.0 Configuration.....	7
5.0 Wiring.....	11
5.1 General Use.....	12
5.2 Auto Genstart.....	12
5.2 Power-up.....	12
6.0 LED Indications and Troubleshooting.....	14
7.0 Warranty.....	15
8.0 Relay Specifications.....	17
9.0 Certifications.....	19

## 1.0 SAFETY INFORMATION



### **WARNING: Shock Hazard**

The Morningstar ReadyRelay must be installed by a qualified technician in accordance with the electrical regulations of the installation location.



### **WARNING: Shock Hazard**

Disconnect all power sources to the host and all other connected devices before working with ReadyRelay wiring. Do not install or remove a ReadyRelay while the host device is powered ON.



### **CAUTION: Equipment Damage**

The relay circuit has no overcurrent protection. A fuse no larger than six (6) Amps must be installed - in either leg - to protect the circuit. Since the internal relay circuitry has no overcurrent protection, the installer must ensure that the circuit is fused. ReadyRelay failures that result from lack of overcurrent protection are not covered by the Morningstar warranty.



### **CAUTION: Equipment Damage**

Power surges with in-rush current greater than 10 Amps can damage the relay.



## WARNINGS: Shock Hazards

Read all the instructions and cautions in the manual before starting the installation.

Beyond replacing the relays themselves, there are no user serviceable parts in the ReadyRelay Block. Do not disassemble or attempt to repair.

## 2.0 OVERVIEW and FEATURES

- The ReadyRelay requires a Morningstar ReadyRail™-enabled host device, e.g., GenStar controller or ReadyEdge System Monitor and Communication Center to provide a mounting surface, power, and programming capability.
- The ReadyRelay is an expansion block that adds AC or DC relay dry contact hardware functionality and firmware control and logic to the Morningstar GenStar MPPT charge controller.
- A ReadyRelay connected to the host device will automatically have its firmware updated with the host's ReadyRelay firmware version. For the latest battery support and features, ensure that the host device has been updated with the most current host device firmware.

### FEATURES:

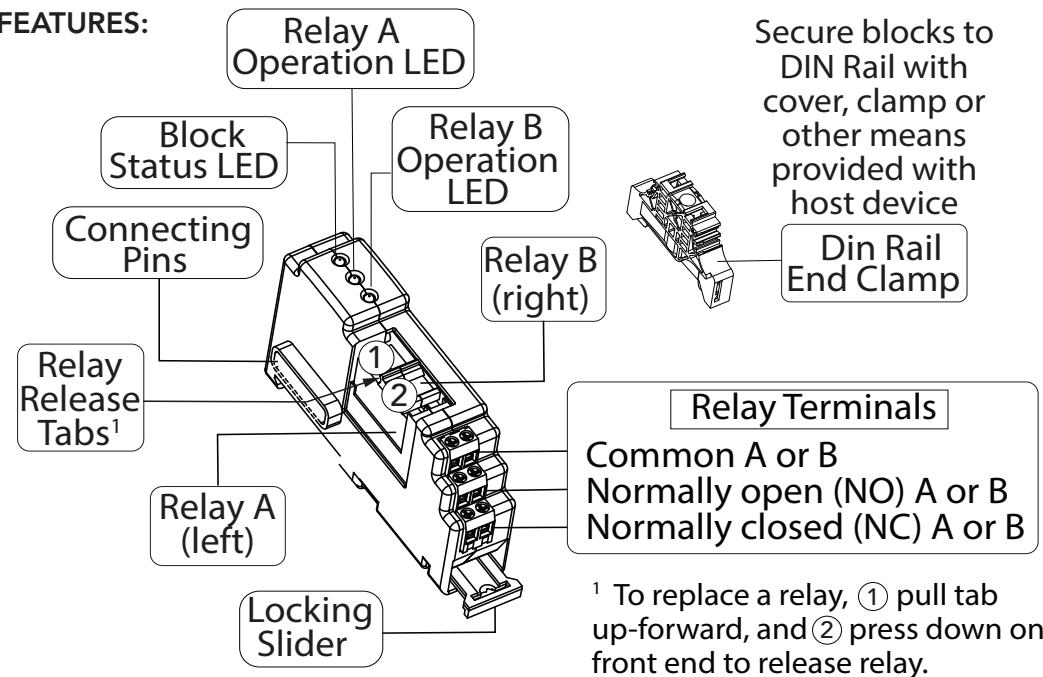

Figure 2-1. ReadyRelay Features

## 3.0 INSTALLATION

Morningstar ReadyRelays are DIN-Ready-rail-mounted, and have modular connectors on each side of the block. The left-side male connector mates with the host device female, while the right-side female connector is available for mating with another ReadyRelay (see Figure 1). Each ReadyRelay Block takes one available position on a DIN Rail - the left-most being Position 1.



### **WARNING: Shock Hazard**

*Do not install or remove a ReadyRelay while host device is powered ON. Always power OFF host device before working on ReadyRelay wiring.*



**CAUTION:** Host device configuration settings are made specifically for the Ready Block positions. Hence, if a Ready(Relay) block is moved, it has to be re-configured for the new position. Similarly, be aware that exchanging two ReadyRelays, e.g., between positions 1 and 2, might require re-configuration or re-wiring, because the settings for Position 1 will apply to any Ready Block installed in that position.

## 3.1 Mounting

The ReadyRelay is a modular accessory designed for installation onto a DIN-ReadyRail.

**To install ReadyRelays** (see Figure 3-1 below):

- 1) Power OFF host device. If applicable, remove Block cover and cut slot(s) for Block(s)
- 2) Pull yellow tab out
- 3) Fit Block slot downward onto DIN Rail
- 4) Slide the Block to the left, **but before** joining the male and female mates, be sure that pin guards and pins are lined up correctly. **Carefully** slide the Block farther to the left to securely join the Block with host-device female mates.
- 5) Push yellow tab in, to secure Block on rail
- 6) Secure Block(s) to DIN Rail with cover, clamp, or other means provided with host device.

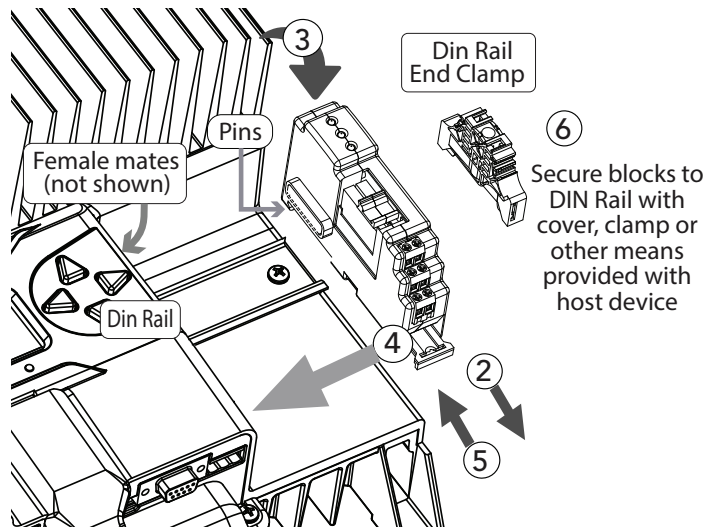

Figure 3-1. ReadyRelay Installation Detail

## 4.0 CONFIGURATION

*First connect the battery to the host device to power the host device-relay block system.*

Although the host device's meter layout (if present) closely resembles the Morningstar web interface - LiveView - webpages, only relay toggle commands can be made with the local meter display. Use one of the following methods to configure the Relay Block in LiveView:

1) With the host device connected to a PC, open a Web browser, and either:

A) Enter the host device IP address into the address bar, e.g.,  
<http://192.168.1.253>

The IP address can be found in the meter display in Settings\Network.

OR,

B) Enter the host device NetBIOS name [product abbreviation + 8-digit serial no.] into the address bar e.g. <http://GS21320850>. The NetBIOS name can be found in the meter display in Settings\Network.

2) Connect to a LAN using DHCP.



**CAUTION:** *Configure the ReadyRelay in the Morningstar LiveView webpage, **FIRST**, before wiring the relay.*

**Configure.** Once in LiveView, enter the installer's code - 141 - and then enable Installer Setup. Go to Ready Blocks. Any installed blocks will populate the ReadyRelay Configuration Box in the LiveView webpage. The location of each block is listed by positions 1-3, and relay A or B. Position 1 is the left-most block. Relay A is on the left, and relay B is on the right. Choose a block and relay to configure.

**Relay Function.** Choose how the relay will function: Threshold; Faults and Alarms; Charge Stage; External Source Control (ESC) Start-Stop; Command/Schedule. Each of the two Relay Block relays can be configured for a unique function:

1) **Threshold.** Choose whether the threshold will be reached from a rising or falling level; choose a variable, and then enter the desired ON and OFF thresholds, along with desired delays.

Activate ReadyRelays using Command buttons (after configuration in LiveView Installer ReadyRelay setup assignment).

2) **Faults/Alarms.** Activates a relay for optional devices when Block is programmed for specifically occurring fault conditions:

- A) When charging has stopped due to a fault
- B) When charging has stopped due to high battery voltage
- C) When Load has disconnected due to a fault
- D) When Load has disconnected due to high battery voltage
- E) An over temp alarm has occurred
- F) Charging current is being limited

3) **Charge Stage.** Toggles the relay for use with optional devices when the selected charge period - Bulk, Absorption, Float, Equalization, Night - is active. Further, relay start and exit delays can optionally be entered.

## 5.0 WIRING

4) **External Source Control (ESC) Start-Stop.** (A) Assign a relay to, "ESC Start-Stop" signal. (B) Go back to LiveView\Installer Setup\ESC, and program accordingly for desired Timing Controls and custom ESC schedules.

5) **Command/Schedule.** To allow a command to trigger relay activation (Ready Blocks\Relay Block ON), assign relay as, "Command/Schedule". Relays can also be scheduled for automatic operation.

**IMPORTANT:** To enable the use of Manual or Custom External Source Control Profiles, an ESC signal must be assigned to a relay (ReadyRelay Block).



**NOTE:** Proper generator/auxiliary equipment relay wiring is required - ReadyRelay terminal connections are indicated in Figure 1 on page 3.



**WARNING: Shock Hazard**

Disconnect all power sources to the host and all other connected devices before working with ReadyRelay wiring. Do not install or remove a ReadyRelay while the host device is powered ON.



**WARNING: Shock Hazard**

Wire sizing and load overcurrent protection devices must conform to NEC or other jurisdictional requirements.



**CAUTION: Equipment Damage**

Incorrect installation or configuration may result in damage to the generator and/or other system components.



**CAUTION:** External Source Control, e.g., generator control should only be configured and installed by experienced electrical professionals.



**CAUTION: Equipment Damage**

Incorrect installation or configuration may result in damage to the generator and/or other system components.

## 5.1 General Use

Relay contact terminals can be wired to a generator starting circuit, vent fan, communications equipment, larger relays for power switching, buzzer or trouble light (no auxiliary devices included).

After wiring, tighten the terminal connector screws to 5 in-lb (0.56 N-m) of torque.

## 5.2 External Source Control (ESC)

The external source, e.g., generator must be an electric-start model with automatic choke. It is recommended that the generator have two-wire start capability. Consult the generator manufacturer's autostart instructions for two-wire start generators.

A two-wire starting generator generally automates the cranking and starting routine. The Relay Common and Normally Open (NO) terminals can be wired to perform a two-wire generator start - see Figure 5-1 below.

## 5.3 System Power Up

**Connect the battery to the host device to power the host device-relay block system.**

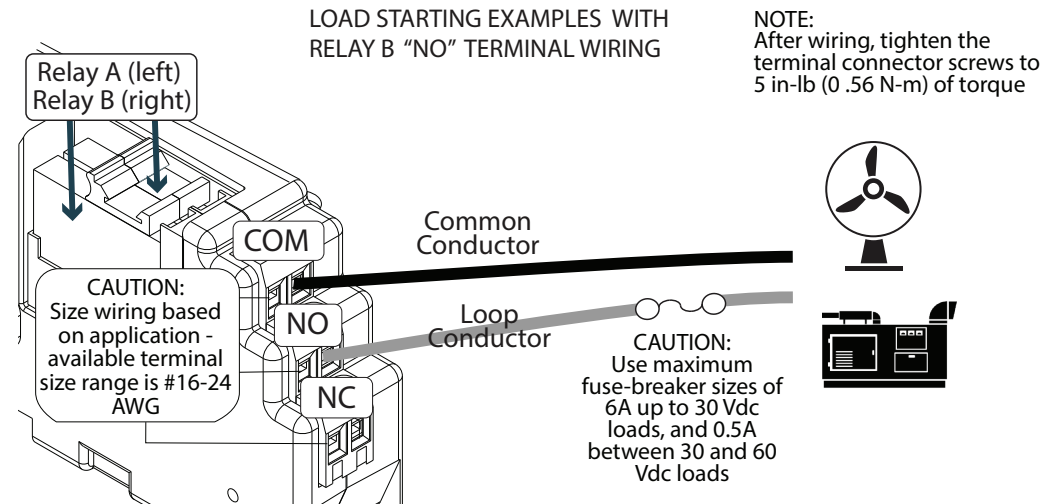

Figure 5-1 - Load Starting Detail



## 6.0 LED INDICATIONS and TROUBLESHOOTING

See Figure 2-1 in Section 2.0, and table below. The top ReadyRelay LED indicates Block status; the middle LED indicates operation of Relay A; the lower LED indicates operation of Relay B. The status LED will operate with a momentary heartbeat off every (5) seconds.

Status LED	Indication
Block not powered or could not start	OFF
Normal condition - no faults	Green solid
Block faulted	Red solid
Powered pre-boot	Red solid

Relay A or B LEDs	Indication
Relay open	OFF
Relay closed or closing	Green solid
Relay fault	Red solid

## 7.0 WARRANTY

### LIMITED WARRANTY - Morningstar Solar Controllers and Inverters

All Morningstar *Professional Series*<sup>™</sup> products, except the SureSine<sup>™</sup> inverter, are warranted to be free from defects in materials and workmanship for a period of FIVE (5) years from the date of shipment to the original end user. Warranty on replaced units, or field-replaced components, will be limited only to the duration of the original product coverage.

Morningstar *Essentials Series*<sup>™</sup>, and SureSine<sup>™</sup> inverter, products are warranted to be free from defects in materials and workmanship for a period of TWO (2) years from the date of shipment to the original end user. Warranty on replaced units, or field-replaced components, will be limited only to the duration of the original product coverage.

Morningstar will, at its option, repair or replace any such defective units.

### WARRANTY EXCLUSIONS AND LIMITATIONS

This warranty does not apply under the following conditions:

- Damage by accident, negligence, abuse or improper use

- PV or load currents exceeding the ratings of the product
- Unauthorized product modification or attempted repair
- Damage occurring during shipment
- Damage resulting from acts of nature such as lightning, weather extremes or infestation

THE WARRANTY AND REMEDIES SET FORTH ABOVE ARE EXCLUSIVE AND IN LIEU OF ALL OTHERS, EXPRESS OR IMPLIED. MORNINGSTAR SPECIFICALLY DISCLAIMS ANY AND ALL IMPLIED WARRANTIES, INCLUDING, WITHOUT LIMITATION, WARRANTIES OF MERCHANTABILITY AND FITNESS FOR A PARTICULAR PURPOSE. NO MORNINGSTAR DISTRIBUTOR, AGENT OR EMPLOYEE IS AUTHORIZED TO MAKE ANY MODIFICATION OR EXTENSION TO THIS WARRANTY.

MORNINGSTAR IS NOT RESPONSIBLE FOR INCIDENTAL OR CONSEQUENTIAL DAMAGES OF ANY KIND, INCLUDING BUT NOT LIMITED TO LOST PROFITS, DOWN-TIME, GOODWILL OR DAMAGE TO EQUIPMENT OR PROPERTY.

R15-1/20

## 8.0 RELAY SPECIFICATIONS

### **Electrical:**

Self-consumption:	< 0.2 W
Rated Switching Voltage	250 Vac / 60 Vdc
Maximum Switching Voltage	400 Vac
Rated Current	6.0 A (250 Vac) 6.0 A (30 Vdc) 200 mA (110 Vdc) 120 mA ( 220 Vdc)
Peak Current	10 A (250 Vac)
Minimum Switching Load	50 mW
Relay type	SPDT
Contact Operate / Release Time	5 / 3 msec
Number of Dry Contacts	2

### **Mechanical:**

Case	Plastic
------	---------

Terminations / Connectors  
Terminal Wire Range  
DIN-Rail Mount - Standard  
Enclosure Rating  
Weight

Compression  
24 - 14 AWG  
35 mm  
IP 20; Type 1; Indoor  
~3 Ounces (93 grams)

**Environmental:**

Operating Temperature  
Storage Temperature  
Altitude  
Humidity

-40°C to +60°C  
-40°C to +80°C  
3000 Meters  
100%  
non-condensing

Relay replacement part number:  
Contact Configuration:

34.51.7.012.5010  
SPDT

Full data sheet for relay 34.51.7.012.5010:  
<https://www.finder-relays.net>

**9.0 CERTIFICATIONS**



**FOR CURRENT DETAILED CERTIFICATION LISTINGS, REFER TO:**

<https://www.morningstarcorp.com/support/library>

**Under, "Type", choose, "Declaration of Conformity (DOC)", to view list of product DOCs.**

ReadyRelay and Meterbus™  
Morningstar Corporation

MODBUS™ and MODBUS TCP/IP™ are trademarks of Modbus  
IDA.

©2022 Morningstar Corporation. All rights reserved.