

COTEK

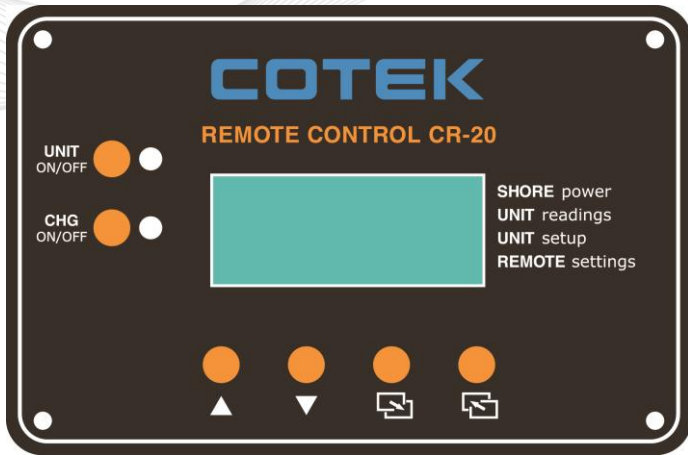

CR Series User's Manual

CR-20 Remote Control

1.0 Overview

CR-20 is a remote control designed for connecting to SL inverter/charger.

The package is including:

- (1) CR-20
- (2) 1.5m Cable
- (3) User Manual

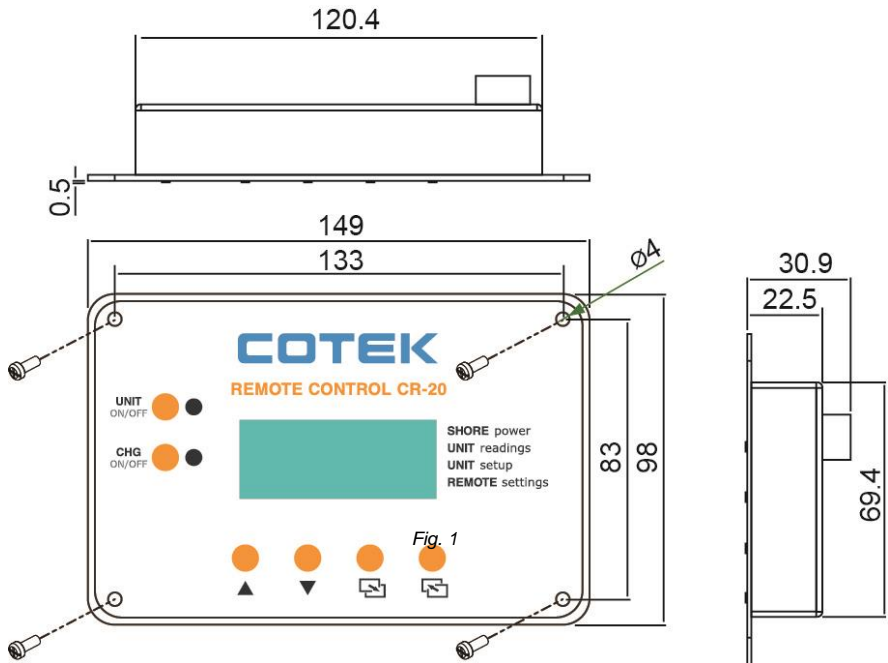

Fig. 1 (Unit: mm)

The CR-20 is equipped with the following features :

1.1 LED Indicators

The LEDs provide the inverter/charger statuses in a straightforward way.

1.2 LCD Display:

LCD Display - The LCD display is a 16 x 4 line alphanumeric display used for setting up the inverter/charger operation , as well as viewing current status or fault messages.

1.3 ON/OFF Pushbuttons (x2)

To turn on/off inverter or charger quickly.

1.4 Buttons

Pressing buttons allows you to select a menu item or to save a setting, once it is displayed on the LCD screen.



WARNING: Turning the unit OFF does not mean to disconnect the batteries or AC Power Source. Therefore the “AC output load” is still active.



WARNING: Only use the remote control cable supplied, using different cables could cause permanent damage to the SL inverter unit

2.0 Installation

2.1 Installation Guidelines

- Please determine the remote cable route throughout the home or vehicle/boat, both to and from the inverter before connecting any wires.
- Always check for existing electrical, plumbing, or other areas of potential damage before drilling or cutting into walls to mount the remote.
- Make sure all wires have a smooth bend radius and do not become kinked.
- Please ensure the conductors passing through walls, bulkheads, or other structural members are protected. This minimizes insulation damage such as chafing, which can be caused by vibration or constant rubbing when installing this remote in a boat, RV, or truck.

2.2 Installation Overview

The remote is required in order to connect the inverter/charger. Each inverter/charger must be connected directly to the remote using the supplied RJ11 communication cables.

The remote must be located close to the inverter/chargers within 25 meters and acts as the system control panel.

2.3 Mounting the Inverter

- Select an appropriate location to install the remote.
- Mount the remote base to the wall using the 4 screws provided.

Please refer to Fig. 1

2.4 Connecting the RJ-11 Cables

Please use RJ-11 cable supplied with remote to connect to inverter/charger.

See below indication.

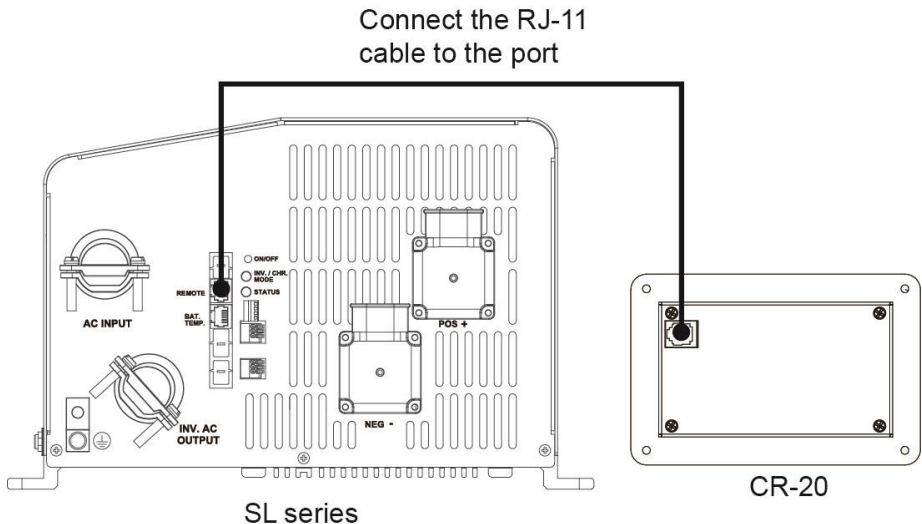

Fig. 2

3.0 Introduction

3.1 Front Panel

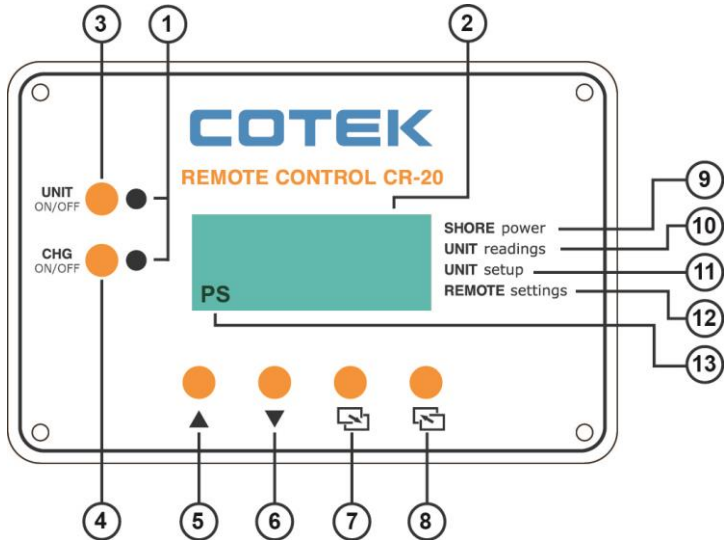

Fig. 3

1	LED Indicators - There are two LED indicators on the front panel that light solid to indicate the UNIT ON/OFF and CHG ON/OFF status.
2	LCD Display - The LCD display is used for setting up the system operation, as well as viewing current operating status and fault conditions.
3	UNIT ON/OFF Button - When user presses it, the remote and machine could work then remote must communication to machine.
4	CHG ON/OFF Button - This button toggles the charger function on and off whenever the charger is actively charging. The green CHG LED turns on and off with this button.
5	Up Button – move up in the menu tree.
6	Down Button – move down in the menu tree.
7	Enter Button – Go forward to the next page.
8	Back Button – Go back to previous page.

9	SHORE power - Set Inverter max current.(see 4.1)
10	UNIT readings - This item show DC · Temperature · AC INPUT and VAC OUT, FAULT condition. (see 4.2)
11	UNIT setup - Setting inverter parameter. (see 4.3)
12	REMOTE settings - Setting remote parameter. (see 4.4)
13	Operation mode indicator – indicate Power Share · INV · CHG mode

4.0 CR-20 Menu Maps

4.1 SHORE power.

4.2 Select SHORE power and press Enter Button as below frame.



4.3 UNIT readings.



4.4 UNIT setup.

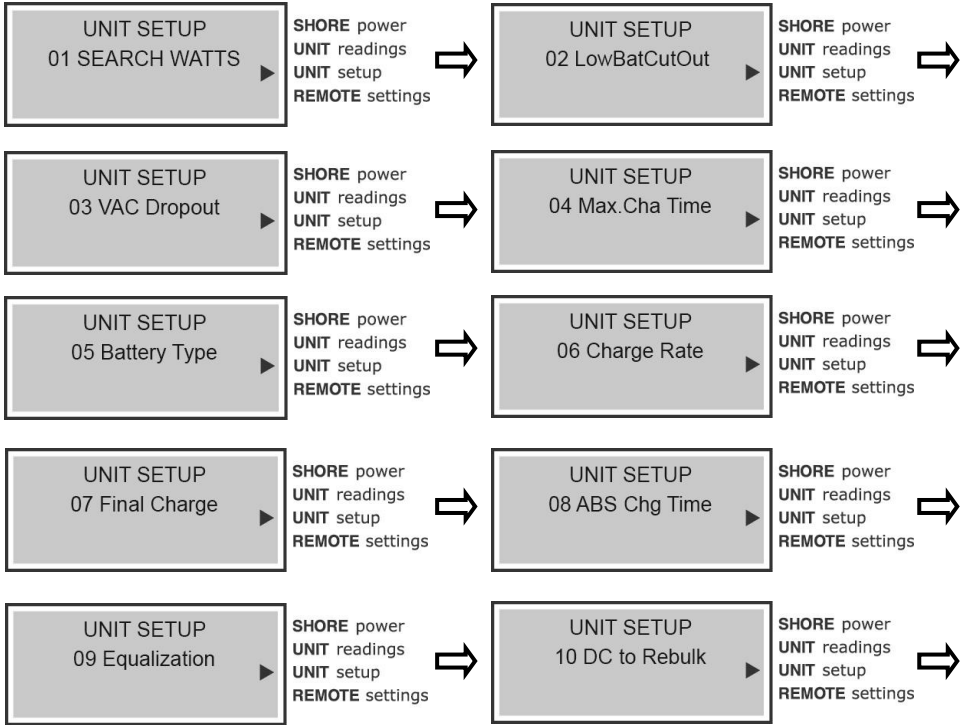

4.5 REMOTE setting.

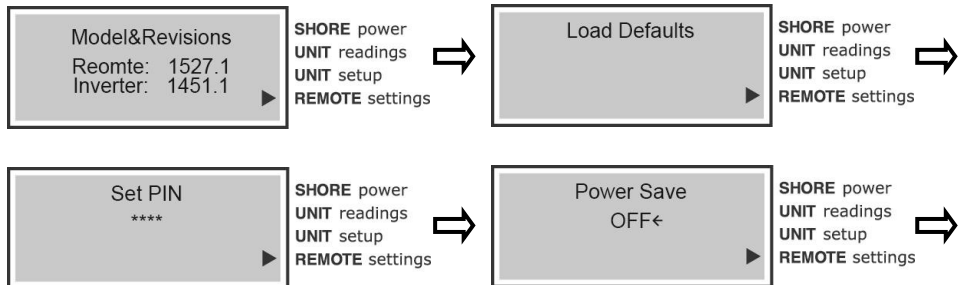

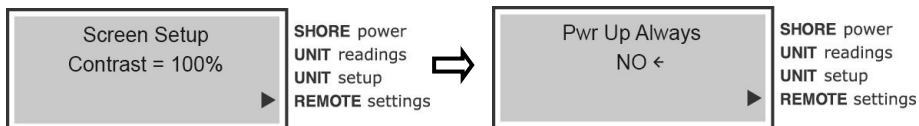

5.0 System Status Messages

5.1 UNIT./CHG LED indicator

	UNIT ON/OFF	CHG ON/OFF
Soild Green	Normal	CHG mode ON
Blink Green	Bypass	
Soild Red	Error	
NO Light		CHG mode OFF

6.0 Warranty

We guarantee this product against defects in materials and workmanship for a period of 24 months from the date of purchase and will repair or replace any defective Combi units if you directly returned them to us with postage paid.

Please note that Cotek is only responsible for ensuring our products are operational before delivering. This warranty will be considered void if the unit has been misused, altered, or accidentally damaged. Cotek is not liable for anything that occurs as a result of the user's fault.

COTEK

No.33, Sec. 2, Renhe Rd., DaxiDist., Taoyuan City 33548, Taiwan

Phone : +886-3-3891999 FAX : +886-3-3802333

http : // www.cotek.com.tw

2017.09._A0