

Reverse connection and Inrush protections

Rugged and reliable construction

Ultra-quiet, low EMI operation

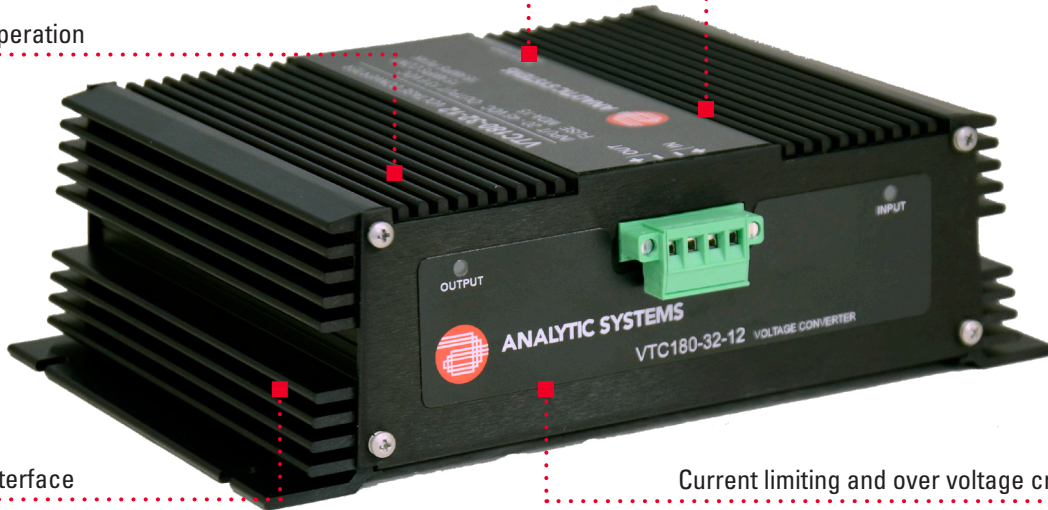

Simple and intuitive interface

Current limiting and over voltage crowbar protection

VTC 180
DC SOURCE VOLTAGE CONVERTER

The VTC180 series variable duty cycle switching Voltage Converter is designed to supply your devices with up to 180 watts of precision power. This model can be configured to run from a 24V, 32V, 48V or 72 V DC source to provide either 12V or 24V output. This unit's ultra-quiet low EMI operation makes it ideal for powering sensitive radio frequency communications equipment.

Designed for the sure and steady operation, the VTC180 series Voltage Converter features a multitude of safety features including reverse input connection protection, current limiting, output over-voltage protection, and inrush current protection.

In addition to these standard features, the VTC180 can optionally be built with military-grade vibration protection with an expanded operating temperature range for increased functionality in rugged environments.

We are confident that you will get many years of reliable service from this Voltage Converter.

3 YEAR WARRANTY



Available models

Input

32V

48V

72V

Output

12V

24V

Applications



VTC180 | DC SOURCE VOLTAGE CONVERTER

INPUT

Nominal Voltage	32 VDC	48 VDC	72 VDC
Actual Voltage	20-45 VDC	40-65 VDC	65-100 VDC
Input Amps (Max)	13.6 A	6.8 A	4.3 A
Input Fuse (MDA)	15 Amp	10 Amp	5 Amp
Noise on Input	< 50 mV		

OUTPUT

Nominal Voltage	12 VDC	24 VDC
Actual Voltage	13.6 ± 0.05 VDC	27.2 ± 0.05 VDC
Output Amps	15 A (Continuous) / 18 A (Peak)	7.5 A (Continuous) / 9 A (Peak)
Over-Voltage Crowbar	16.0 ± 0.5 V	32.0 ± 0.5 V
Ripple and Noise	< 10mV	
Transient Response	<1V for 50% Surge	
Regulation (Line and Load)	< +/- 0.5%	
Duty Cycle	Peak: 120% for 10 minutes maximum per hour Continuous: 100 % for 24 hours per day	
Efficiency	> 90% @ Maximum Output	

MECHANICAL

Length	7.9 in / 20.1 cm
Height	2.4 in / 6.1 cm
Width	6.0 in / 15.2 cm
Clearance	1.0 in / 2.5cm all around
Weight	4.0 lb / 1.9 kg
Material and Finish	Marine Grade Aluminum
Finish	Black Anodized
Fasteners	18-8 Stainless Fasteners
Connections	DC Input and Output – Phoenix 4-pin Terminal Block Connector

ENVIRONMENTAL AND SAFETY

Operating Temperature Range	-25°C to +40°C @ Maximum Output (Optional -40°C to +55°C extra wide operating temp. range available)
Humidity	0 - 95% relative humidity (non-condensing) with standard conformal coating
Isolation	Input-Case: 1500VDC (500 VDC on 32V Input models) Output-Case: 500 VDC Input-Output: Common Negative
Audible Noise	None, ØdB @ 3 feet / 1 meter
Typical Service Life	> 10 years (87,600 hrs)
Warranty	Three years parts and labor

OPTIONS

Open Frame - Built with no chassis

Heavy Duty Ruggedization - Expanded operating temperature and vibration protection

Encapsulated - Potted in polyurethane

ROHS - European ROHS complaint; lead-free manufacturing

DIMENSIONS

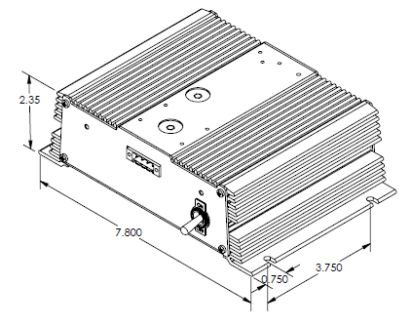
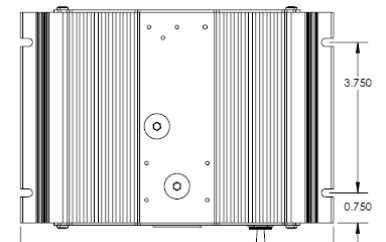
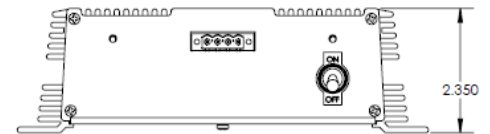

ANALYTIC SYSTEMS
Power Conversion Solutions



AnalyticSystems.com



sales@analyticsystems.com



604.946.9981 800.668.3884



8128 River Way
Delta, BC V4G 1K5