

# **AIRPAX**

## **DIMENSIONS**

Airpax Dimensions, Inc.  
4467 White Bear Parkway  
St. Paul, MN 55110-7626

(651) 653-7000  
Fax (651) 653-7600

**121139C**

**OWNERS MANUAL**

**JANUARY 2007**

ISO 9001:2000 Certified Company



## **Airpax Dimensions, Inc.**

### **DC to AC Power Inverters**

OWNERS MANUAL for Models:

**12/800N**  
**12/1200N**

# OWNERS MANUAL FOR AIRPAX DIMENSIONS INVERTERS

Model ADI-12/800N  
Model ADI-12/1200N

## Table of Contents

	<u>Page</u>
1. General . . . . .	2
2. Description . . . . .	2
3. Installation . . . . .	2
4. Start Up/Operation. . .	4
5. Troubleshooting. . . . .	4
6. Installation Figure 1 . .	5
7. Limited Warranty . . . . .	6

### 1. GENERAL

**1.01** Dimensions inverters have been designed and manufactured for many user applications and long life. They utilize patented construction methods and high technology electronic parts and circuitry.

**1.02 CAUTION:** Inverters produce hazardous voltages, to avoid risk of harm or fire the unit must be properly installed. There are no user serviceable parts inside, do not remove the cover.

*CAUTION:* The inverter should not be mounted in a location that may be exposed to rain or spray.

*CAUTION:* The inverter should not be installed in a zero clearance enclosure.

*CAUTION:* Damage to the inverter will occur if correct polarity is not observed when installing the DC input cables.

*CAUTION:* Damage to the inverter will occur if an external AC power source is applied to the inverter's AC output or its hardwire output.

*CAUTION:* The inverter contains a circuit breaker and capacitor that may produce a spark. Do not mount in a confined battery or gas compartment.

*CAUTION:* Working in the vicinity of lead-acid

batteries is dangerous. Batteries generate explosive gases during operation. There is a risk of acid exposure. There is also a risk of high current discharge from shorting the battery that can cause fire and explosion.

*CAUTION:* Be sure the inverter's circuit breaker or fuse are turned off during installation.

### 2. DESCRIPTION

**2.01** The inverter converts 12 VDC to 120 VAC, 60 HZ, having a pure sine wave form.

**2.02** The inverter has a controlled frequency at 60 HZ  $\pm$  0.05%.

**2.03** The inverter has internal protection against output short circuit, output overload and high temperature conditions. Also, there is a thermally controlled cooling fan.

**2.04** The inverter is designed to operate any 120 VAC, 60 HZ single phase appliance, equipment or tool within its power ratings.

<b>Inverter Rating</b>				
Inverter	Input	Output		
Model	(VDC)	(ADC)	(VAC)	(Watts)
12/800N	12.6	Up to 80	120	800
12/1200N	12.6	Up to 120	120	1200

### 3. INSTALLATION

**3.01** The following instructions should be thoroughly read and understood before installation.

**3.02 CAUTION:** Inverters produce hazardous voltages, to avoid risk of harm or fire the unit must be properly installed.

*CAUTION:* Damage to the inverter will occur if correct polarity is not observed when installing the DC input cables.

*CAUTION:* Damage to the inverter will occur if an external AC power source is applied to the inverter's AC outlet or its hardwire output.

*CAUTION:* Be sure the inverter's circuit breaker or fuse are turned "OFF" during installation.

**NOTE:** All wiring must follow the National Electric Code, Provincial or other codes in effect at the time of installation, regardless of suggestions in this manual. All wires should be copper conductors.

### 3.03 Mounting

**3.03.1** Locate a suitable, secure vertical or horizontal mounting surface as close to the battery as possible without being in the same air tight compartment. The maximum recommended distance between the mounting location and the battery is 20 feet.

**CAUTION:** Mount the inverter on a vertical surface with the front control panel pointing down.

**3.03.2** The location should provide adequate ventilation and clearance to prevent unit overheating during operation. At least 1/2 inch of clearance is required on all sides.

**3.03.3** Secure the unit with 1/4 inch screws or bolts in the mounting slots on the flanges of the chassis.

### 3.04 Chassis Bonding Lug - FIG. 1

**3.04.1** Connect a #8 gauge or greater copper wire between the bonding lug on the inverter and the earth grounding system or the vehicle chassis.

### 3.05 Battery Wiring - FIG. 1

**3.05.1** *CAUTION:* Assure that hydrogen gas does not accumulate near the battery by keeping the area well ventilated. A spark may result when connecting the final battery wiring due to an initial charging of the internal input capacitor.

**3.05.2** Use stranded copper wire between the battery and inverter as indicated. A line fuse must be installed between the battery and the inverter. Codes require that the fuse be within 18 inches of the battery.

### DC Input Wire Lengths (maximum) and Fusing Guide

Model	Distance(feet)			
	1-10	11-15	16-20	
12/800N	6 ga	4 ga	2 ga	
12/1200N	4 ga	2 ga	1 ga	
AWG:	6	4	2	1
Fuse:	150A	200A	250A	300A

**3.05.3** Using smaller input cable or longer length will greatly degrade the inverter peak performance.

**IMPORTANT NOTE FOR VEHICLE INSTALLATION:** Do not use the vehicle chassis as the negative return in place of a return cable. Use the same size cable as the positive connection and run directly to the battery.

**3.05.4** Install the wires at the battery, inverter and then fuse holder. Make sure that clean, tight connections are made. Use care not to touch the positive and negative wires together, a violent spark will result and could cause exploding batteries and fire.

**3.05.5** The battery input terminals are located in the wiring compartment. A mounting spark may result when connecting the battery wire, due to an initial charging of the of the internal input capacitor.

**3.05.6** *CAUTION:* Connecting the inverter incorrectly to the battery will cause damage that is not covered under warranty.

### 3.06 Remote Switch for Inverter Operation - Fig. 1

**3.06.1** All material used for the remote switch should be U.L. listed and installed per low voltage, Class 2, wiring code.

**3.06.2** A remote switch may be connected to the violet wire marked "Remote Switch Hookup" in the wiring compartment. You should first remove this violet wire from the battery positive input terminal; then connect the violet

wire to the load side of the remote switch. Fused, positive battery voltage is connected to the line side of the switch. The cable clamp strain relief should be used to secure the field wires.

**3.06.3** The switch should be mounted at a convenient location in a listed outlet box with approved strain relief.

**3.06.4 NOTE:** A remote switch, if installed, will operate **only if** the local ON/OFF switch on the face of the inverter is turned "On". You may use several switches or relays in parallel in lieu of one remote switch. If the remote switch is not used, the inverter can be turned "Off" or "On" with the switch on the inverter.

### **3.07 120 VAC Output**

**3.07.1 CAUTION:** Do not connect another source of AC power directly to the output of the inverter. This will result in damage to the inverter that is not covered under warranty!

**3.07.2** The 120 VAC output of the inverter is provided at the GFCI receptacle outlet on the inverter.

**3.07.3** The output is also presented behind the wiring compartment panel for direct hardwire wire leads. The black wire is hot, the white wire is neutral and the green wire is ground. The cable clamp strain relief should be used to secure the field wires.

**3.07.4** The hardwire A.C. output is not ground fault circuit interrupt (GFCI) protected. GFCI outlets should be installed at all appropriate locations per NEC 551 . The GFCI outlet should be Hubbell, Model GFR5352XX (20A) or GFR5252XX (15A).

**3.07.5** The remote AC outlets should be mounted at a convenient location in a listed outlet box with approved strain relief.

## **4. START-UP/OPERATION**

**4.01** To operate the inverter, turn the switch to "ON". Assure that the output breakers are reset. If a remote switch is used, the inverter is

turned "On" or "Off" by the remote switch.

## **5. TROUBLESHOOTING**

**5.01** Dimensions offers free phone consultation concerning installation or troubleshooting. Call the Customer Service Department at 1-800-553-6418 or 651-653-7000; fax: 651-653-7600 e-mail: [inverterinfo@Airpax.net](mailto:inverterinfo@Airpax.net)

**5.02** If the inverter fails to operate, use the following troubleshooting procedure.

**5.02.1** Connect a 100 watt light bulb to the inverter output.

**5.02.2** Make sure that the inverter is turned "On" along with the remote switch, if used, and that the circuit breakers are reset.

**5.02.3** Check the connection to the remote switch, if used. +12 VDC **must** be present at the violet wire for the unit to operate. If not, check any fuses in the +12VDC remote switch circuit.

**5.02.4** Observe the fault indicating lights on the front of the inverter.

a) The Low battery light indicates a low battery condition. Switch the inverter "Off" for 5 seconds, then "On" again. The light coming on again indicates a fault in the battery wiring, battery capacity and voltage or the line fuse.

b) The Overload light indicates an output wiring short circuit or a load that is too large for the power rating of the inverter. Switch the inverter "Off", remove the short circuit or excessive load from the output, then switch the inverter back "On".

c) The High temperature light indicates the inverter has overheated. The unit will automatically turn back on when it has cooled to 40 degrees C (104 degrees F). Verify the inverter is not in a closed compartment and that the fan is not blocked.

**5.03** Call Airpax Dimensions, Inc. for technical assistance and/or a return authorization number if the above steps are completed and the inverter still will not operate satisfactorily.

Figure #1

**WARNING: CONNECTING THE BATTERY WITH THE WRONG POLARITY TO THE INVERTER WILL CAUSE DAMAGE THAT IS NOT COVERED UNDER THE WARRANTY.**

# FRONT VIEW

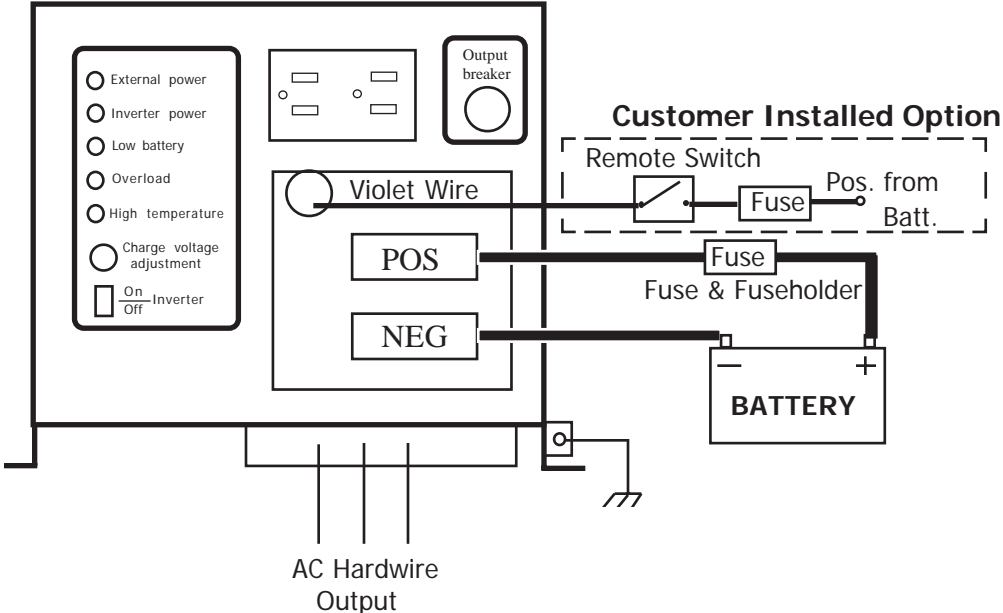

## Limited Warranty Terms & Conditions

### SHIPPING TERMS

F.O.B. St. Paul Minnesota. Freight prepaid and billed, subject to prior credit approval.

### MINIMUM ORDER

\$50.00 Net Price

### LOSS OR DAMAGE

Loss or damage in transit are the responsibility of the carrier. Any claim should be filed with the delivering transport company. Invoice, Bill of Lading and Delivery receipt with damage noted therein must accompany any claims for freight damage. Claims for shortage and lost shipments must be made in writing to Airpax Dimensions, St. Paul, MN within 10 days of date of shipment. Claims not reported within this time frame will not be honored.

### PRICES

Prices are subject to change without notice. All orders are subject to acceptance at the factory. We reserve the right to invoice prices in effect at time of shipment.

### TERMS

Net 30 days with approved credit, credit card or C.O.D.

### RETURN GOODS POLICY

- No returned materials will be accepted without an accompanying Returned Materials Authorization Number (RMA) from the factory.
- Credit will be issued for returned goods to the original purchaser within 60 days of purchase, provided the inverter is returned to Dimensions unused and not mounted. The amount of credit will be issued at Dimensions discretion based on the condition of the product.
- Customer must be in good standing with Dimensions.
- Inverters that are discontinued, high-voltage (over 24vdc), special-order or used are excluded and will not be eligible for credit. Non-inverter items such as cable assemblies, fuses and fuse holders, will not be eligible for credit
- Support components supplied by Dimensions vendors will be covered under that manufacturer's credit return policy.
- Customer pays return freight.

**PLEASE SHIP AUTHORIZED RETURNS TO:** Airpax Dimensions, Inc. / 4467 White Bear Parkway / St. Paul, MN 55110  
**Return Freight Prepaid**

### LIMITED WARRANTY

Airpax Dimensions, Inc. extends the following warranty to the original purchaser of those goods subject to the qualifications indicated.

Dimensions warrants to the original purchaser for use that the goods or any component thereof manufactured by Dimensions will be free from defects in workmanship from the date of purchase for the period listed on the product label, provided such goods are installed, maintained and used in accordance with Dimensions and the original manufacturer's written instructions.

Components not manufactured by Dimensions, but used within the assembly provided by Dimensions, are subject to the warranty period as specified by the individual manufacturer of said component, provided such goods are installed, maintained and used in accordance with Dimensions and the manufacturer's written instructions.

Dimensions sole liability and the Purchaser's sole remedy for a failure of goods under this limited warranty and for any and all claims arising out of the purchase and use of the goods, shall be limited to the repair or replacement of the goods that do not conform to this warranty.

To obtain repair or replacement service under the limited warranty, the purchaser must contact the factory for a Return Material Authorization (RMA). Once obtained, send the Return Material Authorization Number along with the defective part or goods to: Airpax Dimensions, Inc., 4467 White Bear Parkway, St. Paul, MN 55110, freight prepaid.

THERE ARE NO EXPRESS WARRANTIES COVERING THESE GOODS OTHER THAN AS SET FORTH ABOVE. THE IMPLIED WARRANTIES OF MERCHANTABILITY AND FITNESS FOR A PARTICULAR PURPOSE ARE LIMITED IN DURATION TO ONE YEAR FROM DATE OF PURCHASE.

DIMENSIONS ASSUMES NO LIABILITY IN CONNECTION WITH THE INSTALLATION OR USE OF THE PRODUCT, EXCEPT AS STATED IN THIS LIMITED WARRANTY. DIMENSIONS WILL IN NO EVENT BE LIABLE FOR INCIDENTAL OR CONSEQUENTIAL DAMAGES.

### WARNING: LIMITATIONS ON USE

Dimensions products are not intended for use in connection with Life Support Systems and for Avionic use. Dimensions makes no warranty or representation in connection with their products for such uses.