

**SNAPNRACK RL UNIVERSAL FRONT ROW WITH SKIRT DETAILS**

**AVAILABLE IN TWO LENGTHS:**

- LANDSCAPE: SIZED TO LONG END OF 60-CELL MODULE
- DOUBLE PORTRAIT: SIZED TO TWO SHORT ENDS OF A MODULE PLUS A 3/4" MODULE SPACING
- NOTE: CUTTING SKIRT DOWN TO DESIRED LENGTH IS PERMITTED

RL UNIVERSAL SKIRTS AND SKIRT SPACERS ARE REQUIRED ON THE FRONT ROW OF AN ARRAY TO:

1. SET THE CLAMP HEIGHT OF THE FIRST ROW OF RL UNIVERSAL MOUNTS / LINKS TO THAT OF THE INSTALLED MODULES FOR A PROPER ROCK-IN INSTALLATION
2. PROVIDE STRUCTURAL INTEGRITY TO THE FIRST ROW OF MOUNTS AND LINKS

HEIGHT SPECIFIC SKIRT SPACERS MUST BE MATCHED TO THE FRAME HEIGHT OF THE MODULE INSTALLED. REFER TO SPACER COLORS AND SIZE MARKINGS, AS SHOWN

REFER TO SNAPNRACK INSTALLATION MANUAL FOR HARDWARE TORQUE SPECIFICATIONS

REVISION:			
1	5/1/2019	NEW DETAIL	MJA

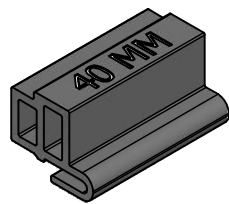

**SKIRT SPACER, 40 MM (SILVER)**

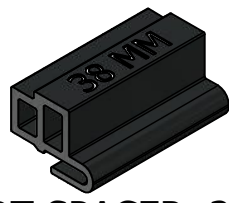

**SKIRT SPACER, 38 MM (BLACK)**

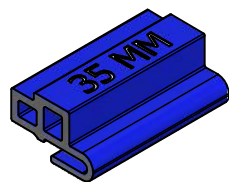

**SKIRT SPACER, 35 MM (BLUE)**

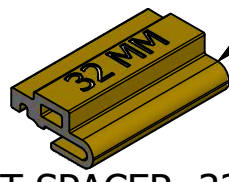

**SKIRT SPACER, 32 MM (GOLD)**

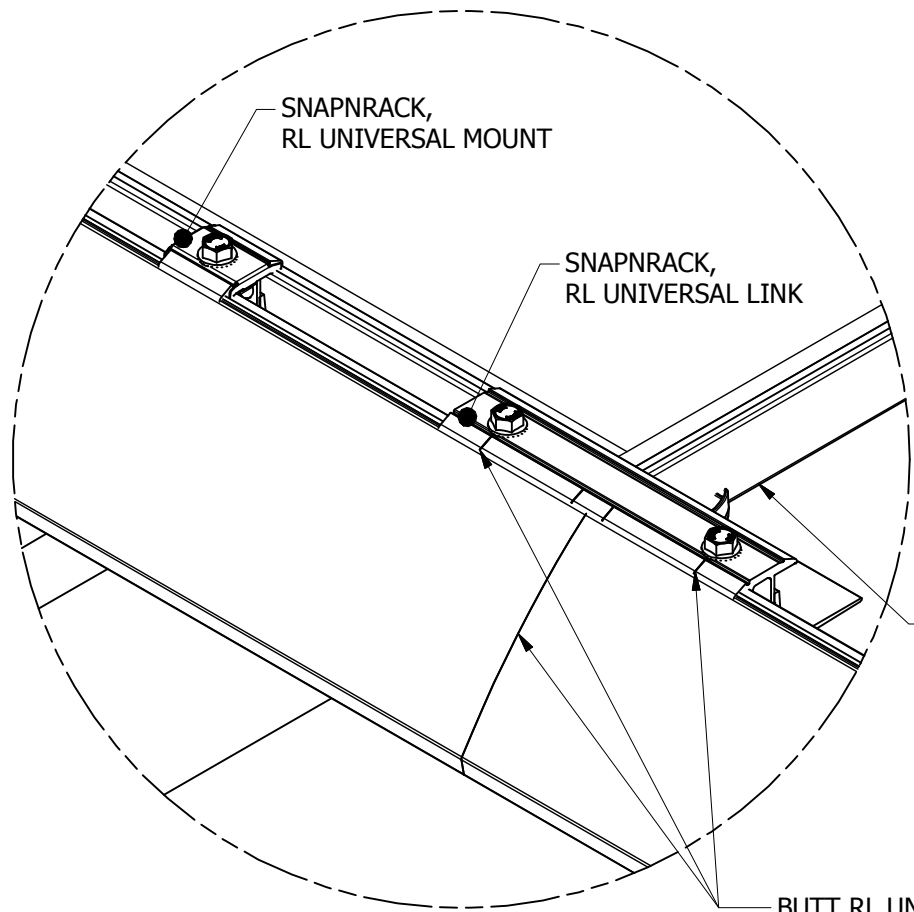

**DETAIL A**

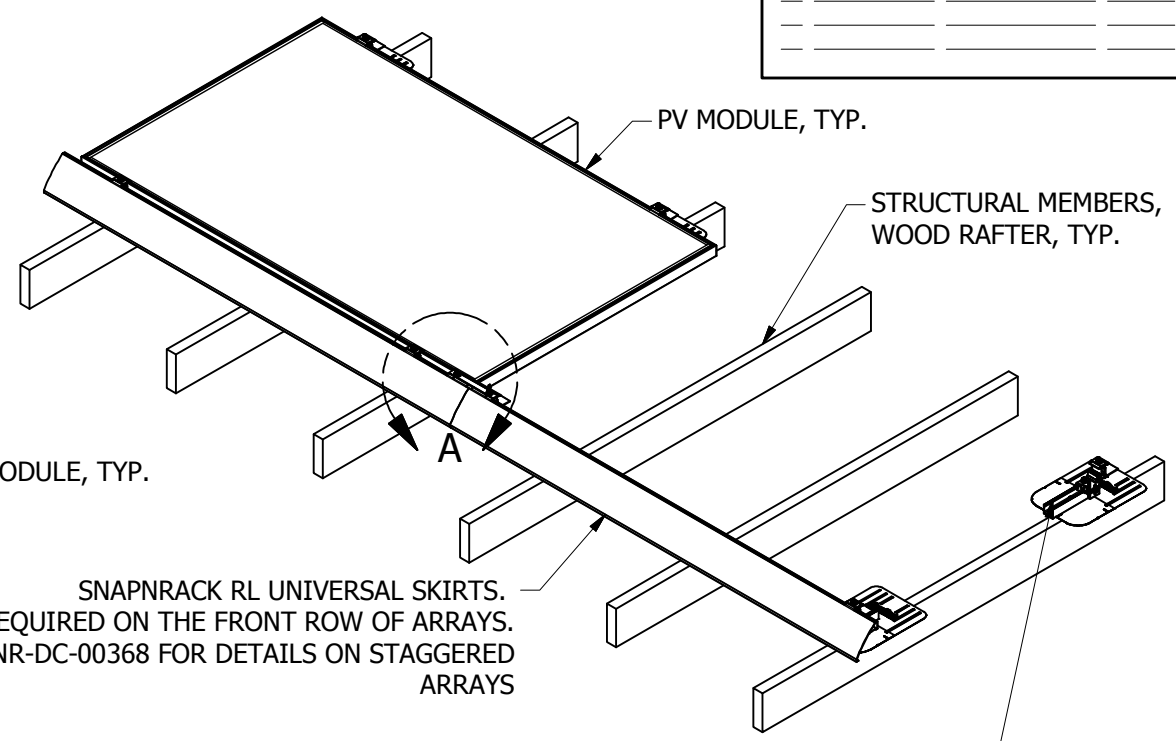

BUTT RL UNIVERSAL SKIRTS TOGETHER AND SPLICE WITH THE RL UNIVERSAL LINK. LOCATE SKIRT JOINT WITHIN OUTER MARKS ON THE LINK, AS SHOWN

(X1) SKIRT SPACER PER RL UNIVERSAL MOUNT

COLOR AND SIZE STAMP ARE MATCHED TO MODULE FRAME HEIGHT

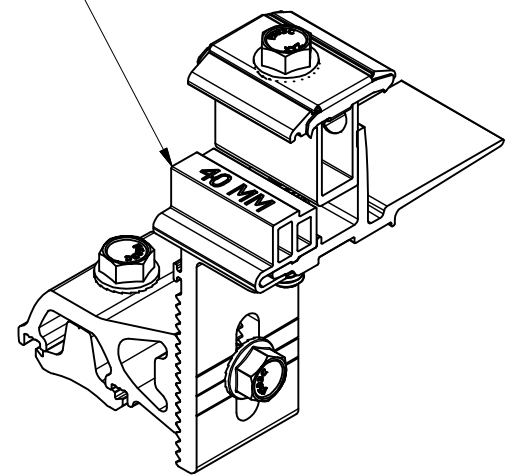

**SNAPNRACK, RL UNIVERSAL MOUNT WITH SKIRT SPACER**

(X3) SKIRT SPACERS PER RL UNIVERSAL LINK

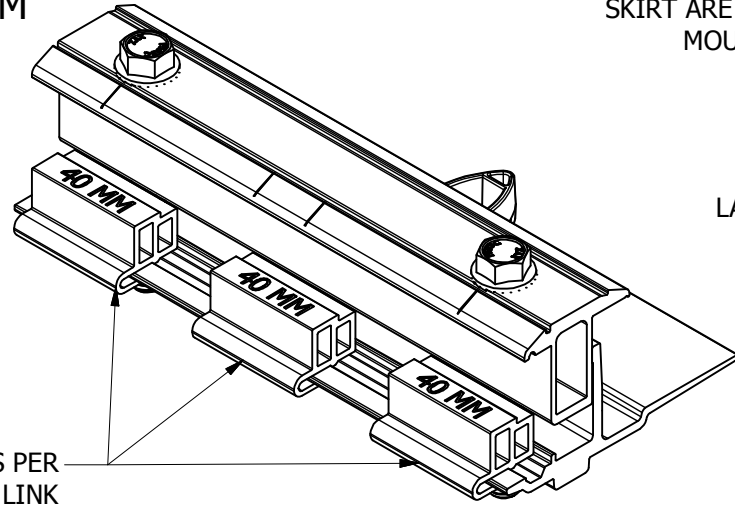

**SNAPNRACK, RL UNIVERSAL LINK WITH SKIRT SPACERS**

ENSURE CATCHES ON TOP AND BOTTOM OF SKIRT ARE FULLY SEATED INTO FEATURES ON MOUNT AND SKIRT SPACER, AS SHOWN

RL UNIVERSAL SKIRT (PORTRAIT OR DOUBLE LANDSCAPE LENGTHS, TYP.)

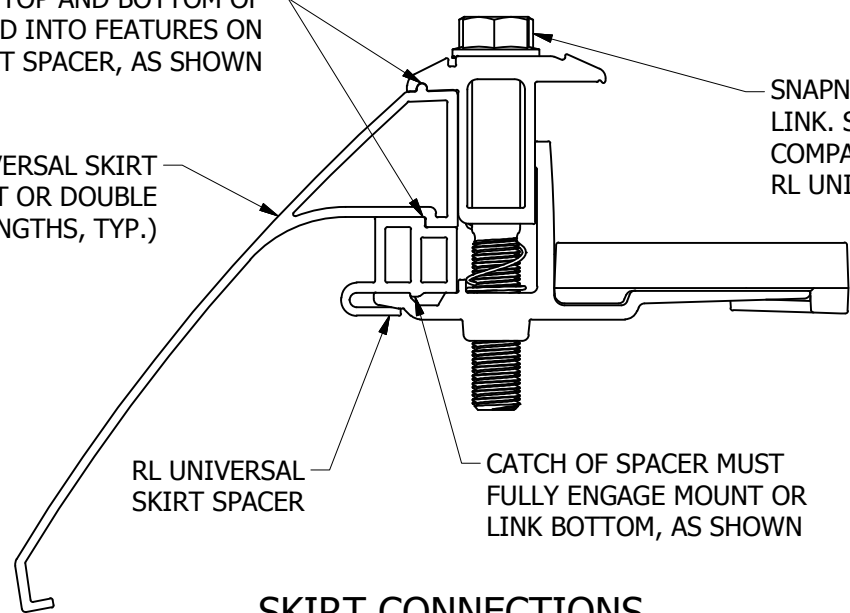

**SKIRT CONNECTIONS**