

BRAVO 1050

Inverter/Battery Charger



Table of Contents

Introduction.....	2
General Description.....	2
Specifications	3
Installation: Hardwire Units	4
Operation: Hardwire Units	5-6
Installation: GFCI Receptacle Units	7
Operation: GFCI Receptacle Units	8-9
Troubleshooting and Test Record.....	10-11
Warranty.....	12



INTRODUCTION

Thank you for purchasing a Vanner Bravo Power Inverter/Battery Charger. We are confident that you will be very pleased with its performance. Vanner Inverter/Battery Chargers are designed and manufactured by skilled professionals using the highest standards in workmanship. With minimum maintenance and care, you can be assured of many years of trouble-free service.

GENERAL DESCRIPTION

There are four basic models available. The hardwired units (models with H suffix on the P/N) have 3 wires (black for hot, white for neutral, green for GND) used to connect the AC input of the inverter/charger to the AC input power with wire nuts, and 3 similar wires with wire nuts to connect the AC output of the inverter/charger to its AC load center. Models with G suffix on the P/N have an AC line cord installed at the factory for connecting to AC input power and a receptacle with a GFCI (Ground Fault Circuit Interrupter) for plugging AC loads directly into the inverter. This model requires no wiring by the customer on the AC side of the inverter.

Bravo is a high performance combination inverter and battery charger. The inverter is connected to a battery through proper fusing and can also be connected to AC input power. Loads connected to Bravo will be powered from the battery when AC input power is not available. When AC input power is restored (after a brief delay to ensure that full power is available), the load is switched back to AC input power and the battery charger activates automatically to recharge the battery.

Inverter:

The Bravo QBC10 converts the power of a battery to 1050 watts of 120 VAC modified sine wave power to operate lights, tools and appliances. Bravo is simply connected to the positive and negative posts of a battery system with appropriate fusing and, when turned on, produces 120 VAC power. The inverter also has an energy saving feature called Load Demand. While in Load Demand mode, the inverter output is pulsed. This significantly reduces the current draw from the battery until a demand is made on its output. Continuous output of 120 VAC resumes when a load greater than 5 watts is applied.

Battery Charger:

The Bravo battery charger is superior to standard chargers. Bravo incorporates a unique three stage charger design which allows it to correctly charge batteries automatically. While in the BULK stage, Bravo charges continuously at full output of 55 (27.5) amps* until the battery cells have charged to 14.2/14.1 (28.4/28.2) VDC (flooded/gel). Then the charger goes into ABSORPTION stage, maintaining 14.2/14.1 (28.4/ 28.2) VDC until the battery is fully charged. Bravo then automatically switches to the FLOAT stage. The FLOAT stage maintains the battery at a correct voltage of 13.2/13.6 (26.4/27.2) VDC. The three stage design keeps batteries in top condition and reduces battery failure.

*A front panel mounted Battery Charger High/Low dipswitch is provided to limit the output from 55 (27.5) amps to 27.5 (13.7) amps



SPECIFICATIONS

INVERTER Model #	QBC10-12	QBC10-24
Output at 120 VAC-Continuous	1050 Watts	
Surge Capacity at 120 VAC (3 secs)	2100 Watts	
Input Voltage, VDC (Deep Cycle Battery Recommended)	12 VDC, Nominal, 10.5 VDC min., 16.0 VDC Max.	24 VDC, Nominal, 21.0 VDC min., 32.0 VDC Max.
Output Voltage	120 VAC \pm 5% ...	
No Load Current Draw (Battery)	75 ma (Load Demand ON)	55 ma (Load Demand ON)
No Load Current Draw (Battery)	20 ma (Power OFF)	25 ma (Power OFF)
Frequency	60Hz \pm 0.1%	
Output Waveform	Modified Sine Wave	
BATTERY CHARGER (if equipped)		
Charging Capacity, AMPS	55 or 27.5 AMPS	1 27.5 or 13.7 AMPS
Input voltage, VAC	120 VAC \pm 10%	
Input Current, IAC	8.0	
Bulk Voltage, VDC	14.2 (flooded) 14.1 (Gel)	28.4 (flooded) 28.2 (Gel)
Float Voltage, VDC	13.2 (flooded) 13.6 (Gel)	26.4 (flooded) 27.2 (Gel)
Bypass		
Output Current, hardwired (H suffix)	30 amps	
Output Current, GFCI (G suffix)	12 amps	
Ambient Temperature	-40 to +105°F, -40 to +40°C	
Cooling Air	Fan-cooled, 30 cfm	
Chassis	Aluminum	
Dimensions GFCI	11.57" W x 5.94" H x 11.04" D	
Dimensions Hardwire	11.57" W x 5.94" H x 13.04" D	
Weight	22 LBS	



INSTALLATION: HARDWIRED UNITS

CAUTION! Battery input cables must be connected to the battery with proper polarity as instructed or damage to the inverter may occur.

1. The unit should be OFF before installation begins. Make sure the ON-OFF/RESET Inverter Switch is in the OFF-RESET position (button NOT pushed in).
2. Select a location for the unit that is: a) close to the battery—within 6 ft. using #2 gauge wire, b) protected from the weather, and c) well ventilated.
3. Route the negative and positive DC input cables from the inverter/charger to the battery. If required, protect cables where they come into contact with hard or sharp edges.
4. Install an inline fuse (Bussman ANN 125 for 12 volt applications or ANN 80 for 24 volt applications) in the positive (RED) DC input cable between the battery and inverter (within 18" of the battery).
5. Connect the negative (BLACK) DC input cable to the battery negative (-) terminal. Connect the positive (RED) DC input cable to the battery positive (+) terminal.
6. Select the proper battery type (GEL or flooded lead acid), load demand option, and charge rate using recessed switch on front panel.
7. Connect the AC input of field wiring compartment to AC source using properly sized wire and wire nuts (10AWG recommended).
8. Wire AC output to appropriate branch circuits. All branch circuits of a recreational vehicle which are powered by this inverter must use one of the following GFCI: Hubbell GF5252GYA, GFRST15W**, Pass and Seymour 1591-GRY, Pass and Seymour 2091-SGRY, GE THQL-1115GF or Leviton 6490-I.
9. Verify all connections are tight and secure for maximum performance. Installation is now complete.

**Note: If GFCI trips and the inverter is in load demand mode the GFCI may not reset until you toggle inverter off and back on and then you will have 5 seconds to reset GFCI before unit goes back into load demand again or you can disable load demand via dipswitch, if available.

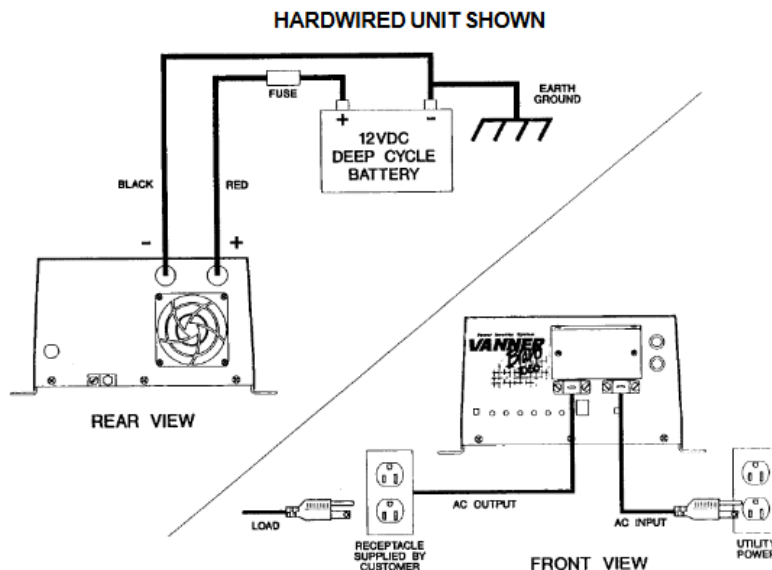



OPERATION: HARDWIRED UNITS

1. With installation complete, apply AC input power to the unit. The charger will activate automatically, and either the CHARGE or READY lamp will light depending on battery status. The unit is now charging the battery.
2. Apply an AC load with utility power present and the AC load is run directly off utility power. The ON-OFF/ RESET Inverter Switch has no effect on the unit's AC output when utility power is present. The ON-OFF/RESET Inverter Switch only controls the inverter section of the unit.
3. Push in the ON-OFF RESET Inverter Switch to the ON position. If utility power is present the ON lamp will FLASH. The FLASH indicates the inverter is standing by.
4. If utility power is removed or lost and the ON-OFF RESET Inverter Switch is in the ON position, the unit will automatically switch to inverter and operate the AC load using battery power. The READY and CHARGE lamps will be off and the ON lamp will light fully.
5. If utility power is restored, the inverter will, after a 5 second delay, switch to battery charging and run the AC load direct. The ON lamp will FLASH indicating the inverter is on standby and either the CHARGE or READY lamp will light depending on battery status.
6. With ON-OFF/RESET Inverter Switch in the ON position, a double flash of the ON lamp indicates that load demand is turned on and the load is less than 5 watts.

DIMENSIONS (HARDWIRED)

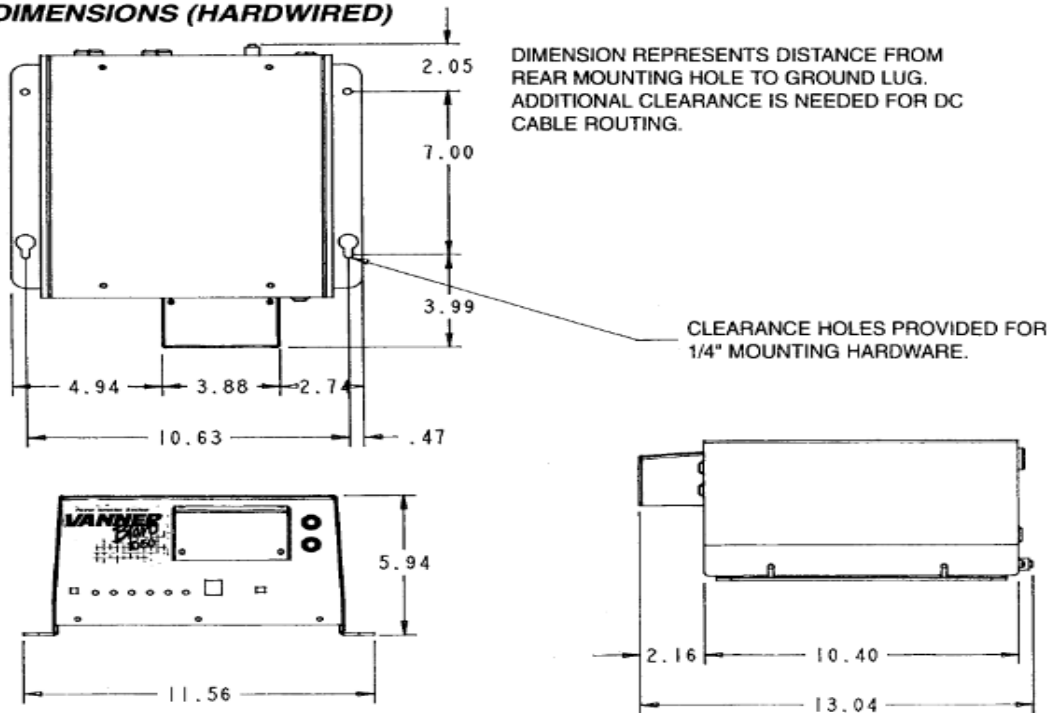

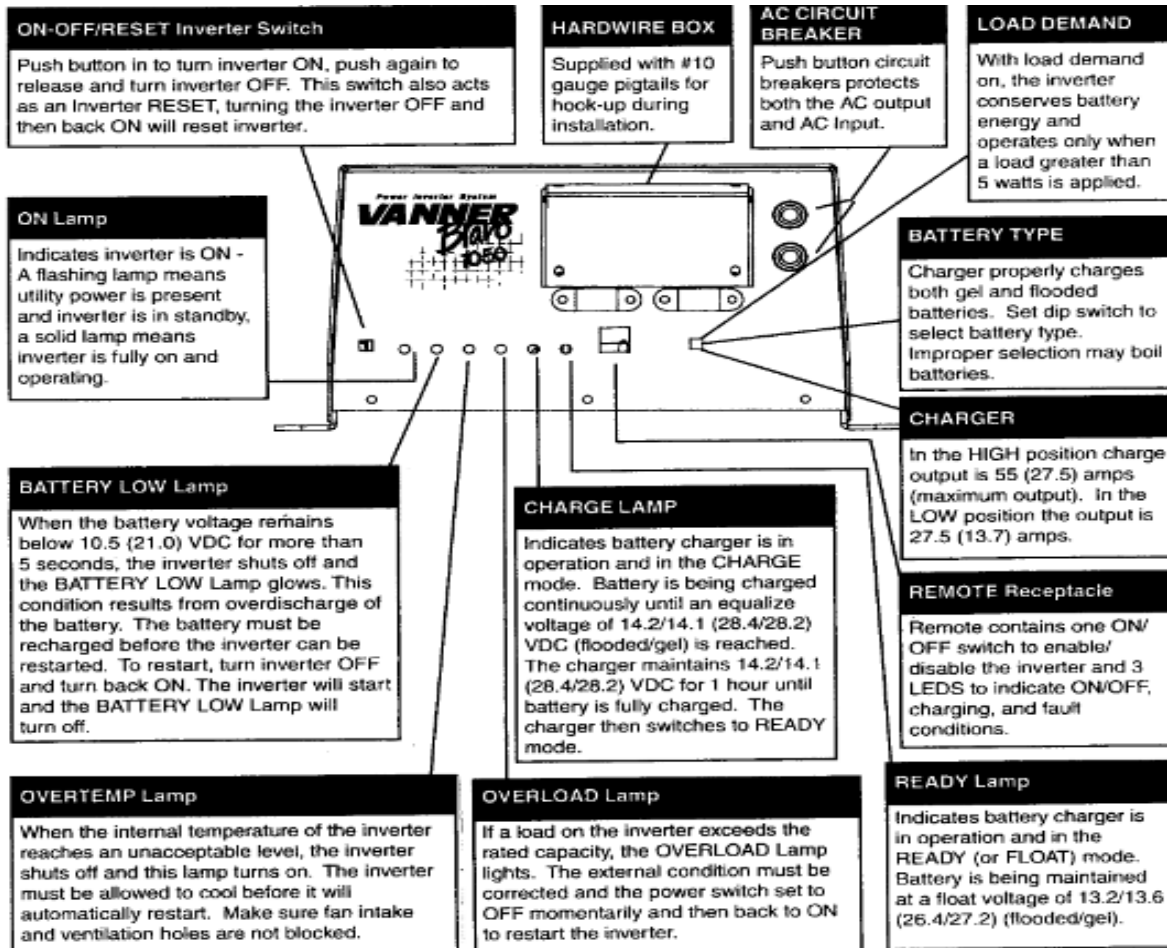

BACK PANEL

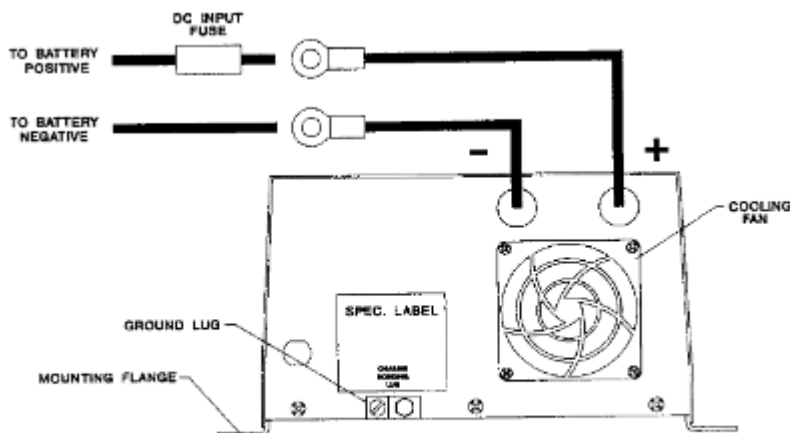

REAR VIEW

INSTALLATION: GFCI RECEPTACLE UNITS

CAUTION! Battery input cables must be connected to the battery with proper polarity as instructed or damage to the inverter may occur.

1. The unit should be OFF before installation begins. Make sure the ON-OFF/RESET Inverter Switch is in the OFF-RESET position (button NOT pushed in).
2. Select a location for the unit that is: a) close to the battery—within 6 ft. using #2 gauge wire, b) protected from the weather, and c) well ventilated.
3. Route the negative and positive DC input cables from the inverter/charger to the battery. If required, protect cables where they come into contact with hard or sharp edges.
4. Install an inline fuse (Bussman ANN 125 for 12 volt applications or ANN 80 for 24 volt applications) in the positive (RED) DC input cable between the battery and inverter (within 18" of the battery).
5. Connect the negative (BLACK) DC input cable to the battery negative (-) terminal. Connect the positive (RED) DC input cable to the battery positive (+) terminal.
6. Select the proper battery type (GEL or flooded lead acid), load demand option, and charge rate using recessed switch on front panel.
7. Verify all connections are tight and secure for maximum performance. Installation is now complete.

GFCI UNIT SHOWN

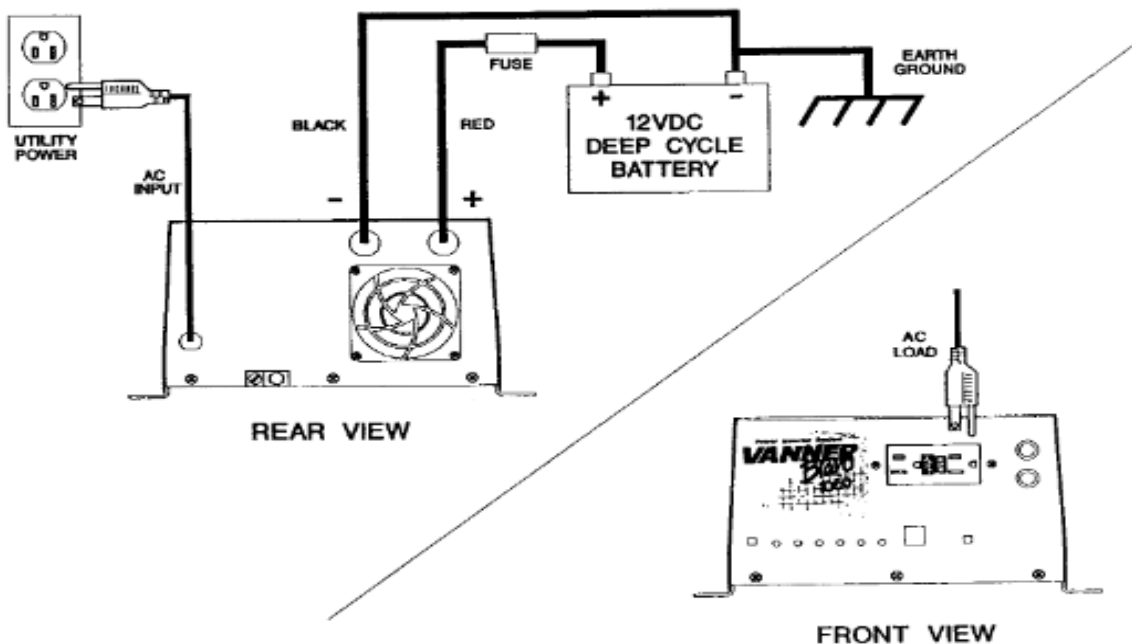



OPERATION: GFCI RECEPTACLE UNITS

1. With installation complete, plug the AC Input Power Cord into a utility power outlet. The charger will activate automatically, and either the CHARGE or READY lamp will light depending on battery status. The unit is now charging the battery.
2. Apply an AC load with utility power present and the AC load is run directly off utility power. The ON-OFF/RESET Inverter Switch has no effect on the unit's AC output when utility power is present. The ON-OFF/RESET Inverter Switch only controls the inverter section of the unit.
3. Push in the ON-OFF RESET Inverter Switch to the ON position. If utility power is present the ON lamp will FLASH. The FLASH indicates the inverter is standing by.
4. If utility power is removed or lost and the ON-OFF RESET Inverter Switch is in the ON position, the unit will automatically switch to inverter and operate the AC load using battery power. The READY and CHARGE lamps will be off and the ON lamp will light fully.
5. If utility power is restored, the inverter will, after a 5 second delay, switch to battery charging and run the AC load direct. The ON lamp will FLASH indicating the inverter is on standby and either the CHARGE or READY lamp will light depending on battery status.
6. With ON-OFF/RESET Inverter Switch in the ON position, a double flash of the ON lamp indicates that load demand is turned on and the load is less than 5 watts.

DIMENSIONS (GFCI)

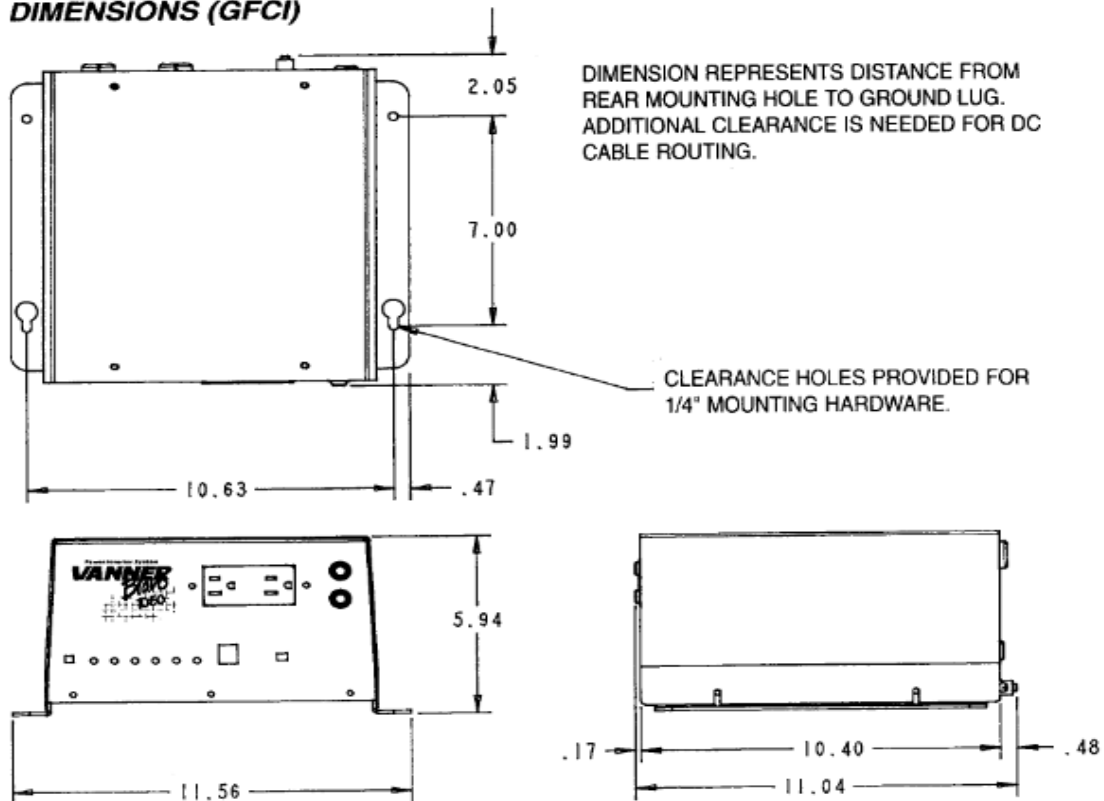



Owner's Manual

FRONT PANEL

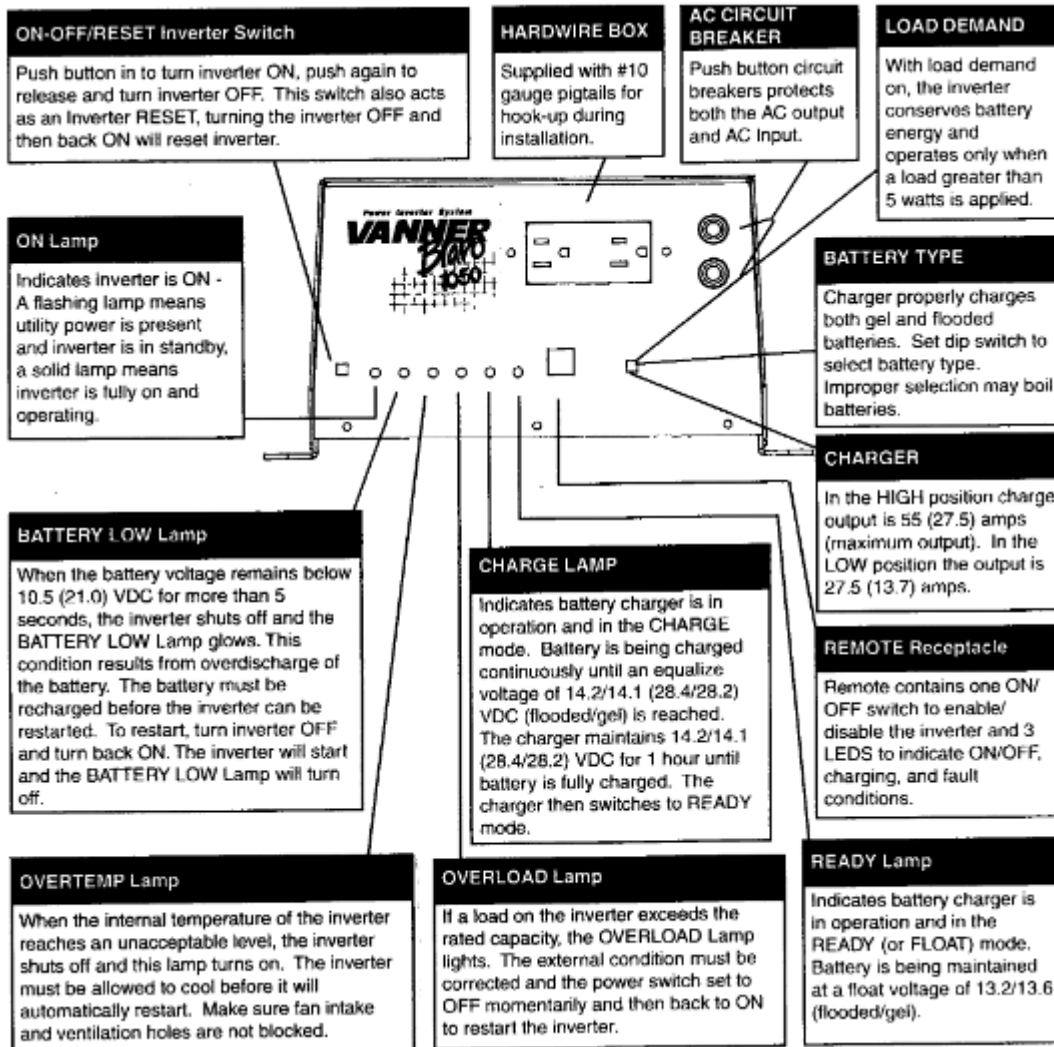

BACK PANEL

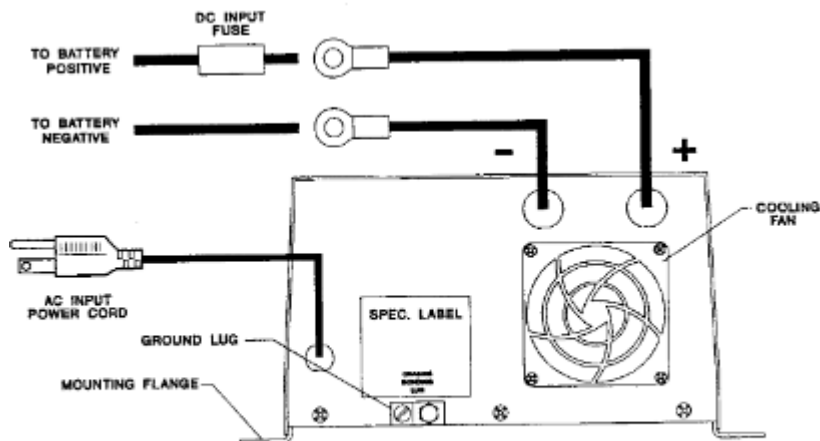

REAR VIEW



TROUBLESHOOTING

SYMPTOM	SOLUTION
ON lamp does not light fully after pushing in the ON- OFF RESET Inverter Switch.	<ul style="list-style-type: none"> • If utility power is present, lamp will only FLASH • If utility power off, check battery connections • If utility power off, check DC fuses
ON lamp lights fully but AC load will not run.	<ul style="list-style-type: none"> • Check and reset circuit breaker • Check and reset GFCI receptacle** • Verify AC load and cord are in good condition
BATTERY LOW lamp lights when AC load is applied.	<ul style="list-style-type: none"> • Check battery connections • If battery voltage is less than 21.0 VDC, recharge battery • Add <i>an</i> additional battery
OVERTEMP lamp lights after unit has been running for a period of time.	<ul style="list-style-type: none"> • Remove objects that obstruct air flow to the cooling fan or from ventilation holes. • Verify AC load is within unit's rated capacity
OVERLOAD lamp lights when AC load is applied.	<ul style="list-style-type: none"> • Verify AC load is within unit's rated capacity • Try smaller AC load
Battery charger will not turn on. No CHARGE or READY lamp.	<ul style="list-style-type: none"> • Verify AC input cord is plugged into utility power and power is present. • Check and reset circuit breaker • Wait 5 seconds after utility power is restored
DC fuse blows when connecting DC input cables.	<ul style="list-style-type: none"> • Check for reverse polarity

**Note: If GFCI trips and the inverter is in load demand mode the GFCI may not reset until you toggle inverter off and back on and then you will have 5 seconds to reset GFCI before unit goes back into load demand again or you can disable load demand via dipswitch, if available.

If further assistance is required, please contact your local Vanner authorized service center or call 1-800-AC POWER.



OPTIONS

Remote panel provides ON/OFF control and status monitoring. Remote has 3 LEDs to indicate present status. The red LED lights when a fault occurs, the yellow when charging is in progress, and the green when the inverter is on or in load demand.

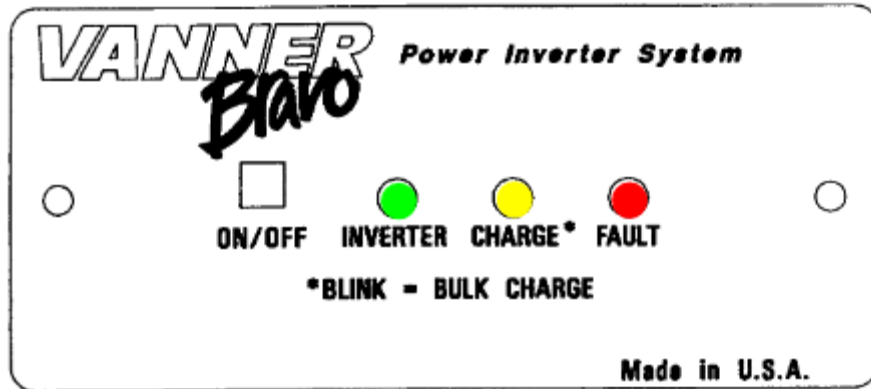

GFCI TEST RECORD

For maximum protection against electrical shock hazard, operate test switch on Ground Fault Circuit Interrupter at least once a month. We recommend that this page be copied and the copy placed in your maintenance notebook.

ENTER YEAR	JAN	FEB	MAR	APR	MAY	JUNE	JULY	AUG	SEPT	OCT	NOV	DEC
20_												



LIMITED WARRANTY

NORTH AMERICAN LIMITED WARRANTY

Vanner Inc., referred to herein as Vanner, warrants that this product is free from defects in materials and workmanship for a period of two (2) years from date of installation or two and one half (2 1/2) years from date of manufacture, whichever is less if and only if the following requirements are complied with:

1. The product is installed and checked out properly according to all guidelines, instructions, and checkout procedures set forth in the product Installation and Operating Manual.
2. The installer records all checkout data required and completes, signs, and returns the warranty registration card to Vanner within ten (10) days after installation.
3. The product was purchased after January 1, 2000.

Vanner does not warrant its products against any and all defects when: defect is a result of material or workmanship not provided by Vanner; normal wear and tear, or defects caused by misuse or use in contrary to instructions supplied, neglect, accident, reversed polarity, unauthorized repairs and/or replacements.

All warranties of merchantability and fitness for a particular purpose: written or oral, expressed or implied, shall extend only for a period of two (2) years from date of installation or two and one half (2 1/2) years from date of manufacture, whichever is first. There are no other warranties that extend beyond those described on the face of this warranty. Some states do not allow limitation on how long an implied warranty lasts, so the above limitations may not apply to you.

Vanner does not undertake responsibility to any purchaser of its product for any undertaking, representation, or warranty made by any dealers or distributors selling its products beyond those herein expressed unless expressed in writing by an officer of Vanner.

Vanner does not assume responsibility for incidental or consequential damages, including, but not limited to, responsibility for loss of use of this product, removal or replacement labor, loss of time, inconvenience, expense for telephone calls, shipping expense, loss or damage to property, or loss of revenue. Some states do not allow the exclusion or limitation of incidental or consequential damages, so these limitations may not apply to you.

Vanner reserves the right to repair, replace, or allow credit for any material returned under this warranty. Any damage caused by the customer will be charged or deducted from the allowance.

All warranty work will be performed at Vanner's factory, or authorized repair facility utilizing a valid Warranty Authorization Number (WAN) prior to repair. Products shall be delivered to Vanner's facility, freight prepaid and fully insured. Products repaired under warranty, or replacement parts or products will be returned to North American location prepaid via same transportation means and level of service as received, unless directed otherwise. Prepaid freight policy does not apply to locations outside North America.

Vanner Inc.

4282 Reynolds Drive
Hilliard, Ohio 43026
Tel (614) 771-2718
Fax (614) 771-4904
www.vanner.com

Specifications Subject to Change
Copyright 1996, Vanner Inc.
Printed in the USA
OM/A96199 REV B 08/2016