

NOTES: UNLESS OTHERWISE SPECIFIED

1. SEE DRAWING NO. CB-00292 AND PROCEDURE P-1000 FOR ASSEMBLY AND TEST INSTRUCTION. PROCEDURES AND ASSEMBLY DRAWINGS ARE FOR INTERNAL USE ONLY.
2. ALL TESTING IS PERFORMED IAW BATTERY COUNCIL INTERNATIONAL STANDARDS.
3. DIMENSIONS ARE INCH [MILLIMETERS].
4. ABBREVIATION USED IN TITLE IS: SEALED LEAD ACID (SLA).

REVISIONS			
REV	DESCRIPTION	DATE	APPROVED

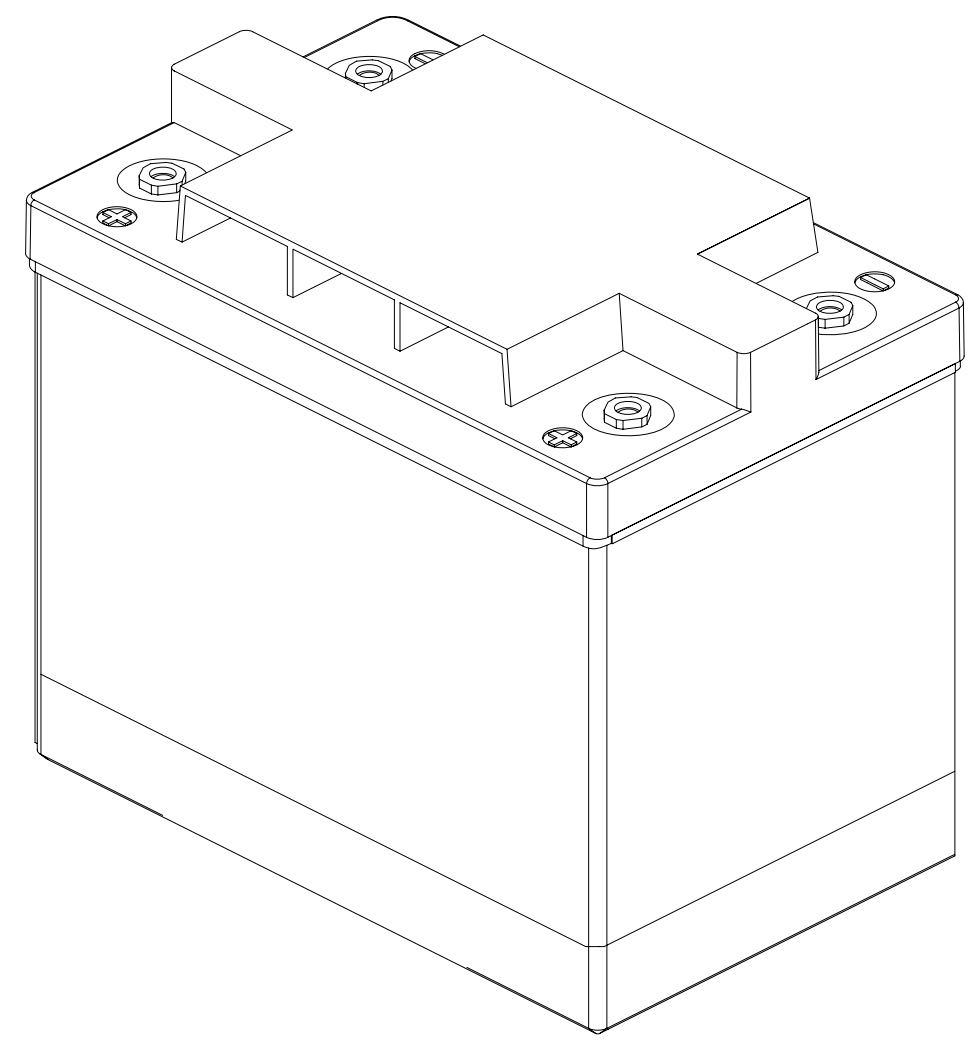
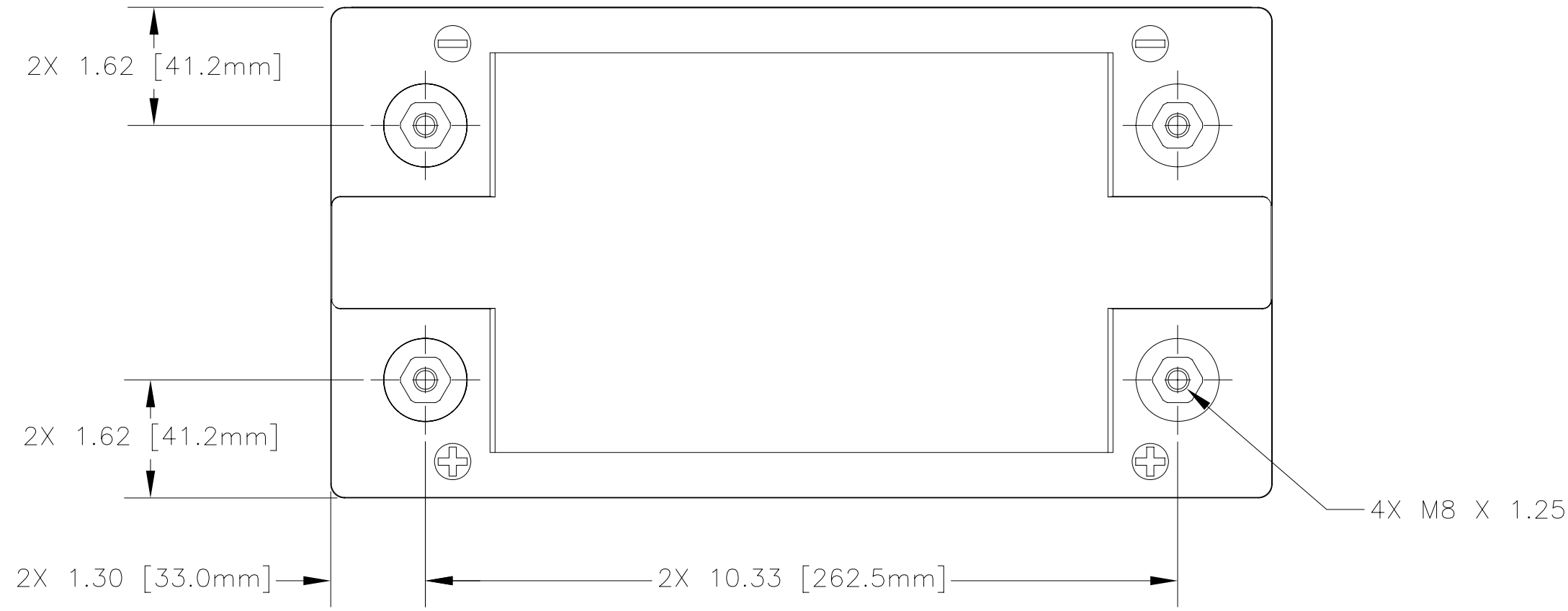

REFERENCE VIEW

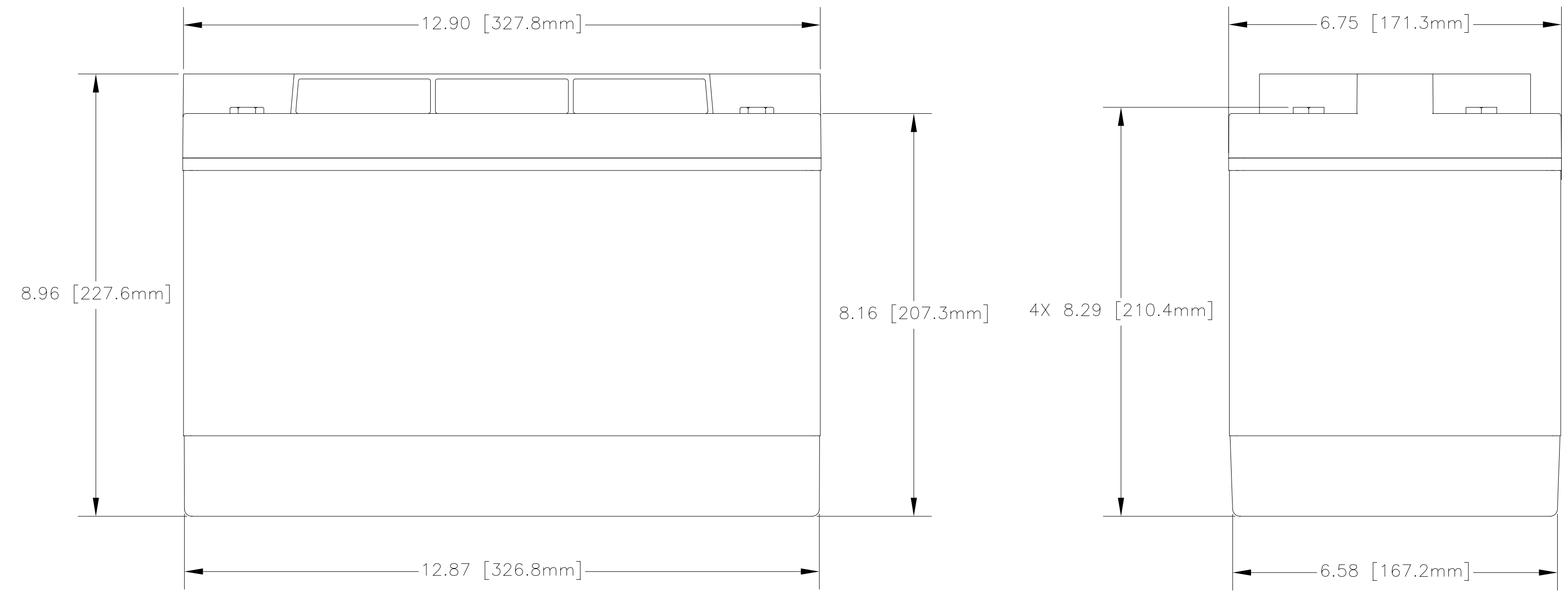

ENVELOPE DRAWING

CAPACITY RATINGS	
PART NUMBER	PVX-7680T
NOMINAL WEIGHT	75 LBS [34.0 KG]
AMPERE HOUR CAPACITY @ 24 HOUR 1.75 VOLTS/CELL @ 77°F (25°C)	768 AH

QTY REQD	CAGE CODE	PART OR IDENTIFYING NO.	NOMENCLATURE OR DESCRIPTION	MATERIAL SPECIFICATION	ITEM NO.
PARTS LIST					
UNLESS OTHERWISE SPECIFIED DIMENSIONS ARE IN INCHES TOLERANCES ARE: FRACTIONS DECIMALS ANGLES ± 1/32 .XX ± .06 ± 1° .XXX ± .030			CONCORDE BATTERY CORPORATION 2009 SAN BERNARDINO RD, W. COVINA, CA 91790		
APPROVALS		DATE		TITLE	
DRAWN D. AYALA		5/16/11		BATTERY, SLA, 2 VOLT, PVX-7680T	
CHECKED AMIII		5/16/11		SIZE	CAGE CODE
APPROVED DV		5/17/11		C	63017
SIMILAR TO NA		ACT WT NA	CALC WT NA	DWG NO.	REV
ISSUED JJ		5/17/11		PVX-7680T	
SCALE NONE				SHEET 1 OF 1	