

IT SERIES

Industrial True Sine Wave AC Power Inverter

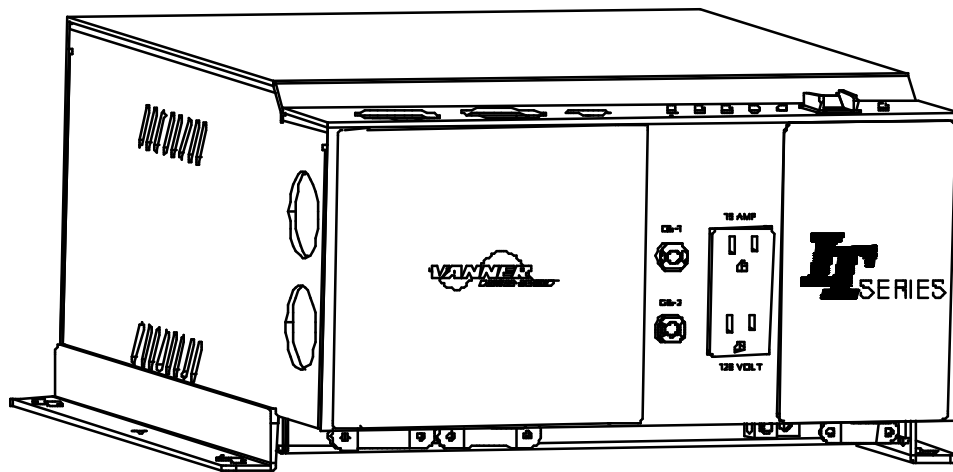

Models

IT12-1400	IT12-2000	IT12-2600	IT12-3200
IT12-1600	IT12-2200S	IT12-2800	IT12-3600PL
IT12-1800	IT12-2400	IT12-3000	IT24-3500

Owners Manual D98494

June 18, 2001

Typical Installation

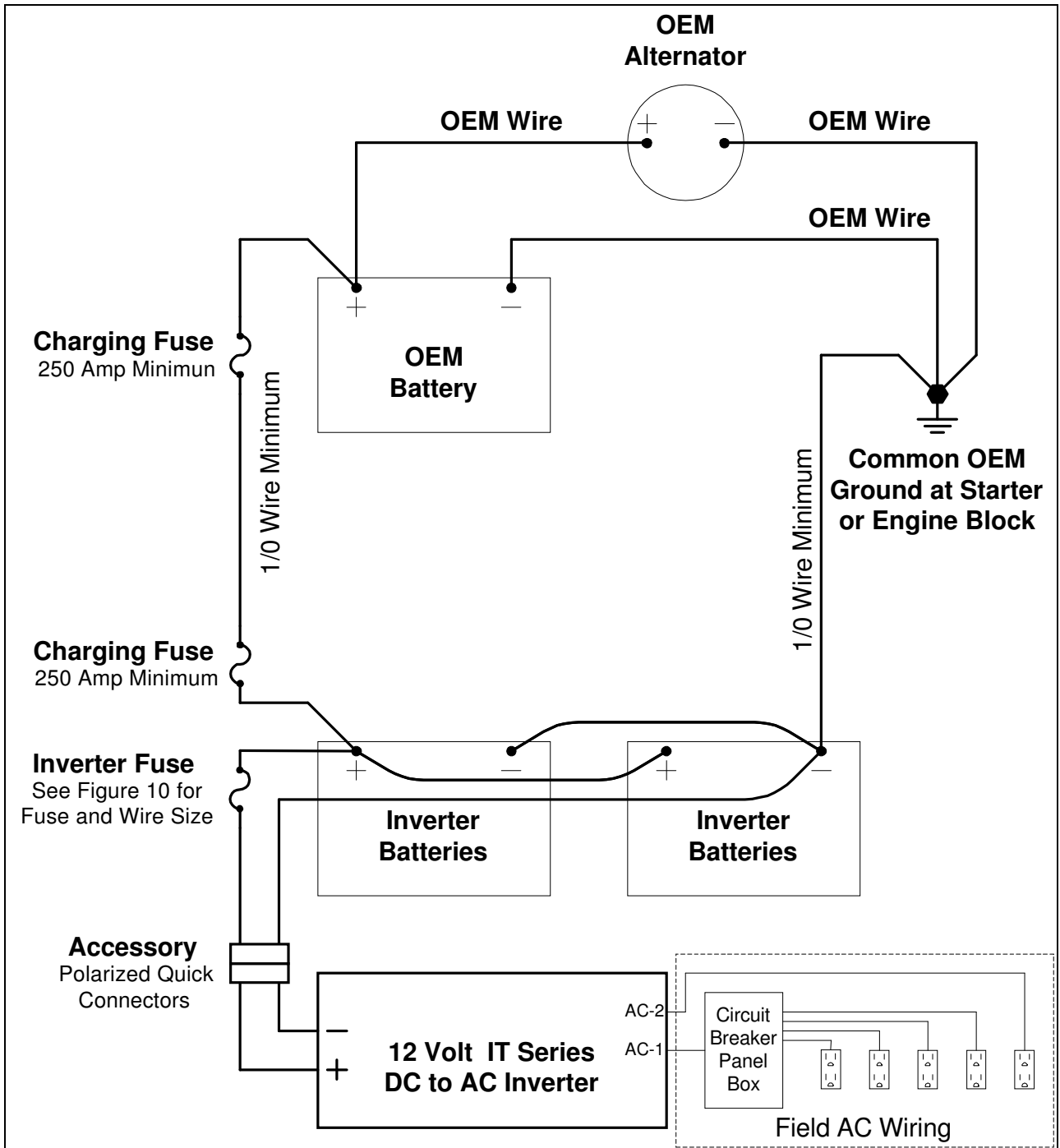

TABLE OF CONTENTS

1	INTRODUCTION	5
2	SPECIFICATIONS AND FEATURES.....	6
	SPECIFICATIONS	6
	STANDARD FEATURES.....	8
	PARTS AND ACCESSORIES	9
3	SAFETY INSTRUCTIONS	10
	README.....	10
	GENERAL PRECAUTIONS.....	10
	EXPLOSIVE GAS PRECAUTIONS	11
	BATTERY PRECAUTIONS	11
4	COMPONENT IDENTIFICATION AND DESCRIPTION OF OPERATION.....	12
(4)	AUTO THROTTLE INDICATOR LIGHT (VOLT GUARD FEATURE)	13
(5)	LOW BATTERY WARNING INDICATOR LIGHT (LOW DC WARNING)	13
(6)	OVERLOAD INDICATOR LIGHT	13
(7)	OVER TEMPERATURE INDICATOR LIGHT.....	13
(8)	LOW BATTERY SHUT DOWN INDICATOR LIGHT (LOW DC)	13
(9)	ON/OFF SWITCH (AND RESET SWITCH).....	13
(10)	INVERTER INDICATOR LIGHT	14
(13)	POSITIVE DC INPUT CONTACT	14
(14)	NEGATIVE DC INPUT CONTACT	14
(16)	CB-2 15 AMP AC OUTPUT CIRCUIT BREAKER.....	15
(17)	CB-1 20 OR 30 AMP AC OUTPUT CIRCUIT BREAKER	15
(18)	CHASSIS GROUND BONDING LUG	15
(20)	AC OUTPUT TERMINAL BLOCK CONTAINING OUTPUTS AC-1 AND AC-2.....	15
(32)	REMOTE CONTROL TERMINAL BLOCK.....	16
(32.1)	Remote ON/OFF Switch Terminals 1, 2 and 3	17
(32.2)	Remote Inverter Indicator Light (LED) Terminals 4 and 5	17
(32.3)	Auto Throttle Control (Volt Guard) Terminal 6	18
(32.5)	Remote Low Battery Warning Terminal 8.....	19
(33)	GFCI DUPLEX RECEPTACLE	19
(35)	COOLING FAN (NOT SHOWN).....	19
5	INSTALLATION AND START-UP	20
	UNPACKING THE INVERTER	20
	INVERTER INSTALLATION CONSIDERATIONS	20
	DC WIRING CONSIDERATIONS	20
	DC WIRING INSTALLATION PROCEDURE	21
	REMOTE CONTROL WIRING INSTALLATION.....	23
	AC OUTPUT WIRING INSTALLATION PROCEDURE	23
	START-UP AND TEST PROCEDURE	23

6	PREVENTIVE MAINTENANCE AND TROUBLE SHOOTING PROCEDURES.....	24
	PREVENTIVE MAINTENANCE.....	24
	TROUBLE SHOOTING PROCEDURES.....	24
7	APPENDIX.....	26
	WARRANTY.....	26
	GFCI TEST RECORD.....	27

List of Figures and Tables

FIGURE 1	SPECIFICATIONS FOR MODELS RATED UP THROUGH 2400 WATTS.	6
FIGURE 2	SPECIFICATIONS FOR MODELS RATED 2600 WATTS AND HIGHER.....	7
FIGURE 3	INVERTER TOP VIEW	12
FIGURE 4	INVERTER FRONT, RIGHT SIDE AND BOTTOM VIEW	14
FIGURE 5	INVERTER FRONT AND LEFT SIDE VIEW	15
FIGURE 6	REMOTE CONTROL TERMINAL BLOCK.....	16
FIGURE 7	REMOTE CONTROL SWITCH WIRING VARIATIONS.....	17
FIGURE 8	AUTO THROTTLE CONTROL DIAGRAM (VOLT GUARD FEATURE)	18
FIGURE 9	REMOTE LOW BATTERY WARNING	19
FIGURE 10	DC CABLE AND FUSE SIZING CHART	21
FIGURE 11	UL LISTED RING TERMINALS FOR DC CABLES	22
FIGURE 12	GFCI TEST RECORD	27

1 INTRODUCTION

Thank you for purchasing a Vanner **IT SERIES** Inverter. We are confident that you will be satisfied with its performance and its many features. With proper installation and care, you can look forward to years of service from this high performance product.

“**IT**” stands for Industrial True Sine Wave.

The **IT SERIES** is a family of dependable inverters designed to meet the severe service requirements of the industrial market. All models of the **IT SERIES** produce true sine wave AC output power.

This document will describe the operation, technical specifications and installation procedures of the various models and accessories offered in this product family. We suggest that you familiarize yourself with the model numbers of the inverter and optional accessories you have purchased before proceeding with this manual. If you require additional information please contact your dealer, or contact us directly at 1-800-227-6937 (800 AC POWER).

WARNING: Before you install and use your **IT SERIES** Inverter be sure to read and save these safety instructions.

Model Listing

The **IT SERIES** product line is designed to meet the requirements of a variety of applications. In order to meet these requirements we offer 12 volt models in 200 watt increments.

NOTICE: All models of the **IT SERIES** use the same front panel and therefore look identical. To identify the model number of your particular unit it is necessary to refer to the Specification Label located on the right side of the unit or to the Identification Label located on the front.

Please note your model and serial number here for future reference.

Model No. _____ Serial No. _____ Date of Installation _____

2 Specifications and Features

Specifications

Figure 1 Specifications for models rated up through 2400 watts.

SPECIFICATIONS	Model Number					
	IT12-1400	IT12-1600	IT12-1800	IT12-2000	IT12-2200S	IT12-2400
AC Power Output						
Rated Output Watts *	1400W	1600W	1800W	2000W	2200W	2400W
Continuous Output	11.7A 1400W	13.3A 1600W	15.0A 1800W	16.7A 2000W	18.3A 2200W	20.0 A 2400W
Surge Output at 3 seconds	22.9A	23.8A	24.7A	25.6A	41.1A	41.6A
Output Waveform	True Sine Wave					
Total Harmonic Distortion	Less than 4% THD for all loads up to surge output					
Output Voltage	120 Volts \pm 5%					
Output Frequency	60 Hz \pm 0.025 Hz (0.04%)					
DC Input Voltage Range	IT12-XXXX = 10.5 - 16.6 VDC / IT24-3500 = 21.0 TO 33.2 VDC					
DC Input Current						
Inverter OFF	1 ma					
Inverter ON in Load Demand Mode (No AC load)	IT12-XXXX = 0.5 amps / IT24-3500 = .255 amps					
Full load at 12VDC	160A	185A	210A	225A	235A	260A
AC Output Wiring Method						
One Built-in Receptacle	GFCI Duplex Receptacle protected by a 15 amp circuit breaker					
Two Hardwire Output Circuits	Output AC-1: protected by a 20 amp circuit breaker on models up through 2400 watts, 30 amp circuit breaker on models 2600 watts and higher					
	Output AC-2 protected by the 15 amp GFCI feedthrough on all units					
System						
Ambient Operating Temperature	-40 to +105° F (-40 to +40° C)					
Cooling Air	Thermostatically controlled intake fan					
Enclosure	White painted aluminum					
Dimensions - All Models	8.0"H x 13.75"W x 15.75"D					
Unit Weight	45 lbs	46 lbs	47 lbs	48 lbs	57 lbs	70 lbs

*Note: The inverter will try to power any load, even a short circuit, for 3 seconds. When the load exceeds the inverter's rated output the Overload Indicator Light will turn ON. After 3 seconds, the inverter will reduce the AC Output Voltage as needed to limit the AC Output Current. If the inverter reduces output voltage below 108 volts for 10 seconds, the inverter will shut itself OFF for Overload.

Figure 2 Specifications for models rated 2600 watts and higher

SPECIFICATIONS	Model Number					
	IT12-2600	IT12-2800	IT12-3000	IT12-3200	IT12-3600PL	IT24-3500
AC Power Output						
Rated Output Watts *	2600W	2800W	3000W	3200W	3600W for 30 minutes minimum**	3500W
Continuous Output	21.7A 2600W	23.3A 2800W	25.0A 3000W	26.7A 3200W	30.0A 3600W	29.2 A 3500W
Surge Output at 3 seconds	42.1A	42.6A	43.2A	43.7A	43.7A	83.0A
Output Waveform	True Sine Wave					
Total Harmonic Distortion	Less than 4% THD for all loads up to surge output					
Output Voltage	120 Volts ± 5%					
Output Frequency	60 Hz ± 0.025 Hz (0.04%)					
DC Input Voltage Range	IT12-XX.XX = 10.5 - 16.6 VDC / IT24-3500 = 21.0 TO 33.2 VDC					
DC Input Current						
Inverter OFF	1 ma					
Inverter ON in Load Demand Mode (No AC load)	IT12-XXXX =0.5 amps / IT24-3500 = .255 amps					
Full load at 12VDC	285A	315A	340A	365A	365A	170A
AC Output Wiring Method						
One Built-in Receptacle	GFCI Duplex Receptacle protected by a 15 amp circuit breaker					
Two Hardwire Output Circuits	Output AC-1: protected by a 20 amp circuit breaker on models up through 2400 watts, 30 amp circuit breaker on models 2600 watts and higher					
	Output AC-2 protected by the 15 amp GFCI feedthrough on all units					
System						
Ambient Operating Temperature	-40 to +105° F (-40 to +40° C)					
Cooling Air	Thermostatically controlled intake fan					
Enclosure	White painted aluminum					
Dimensions - All Models	8.0"H x 13.75"W x 15.75"D					
Unit Weight	71 lbs	72 lbs	73 lbs	75 lbs	75lbs	75 lbs

*Note: The inverter will try to power any load, even a short circuit, for 3 seconds. When the load exceeds the inverter's rated output the Overload Indicator Light will turn ON. After 3 seconds, the inverter will reduce the AC Output Voltage as needed to limit the AC Output Current. If the inverter reduces output voltage below 108 volts for 10 seconds, the inverter will shut itself OFF for Overload.

** At 77° F(25° C) the IT12-3600 can produce 3600 watts for at least 30 minutes before overheating.

Standard Features

1. True sine wave 120 volt AC output.
2. Total harmonic distortion less than 4% for all loads up to the Surge Output Rating.
3. Resilient electronic protection designed to handle output short circuits and output overloads.
4. Built-in Volt Guard Battery Voltage Monitor, providing ground control for an automatic throttle to insure maximum alternator output when needed.
5. Load Demand Feature to conserve DC power under no load conditions.
6. 15 amp GFCI Duplex Receptacle.
7. Two AC output circuits (one GFCI protected) with individual circuit breakers.
8. Terminal block for hardwiring the AC outputs.
9. Automatic shutoff for low or high battery voltage, overload or over temperature.
10. Remote control circuit capable of single wire input (12 or 24 volt input) or 2 wire (12 volt signal and return).
11. Remote indicator light (LED) circuit to operate a remote inverter ON/OFF status LED.
12. Remote Low Battery Warning Circuit, providing ground control for a remote warning device when battery voltage falls to 11.0 (22.0) Volts DC.
13. Terminal block for wiring remote control, remote Inverter ON/OFF LED, remote Low DC Warning device and Auto Throttle control circuits.
14. Indicator lights for Auto Throttle Signal, Low Battery Warning, Low Battery Shutoff, Over Temperature Shutoff, Overload and Inverter ON/OFF/Load Demand status.
15. All controls and wiring connections accessible from the front of the inverter.
16. Thermostatically controlled cooling intake fan.
17. Factory selectable Load Demand ON/OFF. (ON is standard.)
18. Factory selectable Five Minute Automatic Restart after shutdown due to fault. (OFF is standard.)

Definitions

Load Demand Feature and Load Demand Mode:

The Load Demand Feature is an energy conserving feature which allows the inverter to enter the 'Load Demand Mode' whenever the inverter is ON and the AC load has been less than 10 watts for approximately 10 seconds. While in the 'Load Demand Mode' the inverter does not produce 120 volts AC but instead produces pulses of voltage which the inverter uses to look for a load. When a load greater than 10 watts is sensed, the inverter will turn fully ON to produce 120 Volts AC. The 'Load Demand Mode' is often also described as 'stand-by mode' or 'sleep mode'. While in the 'Load Demand Mode' 12-volt models consume approximately 0.5 amps of DC and 24-volt models consume approximately 0.25 amps of DC.

Parts and Accessories

Part Number	Name	Description
03644	Bussmann Fuse ANL-250	250 amp DC fuse for charging cable
04521	Bussmann Fuse ANN-300	300 amp DC input fuse for IT12-1400 thru IT12-2000
04523	Bussmann Fuse ANN-400	400 amp DC input fuse for IT12-2200S
03646	Bussmann Fuse ANL-500	500 amp DC input fuse for IT12-2400 and larger
03637	Bussmann Fuse Holder 4164	Fuse holder for the above DC input fuses
D07923-00	Quick Connect DC Input Cable	18" long 4/0 DC Input Cable with 3/8" ring terminals and polarized 350 amp Quick Connector.
D07923-01	1/0 Quick Connect Cable Set	For use with customer supplied 1/0 DC input cable for IT12-1400 thru IT12-2000. Includes D07923-00 and mating quick connector for 1/0 cable.
D07923-02	2/0 Quick Connect Cable Set	For use with customer supplied 2/0 DC input cable for IT12-1400 thru IT12-2000. Includes D07923-00 and mating quick connector for 2/0 cable.
D07923-03	3/0 Quick Connect Cable Set	For use with customer supplied 3/0 DC input cable for IT12-1400 thru IT12-2200S. Includes D07923-00 and mating quick connector for 3/0 cable.
D07923-04	4/0 Quick Connect Cable Set	For use with customer supplied 4/0 DC input cable for all IT models. Includes D07923-00 and mating quick connector for 4/0 cable.
D08403	DC Input Compressing Fitting Kit	Includes 2) D08241 Compression Fittings and Installation Diagram D98403. Accepts DC input cables up to 250MCM.
D08506	Remote Switch Assembly	SPST Toggle Switch, 25 foot long cable, 1amp fuse and fuse holder.
73-46	Automatic Throttle	Vanner Automatic Throttle for mechanical throttle linkages. (The 73-46 does not apply to electronic engines having no mechanical linkage to the accelerator pedal.)
05235	12 volt 30 amp Bosch Relay	Automotive 12 volt SPDT relay with 30 amp contacts.
D08546	20 Amp AC Output Cord Set	NEMA L5-20R receptacle (120 volt, 20 amp, twist-lock) on 1' long 12/3 SO cable with ring terminals and includes a mating NEMA L5-20P plug.
D07924	30 Amp AC Output Cord	NEMA L5-30R receptacle (120 volt, 30 amp, twist-lock) receptacle on 1' long 10/3 SO cable with ring terminals.

3 SAFETY INSTRUCTIONS

README

WARNING: Before you install and use your *IT SERIES AC Power Inverter*, be sure to read and save these safety instructions.

This manual contains important safety and operating instructions for the Vanner Power Group IT SERIES Power Inverter as prescribed by Underwriters Laboratories (UL). The IT SERIES inverter is listed as compliant with UL 458, Power Converters/Inverters and Power Converter/Inverter Systems, and UL 1741 Power Conditioning Units for use in Residential Photo-voltaic Power Systems. The IT SERIES is also listed in the Canadian National Standard CSA – C22.2 No. 107.1957.

NOTICE: The output waveform of the IT SERIES inverter is sinusoidal. Total harmonic distortion is less than four percent.

CAUTION: Read owners manual BEFORE wiring or powering up.

CAUTION: Not intended for DC input directly from a solar array. Batteries must be used.

CAUTION: DO NOT cover or obstruct ventilation openings. DO NOT mount in a zero-clearance compartment. Overheating may result.

WARNING: Under high ambient temperature / high-power-output conditions some parts of the inverter may become hot enough to cause burns. The unit should be installed so that it is not to be contacted by personnel.

WARNING: This equipment employs components that tend to produce arcs and sparks. To prevent fire or explosion, DO NOT install in confined areas or compartments that contain batteries or flammable materials.

WARNING: Improper use of this product may result in risk of electrical shock. Both AC and DC voltage sources are terminated inside this equipment.

Use only the ground fault circuit interrupter (GFCI) receptacle(s) or circuit breaker(s) specified in the installation and operating instructions. Other types may fail to operate properly when connected to this equipment.

DANGER: Battery connections are for disconnect only, NOT for current interruption.

General Precautions

1. Do not expose the inverter to direct water spray or snow.
2. To reduce the risk of a fire hazard, do not cover or obstruct the ventilation openings.
3. Do not install the inverter in a zero clearance compartment. This may result in overheating or diminished performance.
4. To avoid the risk of fire, electrical shock, or injury to persons, do not use attachments not recommended or sold by the Vanner Power Group.
5. Vanner recommends that all AC and DC electrical wiring be performed by a licensed electrician or a qualified technician to ensure compliance with all applicable national and local wiring regulations.
6. To avoid a risk of fire and/or electrical shock, always verify wiring connections are in good electrical condition. All external conductors must use proper wire size to avoid dangerous overheating or diminished performance.
7. If the inverter has been dropped or damaged in any way, do not operate the inverter until it has been verified to be safe by a qualified technician.

8. To reduce the risk of electrical shock, always disconnect the AC and DC connections to the inverter before attempting any maintenance. Simply turning the inverter off does not prevent electrical shock.
9. The inverter must be properly grounded in accordance with local and national codes and ordinances before operation. For most installations, the negative (ground) conductor should be bonded to the grounding system at one and only one point in the system.
10. For optimum inverter performance, battery temperature should be above 32 degrees Fahrenheit.
11. Do not disassemble the inverter. See the service section of this manual for instructions on obtaining service. Attempting to service the inverter yourself may result in a risk of electrical shock, fire and/or loss of warranty.

Explosive Gas Precautions

1. This equipment contains components, which tend to produce arcs or sparks. To prevent fire or explosion, do not install in compartments containing batteries or flammable materials, or in locations that require ignition protected equipment. This includes any space containing gasoline-powered machinery, fuel tanks, or joints, fittings, or other connections between components of the fuel system.
2. To reduce the risk of battery explosion, follow these instructions, the battery manufacturer instructions, and the instructions of the manufacturer of the equipment in which the battery is installed. Working near a lead-acid battery is dangerous. Batteries generate explosive gases during normal battery operation.

Battery Precautions

1. Always have someone within range of your voice to come to your aid when you work near a lead-acid battery.
2. Have close access to plenty of fresh water and soap in case battery acid contacts skin, clothing, or eyes.
3. Always wear complete eye protection and clothing protection. Avoid touching eyes while working near batteries.
4. If battery acid contacts skin or clothing, wash immediately with soap and water. If acid enters eye, immediately flood eye with running cold water for at least 20 minutes. Get medical attention immediately.
5. NEVER smoke or allow a spark or flame near a battery. Gases produced by batteries are explosive.
6. Be careful when working with metal tools around batteries. Potentials exist for sparks or short-circuit of the battery or other electrical part which could cause an explosion.

4 COMPONENT IDENTIFICATION and DESCRIPTION of OPERATION

Figure 3 Inverter Top View

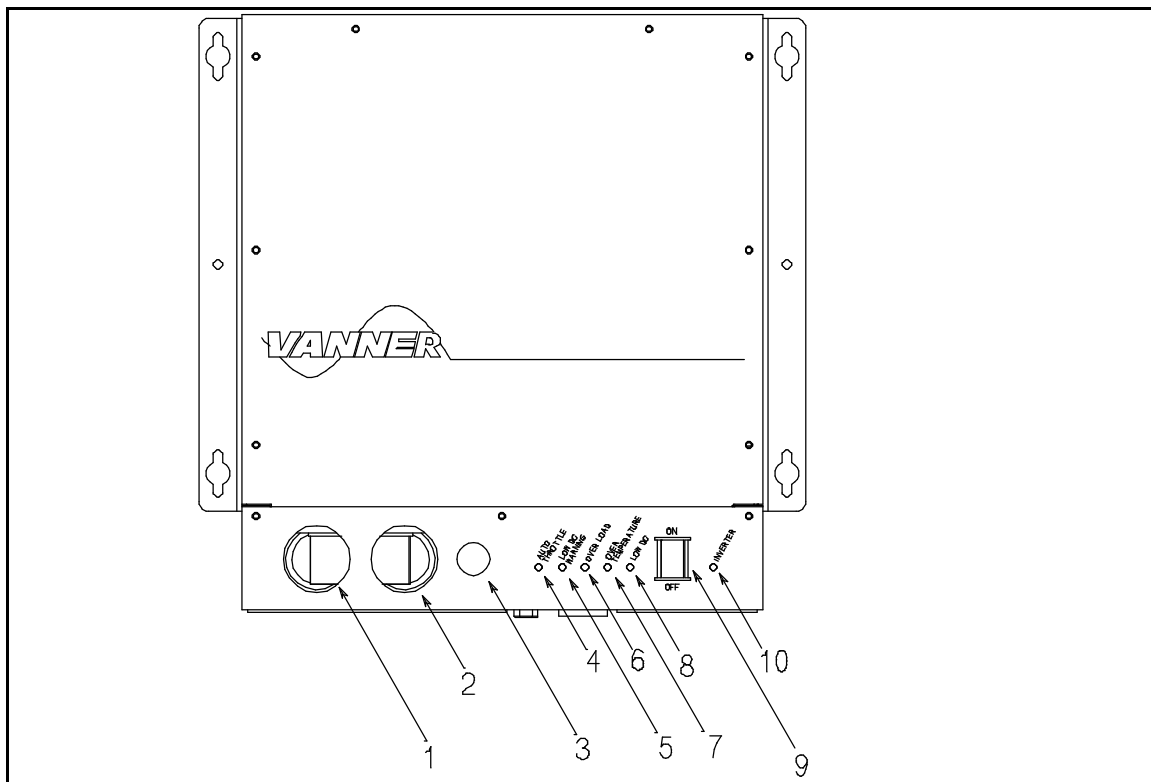

- (1) Top entry for positive DC input cable
- (2) Top entry for negative DC input cable
- (3) Top entry for Remote Control Terminal Block

(4) Auto Throttle Indicator Light (Volt Guard Feature)

(see also item (32.3) Terminal 6 Auto Throttle Control Terminal)

<u>Light Display</u>	<u>Description</u>
----------------------	--------------------

Green Light is ON	The Auto Throttle Signal (ground signal) is ON due to battery voltage remaining below 12.6 (25.2) volts for 15 seconds. The Indicator Light and the Auto Throttle Signal will remain ON until battery voltage remains above 13.8 (27.0) volts for 15 seconds. The indicator light will also remain ON at full load output.
-------------------	--

The **Volt Guard Feature** is designed to control an automatic throttle on vehicles where the inverter is required to operate continuous, heavy AC loads. By controlling the auto throttle the Volt Guard Feature will insure that the vehicle's alternator operates at maximum output when needed.

The Volt Guard circuit is designed to provide 'ground control' for a Bosch relay, Vanner part number 05235 or equal. Use the Bosch relay to operate the automatic throttle, Vanner 73-46 Automatic Throttle or equal. See Figure 5 for details and Figure 7 for a schematic diagram.

(5) Low Battery Warning Indicator Light (Low DC Warning)

<u>Light Display</u>	<u>Description</u>
----------------------	--------------------

Yellow Light is ON	The inverter is ON and battery voltage has decreased to less than 11 (22) volts DC. Automatic inverter shutdown for low battery at 10.5 (21) volts is imminent unless the battery voltage is increased.
--------------------	---

(6) Overload Indicator Light

<u>Light Display</u>	<u>Description</u>
----------------------	--------------------

Solid Red	The inverter is ON but the inverter's AC output circuitry is sensing an overload condition. If the AC load is not reduced, the inverter will shut itself OFF after approximately 12 seconds.
-----------	--

Blinking Red	The inverter has shut itself OFF due to overload. The Inverter ON/OFF Switch must be cycled to reset and restart the inverter.
--------------	--

(7) Over Temperature Indicator Light

<u>Light Display</u>	<u>Description</u>
----------------------	--------------------

Blinking Red	The inverter has shut itself OFF due to over temperature. The Inverter ON/OFF Switch must be cycled to reset and restart the inverter.
--------------	--

(8) Low Battery Shut Down Indicator Light (Low DC)

<u>Light Display</u>	<u>Description</u>
----------------------	--------------------

Blinking Red	Battery voltage has fallen below 10.5 volts (21 volts) and the inverter has shut itself OFF. The Inverter ON/OFF Switch must be cycled to reset and restart the inverter.
--------------	---

(9) ON/OFF Switch (and RESET Switch)

The ON/OFF Switch is a two-position rocker switch used to turn the inverter ON/OFF and is used as a RESET Switch. When the inverter has automatically shut itself OFF due to a fault, the inverter must be RESET by turning the ON/OFF Switch OFF or by turning a remote switch OFF. (If an automatic shutdown has occurred due to a fault, one of the fault indicator lights will be displayed until the inverter is RESET.)

(10) Inverter Indicator Light

Light Display	Description
Green Light is OFF	Inverter is OFF
Solid Green	Inverter is ON and is producing AC power
Blinking Green	Inverter is in Load Demand Mode

Figure 4 Inverter Front, Right Side and Bottom View

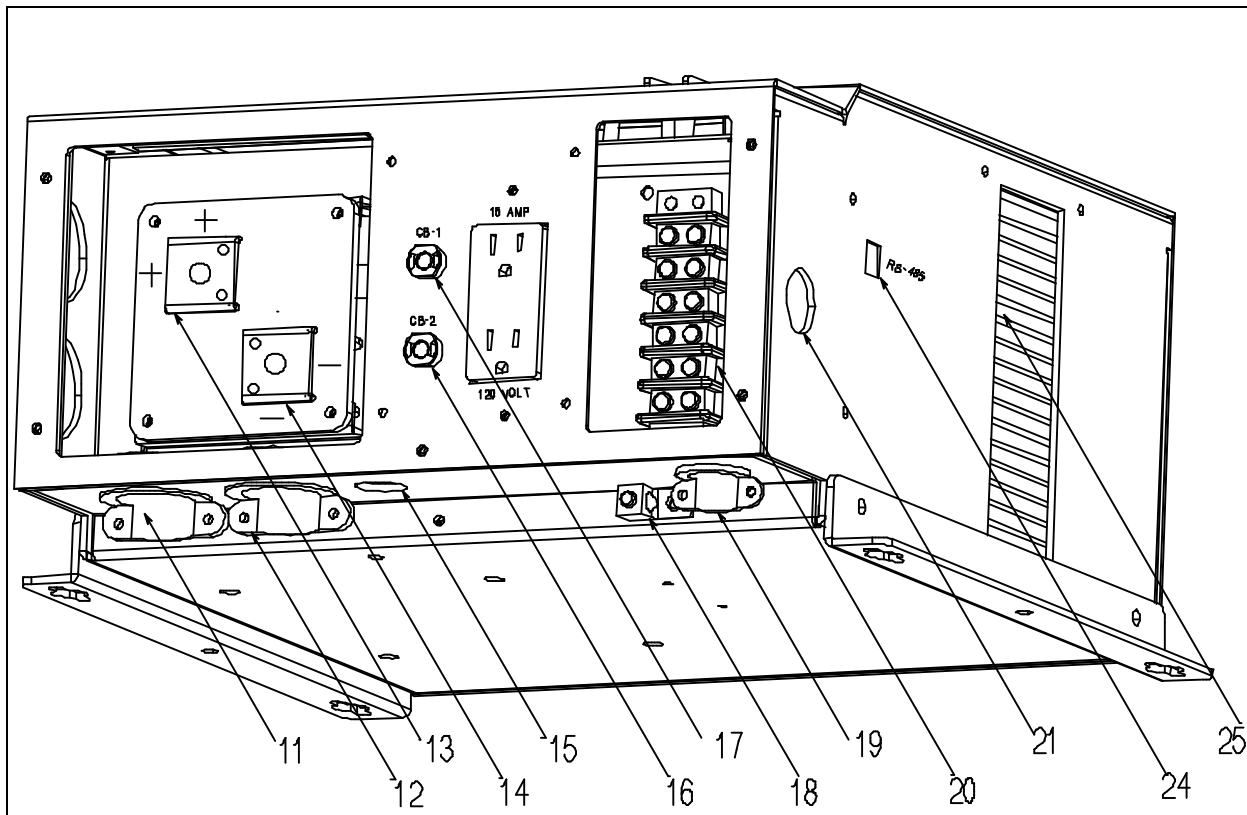

- (11) Bottom entry for positive DC input cable**
- (12) Bottom entry for negative DC input cable**
- (13) Positive DC Input Contact**
- (14) Negative DC Input Contact**
- (15) Bottom entry for Remote Control Terminal Block**

(16) CB-2 15 Amp AC Output Circuit Breaker

CIRCUIT BREAKER CB-2 (bottom breaker) protects the GFCI Receptacle and AC Output AC-2.

(17) CB-1 20 or 30 Amp AC Output Circuit Breaker

CIRCUIT BREAKER CB-1 (top breaker) protects AC Output AC-1. CB-1 is a 20 amp breaker on models up through 2400 watts. CB-1 is a 30 amp breaker on models rated 2600 watts and higher.

(18) Chassis Ground Bonding Lug

(19) Bottom entry for AC output cable

(20) AC Output Terminal Block containing outputs AC-1 and AC-2

(21) Side entry for AC output cable

(22) N/A

(23) N/A

(24) Factory set-up jack

(25) Air Exhaust Vents

Figure 5 Inverter Front and Left Side View

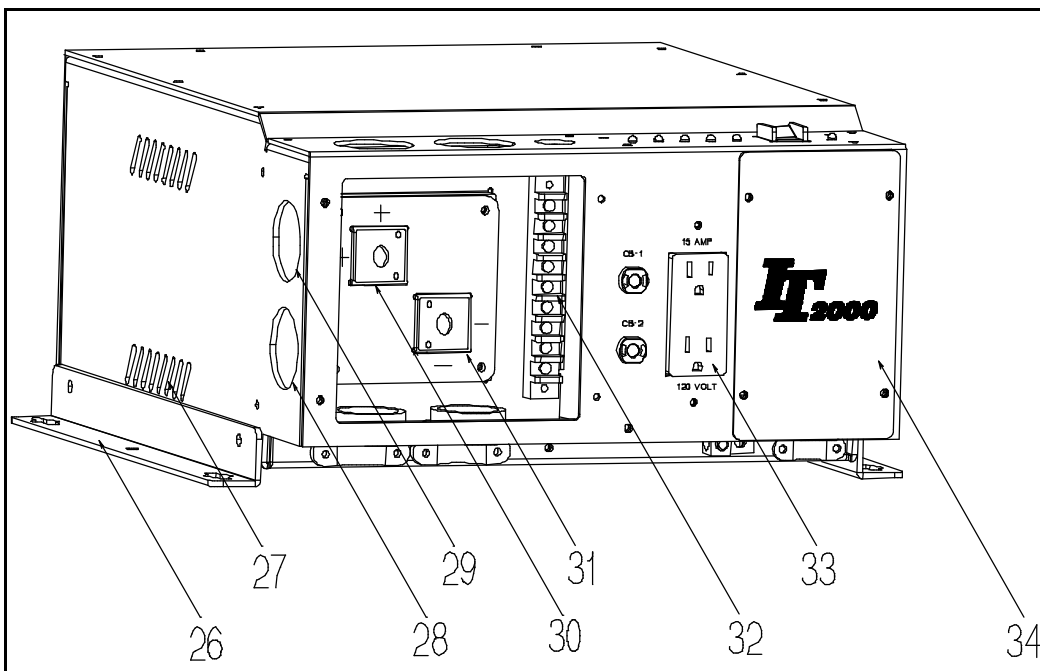

- (26) Mounting Brackets (2)
- (27) Air Exhaust Vents
- (28) Side entry for negative DC input cable
- (29) Side entry for positive DC input cable
- (30) Positive DC Input Contact
- (31) Negative DC Input Contact
- (32) Remote Control Terminal Block

A 9-position terminal block is provided for connecting optional, customer supplied remote control and remote display wiring. Please note that any wiring to this terminal block is optional.

Figure 6 Remote Control Terminal Block

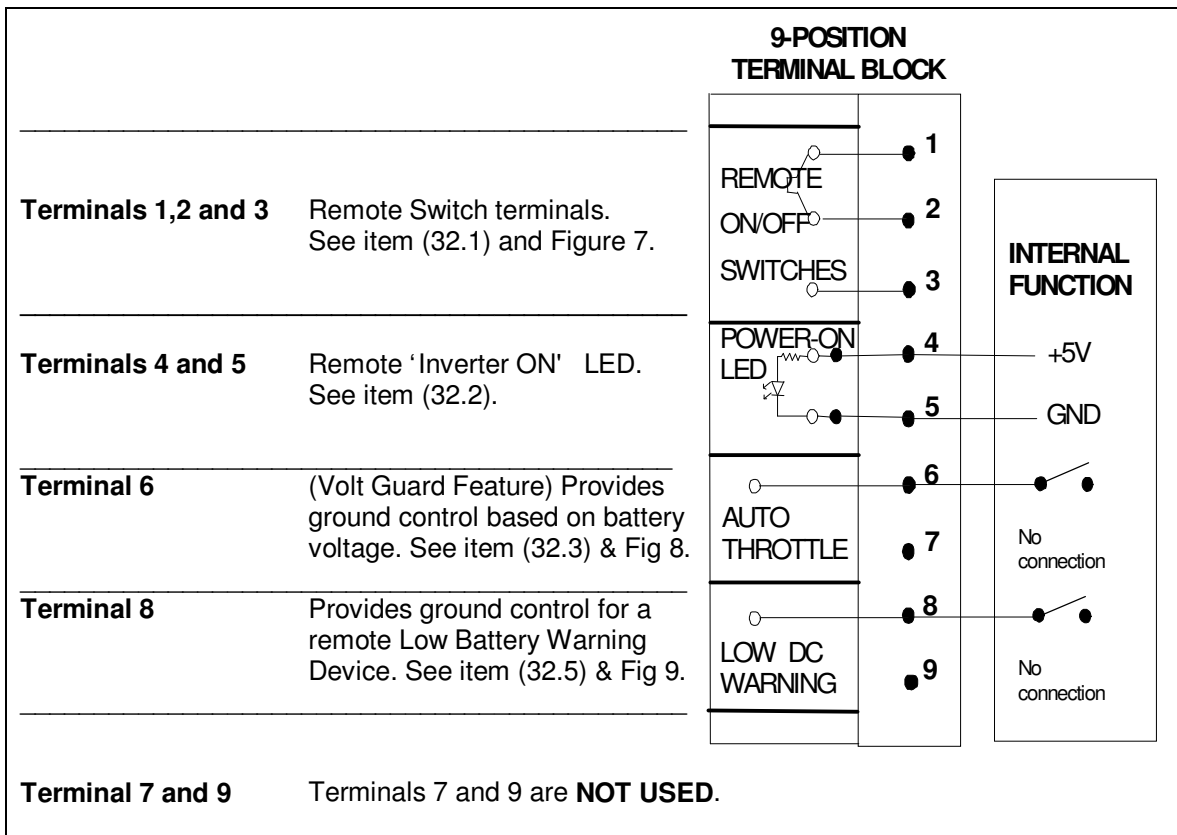

(32.1) Remote ON/OFF Switch Terminals 1, 2 and 3

The IT SERIES Inverter allows four styles of remote control wiring for customers who wish to supply and install a remote control switch or switches.

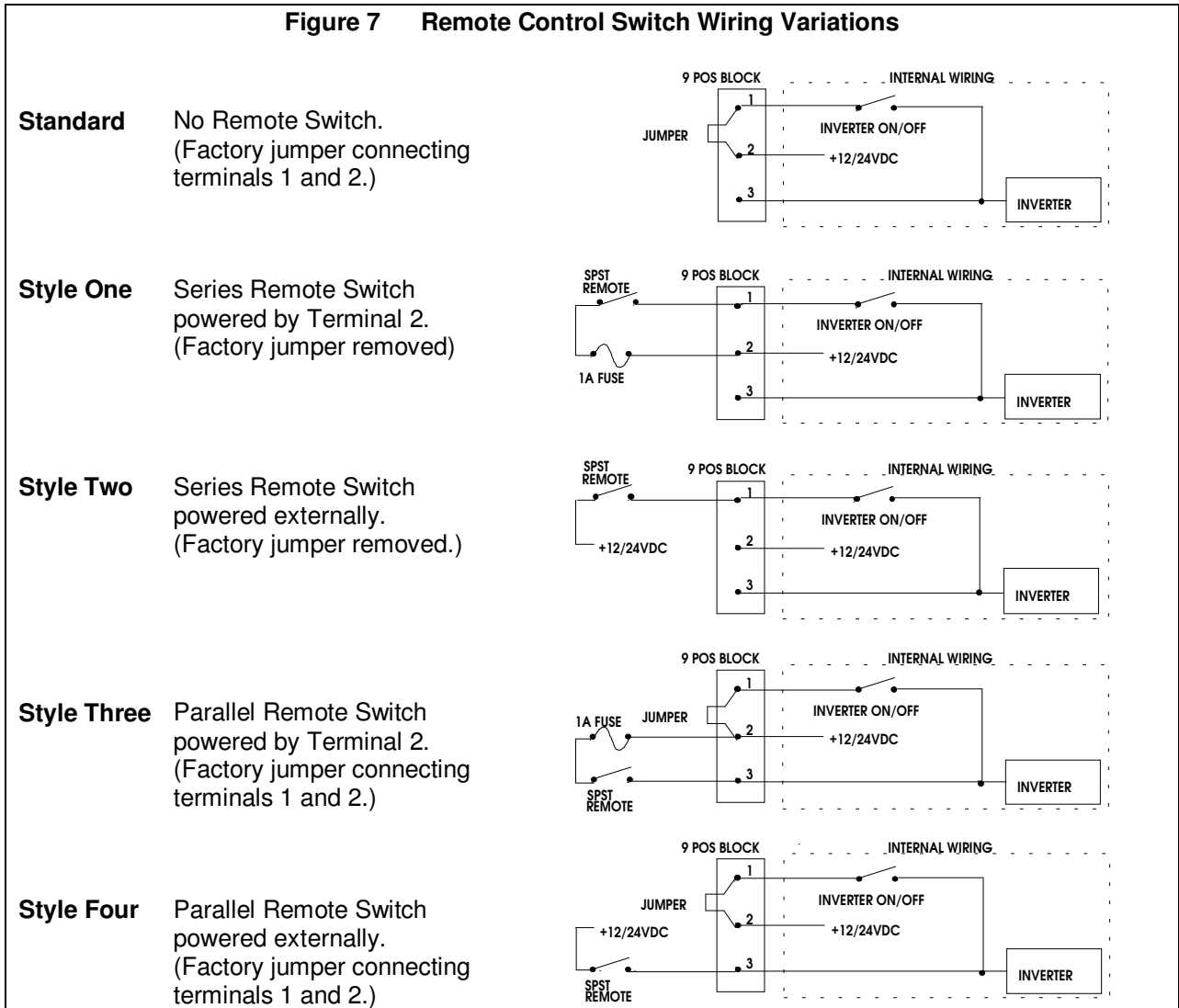

(32.2) Remote Inverter Indicator Light (LED) Terminals 4 and 5

(See also item (10) Inverter Indicator Light

Use Terminals 4 and 5 to operate a customer supplied remote Inverter LED through a 470-ohm resistor. The LED will light when the inverter is ON or in Load Demand Mode. A remote Inverter LED does not blink when the inverter is in Load Demand Mode.

(32.3) Auto Throttle Control (Volt Guard) Terminal 6

(See also item (4) Auto Throttle Indicator Light)

The Auto Throttle Control (Volt Guard Feature) provides a ‘ground signal’ at Terminal 6 and turns ON the Auto Throttle Indicator Light whenever battery voltage remains below 12.6 (25.2) volts for more than 15 seconds. The ‘ground signal’ and the indicator light both turn OFF after battery voltage remains above 13.8 (27.0) volts for 15 seconds. The circuit is designed to provide ‘ground control’ for a Bosch relay, Vanner part number 05235 or equal.

Use the Volt Guard Feature to control an automatic throttle on vehicles where the inverter is required to operate continuous heavy AC loads or where other heavy DC loads are present. By controlling the auto throttle in reference to battery voltage, the Volt Guard Feature insures that the vehicle alternator produces maximum output when needed.

Use the Bosch relay to control the automatic throttle, Vanner 73-46 Automatic Throttle or equal. **Install a ½ amp in-line fuse near the inverter as shown.** The sketch below follows the 73-46 Automatic Throttle wiring instructions as for a Dynamic Inverter installation. This requires separating the input *signal* circuit from the input *power* circuit by cutting the Red 18GA jumper on the Auto Throttle Control Module. The Bosch relay may also control the Auto Throttle via the ground similar to the Volt Guard circuit shown in the 73-46 Auto Throttle instructions. For ground control, route the Auto Throttle’s white/black wire through the Bosch relay’s N.O. contacts.

Figure 8 Auto Throttle Control Diagram (Volt Guard Feature)

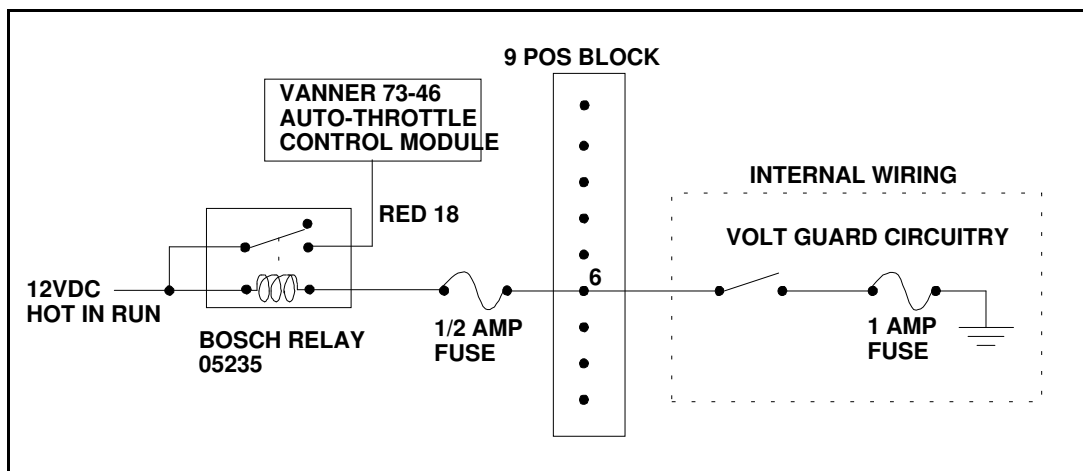

(32.4) Terminal 7 Not used.

(32.5) Remote Low Battery Warning Terminal 8

(See also item (5) Low Battery Warning Indicator Light (Low DC Warning))

Terminal 8 is designed to provide ground control for a Bosch relay, Vanner part number 05235 or equal, to operate in conjunction with the Low DC Warning Indicator Light. Use the Bosch relay to operate an audible alarm, lights or other warning device. The warning will alert personnel that battery voltage has fallen to 11 (22) volts and automatic inverter shut down for low battery voltage at 10.5 (21) volts is imminent.

Install a ½ amp in-line fuse near the inverter as shown.

Figure 9 Remote Low Battery Warning

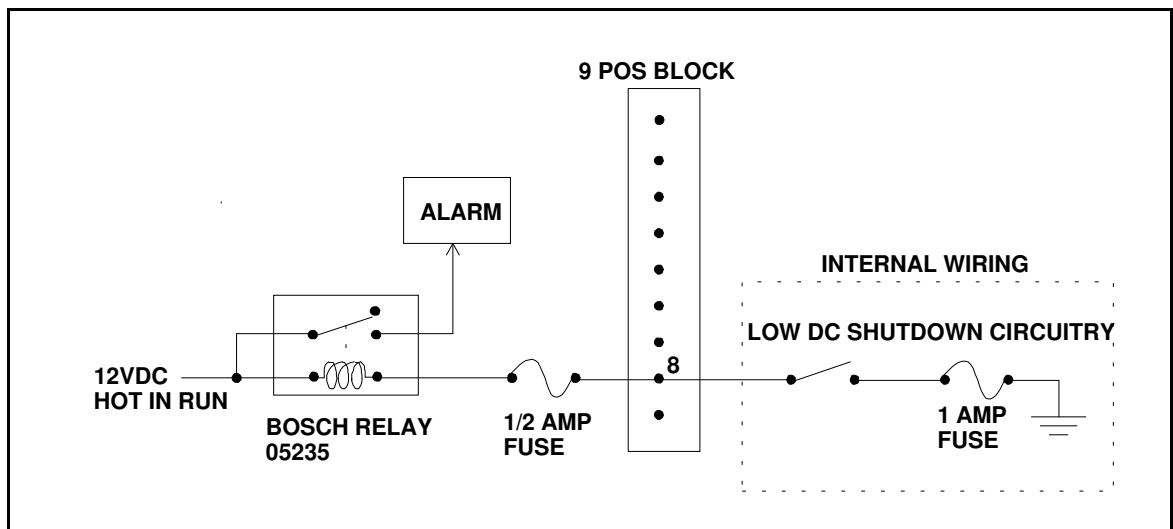

(32.6) Terminal 9 Not used.

(33) GFCI Duplex Receptacle

The GFCI is protected by 15 amp Circuit Breaker CB-2 and protects terminal block Output AC-2.

(34) AC Output Wiring Compartment

(35) Cooling Fan (Not shown)

The cooling air intake fan is located on the back of the inverter. Air is drawn in at the back of the inverter and is exhausted on both sides. Allow a minimum of 1½" clearance (40 mm) at the back of the inverter and on both sides to insure proper cooling.

5 INSTALLATION and START-UP

Unpacking the Inverter

1. Inspect the shipping container and equipment for loose or damaged parts. If any damage is found, immediately notify the freight carrier.

Inverter Installation Considerations

1. **Mounting:** Locate a secure, dry, flat horizontal or vertical surface large enough to mount the inverter. The location should be as close to the battery as possible, usually within six feet, but not in the same compartment and should provide adequate ventilation while the inverter is operating. The location must be clean, dry and free from road spray, dripping water or other moisture contamination.
2. **Cooling Fan Clearance:** The mounting location must allow unobstructed airflow for cooling. Allow a minimum clearance of 1½ inches (40 mm) on the left, right and back sides of the inverter. The Cooling Fan is a thermostatically controlled intake fan. Air is drawn into the inverter from the backside and exhausted through vents on the left and right sides. Obstruction of the fan intake or the exhaust vents will diminish the inverter output capacity due to overheating.

DC Wiring Considerations

1. **A DC FUSE IS REQUIRED** to properly protect the inverter in case the battery cables are connected backward (reverse polarity).
2. The wiring of your inverter installation should conform to the National Electric Code (NEC) and any other state or local codes in effect at the time of installation. These codes have been written for your protection and their requirements should be followed. Article 551 of the NEC requires any DC cable from a battery, which measures longer than 18 inches along its length, be protected by a fuse.
3. **BE AWARE**, as a large number of capacitors become charged upon completion of the DC circuit, **THERE WILL BE A LARGE SPARK** when the last battery connection is made. The spark is normal and will occur every time the batteries are connected. It is advisable to make the last DC connection at the input fuse, not at the battery, to reduce the risk of battery explosion.
4. Route the AC output wiring and DC power wiring with as much physical separation as possible from low voltage wiring such as audio and video signal wires.
5. Route the DC positive and negative cables as close together as possible and use cable ties to keep them together. This reduces electromagnetic radiation that could interfere with sensitive electronics.
6. If passing through steel or other ferrous metal walls, the DC input cables need to pass through the same hole to prevent causing a transformer effect. If two holes are required, cut a slot to connect the two holes to prevent heating of the ferrous metal.

7. **Proper DC cable size is critical** for the performance and safe operation of the inverter system. *The DC Cable and Fuse Sizing Chart* shows the minimum recommended cable sizes. These sizes allow a ½ volt maximum voltage drop at maximum inverter capacity and will insure optimum inverter performance. Quick DC cable connectors are available. See Parts and Accessories.
8. Do not use the vehicle chassis as the DC negative conductor. The negative cable should be the same size as the DC positive cable and should be connected directly to the battery negative terminal.
9. DC cables should be as short as possible.

Figure 10 DC Cable and Fuse Sizing Chart

Model Number	IT12-1400	IT12-1600	IT12-1800	IT12-2000	IT12-2200S	IT12-2400	IT12-2600	IT12-2800	IT12-3000	IT12-3200	IT12-3600PL	IT24-3500
Cable Size	Distance from battery to inverter in feet (Length of cable needed is 2 times the distance.)											
1/0	12	11	10	9	NR	NR	NR	NR	NR	NR	NR	NR
2/0	16	13	12	11	NR	NR	NR	NR	NR	NR	NR	NR
3/0	20	16	15	14	14	NR	NR	NR	NR	NR	NR	NR
4/0	20	20	19	18	17	15	14	13	12	11*	10*	11
250MCM	20	20	20	20	20	17	16	16	14	13*	12*	13
Fuse (Bussmann) Vanner part number	ANN300 04521			ANN400 04523		ANL500 03646						
Fuse Holder	Vanner part number 03637 (Bussmann 4164)											

*For 12 volt models rated-2800 watts and higher use cable rated 90°C, UL listed 4/0 cable 03558, or equal.
 Note: A 500 amp fuse is required to achieve *full surge output capacity* on Model IT24-3500. Usage of the 500 amp fuse dictates using 4/0 cable or larger.

DC Wiring Installation Procedure

1. The DC wiring enclosure is located on the left front of the inverter. The DC cables may enter the inverter through top, bottom or left side openings (see figures 1,2,and 3). Two cable clamps and four plastic hole plugs are provided. Bolts are provided for connecting 5/16 diameter ring terminals to the DC Input Contacts. Optional compression lugs (Vanner part no. D08241) are available for cables sizes up to 250 MCM.
2. Select a location for the inverter. An ideal location is close to the battery; protected from weather and moisture; and well ventilated.
3. Select an accessible location for the DC Fuse. The location should be within 18” of the battery and accessible for visual inspection and replacement. If possible locate so the last DC connection can safely be made at the fuse.

4. Remove the cover plate on the DC cable compartment to expose the positive and negative DC contacts and the Remote Control Terminal Block.
5. Prepare DC cable ends. Use ring terminals or, if using the optional D08241 Compression Lugs, leave the cable ends bare.

Figure 11 UL Listed Ring Terminals for DC Cables

Wire Gauge	Molex Part No.	Ring Size	Molex Description	Recommended Crimp Tools	
				Molex Brand	AC Terminals Inc Brand
1/0	H-381-56	5/16	Versacrimp*	DLHH, PPDLH, SKT-840	Crimp Master 0280
	H-791-56		Nylacrimp	DLHH, PPDLH	
	H-981-56		Funnel Nylacrimp	DLHH, PPDLH	
2/0	J-385-56	5/16	Versacrimp*	DLHH, PPDLH, SKT-840	Crimp Master 0280
	J-785-56		Nylacrimp	DLHH, PPDLH	
	J-985-56		Funnel Nylacrimp	DLHH, PPDLH	
3/0	K-390-56	5/16	Versacrimp*	DLHH, PPDLH, SKT-840	Crimp Master 0280
	N/A		Nylacrimp	DLHH, PPDLH	
	K-990-56		Funnel Nylacrimp	DLHH, PPDLH	
4/0	L-395-38	3/8	Versacrimp*	DLHH, PPDLH, SKT-840	Crimp Master 0280
	N/A		Nylacrimp	DLHH, PPDLH	
	L-995-38		Funnel Nylacrimp	DLHH, PPDLH	

*Require shrink wrap insulation applied to barrel: 1/0 to 2/0 use Molex PFV-3/4, 3/0 to 4/0 use PFV-1.
 Molex telephone number 813-521-2700. AC Terminal telephone number 614-868-9828.

6. Verify that the battery positive cable is not connected to the battery. Insert DC cables through the strain reliefs and into the DC wiring compartment. Torque DC cable mounting bolts to 180 inch pounds. Re-torque after 30 days. (If using the optional D08421 Compression Lugs, torque the Allen mounting screw to 180 inch pounds and the Allen compression screw to 240 inch pounds. Re-torque after 30 days.) Tighten the two strain relief cable clamps. Insert the four plastic plugs into the unused cable openings.
7. Inspect the DC cable compartment to be sure no copper wire fragments are present after tightening cables.
8. Route the negative DC cable to the battery. Verify cable polarity before proceeding. The fuse will be blown and inverter can be damaged if the DC cables are reversed. Route the positive DC input cable to the fuse and then to the battery. Protect cables with loom and use grommets or other appropriate means where cables may contact hard, sharp edges. If possible, make the last DC connection at the fuse to avoid causing a spark at the battery.
9. Connect Chassis Ground Bonding Lug to the vehicle chassis and/or earth ground using AWG No.8 or larger copper conductor.
10. Verify that the inverter will turn ON but do not leave the inverter connected to the battery at this time (remove the fuse). Final battery connections will be made after all control and AC output installation issues have been inspected.

Remote Control Wiring Installation

1. Refer to the wiring sketches found in the Component Identification and Description of Operation section, item (32), Remote Control Terminal Block. Use fuses where indicated.
2. Use cable clamp provided to secure wiring. A plastic plug is provided for the unused opening.

AC Output Wiring Installation Procedure

WARNING: Before proceeding with the AC wiring, verify that the inverter is OFF and that the inverter is NOT connected to the battery. Serious or fatal electrical shock may occur.

1. The wiring of your inverter installation should conform to the National Electric Code (NEC) and any other state or local codes in effect at the time of installation. These codes have been written for your protection and their requirements should be followed
2. Route the AC output wiring, and DC power wiring, with as much physical separation as possible from low voltage wiring such as audio and video signal wires.
3. Remove the right front cover to expose the AC wiring compartment and the AC Output Wiring Terminal Block. Output Circuits AC-1 and AC-2 are identified on the terminal block label and are defined in Section 2, items 16, 17 and 20.
4. A cable clamp is provided to secure the AC output wiring. A plastic plug is provided to plug the unused opening.
5. Verify AC wiring installation. Verify that all connections are tight. Secure all wiring.

Start-up and Test Procedure

After the inverter has been properly mounted with sufficient ventilation, DC cables have been connected to the inverter (but not yet to the battery), AC wiring has been completed, and all remote connections have been checked; the Start-up and Testing procedure should be performed.

WARNING: These procedures are to be performed only by a QUALIFIED INSTALLER.

Inverter Start-up and Testing

1. Place the Inverter ON/OFF switch in the OFF position.
2. Place any remote switches in the OFF position.
3. Verify that any external AC output circuit breakers and GFCI receptacles are reset.
4. Connect the battery to the inverter. **BE AWARE**, as a quantity of capacitors become charged upon completing the DC circuit, **THERE WILL BE A LARGE SPARK** when the last connection is made.
5. Turn the inverter ON and use a test load (75 watt trouble light) plugged into the 15 amp GFCI receptacle to verify the inverter produces AC power.
6. Refer to the description of operation of the indicator lights, Section 2, items 4 through 10 to follow and verify correct inverter operation.
7. If the inverter is not operating as described, see Trouble Shooting Procedures

6 Preventive Maintenance and Trouble Shooting Procedures

There are no user serviceable components inside the inverter. If the inverter requires service, refer to the Vanner Power Group or other qualified service personnel.

Preventive Maintenance

For continued reliability and safety, a monthly maintenance program should be implemented to include the following:

1. Check to insure that all wiring connections are tight, secure and corrosion free.
2. Check fan intake and exhaust vents for obstructions.
3. Examine receptacle, indicators and switches for cracks and breaks.
4. Examine any surfaces that are discolored or deformed due to excessive heat.

Trouble Shooting Procedures

The following are the most common questions heard by Vanner service professionals. If your situation does not apply to the following categories, please contact your local Vanner Power Group Service Center or the Vanner Power Group Customer Service Department: 1-800-AC-POWER (1-800-227-6937). Please have your model and serial number available when consulting customer service.

Preliminary Checks

1. Indicator Light status
2. Inverter ON/OFF Switch and Remote ON/OFF Switch positions
3. AC Output Breakers CB-1, CB-2
4. Check all GFCI receptacles and circuit breakers as equipped throughout AC system
5. Battery voltage at battery and battery voltage at the inverter. Voltage present at inverter does not prove that all connections are sound especially under no AC load. (see item 7)
6. DC Fuse condition
7. Battery connections for tightness or corrosion
8. Try operating an AC load from the GFCI receptacle located on inverter front panel

Problem Symptoms and Troubleshooting Checks

Problem: Inverter Indicator Light does not turn ON.

Check: Verify DC voltage at the inverter.

Problem: Inverter Indicator Light is ON but the AC load will not operate.

Check: Check and reset GFCI receptacle or circuit breakers. Verify AC wiring. Try a different load such as a trouble light.

Problem: Low Battery Indicator Light is ON when AC load is applied.

Check: Check battery connections and condition. Recharge battery if voltage is less than 10.5 (21.0) VDC.

Problem: Over Temperature Indicator Light is ON.

Check: Verify fan operation. Remove obstructions from air exhaust vents and cooling fan.

- Problem:** Overload Indicator Light is ON when AC load is applied.
Check: Verify AC load is within the inverter's rated capacity. Remove excessive loads.
- Problem:** DC fuse blows when connecting DC input cables.
Check: Check for reverse polarity (Positive and negative DC cables reversed.)
- Problem:** Excessive audible buzzing during inverter operation but inverter operates loads.
Check: Check mounting bracket bolt tightness.
- Problem:** AC loads do not seem to be fully energized when operating from inverter power.
Check: Check AC output voltage at convenience receptacle. Check for overheated DC or AC wiring. Verify AC load specifications are not exceeded.
- Problem:** Unit does not operate and a "burnt wire" smell emits from inverter.
Check: Disconnect AC loads and battery immediately. Unit may require service, contact Vanner service department.

7 APPENDIX

Warranty

NORTH AMERICAN LIMITED WARRANTY

Vanner Inc., doing business as The Vanner Power Group, referred to herein as Vanner, warrants that this product is free from defects in materials and workmanship for a period of two (2) years from date of installation or two and one half (2 1/2) years from date of manufacture, whichever is less if and only if the following requirements are complied with:

1. The product is installed and checked out properly according to all guidelines, instructions, and checkout procedures set forth in the product Installation and Operating Manual.
2. The installer records all checkout data required and completes, signs, and returns the warranty registration card to Vanner within ten (10) days after installation.
3. The product was purchased after January 1, 2000.

Vanner does not warrant its products against any and all defects when: defect is a result of material or workmanship not provided by Vanner; normal wear and tear, or defects caused by misuse or use in contrary to instructions supplied, neglect, accident, reversed polarity, unauthorized repairs and/or replacements.

All warranties of merchantability and fitness for a particular purpose: written or oral, expressed or implied, shall extend only for a period of two (2) years from date of installation or two and one half (2 1/2) years from date of manufacture, whichever is first. There are no other warranties that extend beyond those described on the face of this warranty. Some states do not allow limitation on how long an implied warranty lasts, so the above limitations may not apply to you.

Vanner does not undertake responsibility to any purchaser of its product for any undertaking, representation, or warranty made by any dealers or distributors selling its products beyond those herein expressed unless expressed in writing by an officer of Vanner.

Vanner does not assume responsibility for incidental or consequential damages, including, but not limited to, responsibility for loss of use of this product, removal or replacement labor, loss of time, inconvenience, expense for telephone calls, shipping expense, loss or damage to property, or loss of revenue. Some states do not allow the exclusion or limitation of incidental or consequential damages, so these limitations may not apply to you.

Vanner reserves the right to repair, replace, or allow credit for any material returned under this warranty. Any damage caused by the customer will be charged or deducted from the allowance.

All warranty work will be performed at Vanner's factory, or authorized repair facility utilizing a valid Warranty Authorization Number (WAN) prior to repair. Products shall be delivered to Vanner's facility, freight prepaid and fully insured. Products repaired under warranty, or replacement parts or products will be returned to North American location prepaid via same transportation means and level of service as received, unless directed otherwise. Prepaid freight policy does not apply to locations outside North America.

GFCI Test Record

For maximum protection against electrical shock hazard, operate the Test Switch on the Ground Fault Circuit Interrupter at least once a month and record the values in this supplied table.

Figure 12 GFCI Test Record

YEAR	JAN	FEB	MAR	APR	MAY	JUN	JUL	AUG	SEP	OCT	NOV	DEC
20__												

**Vanner Power Group
4282 Reynolds Drive
Hilliard, Ohio 43026**

**1-800-AC POWER
(1-800-227-6937)
Tel: 614-771-2718
Fax: 614-771-4904**

**www.vanner.com
e-mail: pwrsales@vanner.com**

**Manual Part Number D98494
Printed in USA**