

Military 81-Series

Power Management System

With CAN Capable Smart Monitor™

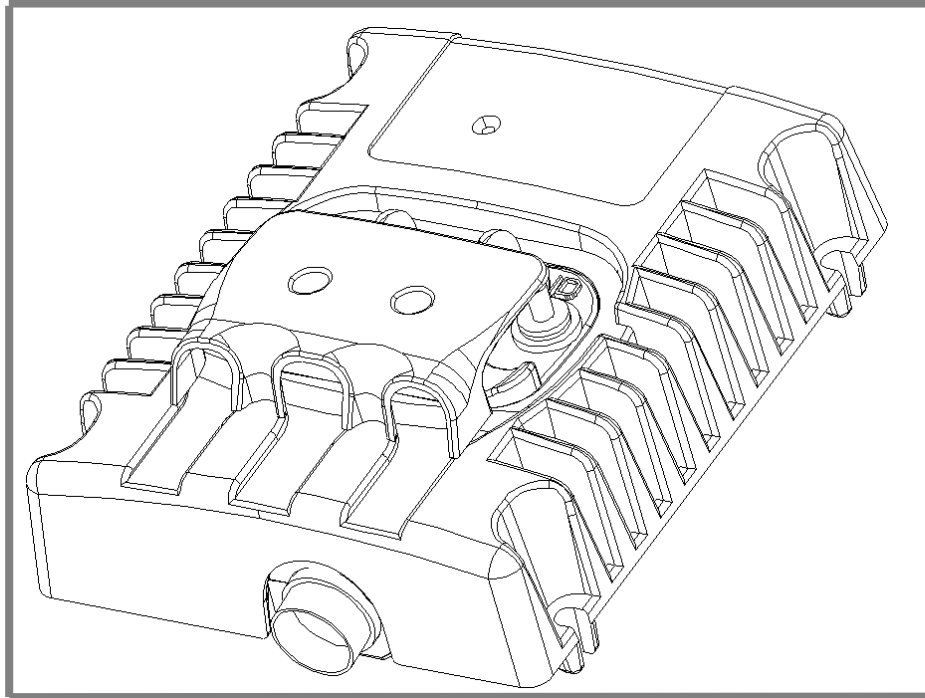

Table of Contents

Introduction.....	3
Specifications.....	4
Theory of Operation.....	5
Typical Applications.....	8
Installation Instructions.....	10
Testing and Troubleshooting.....	13
CAN Bus Interface.....	16

Notes

Introduction

Thank you for purchasing a Vanner *VANN-Guard CAN Power Management System*. We are confident that you will be very pleased with its performance because our 81-Series are designed and manufactured by skilled professionals using the highest standards in workmanship. With minimum maintenance and care, you can be assured of many years of trouble free service.

General Description

The Vanner *VANN-Guard CAN Power Management System* is an efficient and highly reliable method of obtaining a 12 volt DC power source from a 24 volt DC electrical system. The *VANN-Guard* makes the batteries look like they are in series and parallel at the same time. In addition to providing regulated 12 volt power, the system ensures that battery voltages remain equal which significantly extends battery life. Ideally suited for vehicle and alternate energy applications, the *VANN-Guard* is designed to save your batteries and the money you would spend replacing them. Users of the Vanner *VANN-Guard* know that it is the most cost effective and dependable solution for dual voltage systems.

The CAN (Controller Area Network) Capable Smart Monitor is a device designed to monitor and report the status of several critical functions in the vehicle electrical system. This unit provides real-time fault signals over the CAN bus to the vehicle electrical system controller. Fault indications can then be given from the vehicle's electrical system controller. Battery-monitoring algorithms have been incorporated into the 81-Series *VANN-Guard*, transmitting real time battery state of charge, state of health, and run time messages over CAN.

A typical system would include a 24VDC power source, such as an alternator or solar array, two 12 volt battery banks in series, and the *VANN-Guard*. The *VANN-Guard* connects to the 24 volt, 12 volt and ground terminals of the battery system. When the 12 volt loads require power, the *VANN-Guard* ensures that the current is taken equally from both batteries, and that the voltages of the two batteries are kept equal. This equalization ensures extended battery life and provides a stable 12 volt supply for operating accessories.

Paralleling VANN-Guard: Models are available which provide 60, 80 and 100 amps of 12 volt DC power. *VANN-Guard* may also be operated in parallel to provide more power. For example, two 60 amp units can be installed to provide 120 amps of 12 volt DC power.

NOTE: The Vanner *VANN-Guard CAN Power Management System* is an extremely reliable device and, when installed according to the instructions, will provide reliable operation for an indefinite period of time. However, if a system abnormality should develop that would cause a *VANN-Guard* malfunction, damage to the battery system could result if 12 volt loads are present.

Specifications

81-Series CAN Equalizers			
Model Number	81-60CAN	81-80CAN	81-100CAN
Input Voltage 24v	18 to 32 v		
Efficiency (Peak)	>96%	>96%	>96%
Max 24v Input Amps	32	43	53
Output Voltage	(Input Voltage/2) ±2%		
Output Amps (12v)	0-60	0-80	0-100
Standby Current	20 milliamps nominal at 28.4V		
Smart Monitor	Alarm Low/High Voltage, Imbalance, Under Voltage protect override, Vann-Guard fault Battery Monitoring		
Operating Temp.	-40°C to +95°C (-40°F to 203°F)		
Storage Temp.	-54°C to +105°C (-65°F to 221°F)		
Serviceable	No	No	No
Mounting Location	Mount on a flat surface close to the batteries to allow short cable runs. Location should be protected from battery acid and gases.		
Weights	11.7 lbs.	11.7 lbs.	11.7 lbs.
Electrical and Environmental Specifications			
Standoff Voltage	32Vdc		
Reverse Polarity	30V		
Heat Sink Temp	90°C		
Input Under Voltage Hysteresis	150mV each battery		
Input Over Voltage Turn Off	43Vdc		
Over-Temp Limit	100°C		
Over Temp Hysteresis	± 5°C		
Load Dump	SAE J1113/11 OCT1997		
ESD – Handling	±15kV	SAE J1113/13 OCT1997	
ESD – In Vehicle	±8kV Direct, ±15kV Air		SAE J1113/13 OCT1997 Class C
EMI Immunity	EN61000-4-6		
EMI Emissions	EN55022 Class B		
Thermal Shock	SAE J1455 JUN2006 Section 4.1.3.2		
Thermal Cycle	SAE J1455 JUN2006 Section 4.1.3.1		
Humidity	SAE J1455 JUN2006 Section 4.2		
Chemical Splash	SAE J1455 JUN2006 Section 4.4		
Pressure Wash	SAE J1455 JUN2006 - Section 4.5		
Immersion	IPX8	ANSI/IEC 60529-2004	
Dust Bombardment	IP6X	ANSI/IEC 60529-2004	
Salt Spray	96hrs	SAE J1455 JUN2006 Section 4.3	
Mechanical Vibration	SAE J1455 JUN2006 Section 4.10		
Handling Shock	SAE J1455 JUN2006 Section 4.11.3.1		

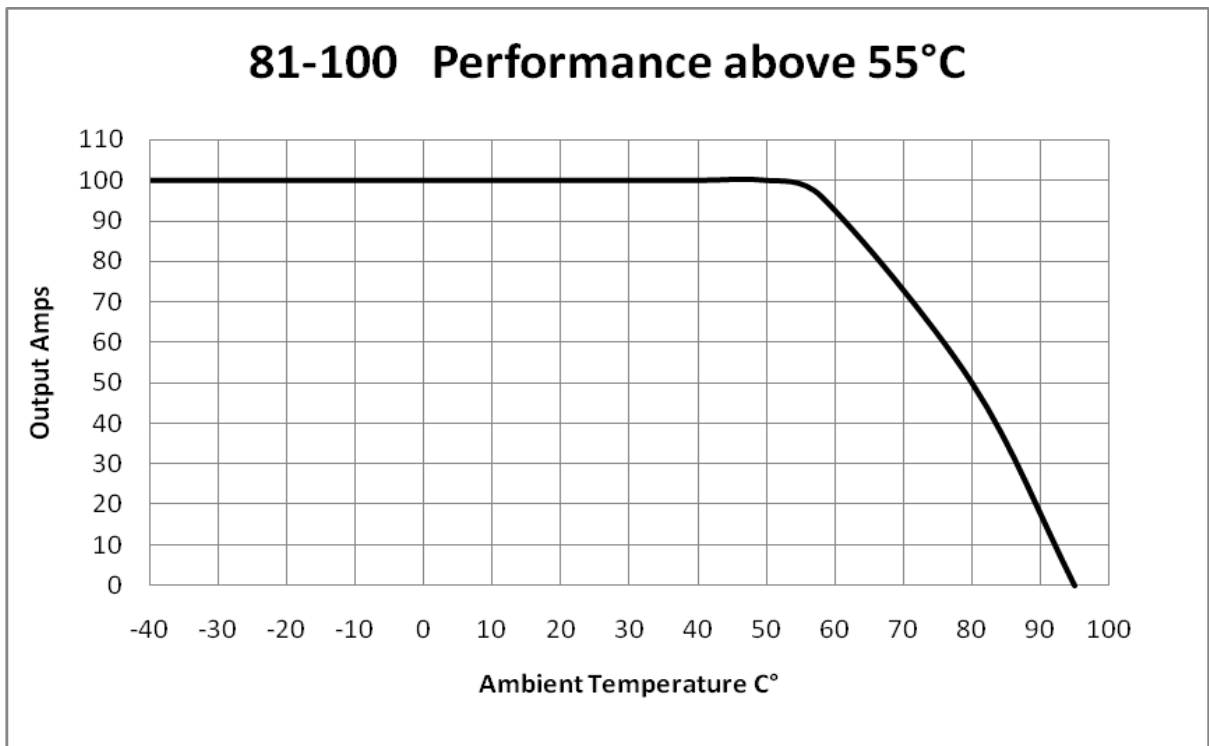
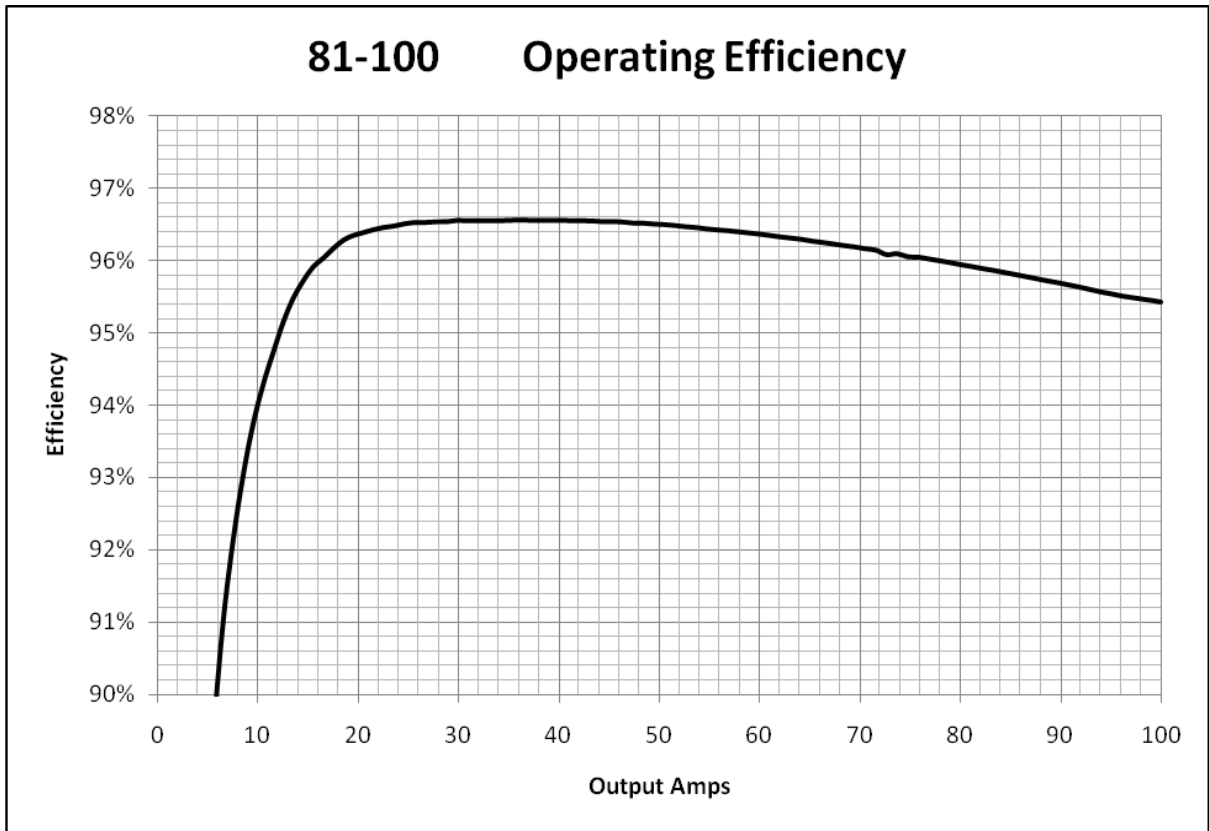

81-Series CAN Dimensional Specifications

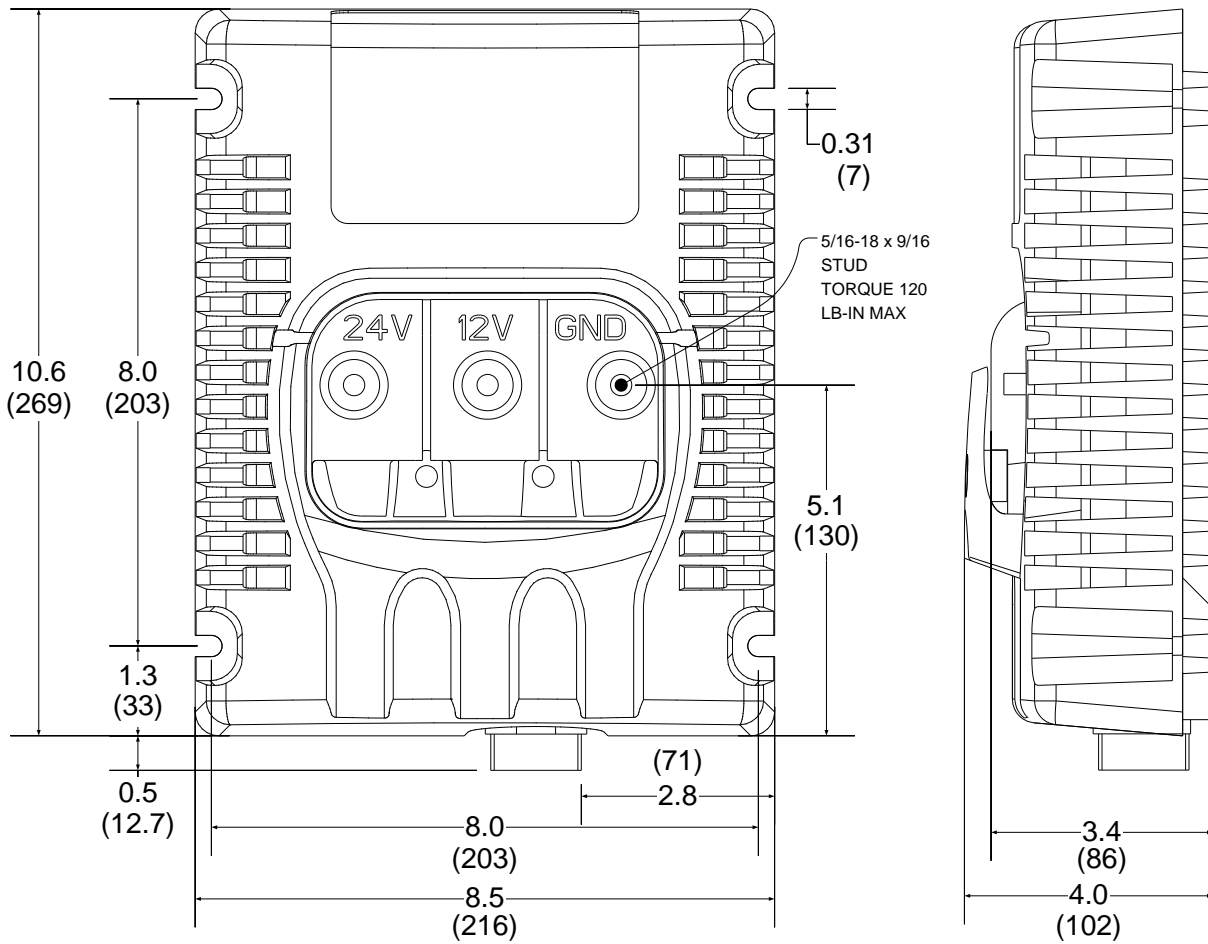

Theory of Operation

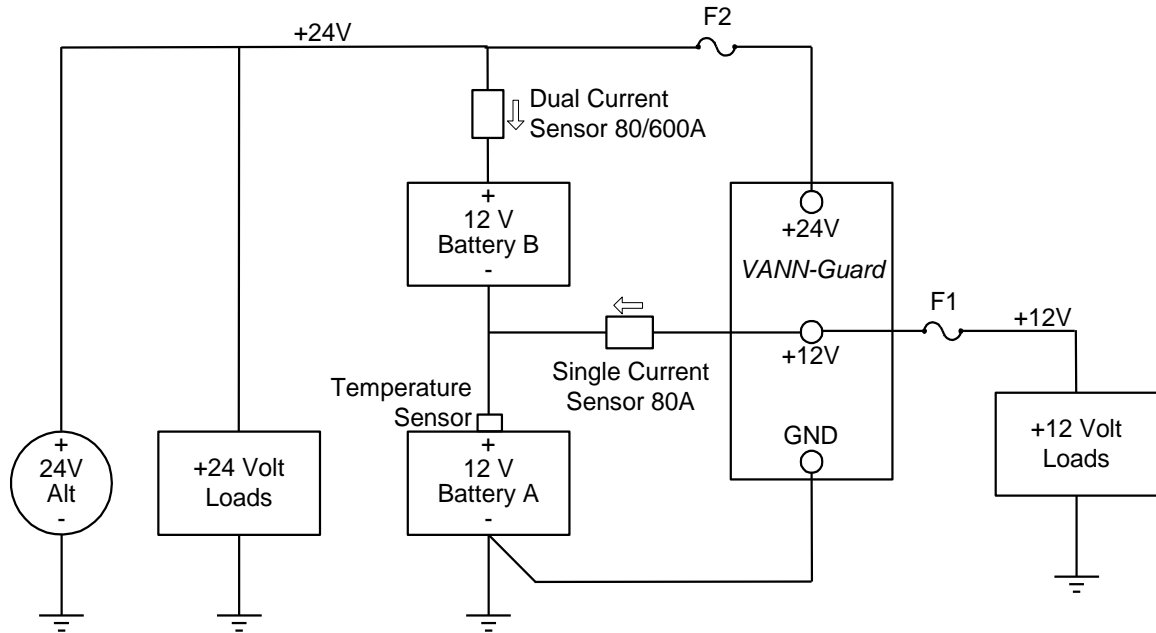

In many 24 volt electrical systems it is desirable to tap into the battery system to obtain power for 12 volt loads. This method, while seemingly simple, causes a charge imbalance resulting in Battery B (see diagram) being overcharged, and possibly boiling, while Battery A discharges.

To solve this application problem the Vanner *VANN-Guard* is connected to the battery system at the +24 volt, +12 volt, and ground points. The *VANN-Guard* makes the batteries look like they are in series and in parallel at the same time. The *VANN-Guard* maintains the voltage balance and therefore the charge acceptance rate of each battery. The *VANN-Guard* holds the Battery A and B voltages to within 0.05 volts under light loads and to within 0.1 volts at full rated load.

When the voltage of Battery A is higher than or equal to Battery B the *VANN-Guard* is in the standby mode, i.e., it is not transferring power from its 24 volt input to its 12 volt output. When a 12 volt load is present, and Battery A's voltage decreases to just below the voltage of Battery B, the *VANN-Guard* activates and transfers sufficient current from Battery B to Battery A to satisfy the load and maintain an equal voltage and charge in both batteries.

A key advantage of a system containing a Vanner *VANN-Guard*, compared to a DC to DC converter, is that if the 12 volt load requires a momentary surge current which exceeds the rated capacity of the *VANN-Guard*, Battery A will supply the extra current to the load. The *VANN-Guard* will then replenish the energy to Battery A after the surge has passed.

The following scenarios describe the *VANN-Guard CAN Power Management System* operation.

Scenario #1 - 24 volt load present, no 12 volt load present. The system operates as a system would without the *VANN-Guard* whether the alternator is ON or OFF. The *VANN-Guard* is in the standby mode except for making small adjustments to keep the batteries in balance.

Scenario #2 - Both 24 volt and 12 volt loads present, alternator is OFF. The *VANN-Guard* will insure that both batteries will discharge at the same rate even if different loads are present.

Scenario #3 - Both 24 volt and 12 volt loads present, alternator is ON. The alternator provides 24 volt power to the battery system and to the 24 volt loads. The *VANN-Guard* transfers power from the 24 volt source to the 12 volt load by converting 24 volt power to 12 volts. It will supply sufficient 12 volt power to satisfy the 12 volt load and to maintain battery voltage balance.

Smart Monitor functionality

All functionality described in this section requires that the Monitor Ignition Input (Terminal B) be connected to +24v in order to be active. Please see the above figure for placement of the current and temperature sensors.

A. Switched Sensor Supply Output

This output is used to provide +12v for the Vanner Smart Sensor™ and current sensors. The +12v output is switched for low power shutdown and sleep mode operation.

B. Smart Monitor Ignition (Enable) Input

This input powers the equalizer monitor. When this pin is taken to +24V the monitor becomes active.

C. CAN Shield

This connection is used to make common the shield on the CAN cable. This is required for noise considerations in vehicle electrical systems.

D. CAN Low

This is the connection for the vehicle's public CAN bus. The Smart Monitor will communicate faults to the vehicle's electrical system controller via the CAN bus.

E. CAN High

This is the connection for the vehicle's public CAN bus. The Smart Monitor will communicate faults to the vehicle's electrical system controller via the CAN bus.

F. Not Connected

This pin is not currently used.

G. Dual Current Sensor, High Range Output (+24V)

The monitor can record high amperage cranking current (up to 600A) on the +24V battery bank. The high current output of the dual current sensor should be connected to this input.

H. Sensor Ground

Connect ground for current sensors and Smart Sensors here.

J. Dual Current Sensor, Low Range Output (+24V)

The monitor can record the low amperage incoming and outgoing battery current on the +24V battery bank. The low range output of the dual current sensor should be connected to this input.

K. Single Current Sensor (+12V) Signal Input

The monitor can record incoming and outgoing battery current on the lower battery. The output from the current sensor monitoring the +12v output line should be connected to this input.

L. Temperature Sensor

The monitor can record the temperate of the batteries. The output from the temperature sensor should be connected to this input.

M. +24V Battery Remote Sense

If this pin is connected directly to the +24V battery positive by a separate line, it will improve the accuracy of the Equalizer balance of the batteries when load current is drawn. See below for more information.

N. +12V Battery Remote Sense

If this pin is connected directly to the +12V battery positive by a separate line, it will improve the accuracy of the Equalizer balance of the batteries when load current is drawn. See below for more information.

P. Battery Ground Remote Sense

If this pin is connected directly to the battery ground by a separate line, it will improve the accuracy of the Equalizer balance of the batteries when load current is drawn. See below for more information.

Deutsch Connector Pin Out

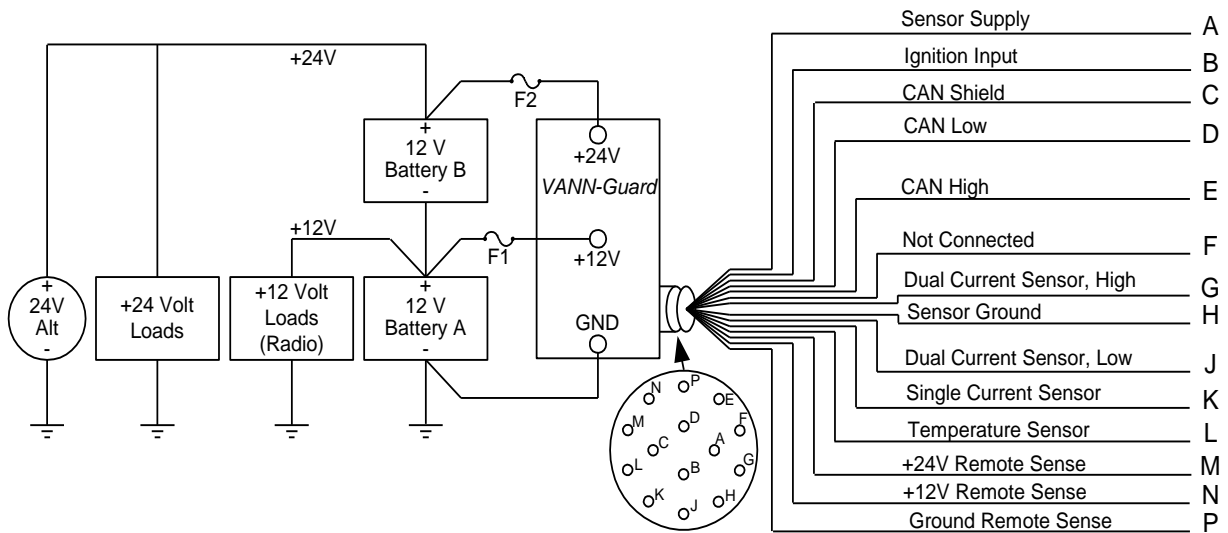

The monitor output from the unit is a through a Deutsch brand connector P/N: HDP20-18-14PN. The mating connector is the Deutsch P/N: HDP26-18-14SN housing with Deutsch P/N: 1062-16-0622 socket contact.

Remote Sense (Terminals M, N, and P)

There are three inputs for this function, +24, +12, and ground. They are for remote sense of the battery voltage. This makes the Equalize function insensitive to wire, fuse and connection voltage drops. All three sense lines must be connected for this function to work properly. It is usual for the battery connections to be brought to a distribution point from where connections are made to the rest of the vehicle. Since the battery charge current is the only current which the battery cables carry for most of the time it is convenient to connect the sense wires to these distribution points. This should not introduce a significant error. In fact, when the system stabilizes and the batteries are charged there will be almost no error.

The sense wires can be 16 or 18AWG as the input impedance is high, and the wire gauge can be set for mechanical strength requirements. This allows cost savings and freedom of configuration in the Equalizer power connection wiring, and more freedom in Equalizer location. The equalizer current carrying wire gauge can be the minimum size listed in this manual's wire size table for a given Equalizer rating, up to four times the distance listed. This sets a maximum voltage drop of 0.4V which is reasonable from efficiency and fault detection considerations.

Installation Instructions

These symbols are used to note procedures that if not closely followed could lead to loss of life or damage to equipment or property due to electrocution.



Electrocution hazard exists



Fire hazard exists



A potentially dangerous condition



Explosive hazard exists



Corrosive hazard exists



Do not exceed the specified torque of 120 in-lbs. when connecting cables to the terminal posts (+24, GND, +12) during installation of all the VANN-Guard Models. Torque values higher than specified may damage the product, reduce performance, and/or create hazardous conditions. Products damaged by improper torque are not covered by the warranty.



Do not connect more than one conductor per terminal post on any Vanner VANN-Guard. Multiple wires and cables may overstress internal components, resulting in poor performance or creating hazardous conditions. Products damaged by the installation of multiple conductors per post are not covered by the warranty.



Fault protection devices must be installed between the VANN-Guard and the power source (battery). A fault protection device would be any fuse or circuit breaker properly rated for the maximum DC current obtainable. This advisory is in accordance with SAE, NEC and UL, for mobile power applications. Install per applicable codes or within 18" of the battery. See Wire and Fuse Sizing Chart on page 13 of this manual or contact Vanner at 1-800-227-6937 or pwrsales@vanner.com if assistance is needed in sizing fault protection devices.



Caution: This equipment tends to produce arcs and sparks during installation. To prevent fire or explosion, compartments containing batteries or flammable materials must be properly ventilated. Safety goggles should always be worn when working near batteries



Mounting Location –The *VANN-Guard* may be mounted in any orientation, on a flat mounting surface suitable to support the *VANN-Guard* during application. Do not mount in zero-clearance compartment that may result in the *VANN-Guard* overheating. Locate so that contact by people is unlikely.

Environmental Protection – Your *VANN-Guard* has been designed to withstand direct exposure to rain and moisture. The *VANN-Guard* has also been tested for exposure to direct pressure spray, but continual exposure to direct pressure spraying may reduce the *VANN-Guard* serviceable life. Any damage due to water contamination is covered by Vanner only through the terms of our factory warranty.

Wiring Sequence– The *VANN-Guard* is internally protected for reverse polarity. The wiring sequence is not an issue with the *VANN-Guard* products.

Strain Relief – The *VANN-Guard* has an integral strain relief. The *VANN-Guard* is designed with wells for the lug to sit into to resist bolt loosening from cable movement, and the strain relief is designed to further inhibit cable movement. The diagram below shows the proper orientation for the attachment of the strain relief and the #10-32 mounting hardware that is supplied.

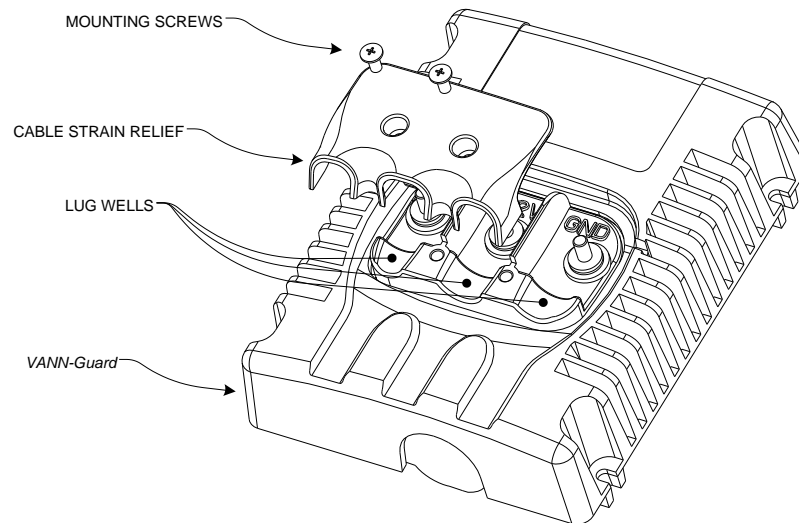

⚠ ⚡ Caution adding 12volt batteries

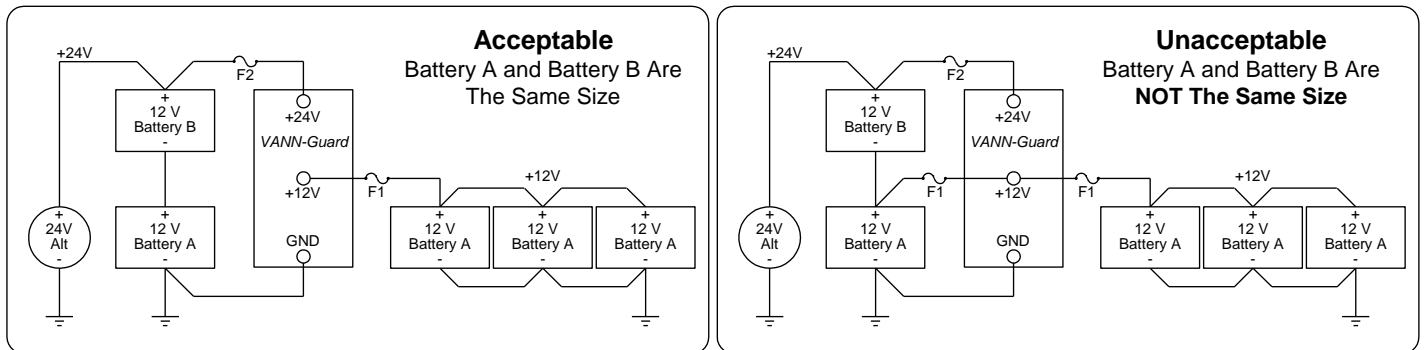

In certain applications, such as private coach or alternate energy applications, it may be desirable to have additional 12 volt “House Batteries” to operate heavy 12 volt (inverter) loads. Use the *VANN-Guard* to charge the additional batteries.

Connect the *VANN-Guard* 12V terminal to the additional batteries only. Do not connect the *VANN-Guard* 12V terminal to both battery banks as this would make Battery A larger than Battery B. **Damage to Battery B may occur during charging** due to overcharging, if the *VANN-Guard* cannot keep up with the charging system.

⚠ ⚡ Caution using a Ground-Side Battery Disconnect Switch

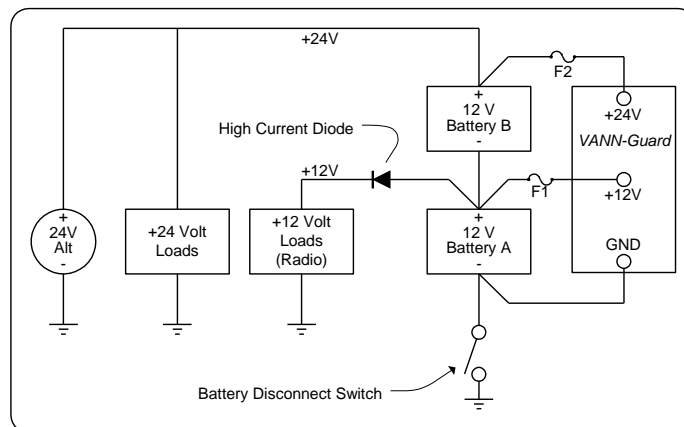

The system must be wired as shown to prevent Reverse Polarity Damage to polarity sensitive 12 volt loads while the ground-side disconnect switch is open. The *VANN-Guard's* GND terminal must be wired to the battery side of the ground-side disconnect switch circuit for the *VANN-Guard* to work properly.

Install the external High Current Diode, such as Vanner Model 52-75 (45 amp continuous rating) to protect polarity sensitive 12 volt loads if these loads do not already contain input diode protection. This prevents a reverse polarity on the 12 volt equipment when the battery switch is open. The reverse polarity does not come from the *VANN-Guard*, but from any 24 volt equipment that may be turned ON.

Wire Size and temperature rating

Cables connecting the *VANN-Guard* to the batteries must be sufficiently sized to prevent unwanted voltage drops. These voltage drops (loss) must be less than 0.05 VDC between the *VANN-Guard's* +24 volt terminal and the battery +24 volt terminal (Battery B positive terminal), less than 0.10 VDC between the *VANN-Guard's* +12 volt terminal and the battery +12 volt terminal (the jumper between Battery A and Battery B), and less than 0.05 VDC between the *VANN-Guard's* GND terminal and the battery ground terminal (Battery A negative terminal that is connected to chassis ground). In most installations, the *VANN-Guard's* terminals are wired directly to the battery terminals (reference fault protection) to prevent voltage loss that could occur in switch contacts, connections, and long wire runs. Since the *VANN-Guard* can be operated in temperatures up to 75°C, use wire rated at least 90°C. See Wire and Fuse Size Chart.

Wire and Fuse Size Chart

Wire Size AWG	Ring Terminal AMP or UL recognized equal	Max wire length, in feet, between <i>VANN-Guard</i> and battery to keep voltage drop under 0.1 volt. The chart assumes wire carries no other load and wire temperature is below 80°C.			
		81-60CAN	81-80CAN	81-100CAN	2 X 81-100CAN
#8	33462	2.1	XXX	XXX	XXX
#6	33466	3.2	2.4	XXX	XXX
#4	33470	5.9	4.4	3.5	XXX
#2	322870	8.7	6.5	5.2	2.6
#1	321867	10.9	8.2	6.5	3.3
#1/0	321867	13.8	10.4	8.3	4.1
#2/0	321870	17.6	13.2	10.5	5.3
Fuse F1		80 amp	100 amp	125 amp	250 amp
Fuse F2		40 amp	50 amp	80 amp	150 amp

Crimp the ring terminals using **AMP** ROTA-CRIMP 600850 (2/0 - 8ga).

AMP Product Information Center: 800-522-6752

AMP Tooling Assistance Center: 800-722-1111

Note: The wire gages listed are for use without remote sense; see the monitor section for applications using the remote sense capability.

Testing and Troubleshooting



Servicing of electrical systems should only be performed by trained and qualified technical personnel.

Equipment Required

VoltMeter having 0.01 volt resolution. (Fluke Model 87 Multimeter recommended).
Clamp-on current meter (Fluke Model 36 Clamp-on Meter recommended).

Vanner Repair Service

Vanner offers a quick turn around factory repair service. Send the unit to the address below with a note instructing us to repair it. Include your name, phone number, shipping address (not a P.O. Box Number), and your purchase order number.

Test Procedure for *VANN-Guard* 81-Series CAN Power Management Systems

The *VANN-Guard* is working properly if:

1. The 12 volt DC loads are being operated continuously and are within the rated capacity of the *VANN-Guard* and;
2. Battery A voltage is lower than Battery B by no more than 0.05 to 0.10 volts (measured at the *VANN-Guard*'s +24, +12 and GND terminals).

Vanner *VANN-Guards* are electronically protected against reverse polarity damage therefore the DC connection sequence is not an issue.

Vanner *VANN-Guards* will not function properly unless all three battery connections are made. Battery A and Battery B voltages both must be above 8 volts for the unit to turn ON.

Vanner *VANN-Guards* may be used in parallel with other *VANN-Guards* and Vanner Equalizer models.

Please note that the 24V, 12V and GND stud position and orientation are different on *VANN-Guard* 81-Series than on other Vanner Equalizers.

VANN-Guard Test Procedure:

1. Field-test the equalizer while fully connected to the vehicle batteries. For bench testing, two 12 volt batteries, or two 12 volt power supplies are required. The *VANN-Guard* must be connected to the batteries at GND, 12V and 24V to function properly.
2. If battery voltage is below 24 volts start the vehicle or apply a 24 volt battery charger to the batteries.
3. Turn ON 12 volt DC loads up to the *VANN-Guard*'s rated capacity. Measure DC current on the *VANN-Guard* +12V cable to verify load current.
4. **At the *VANN-Guard*** measure and record:
 - a. Battery A voltage (voltage between the *VANN-Guard*'s +12 and GND terminals)
 - b. Battery B voltage (voltage between the *VANN-Guard*'s +24 and +12 terminals)
5. Subtract Battery A voltage from Battery B voltage and compare readings.

Voltage Comparison		VANN-Guard Status	
a.	Battery A is lower than Battery B but within 0.05 volt.	OFF	Stand-by Mode. The VANN-Guard will not turn ON until Battery A is lower than Battery B by more than 0.05 volts.
b.	Battery A is lower than Battery B by 0.05 to 0.10 volts.	ON	Normal Operating Mode
c.	Battery A is lower than Battery B by more than 0.10 volts	ON	Self-Protection Mode due to Overload Condition. See below.
d.	Battery A is lower than Battery B by more than 0.10 volts	OFF	The VANN-Guard is not functioning properly.
e.	Battery A is <u>higher</u> than Battery B	Abnormal condition. Suspect Battery B is defective or a 12 volt load is connected to Battery B.	

Overload Condition

An overload condition exists when the 12 volt loads exceed the VANN-Guard's rated capacity. The overload condition will not damage the VANN-Guard, but may cause damage to the batteries.

During the overload, the VANN-Guard's output is limited by internal protection circuits to its Rated Output Amps. The 12 volt amps exceeding the VANN-Guard's output are drawn from Battery A which will begin to draw the batteries out of balance. The VANN-Guard's full Rated Output Amps are maintained as long as Battery A and Battery B remain balanced within 0.10 volt. The internal protection circuits will reduce the VANN-Guard's output as the batteries become further out-of-balance. If Battery A voltage falls below approximately 8 volts the VANN-Guard will shut itself OFF.

To correct the overload condition the 12 volt load must be reduced or the VANN-Guard's rated capacity must be increased.

Trouble Shooting an Engine No-Start Situation

Situation:

A coach has dead batteries and won't start while jump starting. The coach is equipped with a 24 volt starting and charging system, a 12 volt electronic diesel engine control, a VANN-Guard, and a moderate 12 volt load which cannot be turned OFF. The coach sits for several days and the batteries run completely dead. During jump-starting the engine cranks but does not start due to low voltage on the 12 volt supply. Electrical testing reveals there is no 12 volt output from the VANN-Guard while jump starting even though the VANN-Guard separately tests OK.

Cause:

The 12 volt load which could not be turned OFF first ran both batteries down until the VANN-Guard shut itself OFF due to low voltage. (The VANN-Guard will shut OFF if system voltage falls below 16 volts or if voltage on either battery falls below 8 volts.) Then Battery A alone was drained to near zero volts. As the bus is being jumped, 12 volt loads hold Battery A voltage too low for the VANN-Guard to turn ON and Battery A is too weak to support the 12 volt electronic engine control.

Solution:

Turn OFF all 12 volt loads (turning the battery disconnect switch OFF may accomplish this). Connect the jumper cables but do not crank the engine for two or three minutes. (Both batteries must rise above 8 volts.) The battery disconnect switch can then be turned ON and the bus should have adequate 12 volt power to start.

The CAN Bus Interface PGN Description

The 81 series equalizer CAN bus interface allows for reception of messages for control of the equalizer and transmission of messages that reflect equalizer status, as well as gathering data from external devices. The CAN protocol used for the equalizer is SAE J1939. The Parameter Group Numbers (PGNs) assigned to the equalizer are proprietary and are in PDU2 Format. Currently, there are two Parameter Group Numbers (PGNs) assigned that provide for CAN control from the equalizer and four that provide for CAN status. Both the control and status messages use priority 6. Additional PGNs have been identified for future expansion.

The data format within the J1939 CAN data frames adhere to the following convention: each CAN message consists of 8 bytes (defined 1-8) of data, and each byte is defined as bits 0-7. Values are normally given in decimal, but may also be indicated in hexadecimal or binary. A 0x preceding the number indicates a hexadecimal value, and a 0b preceding indicates a binary value

PGN criteria for the messages in this document is as follows:

- PGN range: 65490 (0xFFD2) to 65499 (0xFFDB)
- Source address of messages from the equalizer: 30 (0x1E)
- Commands to the equalizer: 65490 (0xFFD2), 65491 (0xFFD3)
- Source address of messages to the equalizer: Any
- Data from the equalizer: 65492 (0xFFD4) to 65499 (0xFFDB)

A list of PGNs used by equalizer is shown in Table 1.:

Table 1 - CAN BUS Parameter Group Definitions

PGN		Description	Source Address		Priority	Message ID (Hex)	Transmit Interval
Decimal	Hex		Decimal	Hex			
65490	0xFFD2	Control Message	Any	Any	6	0xFFD2xx ¹	1 second
65491	0xFFD3	Set Equalizer Parameters	Any	Any	6	0xFFD3xx ¹	1 second
65492	0xFFD4	Equalizer Status	30	0x1E	6	0xFFD41E	3 second
65493	0xFFD5	Heartbeat	30	0x1E	6	0xFFD51E	3 second
65494	0xFFD6	Voltages and Currents	30	0x1E	6	0xFFD61E	3 seconds
65497	0xFFD9	Battery States	30	0x1E	6	0xFFD91E	5 seconds or as needed
65499	0xFFDB	Reserved for Future Expansion					
65526	0xFECA	DM1 Message	30	0x1E	6	0xFECA1E	1 second or as needed
60416	0xEC00	BAM Connection Management Message	30	0x1E	6	0xECFF1E	As required by multi-packet DM1 messages
60160	0xEB00	BAM Transfer Protocol Message	30	0x1E	6	0xEBFF1E	As required by multi-packet DM1 messages
65259	0xFEEB	Component Identification	30	0x1E	6	0xFEEB1E	User Defined
65242	0xFEDA	Software Identification	30	0x1E	6	0xFEDA1E	User Defined
59904	0xEA00	Request	Any	Any	6	0xEA1Esa ²	User Defined

1- xx indicates that the Source Address is don't care and should be ignored. Since there may be multiple controllers in a system, the equalizer will respond to messages from any Source Address.

2 - For the Request PGN, the PDU Specific is the Destination Address, which is the equalizer. SA indicates the Source Address, which will typically be 216 (system controller) or 65 (Clever Devices AVM system)

PGN 65490 - Equalizer Control 1

Message: PGN 65490 (0xFFD2)
 Message Type: Broadcast
 Source Address: System controller, 216 (0xD8)
 Intended Recipient: Equalizer, 30 (0x1E)
 Priority: 6
 29 Bit identifier: 0x18FFD2xx
 Transmission repetition rate: As needed
 Data length: 8 bytes

- Byte 1:
- Bit 0,1 CAN_JSO – Commands the equalizer jump start override (JSO) state via the CAN Bus. Enable causes JSO to be on, and disable turns off JSO.
 - Bit 2,3 CAN_ONOFF_EN – Enables or disables the capability of the equalizer to be turned on and off using the CAN Bus command bits CAN_EQ_ONOFF. Disabled at power-up.
 - Bit 4,5 CAN_EQ_ONOFF – Command that turns the equalizer on (Enable, 0b01) or off (Disable, 0b00). A 0x11 will cause no action to be taken.
 - Bit 6,7 not used.

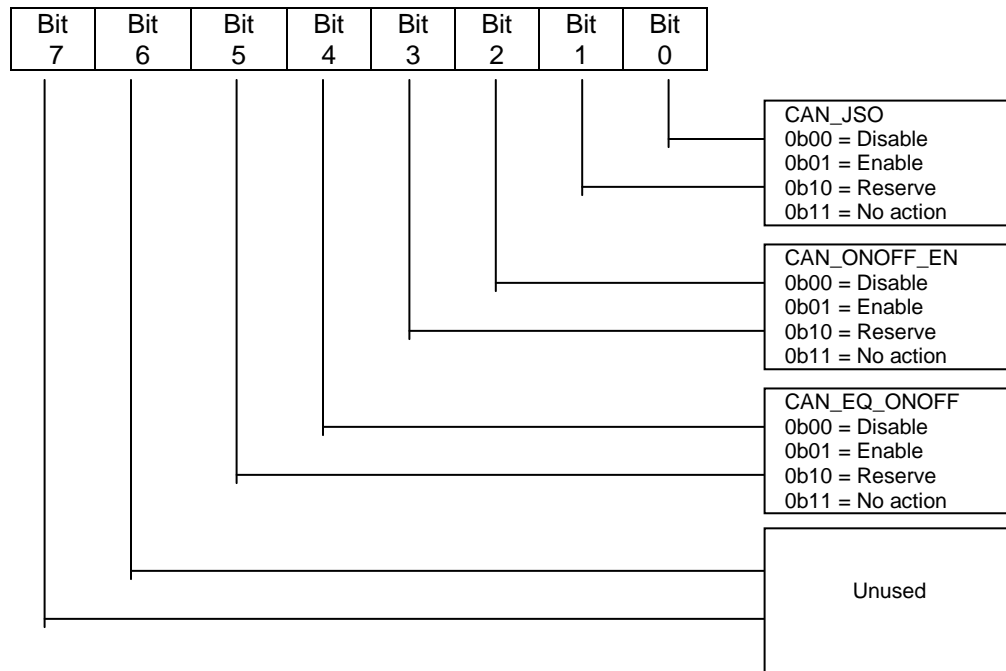

PGN 65491, Index Byte Value = 0 - Equalizer Factory Reset

Message:	PGN 65491 (0xFFD3)
Message Type:	Broadcast
Source Address:	System controller, 216 (0xD8)
Intended Recipient:	Equalizer, 30 (0x1E)
Priority:	6
29 Bit identifier:	0x18FFD3D8
Transmission repetition rate:	1 second
Data length:	8 bytes

For all values below, the data values between 65280-65535 (0xFF00-0xFFFF) indicate not requested. For those data values, the parameter on the equalizer will not change.

Index Byte

Byte 1: Must be 0 (0x00) for the Equalizer Factory Reset message.

Profile: The Number of Battery Profiles Saved in code

Byte 2,3:	16 bit unsigned integer, byte 3 most significant byte
Resolution:	1 /bit, no offset, no sign bit
Data Range:	0: system default 1: East Penn 8A31DT 2: UK test system - SVR80 3: Vanner test system - XE70 4: Deka 7T31 x 2

Bytes 4,5,6,7,8: Unused

PGN 65491, Index Byte Value = 1 - Equalizer Parameters 1

Message:	PGN 65491 (0xFFD3)
Message Type:	Broadcast
Source Address:	System controller, 216 (0xD8)
Intended Recipient:	Equalizer, 30 (0x1E)
Priority:	6
29 Bit identifier:	0x18FFD3D8
Transmission repetition rate:	1 second
Data length:	8 bytes

For all values below, the data values between 65280-65535 (0xFF00-0xFFFF indicate not requested. For those data values, the parameter on the equalizer will not change.

Index Byte

Byte 1: Must be 1 (0x01) for the Equalizer Parameters 1 message.

Nj: Number of Cells

Typical value is 6 for a 12 V battery, 12 for two 12 V batteries.

Byte 2,3:	16 bit unsigned integer, byte 3 most significant byte
Resolution:	1 cell/bit, no offset, no sign bit
Data Range:	0 to 64255

Ef: Battery Charge Efficiency

Bytes 4,5:	16 bit unsigned integer, byte 5 the most significant byte
Resolution:	0.1 %/bit gain, no offset, no sign bit
Data Range:	0 to 6425.5

C: Peukerts Aht Rating of Battery

Bytes 6,7:	16 bit unsigned integer, byte 7 the most significant byte
Resolution:	0.01 amp hours/bit gain, no offset, no sign bit
Data Range:	0 to 642.55

Byte 8: Unused

PGN 65491, Index Byte Value = 2 - Equalizer Parameters 2

Message:	PGN 65491 (0xFFD3)
Message Type:	Broadcast
Source Address:	System controller, 216 (0xD8)
Intended Recipient:	Equalizer, 30 (0x1E)
Priority:	6
29 Bit identifier:	0x18FFD3D8
Transmission repetition rate:	1 second
Data length:	8 bytes

For all values below, the data values between 65280-65535 (0xFF00-0xFFFF) indicate not requested. For those data values, the parameter on the equalizer will not change.

Index Byte

Byte 1: Must be 2 (0x02) for the Equalizer Parameters 2 message.

n: Peukerts Number

Bytes 2,3:	16 bit unsigned integer, byte 3 the most significant byte
Resolution:	0.001 units/bit gain, no offset, no sign bit
Data Range:	0 to 64.255

Tc: Temperature Constant

Typical value is 0.01

Bytes 6,5:	16 bit unsigned integer, byte 5 the most significant byte
Resolution:	0.001 units/bit gain, no offset, no sign bit
Data Range:	0 to 64.255

Tr: Rated Temperature

Bytes 6,7:	16 bit unsigned integer, byte 7 the most significant byte
Resolution:	0.01 °C /bit gain, no offset, no sign bit
Data Range:	0 to 642.55

Byte 8: Unused

PGN 65491, Index Byte Value = 3 - Equalizer Parameters 3

Message:	PGN 65491 (0xFFD3)
Message Type:	Broadcast
Source Address:	System controller, 216 (0xD8)
Intended Recipient:	Equalizer, 30 (0x1E)
Priority:	6
29 Bit identifier:	0x18FFD3D8
Transmission repetition rate:	1 second
Data length:	8 bytes

For all values below, the data values between 65280-65535 (0xFF00- 0xFFFF indicate not requested. For those data values, the parameter on the equalizer will not change.

Index Byte

Byte 1: Must be 3 (0x03) for the Equalizer Parameters 3 message.

Ve: Endpoint Voltage

Bytes 2,3: 16 bit unsigned integer, byte 3 the most significant byte
Resolution: 0.001 V/bit gain, no offset, no sign bit
Data Range: 0 to 64.255

thC: Charge Threshold

Typical value is 5.0

Bytes 4,5: 16 bit unsigned integer, byte 5 the most significant byte
Resolution: 0.01 A/bit gain, -327.68 offset
Data Range: -327.68 to 314.87

thD: Discharge Threshold

Typical value is -5.0

Bytes 6,7: 16 bit unsigned integer, byte 7 the most significant byte
Resolution: 0.01 A /bit gain, -327.68 offset
Data Range: -327.68 to 314.87

Byte 8: Unused

PGN 65491, Index Byte Value = 4 - Equalizer Parameters 4

Message:	PGN 65491 (0xFFD3)
Message Type:	Broadcast
Source Address:	System controller, 216 (0xD8)
Intended Recipient:	Equalizer, 30 (0x1E)
Priority:	6
29 Bit identifier:	0x18FFD3D8
Transmission repetition rate:	1 second
Data length:	8 bytes

For all values below, the data values between 65280-65535 (0xFF00- 0xFFFF indicate not requested. For those data values, the parameter on the equalizer will not change.

Index Byte

Byte 1: Must be 4 (0x04) for the Equalizer Parameters 4 message.

thBC: Boost Charge Threshold

Typical value is 50.0

Bytes 2,3:	16 bit unsigned integer, byte 3 the most significant byte
Resolution:	0.01 A/bit gain, -327.68 offset
Data Range:	-327.68 to 314.87

thS: Start Threshold

Typical value is 150.0

Bytes 4,5:	16 bit unsigned integer, byte 5 the most significant byte
Resolution:	0.1 A/bit gain, -3276.8 offset
Data Range:	-3276.8 to 3148.7

thCS: Cold Start Threshold

Typical value is 300.0

Bytes 6,7:	16 bit unsigned integer, byte 7 the most significant byte
Resolution:	0.1 A /bit gain, -3276.8 offset
Data Range:	-3276.8 to 3148.7

PGN 65491, Index Byte Value = 5 - Equalizer Parameters 5

Message:	PGN 65491 (0xFFD3)
Message Type:	Broadcast
Source Address:	System controller, 216 (0xD8)
Intended Recipient:	Equalizer, 30 (0x1E)
Priority:	6
29 Bit identifier:	0x18FFD3D8
Transmission repetition rate:	1 second
Data length:	8 bytes

For all values below, the data values between 65280-65535 (0xFF00-0xFFFF) indicate not requested. For those data values, the parameter on the equalizer will not change.

Index Byte

Byte 1: Must be 5 (0x05) for the Equalizer Parameters 5 message.

Ahr: Amper-hr Rating of Battery

Bytes 2,3:	16 bit unsigned integer, byte 3 the most significant byte
Resolution:	0.01 amp hours/bit gain, no offset, no sign bit
Data Range:	0 to 642.55

BCC: Battery Current Cranking

Typical value is 350.0

Bytes 4,5:	16 bit unsigned integer, byte 5 the most significant byte
Resolution:	0.1 A/bit gain, no offset, no sign bit
Data Range:	0 to 6425.5

BVMT: Battery Voltage Trip

Typical value is 1.25

Bytes 7,8:	16 bit unsigned integer, byte 7 the most significant byte
Resolution:	0.001 V/bit gain, no offset, no sign bit
Data Range:	0 to 64.255

PGN 65491, Index Byte Value = 6 - Equalizer Parameters 6

Message:	PGN 65491 (0xFFD3)
Message Type:	Broadcast
Source Address:	System controller, 216 (0xD8)
Intended Recipient:	Equalizer, 30 (0x1E)
Priority:	6
29 Bit identifier:	0x18FFD3D8
Transmission repetition rate:	1 second
Data length:	8 bytes

For all values below, the data values between 65280-65535 (0xFF00-0xFFFF) indicate not requested. For those data values, the parameter on the equalizer will not change.

Index Byte

Byte 1: Must be 6 (0x06) for the Equalizer Parameters 6 message.

Chr: C Rating of Ahr

Typical value is 10.0

Bytes 2,3:	16 bit unsigned integer, byte 3 the most significant byte
Resolution:	0.01 V/bit gain, no offset, no sign bit
Data Range:	0 to 642.55

BCLfsd: Current Low, Full Scale Deflection

Typical value is 80

Bytes 4,5:	16 bit unsigned integer, byte 5 the most significant byte
Resolution:	0.1 A/bit gain, no offset, no sign bit
Data Range:	0 to 6425.5

BCHfsd: Current Low, Full Scale Deflection

Typical value is 600.0

Bytes 6,7:	16 bit unsigned integer, byte 7 the most significant byte
Resolution:	0.1 V /bit gain, no offset, no sign bit
Data Range:	0 to 6425.5

PGN 65491, Index Byte Value = 7 - Equalizer Parameters 7

Message:	PGN 65491 (0xFFD3)
Message Type:	Broadcast
Source Address:	System controller, 216 (0xD8)
Intended Recipient:	Equalizer, 30 (0x1E)
Priority:	6
29 Bit identifier:	0x18FFD3D8
Transmission repetition rate:	1 second
Data length:	8 bytes

For all values below, the data values between 65280-65535 (0xFF00-0xFFFF) indicate not requested. For those data values, the parameter on the equalizer will not change.

Index Byte

Byte 1: Must be 7 (0x07) for the Equalizer Parameters 7 message.

SOC1: State of Charge - 12V Battery

Bytes 2,3: 16 bit unsigned integer, byte 3 is the most significant byte
Resolution: 1%/bit, no offset, no sign bit
Data Range: 0 to 100%

SOH1: State of Health - 12V Battery

Bytes 4,5: 16 bit unsigned integer, byte 5 is the most significant byte
Resolution: 1%/bit, no offset, no sign bit
Data Range: 0 to 100%

SOC2: State of Charge - 24V Battery

Bytes 6,7: 16 bit unsigned integer, byte 7 is the most significant byte
Resolution: 1%/bit, no offset, no sign bit
Data Range: 0 to 100%

PGN 65491, Index Byte Value = 8 - Equalizer Parameters 8

Message:	PGN 65491 (0xFFD3)
Message Type:	Broadcast
Source Address:	System controller, 216 (0xD8)
Intended Recipient:	Equalizer, 30 (0x1E)
Priority:	6
29 Bit identifier:	0x18FFD3D8
Transmission repetition rate:	1 second
Data length:	8 bytes

For all values below, the data values between 65280-65535 (0xFF00-0xFFFF) indicate not requested. For those data values, the parameter on the equalizer will not change.

Index Byte

Byte 1: Must be 8 (0x08) for the Equalizer Parameters 8 message.

SOH2: State of Health - 24V Battery

Bytes 2,3: 16 bit unsigned integer, byte 3 is the most significant byte
Resolution: 1%/bit, no offset, no sign bit
Data Range: 0 to 100%

PGN 65491, Index Byte Value = 9 - Equalizer Parameters 9

Message:	PGN 65491 (0xFFD3)
Message Type:	Broadcast
Source Address:	System controller, 216 (0xD8)
Intended Recipient:	Equalizer, 30 (0x1E)
Priority:	6
29 Bit identifier:	0x18FFD3D8
Transmission repetition rate:	1 second
Data length:	8 bytes

For all values below, the data values between 65280-65535 (0xFF00-0xFFFF) indicate not requested. For those data values, the parameter on the equalizer will not change.

Index Byte

Byte 1: Must be 9 (0x09) for the Equalizer Parameters 9 message.

OVSet: Over voltage setpoint

Bytes 2,3: 16 bit unsigned integer, byte 3 is the most significant byte
Resolution: 0.1V/bit, no offset, no sign bit
Data Range: 20.0 V to 40.0 V

UVSet: Under voltage setpoint

Bytes 4,5: 16 bit unsigned integer, byte 5 is the most significant byte
Resolution: 0.1V/bit, no offset, no sign bit
Data Range: 20.0 V to 40.0 V

FTimer: Fault timer, fault must remain active for this time period before the fault is reported as active.

Bytes 6,7: 16 bit unsigned integer, byte 7 is the most significant byte
Resolution: 1 second/bit, no offset, no sign bit
Data Range: 0 to 60 seconds

PGN 65491, Index Byte Value = 10 - Equalizer Voltages Calibration

Message:	PGN 65491 (0xFFD3)
Message Type:	Broadcast
Source Address:	System controller, 216 (0xD8)
Intended Recipient:	Equalizer, 30 (0x1E)
Priority:	6
29 Bit identifier:	0x18FFD3D8
Transmission repetition rate:	1 second
Data length:	8 bytes

For all values below, the data values between 65280-65535 (0xFF00-0xFFFF) indicate not requested. For those data values, the parameter on the equalizer will not change.

Index Byte

Byte 1: Must be 10 (0x0A) for the Equalizer voltages calibration message.

Calibration Byte

Byte 1: 0x01 - 28V and 14V are connected to equalizer
0x02 - 24V and 12V are connected to equalizer

PGN 65492 – Equalizer Status

Message: PGN 65492 (0xFFD4)
 Message Type: Broadcast
 Source Address: Equalizer, 30 (0x1E)
 Intended Recipient: System Controller, 216 (0xD8)
 Priority: 6
 29 Bit identifier: 0x18FFD41E
 Transmission repetition rate: 3 second
 Data length: 8 bytes

Equalizer Status

- Byte 1: Bit 0,1 STATE_CAN_JSO – reflects the state of the equalizer based on the most recent CAN_JSO (jump start override) command
- Bit 2,3 STATE_ONOFF_EN – reflects the equalizer is enabled to be turned on and off by CAN Bus control commands. If active, the equalizer can be turned ON and OFF by the CAN_EQ_ONOFF command in the Equalizer Control 1 Message.
- Bit 4,5 EX24F – external 24 V fault
- Bit 6,7 EX12F – external 12 V fault

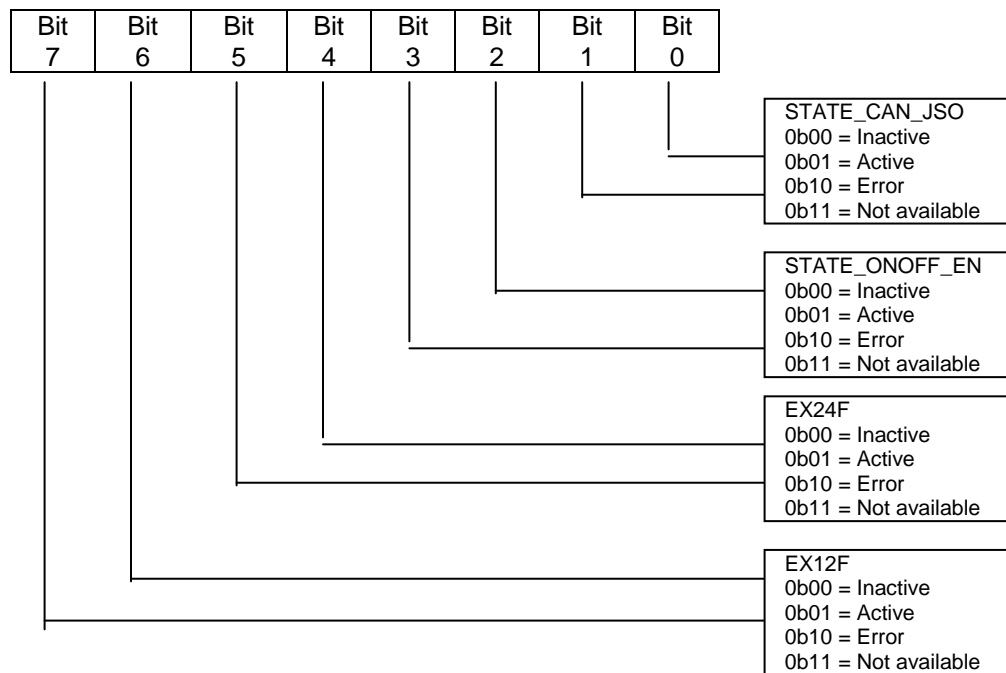

Byte 2: Bit 0,1 EXGNF – external ground fault
 Bit 2,3 OVF – over voltage fault
 Bit 4,5 UVF – under voltage fault
 Bit 6,7 IMB – battery string imbalance

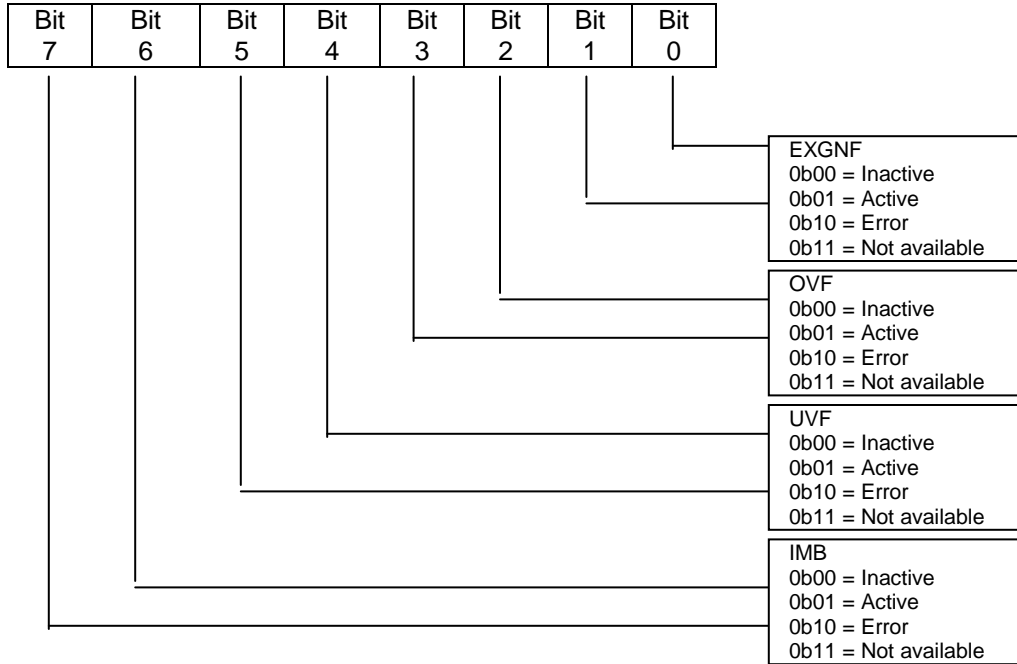

Byte 4: Bit 0,1 VCFH – voltage compensation fault high
 Bit 2,3 CAN_SS_MSG_ON – Indicates that the transmission of Smart Sensor messages on the CAN Bus from the equalizer are enabled (active, 0b01) or disabled (inactive, 0b00). The value is active by default.
 Bit 4,5 EQ_STATE_ONOFF – Indicates whether the equalizer is on or off. Note that the equalizer can be turned on or off via the CAN Bus only when STATE_ONOFF_EN is active.
 Bit 6,7 – EQ_BATTFLT – Equalizer battery fault, which is the OVF, UVF, and IMB faults combined. If any one of the three are active, the EQBATTFLT will be active. See the definition for Byte 3 above for more information on the three faults.

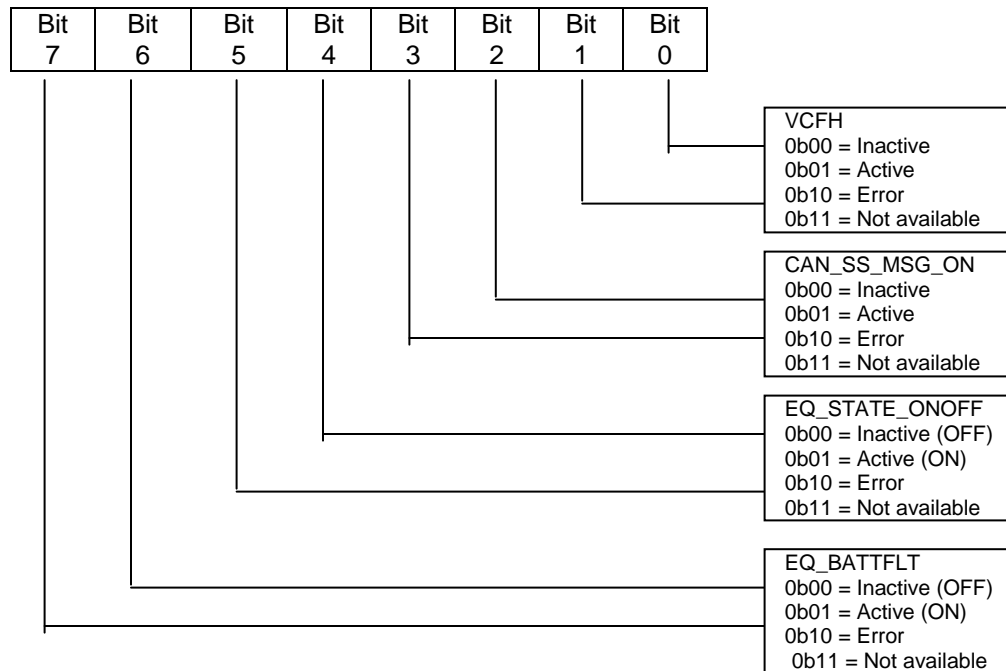

Bytes 5 – 8: Unused

PGN 65493 – Equalizer Heartbeat

Message: PGN 65493 (0xFFD5)
 Message Type: Broadcast
 Source Address: Equalizer, 30 (0x1E)
 Intended Recipient: System Controller, 216 (0xD8)
 Priority: 6
 29 Bit identifier: 0x18FFD51E
 Transmission repetition rate: 3 second
 Data length: 8 bytes

Equalizer Heartbeat

Byte 1:

Bit 0,1 CAN_EQ_HRTBEAT– Two bits that indicate a heartbeat message. The value of these two bits will alternate between 0b00 and 0b01
 Bits 2-7 are not used

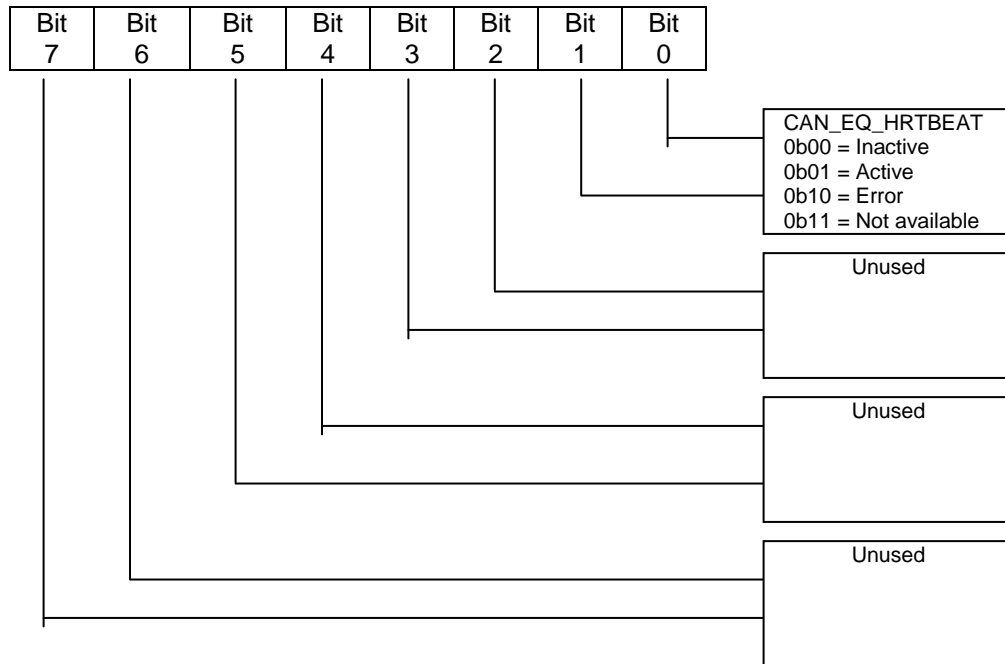

Bytes 2-7: unused

PGN 65494 – Voltages and Currents

Message:	PGN 65494 (0xFFD6)
Message Type:	Broadcast
Source Address:	Equalizer, 30 (0x1E)
Intended Recipient:	System Controller, 216 (0xD8)
Priority:	6
29 Bit identifier:	0x18FFD61E
Transmission repetition rate:	3 second
Data length:	8 bytes

V12: Equalizer DC Potential, +12V

Bytes 1,2:	16 bit unsigned integer, byte 2 the most significant byte
Resolution:	0.005 V/bit gain, 0V offset, no sign bit
Data Range:	0 to 327.675 V

V24: Equalizer DC Potential, +24V

Bytes 3,4:	16 bit unsigned integer, byte 4 is the most significant byte
Resolution:	0.005 V/bit gain, 0V offset, no sign bit
Data Range:	0 to 327.275 V

I12: Battery Current, +12V

Bytes 5,6:	16 bit unsigned integer, byte 6 is the most significant byte
Resolution:	0.05 A/bit gain, -1600 A offset
Data Range:	-1600 to 1612.75 A

I24: Battery Current, +24V

Bytes 7,8:	16 bit unsigned integer, byte 8 is the most significant byte
Resolution:	0.05 A/bit gain, -1600 A offset
Data Range:	-1600 to 1612.75 A

PGN 65497 – Index Byte Value = 1 - +12V Battery States 1

PGN 65497 messages contain information that pertains to the battery states as determined by the battery monitoring algorithms. The messages are indexed so that the first byte of the message indicates the message contents.

Message:	PGN 65497 (0xFFD9)
Message Type:	Broadcast
Source Address:	Equalizer, 30 (0x1E)
Intended Recipient:	System Controller, 216 (0xD8)
Priority:	6
29 Bit identifier:	0x18FFD91E
Transmission repetition rate:	5 seconds or as needed
Data length:	8 bytes

Index Byte

Byte 1: Must be 1 (0x01) for the Equalizer 12V Battery States 1 message.

SOCach: Achievable State of Charge in Percent

Bytes 2,3:	16 bit unsigned integer, byte 3 the most significant byte
Resolution:	0.1 %/bit gain, 0% offset, no sign bit
Data Range:	0 to 100.0 %, any value greater than 100.0% is invalid.

SOH: State of Health in Percent

Bytes 4,5:	16 bit unsigned integer, byte 5 the most significant byte
Resolution:	0.1 %/bit gain, 0% offset, no sign bit
Data Range:	0 to 100.0 %, any value greater than 100.0% is invalid.

U: Predicted Time to Run

Bytes 6,7:	16 bit unsigned integer, byte 7 the most significant byte
Resolution:	0.5 minute/bit gain, 0 minute offset, no sign bit
Data Range:	0 to 32675.5 minutes

PGN 65497 – Index Byte Value = 2 - +12V Battery States 2

PGN 65497 messages contain information that pertains to the battery states as determined by the battery monitoring algorithms. The messages are indexed so that the first byte of the message indicates the message contents.

Message:	PGN 65497 (0xFFD9)
Message Type:	Broadcast
Source Address:	Equalizer, 30 (0x1E)
Intended Recipient:	System Controller, 216 (0xD8)
Priority:	6
29 Bit identifier:	0x18FFD91E
Transmission repetition rate:	5 seconds or as needed
Data length:	8 bytes

Index Byte

Byte 1: Must be 2 (0x02) for the Equalizer 12V Battery States 2 message.

Up: Predicted Time to Run, Adjusted for Battery Temperature

Bytes 2,3: 16 bit unsigned integer, byte 3 the most significant byte
Resolution: 0.5 minute/bit gain, 0 minute offset, no sign bit
Data Range: 0 to 32675.5 minutes

Dd: Depth of Discharge in Percent

Bytes 4,5: 16 bit unsigned integer, byte 5 the most significant byte
Resolution: 0.1 %/bit gain, 0% offset, no sign bit
Data Range: 0 to 100.0 %, any value greater than 100.0% is invalid.

SOC: State of Charge in Percent

Bytes 6,7: 16 bit unsigned integer, byte 7 the most significant byte
Resolution: 0.1 %/bit gain, 0% offset, no sign bit
Data Range: 0 to 100.0 %, any value greater than 100.0% is invalid.

PGN 65497 – Index Byte Value = 3 - +24V Battery States 1

PGN 65497 messages contain information that pertains to the battery states as determined by the battery monitoring algorithms. The messages are indexed so that the first byte of the message indicates the message contents.

Message:	PGN 65497 (0xFFD9)
Message Type:	Broadcast
Source Address:	Equalizer, 30 (0x1E)
Intended Recipient:	System Controller, 216 (0xD8)
Priority:	6
29 Bit identifier:	0x18FFD91E
Transmission repetition rate:	5 seconds or as needed
Data length:	8 bytes

Index Byte

Byte 1: Must be 3 (0x03) for the Equalizer 24V Battery States 1 message.

SOCach: Achievable State of Charge

Bytes 2,3: 16 bit unsigned integer, byte 3 the most significant byte
Resolution: 0.1 %/bit gain, 0% offset, no sign bit
Data Range: 0 to 100.0 %, any value greater than 100.0% is invalid.

SOH: State of Health in Percent

Bytes 4,5: 16 bit unsigned integer, byte 5 the most significant byte
Resolution: 0.1 %/bit gain, 0% offset, no sign bit
Data Range: 0 to 100.0 %, any value greater than 100.0% is invalid.

U: Predicted Time to Run

Bytes 6,7: 16 bit unsigned integer, byte 7 the most significant byte
Resolution: 0.5 minute/bit gain, 0 minute offset, no sign bit
Data Range: 0 to 32675.5 minutes

PGN 65497 – Index Byte Value = 4 - +24V Battery States 2

PGN 65497 messages contain information that pertains to the battery states as determined by the battery monitoring algorithms. The messages are indexed so that the first byte of the message indicates the message contents.

Message:	PGN 65497 (0xFFD9)
Message Type:	Broadcast
Source Address:	Equalizer, 30 (0x1E)
Intended Recipient:	System Controller, 216 (0xD8)
Priority:	6
29 Bit identifier:	0x18FFD91E
Transmission repetition rate:	5 seconds or as needed
Data length:	8 bytes

Index Byte

Byte 1: Must be 4 (0x04) for the Equalizer 24V Battery States 2 message.

Up: Predicted Time to Run, Adjusted for Battery Temperature

Bytes 2,3:	16 bit unsigned integer, byte 3 the most significant byte
Resolution:	0.5 minute/bit gain, 0 minute offset, no sign bit
Data Range:	0 to 32675.5 minutes

Dd: Depth of Discharge in Percent

Bytes 4,5:	16 bit unsigned integer, byte 5 the most significant byte
Resolution:	0.1 %/bit gain, 0% offset, no sign bit
Data Range:	0 to 100.0 %, any value greater than 100.0% is invalid.

SOC: State of Charge in Percent

Bytes 6,7:	16 bit unsigned integer, byte 7 the most significant byte
Resolution:	0.1 %/bit gain, 0% offset, no sign bit
Data Range:	0 to 100.0 %, any value greater than 100.0% is invalid.

PGN 65497 – Index Byte Value = 5 - Battery Status

PGN 65497 messages contain information that pertains to the battery states as determined by the battery monitoring algorithms. The messages are indexed so that the first byte of the message indicates the message contents.

Message:	PGN 65497 (0xFFD9)
Message Type:	Broadcast
Source Address:	Equalizer, 30 (0x1E)
Intended Recipient:	System Controller, 216 (0xD8)
Priority:	6
29 Bit identifier:	0x18FFD91E
Transmission repetition rate:	5 seconds or as needed
Data length:	8 bytes

Index Byte

Byte 1: Must be 5 (0x05) for the Equalizer Battery States message.

SMajor: Major State of 12V Battery

Byte 2: 8 bit unsigned integer

SMinor: Minor State of 12V Battery

Byte 3: 8 bit unsigned integer

SMajor: Major State of 24V Battery

Byte 4: 8 bit unsigned integer

SMinor: Minor State of 24V Battery

Byte 5: 8 bit unsigned integer

Temp: Temperature

Bytes 6,7: 16 bit unsigned integer, byte 7 the most significant byte
Resolution: 0.1 degree C /bit gain, -3000 degree C offset, no sign bit
Data Range: -3000 to 3553.5

PGN 65498 – 65499

No commands are presently implemented for PGNs 65497-65499.

PGN 59904 – Request PGN

The Request PGN provides the capability to request information globally or from a specific destination.

Message:	PGN 59904 (0xEA00)
Message Type:	Broadcast
Source Address:	Any device, for DM1 messages Clever Devices AVM system will have Source Address of 65 (0x41)
Intended Recipient:	Equalizer, 30 (0x1E)
Priority:	6
29 Bit identifier:	0x18FFD5(SA), where SA = source address
Transmission repetition rate:	as needed
Data length:	8 bytes

PGN Being Requested

Byte 1:	Most significant byte of the full PGN being requested, usually all 0's
Byte 2:	PDU Format Field of PGN being requested
Byte 3:	PDU Specific Field of PGN being requested.
Bytes 4-8:	Not used

DM1 Diagnostic Message Support

The 81 Equalizer Can Bus Interface supports SAE J1939 Diagnostic Message 1 (DM1) for active Diagnostic Trouble Codes. The DM1 message contains information that indicates currently active Diagnostic Trouble Codes (DTC), preceded by the diagnostic lamp status. See section 5.7.1 of J1939-73 (Application Layer – Diagnostics) for an explanation of the format and data fields of a DM1 message. The intended recipient for DM1 messages is the Information System Controller #1, which is defined as a J1939 Preferred Address. The Address for Information System Controller #1 is 65 (0x41).

DM1 message criteria are:

- A DM1 message is transmitted using Parameter Group Number 65226, with PDU Format = 254 and PDU Specific = 202.
- A DM1 message is not normally transmitted when there are no active DTC's.
- A DM1 message is transmitted when one or more DTC's become active, and at one second intervals thereafter.
- If a fault has been active for 1 second or longer, and then becomes inactive, a single DM1 message is transmitted to reflect the state change.
- If a different DTC changes state within the 1 second update period, a new DM1 message is transmitted immediately to reflect the new DTC. However, to prevent a high message rate due to intermittent faults with a very high frequency, there will be no more than one state change transmitted per DTC per second.
- A DM1 message may be transmitted in response to a Request Message. If there are no active DTC's when the CAN Interface receives the request, it transmits the DM1 message with the data fields set at values that indicate there are no active DTC's. See SAE J1939-21, section 5.4.2 for more details on Request messages.
- When more than one active DTC exists, transmitting the DM1 message requires the use of the "Multipacket Transport" Parameter Group, specifically the Broadcast Announce Message. See SAE J1939-21, section 5.10 for a complete definition of the Transport Protocol. For Broadcast Announce Message (BAM) details see 5.10.3.5 of J1939-73.

The conditions that cause active Diagnostic Trouble Codes and the associated SPN's and FMI are for the Equalizer is show below in Table 2. The SPN's for the over and under voltage faults are defined in J1939. The SPN's for imbalance and Equalizer Fault are proprietary. All DM1 messages for the equalizer use the SPN Conversion Method = 0, which conforms to Version 4. See J1939-73, section 5.7.1.7 for a description of SPN Conversion Methods.

DTC	SPN	FMI	FMI Description
Over Voltage Fault (OVF)	168 (0x000A8)	0	Data valid, but above normal operating range – Most Severe
Under Voltage Fault (UVF)	168 (0x000A8)	1	Data valid, but below normal operating range – Most Severe
Imbalance (IMB)	520448 (0x7F100)	0	Data valid, but above normal operating range – Most Severe
Equalizer Fault (EQFLT)	520449 (0x7F101)	1	Data valid, but below normal operating range – Most Severe

Table 2 - DTC Definitions, SPN's and FMI values

PGN 65226 – Active Diagnostic Codes (DM1) Data Formats

Message: PGN 65526 (0xFECA)
 Message Type: Broadcast
 Source Address: Equalizer, 30 (0x1E)
 Intended Recipient: Equalizer, 65 (0x41)
 Priority: 6
 29 Bit identifier: 0x18FECA1E
 Transmission repetition rate: Upon Change in DTC, upon request, or 1 second
 Data length: Variable

DM1 Data Field Format – No Active DTC's

When there are no active DTC's, the equalizer does not normally transmit DM1 messages. However, in response to a Request PGN message, the equalizer will transmit a single frame DM1 message that indicates no active DTC's. In addition, when the equalizer transitions from a state where it has active DTC's to a state where it has no active DTC's, it will transmit the same message. The data fields for the DM1 message with no active DTC's is:

Byte 1: 0x00 – All Lamp Status Codes are off
 Byte 2: 0xFF – All bits reserved
 Byte 3: 0x00 – Recommended setting for not active DTC's
 Byte 4: 0x00 – Recommended setting for not active DTC's
 Byte 5: 0x00 – Recommended setting for not active DTC's
 Byte 6: 0x00 – Recommended setting for not active DTC's
 Byte 7: 0xFF – Not used
 Byte 8: 0xFF – Not used

Data length is 8.

Byte 1	Byte 2	Byte 3	Byte 4	Byte 5	Byte6	Byte 7	Byte 8
0x00	0xFF	0x00	0x00	0x00	0x00	0xFF	0xFF

DM1 Data Field Format – Single Frame Message, Active DTC is Over Voltage Fault

Byte 1: 0x08 Amber Warning Lamp is on.
 Byte 2: 0x00 All bits reserved.
 Byte 3: 0xA8 8 least significant bits of SPN
 Byte 4: 0x00 Second byte of SPN
 Byte 5: 0x00 Bits 8-6 = 3 most significant bits of SPN
 Bits 5-1 = FMI (0)
 Byte 6: OC Bit 8 = SPN Conversion Method (0)
 Bits 7-1 = Occurrence Count, OC.
 Byte 7: 0xFF Not used.
 Byte 8: 0xFF Not used

Byte 1	Byte 2	Byte 3	Byte 4	Byte 5	Byte6	Byte 7	Byte 8
0x08	0x00	0xA8	0x00	0x00	OC	0x00	0x00

DM1 Data Field Format – Single Frame Message, Active DTC is Under Voltage Fault

Byte 1: 0x08 Amber Warning Lamp is on.
 Byte 2: 0x00 All bits reserved.
 Byte 3: 0xA8 8 least significant bits of SPN
 Byte 4: 0x00 Second byte of SPN
 Byte 5: 0x01 Bits 8-6 = 3 most significant bits of SPN
 Bits 5-1 = FMI (1)
 Byte 6: OC Bit 8 = SPN Conversion Method (0)
 Bits 7-1 = Occurrence Count, OC.
 Byte 7: 0xFF Not used.
 Byte 8: 0xFF Not used

Byte 1	Byte 2	Byte 3	Byte 4	Byte 5	Byte6	Byte 7	Byte 8
0x08	0x00	0xA8	0x00	0x01	OC	0x00	0x00

DM1 Data Field Format – Single Frame Message, Active DTC is Imbalance

Byte 1: 0x08 Amber Warning Lamp is on.
 Byte 2: 0x00 All bits reserved.
 Byte 3: 0x00 8 least significant bits of SPN
 Byte 4: 0xF1 Second byte of SPN
 Byte 5: 0xE0 Bits 8-6 = 3 most significant bits of SPN
 Bits 5-1 = FMI (1)
 Byte 6: OC Bit 8 = SPN Conversion Method (0)
 Bits 7-1 = Occurrence Count, OC.
 Byte 7: 0xFF Not used.
 Byte 8: 0xFF Not used

Byte 1	Byte 2	Byte 3	Byte 4	Byte 5	Byte 6	Byte 7	Byte 8
0x08	0x00	0x00	0xF1	0xE0	0C	0x00	0x00

DM1 Data Field Format – Single Frame Message, Active DTC is Equalizer Fault

Byte 1: 0x08 Amber Warning Lamp is on.
 Byte 2: 0x00 All bits reserved.
 Byte 3: 0x01 8 least significant bits of SPN
 Byte 4: 0xF1 Second byte of SPN
 Byte 5: 0xE1 Bits 8-6 = 3 most significant bits of SPN
 Bits 5-1 = FMI (1)
 Byte 6: 0C Bit 8 = SPN Conversion Method (0)
 Bits 7-1 = Occurrence Count, OC.
 Byte 7: 0xFF Not used.
 Byte 8: 0xFF Not used

Byte 1	Byte 2	Byte 3	Byte 4	Byte 5	Byte 6	Byte 7	Byte 8
0x08	0x00	0x01	0xF1	0xE1	0C	0xFF	0xFF

DM1 Data Field Format – Multiple Frame Messages, Multiple Active DTC's

In the event that multiple active DTC's occur at once on the equalizer, the DM1 message must be transmitted in multiple frames. The multiple frames are broadcast using the Transport Protocol with a connection management type of Broadcast Announce Message (BAM). The frame data fields for the BAM connection management and for the BAM data transfer messages are addressed in this section.

BAM Connection Management Message

Message: PGN 60416 (0xEC00)
 Message Type: Broadcast
 Source Address: Equalizer, 30 (0x1E)
 Intended Recipient: Broadcast, 255 (0xFF)
 Priority: 6
 29 Bit identifier: 0x18ECFF1E
 Transmission repetition rate: When required. 1 second when active.
 Data length: 8 bytes

Byte 1: 0x20 Control Byte = BAM
 Byte 2: Variable DM1 message size in bytes, low byte
 Byte 3: Variable DM1 message size in bytes, high byte
 Byte 4: Variable DM1 message number of packets
 Byte 5: 0xFF Reserved
 Byte 6: 0xCA DM1 PGN low byte
 Byte 7: 0xFE DM1 PGN middle byte
 Byte 8: 0x00 DM1 PGN high byte

Byte 1	Byte 2	Byte 3	Byte 4	Byte 5	Byte6	Byte 7	Byte 8
0x20	Var	Var	Var	0xFF	0xCA	0xFE	0x00

BAM Data Transfer Message

Message: PGN 60160 (0xEB00)
 Message Type: Broadcast
 Source Address: Equalizer, 30 (0x1E)
 Intended Recipient: Broadcast, 255 (0xFF)
 Priority: 7
 29 Bit identifier: 0x18EBFF1E
 Transmission repetition rate: When required. 1 second when active.
 Data length: 8 bytes

First message:

Byte 1: 0x01 Packet Sequence Number
 Byte 2: 0 or 0x08 DM1 Lamp Status
 Byte 3: 0x00 Reserved
 Byte 4: DTC 1 SPN low bits
 Byte 5: DTC1 SPN middle bits
 Byte 6: DTC1 SPN upper 3 bits, FMI
 Byte 7: DTC1 CM, occurrence count
 Byte 8: DTC2 SPN low bits

Second Message:

Byte 1: 0x02 Packet Sequence Number
 Byte 2: DTC2 SPN middle bits
 Byte 3: DTC2 SPN upper 3 bits, FMI
 Byte 4: DTC1 CM, occurrence count
 Byte 5: DTC3 SPN low bits or 0xFF
 Byte 6: DTC3 SPN middle bits or 0xFF
 Byte 7: DTC3 SPN upper 3 bits, FMI or 0xFF
 Byte 8: DTC3 CM, occurrence count

Third Message:

Byte 1: 0x03 Packet Sequence Number
 Byte 2: DTC4 SPN low bits or 0xFF
 Byte 3: DTC4 SPN middle bits or 0xFF
 Byte 4: DTC4 SPN upper 3 bits, FMI or 0xFF
 Byte 5: DTC4 CM, occurrence count
 Byte 6: DTC5 SPN low bits or 0xFF
 Byte 7: DTC5 SPN middle bits or 0xFF
 Byte 8: DTC5 SPN upper 3 bits, FMI or 0xFF

Additional packets may be transmitted if there are more active DTC's. Also, only one DM1 Lamp Status is transmitted if more than once DTC is active.

Component and Software Revision Messages

PGN 59904 – Request PGN

The Request PGN provides the capability to request information globally or from a specific destination.

Message:	PGN 59904 (0xEA00)
Message Type:	Broadcast
Source Address:	Any device, for DM1 messages Clever Devices AVM system will have Source Address of 65 (0x41)
Intended Recipient:	Equalizer, 30 (0x1E)
Priority:	6
29 Bit identifier:	0x18EA1E(SA), where SA = source address, 0x18EA1E41 for Clever Devices
Transmission repetition rate:	as needed
Data length:	8 bytes

PGN Being Requested

Byte 1:	Most significant byte of the full PGN being requested, usually all 0's (byte 3).
Byte 2:	PDU Format Field of PGN being requested (byte 2).
Byte 3:	PDU Specific Field of PGN being requested (byte 3).
Bytes 4-8:	Not used

Presently, the Request Message supports requests for DM1, Software ID, and Component ID messages.

PGN 65259 – Component Identification

Message:	PGN 65259 (0xFEED)
Message Type:	Broadcast
Source Address:	Equalizer, 30 (0x1E)
Intended Recipient:	Any
Priority:	6
29 Bit identifier:	0x18FEED1E
Transmission repetition rate:	User Requested
Data length:	8

Model

This message data is by an ASCII “*”. This field is filled with the ASCII characters “EQ80xx” where the “xx” is the model number of the unit. For the FIRST revision it will be “01” for version “1”. Each time the hardware is revised, the revision number will be incremented to “02”, “03”, etc. This field is delimited by an ASCII “*”. For revision 01, the data fields are as follows:

Byte 1:	0x2A	“*”
Byte 2:	0x45	“E”

Byte 3: 0x51	“Q”
Byte 4: 0x38	“8”
Byte 5: 0x30	“0”
Byte 6: 0x30	“0”
Byte 7: 0x31	“1”
Byte 8: 0x2A	“*”

PGN 65242 – Software Identification

Message:	PGN 65242 (0xFEDA)
Message Type:	Broadcast
Source Address:	Equalizer, 30 (0x1E)
Intended Recipient:	Any
Priority:	6
29 Bit identifier:	0x18FEDA1E
Transmission repetition rate:	User Requested
Data length:	8

Message

For the 81 Series CAN Equalizer, the software ID will read as follows: “EQ80xx” where the “xx” will be the software version number. For the first version it will be “01” for version 1. Each time the software is revised, the revision number will be incremented to “02”, “03”, etc. This means that there will be 7 Data bytes outside of the first byte including the delimiter “*”.

Byte 1: 0x31	Number of Software ID Fields (“1”)
Byte 2: 0x45	“E”
Byte 3: 0x51	“Q”
Byte 4: 0x38	“8”
Byte 5: 0x30	“0”
Byte 6: 0x30	“0”
Byte 7: 0x31	“1”
Byte 8: 0x2A	“*”

Notes:

Vanner Incorporated
4282 Reynolds Drive
Hilliard, Ohio 43026

1-800-AC POWER
(1-800-227-6937)
Tel: 614-771-2718
Fax: 614-771-4904

www.vanner.com
e-mail: pwrsales@vanner.com

Part Number D915055A
January 15, 2010
Printed in U.S.A.