

EG4[®] WALLMOUNT 314Ah INDOOR BATTERY

USER MANUAL



TABLE OF CONTENTS

1.	TECHNICAL SPECIFICATIONS.....	1
2.	WALLMOUNT 314AH INDOOR DC ESS SPECIFICATIONS	3
3.	ABBREVIATIONS	4
4.	BATTERY SAFETY	5
4.1	SAFETY INSTRUCTIONS.....	5
4.2	IMPORTANT SAFETY NOTIFICATIONS.....	5
5.	SÉCURITÉ DE LA BATTERIE.....	9
5.1	CONSIGNES DE SÉCURITÉ.....	9
5.2	NOTIFICATIONS DE SÉCURITÉ IMPORTANTES.....	9
6.	PRODUCT OVERVIEW	15
6.1	BATTERY DIMENSIONS	16
6.2	PACKING LIST	17
6.3	BMS OVERVIEW	17
6.4	STORAGE INFORMATION	18
6.5	BATTERY PERFORMANCE CURVES	19
6.6	BATTERY CHARGING.....	20
6.7	FRONT PANEL INDICATOR LIGHTS.....	20
7.	GENERAL INSTALLATION.....	21
7.1	RECOMMENDED TOOLS	21
7.2	LOCATION REQUIREMENTS	22
7.3	BATTERY INSTALLATION.....	23
7.4	BATTERY WITH CONDUIT BOX.....	27
7.5	BATTERY, CONDUIT BOX, & 18KPV	29
7.6	BATTERY, CONDUIT BOX, & 12KPV/FLEXBOSS18/21.....	31
8.	CONNECTING MULTIPLE BATTERIES IN PARALLEL	33
8.1	BMS COMMUNICATION WIRING	33
8.2	BATTERY CABLE CONNECTIONS	35
9.	BATTERY COMMUNICATIONS.....	42
9.1	AUTO-ID BMS PROTOCOL FEATURE	42
9.2	BMS AUTO-ID PROCEDURE.....	42
9.3	COMMUNICATION CABLE PINOUT.....	43
10.	BATTERY STARTUP AND SHUTDOWN PROCEDURE.....	44
10.1	STARTUP	44
10.2	SHUTDOWN	44
11.	EMERGENCY STOP [RSD/ESS DISCONNECT].....	45
11.1	CABLING	45
12.	BMS TOOLS	46
12.1	OVERVIEW.....	46
12.2	DOWNLOADING AND INSTALLING BMS TOOLS	46
13.	TROUBLESHOOTING, MAINTENANCE & DISPOSAL.....	47
13.1	LED INDICATOR STATUS AND DEFINITION.....	47
13.2	MAINTENANCE.....	49
13.3	FIRMWARE UPDATE	49
13.4	BATTERY END OF LIFE.....	50
14.	WARRANTY INFORMATION	51
15.	CHANGELOG	52

1. TECHNICAL SPECIFICATIONS

TYPE & MODEL #		
PARAMETER	SPECIFICATION	
PRODUCT TYPE	LFP Battery	
BATTERY TYPE	Lithium Iron Phosphate (LFP)	
MODEL NUMBER	WM-48-314-IN-XX / WM48314INXX (XX is a number between 00 – 99)	
ELECTRICAL CHARACTERISTICS		
NOMINAL ENERGY CAPACITY	16kWh	
USABLE ENERGY (DOO%)	12.86kWh (80% recommended)	
RECOMMENDED VOLTAGE RANGE	47.5 – 57.6 VDC	
NOMINAL VOLTAGE	51.2 VDC	
CAPACITY	314Ah	
CHARGING VOLTAGE RANGE	56 – 57 VDC	
DISCHARGING CUT-OFF VOLTAGE	47.5 VDC	
MAX CONTINUOUS/RECOMMENDED CHARGE CURRENT	157A/157A	
MAX CONTINUOUS/RECOMMENDED DISCHARGE CURRENT	200A/157A	
CONTINUOUS CHARGE/DISCHARGE POWER	8/10.2 kW	
RECOMMENDED CHARGING/DISCHARGING RATE	0.5C	
SHORT CIRCUIT CURRENT	1700A, 15ms delay	
PEAK POWER	12.8kW (3 sec)	
ROUND-TRIP EFFICIENCY	95%	
MAX PARALLEL UNITS	32	
PROTECTION FEATURES	Over/Under Voltage, Over-Current, Short Circuit, High/Low Temp	
BATTERY MANAGEMENT SYSTEM [BMS]	Integrated, Active Balancing	
COMMUNICATION PROTOCOLS	RS485, CAN	
BATTERY BREAKER	250A	
BATTERY HEATER SPECIFICATIONS		
PARAMETER	SPEC	CONDITION
VOLTAGE	56V	-
POWER CONSUMPTION	448W	-
INTERNAL BATTERY TEMPERATURE	≤32°F (0°C)/≥37°F (3°C)	Heat On/Heat Off
ENVIRONMENTAL SPECIFICATIONS		
STORAGE TEMPERATURE RANGE*	-4 – 131°F (-20 – 55°C)	
HUMIDITY RANGE	5% – 95% RH (non-condensing)	
ALTITUDE	9843 ft. (<3000 m)	
COOLING METHOD	Natural Convection	
DIMENSIONS [H × W × D]	34.1 in. × 18.1 in. × 9.6 in. (865 mm × 460 mm × 245 mm)	
OPERATING TEMPERATURE RANGE	Charge: 32 – 122°F (0 – 50°C) Discharging: -4 – 131°F (-20 – 55°C)	

*Less than 3 months of storage. If longer than 3 months, the recommended storage temperature will be 59°F – 86°F (15°C – 30°C). Refer to section 6.4 for complete storage requirements.

MECHANICAL SPECIFICATIONS

PARAMETER	SPECIFICATION
WEIGHT	293.2 lbs. (133 kg)
ENCLOSURE RATING	IP20
MOUNTING OPTIONS	Floor mount/wall attached
DISPLAY/INDICATORS	LED Status
CONNECTOR TYPE	Degson quick connector/screw terminal

CERTIFICATIONS & COMPLIANCE

UL 1973	Yes
UL 9540	See https://eg4electronics.com/ for supported UL 9540 configurations
UL 9540A	Yes

WARRANTY & LIFECYCLE

CYCLE LIFE (70% EOL CAPACITY)*	10000 cycles @ 0.5C, 25°C, 80% DOD
DESIGN LIFE	15 years
WARRANTY	10 years or 10000 cycles
LIFETIME PRODUCTION**	122.2 MWh
APPLICATION TYPE	Residential/Commercial/Off-grid/Backup

*EG4 recommends this value be set no lower than 20% to maintain the recommended 80% Depth of Discharge.

** $(51.2V \times 314Ah / 1000 \times 80\% \times 10000 / 1000) \times 95\% = 122.2 \text{ MWh}$ or
 $(12861 \text{ kWh} \times 10000 \text{ cycles} \times 95\% \text{ efficiency}) = 122.2 \text{ MWh}$

2. WALLMOUNT 314AH INDOOR DC ESS SPECIFICATIONS

MODEL	WM-48-314-IN-00 to 99*	WM-48-314-2-IN-00 to 99*	WM-48-314-3-IN-00 to 99*	WM-48-314-4-IN-00 to 99*	WM-48-314-5-IN-00 to 99*	WM-48-314-6-IN-00 to 99*
BATTERY DATA						
BATTERY TYPE	LiFePO4					
TOTAL ENERGY	16kWh	32kWh	48kWh	64kWh	80kWh	96kWh
VOLTAGE RANGE	44.8 – 56 VDC					
NOMINAL VOLTAGE	51.2V					
MAX. CHARGE CURRENT	157A DC	314A DC	471A DC	628A DC	785A DC	942A DC
MAX. DISCHARGE CURRENT	200A DC	400A DC	600A DC	800A DC	1000A DC	1200A DC
PARALLEL NUMBER	1S1P	1S2P	1S3P	1S4P	1S5P	1S6P
SHORT CIRCUIT CURRENT RATING [SCCR] & DURATION	1700A, 15 ms delay	1950A, 15 ms delay	1950A, 15 ms delay	1950A, 15 ms delay	1950A, 15 ms delay	1950A, 15 ms delay
ENVIRONMENTAL SPECIFICATIONS						
OPERATING TEMPERATURE RANGE	Charge: 32 – 122°F (0 – 50°C) Discharging: -4 – 131°F (-20 – 55°C)					
INSTALL LOCATION	Battery IP20, Indoor Use Only					

3. ABBREVIATIONS

- AWG – American Wire Gauge
- A – Amps
- Ah – Amp hour(s)
- AC – Alternating Current
- AFCI – Arc-Fault Circuit Interrupter
- AHJ – Authority Having Jurisdiction
- kAIC – kilo-Amp Interrupting Capability
- ANSI – American National Standards Institute
- BAT – Battery
- BMS – Battery Management System
- COM – Communication
- CT – Current Transformer
- DC – Direct Current
- DIP – Dual In-line Package
- DOD – Depth of Discharge
- EG – Equipment Ground
- EGS – Equipment Grounding System
- EMC – Electromagnetic Compatibility
- EPS – Emergency Power System
- ESS – Energy Storage System
- E-Stop – Emergency Stop
- FCC – Federal Communication Commission
- GE – Grounding Electrode
- GEC – Grounding Electrode Conductor
- GFCI – Ground Fault Circuit Interrupter
- GFDI – Ground Fault Detector/Interrupter
- Imp – Maximum Power Point Current
- IEEE – Institute of Electrical and Electronic Engineers
- IP – Ingress Protection
- I_{sc} – Short-Circuit Current
- In-lbs. – Inch Pounds
- kW – Kilowatt
- kWh – Kilowatt-hour
- LCD – Liquid Crystal Display
- LFP – Lithium Iron Phosphate
- L1 – Line 1
- L2 – Line 2
- mm – Millimeters
- MPPT – Maximum Power Point Tracking
- mV – Millivolt
- N – Neutral
- NEC – National Electric Code
- NEMA – National Electrical Manufacturers Association
- NFPA – National Fire Prevention Association
- Nm – Newton Meters
- NOCT – Normal Operating Cell Temperature
- PC – Personal Computer
- PCB – Printed Circuit Board
- PE – Protective Earth
- PPE – Personal Protective Equipment
- PV – Photovoltaic
- RSD – Rapid Shut Down
- SCC – Standards Council of Canada
- SOC – State of Charge
- STC – Standard Testing Conditions
- UL – Underwriters Laboratories
- UPS – Uninterrupted Power Supply
- V – Volts
- VOC – Open-Circuit Voltage
- VMP – Voltage Maximum Power

4. BATTERY SAFETY

4.1 SAFETY INSTRUCTIONS

Before beginning any work, carefully read and understand all safety instructions, and strictly follow them when working on or near the battery. Qualified service personnel must install the system in accordance with the installation instructions, using proper practices and complying with all applicable local electrical, building, fire, and utility codes and regulations. Consult the local Authority Having Jurisdiction (AHJ) to obtain the required permits and approvals before installation.

Incorrect installation may cause:

- Injury or death to the installer, operator, or third party
- Damage to the battery or other attached equipment

4.2 IMPORTANT SAFETY NOTIFICATIONS



DANGER: Hazardous Voltage Circuits!

Observe all safety precautions before, during, and after installation. Follow these precautions during operation and maintenance. The following safety notifications apply to both installers and end users when using this product under normal conditions.

1. **Do not disassemble the battery:** Contact the distributor for repairs, troubleshooting, or proper handling instructions. Incorrect servicing or reassembly may create a risk of electric shock or fire and will void the warranty.
2. **The ESS uses DC current:** DC current can cause continuous muscle contraction during electric shock and may lead to severe burns or fire if one mishandles the product.
3. Damage to the ESS or improper installation can cause arc flashing, resulting in serious damage, injury, or death.
4. **Beware of high battery current:** Before installing or working on the battery, place all battery module breakers and on/off switches in the “OPEN” or “OFF” position. Use a voltmeter to verify that no voltage is present to prevent electric shock.
5. **Do not make any connections or disconnections to the system while the batteries are operating.** Working with energized batteries can damage system components and create a risk of electrical shock.
6. Verify that the batteries are properly grounded.
7. The installer must use appropriate, professional-grade insulating protective equipment at all times. [e.g., personal protective equipment (PPE)].
8. Before installing, operating, or maintaining the system, inspect all existing wiring to verify it meets the required specifications and is in proper condition for use.
9. Confirm that all battery and system component connections are secure and correctly installed to prevent damage or injury.
10. Battery rupture or short-circuiting of battery cells can release toxic gases and harmful electrolyte solutions.



WARNING: Read all instructions to reduce the risk of injury!

Qualified personnel must perform all system design, installation, operation, setup, configuration, and maintenance tasks for this product. To reduce the risk of electric shock, only carry out the servicing procedures specified in the operating instructions with qualified technicians.

11. Read all instructions before starting the installation. When performing electrical work, follow all local and national wiring standards, regulations, and these installation instructions. Install all wiring in accordance with the National Electrical Code (NEC), ANSI/NFPA 70.
12. Connect the battery and system to the utility grid only when the utility provider permits it. Before installing this product, consult the local Authority Having Jurisdiction (AHJ) to identify any additional regulations or requirements for your area.
13. Keep all warning labels and nameplates on the battery clearly visible at all times, and do not remove or cover them.
14. When selecting the battery's position and installation location, as specified in this manual, the installer must consider the safety of future users.
15. Keep children away from the battery and related systems to prevent contact or misuse.
16. The battery automatically stops charging when its temperature reaches the low-temperature threshold of 32°F (0°C). If users detect charging current while the internal battery temperature is below 32°F (0°C), they should immediately disconnect the battery and contact the distributor.



WARNING:

Cancer And Reproductive Harm – Visit www.P65Warnings.ca.gov for more information.

DISCLAIMER

EG4® reserves the right to revise this material at any time without prior notice. Refer to www.eg4electronics.com for the most current **versions of** manuals and specification sheets.



TAKE THESE ADDITIONAL PRECAUTIONS DURING INSTALLATION/REPLACEMENT

Ensure that all precautions listed above have been taken prior to beginning the installation and observe these additional precautions during installation. Failure to take these precautions may result in serious injury or death:



- **Thermal Runaway:** *Immediately stop the installation, place battery in a safe state if possible, and move away from the battery if the battery:*
 - *begins to swell or bulge,*
 - *if you smell any unusual odors,*
 - *if you hear a hissing sound, or*
 - *if the battery begins to emit heat and/or smoke.*

Your battery may be experiencing thermal runaway, a dangerous condition that may cause fire or explosion. *Contact local fire department, Chemtrec 800-262-8200, and EG4 support.*



- **Electrical Shock:** *When installing/replacing the battery:*
 - *Ensure that the battery does not get wet.*
 - *Do not spray water or other liquids on the battery.*
 - *Do not perform the installation in conditions where dust, moisture, or other debris could enter the battery.*
 - *Avoid touching connections and components unless instructed to do so by this guide.*
 - *Do not leave the battery unattended during the installation without it being in a safe state. Do not touch, lean on, or lay tools on the battery or connections.*

If you are electrically shocked during installation, place battery in a safe state if possible, and seek immediate medical attention.



- **Ventilation Warning:** *When installing/replacing the battery:*
 - *Do not open the battery.*
 - *Do not attempt the installation/replacement if the battery is damaged.*

Lithium batteries may emit toxic gases when ruptured. Do not attempt to repair the battery in the case of rupture. Move outdoors in the case of rupture and seek professional assistance.



- **Electrolyte Exposure:** *When installing/replacing the battery:*
 - *Ensure that the battery is not damaged.*
 - *Do not attempt the installation/replacement if the battery is damaged.*

Lithium batteries contain a liquid electrolyte solution that is corrosive and damaging to skin and eyes. Exposure may occur in the case of damage to the battery. In the case of contact with skin or eyes, wash continuously with water for 15 minutes and seek immediate medical attention. Remove contaminated clothes immediately. In the case of ingestion, drink at least two glasses of water or milk, induce vomiting if unconscious, and seek immediate medical attention.

5. SÉCURITÉ DE LA BATTERIE

5.1 CONSIGNES DE SÉCURITÉ

Avant de commencer tout travail, lisez attentivement toutes les consignes de sécurité et respectez-les toujours lorsque vous travaillez sur ou avec la batterie. L'installation doit être conforme à toutes les normes et réglementations nationales ou locales applicables. Consultez l'autorité compétente locale et/ou le service public pour obtenir les permis et les autorisations appropriés avant l'installation.

Une installation incorrecte peut entraîner les effets suivants :

Blessure ou décès de l'installateur, de l'exploitant ou d'un tiers
 Dommages à la batterie ou à tout autre équipement attaché

5.2 NOTIFICATIONS DE SÉCURITÉ IMPORTANTES



DANGER: Circuits à haute tension!

Il existe divers problèmes de sécurité qui doivent être soigneusement observés avant, pendant et après l'installation, ainsi que lors de l'utilisation et de la maintenance futures. Ce qui suit sont des notifications de sécurité importantes pour l'installateur et tout utilisateur final de ce produit dans des conditions de fonctionnement normales.

1. **Ne démontez pas la batterie.** Contactez le distributeur pour tout problème nécessitant une réparation pour plus d'informations et des instructions de manipulation appropriées. Un entretien ou un remontage incorrect peut entraîner un risque d'électrocution ou d'incendie et annuler la garantie.
1. **Ne court-circuitez jamais les entrées CC.** Un court-circuit de la batterie peut entraîner un risque d'électrocution ou d'incendie et peut entraîner des blessures graves ou la mort et/ou des dommages permanents à l'appareil et/ou à tout équipement connecté.
2. **Soyez prudent lorsque vous travaillez avec des outils métalliques sur ou à proximité des batteries et des systèmes.** Le risque d'arcs électriques et/ou de court-circuit de l'équipement peut entraîner des blessures graves ou la mort et des dommages à l'équipement.
3. **Attention au courant de batterie élevé.** Assurez-vous que les disjoncteurs du module de batterie et/ou les interrupteurs marche/arrêt sont en position « ouvert » ou « arrêt » avant d'installer ou de travailler sur la batterie. Utilisez un voltmètre pour confirmer qu'il n'y a pas de tension présente afin d'éviter les chocs électriques.
4. **N'effectuez aucune connexion ou déconnexion du système pendant que les batteries fonctionnent.** Des dommages aux composants du système ou un risque d'électrocution peuvent survenir si vous travaillez avec des batteries sous tension.
5. Assurez-vous que le banc de batteries est correctement mis à la terre.
6. Un installateur doit s'assurer d'être bien protégé par un équipement isolant raisonnable et professionnel [par exemple, un équipement de protection individuelle (EPI)].
7. Avant d'installer, d'utiliser ou d'entretenir le système, il est important d'inspecter tout le câblage existant pour s'assurer qu'il répond aux spécifications et aux conditions d'utilisation appropriées.
8. Assurez-vous que les connexions de la batterie et des composants du système sont sécurisées et appropriées pour éviter les dommages ou les blessures causés par une mauvaise installation.
9. La rupture de la batterie et le court-circuit des cellules de la batterie peuvent causer la libération de gaz toxiques et de solutions électrolytiques nocives.



AVERTISSEMENT : Pour réduire le risque de blessure, lisez toutes les instructions !

Tous les travaux sur ce produit (conception du système, installation, fonctionnement, réglage, configuration et maintenance) doivent être effectués par du personnel qualifié. Pour réduire le risque d'électrocution, n'effectuez aucun entretien autre que ceux spécifiés dans le mode d'emploi, à moins d'être qualifié pour le faire.

10. Lisez toutes les instructions avant de commencer l'installation. Pour les travaux électriques, suivez toutes les normes de câblage locales et nationales, les réglementations et ces instructions d'installation. Tout le câblage doit être conforme au Code national de l'électricité (NEC), ANSI/NFPA 70.
11. La batterie et le système ne peuvent se connecter au réseau public que si le fournisseur d'électricité l'autorise. Consultez l'AHJ local avant d'installer ce produit pour connaître les réglementations et exigences supplémentaires de la région.
12. Toutes les étiquettes d'avertissement et les plaques signalétiques de cette batterie doivent être clairement visibles et ne doivent pas être retirées ou couvertes.
13. L'installateur doit tenir compte de la sécurité des futurs utilisateurs lors du choix de la position et de l'emplacement corrects de la batterie, comme spécifié dans ce manuel.
14. Tenez les enfants à l'écart de la batterie et des systèmes concernés ou de les utiliser à mauvais escient.
15. La batterie est conçue pour arrêter de se charger lorsqu'elle atteint le seuil bas de 32 °F. Si un courant de charge est observé lorsque la température interne de la batterie est inférieure à 32 °F, débranchez immédiatement la batterie et consultez le distributeur.



AVERTISSEMENT !

Cancer et dommages reproductifs – Voir <http://www.P65Warnings.ca.gov> pour plus de détails.

DISCLAIMER

EG4® se réserve le droit de modifier le contenu de ce document à tout moment sans préavis. Veuillez consulter www.eg4electronics.com pour la version la plus récente de nos manuels/fiches techniques.



PRENEZ CES PRÉCAUTIONS SUPPLÉMENTAIRES LORS DE L'INSTALLATION OU DU REMPLACEMENT

Assurez-vous que toutes les précautions énumérées ci-dessus ont été prises avant de commencer l'installation et respectez ces précautions supplémentaires pendant l'installation. Le non-respect de ces précautions peut entraîner des blessures graves ou la mort.



- **Emballement thermique:** Arrêtez immédiatement l'installation, mettez la batterie dans un état sécuritaire si possible et éloignez-vous de la batterie si celle-ci :
 - commence à gonfler ou à se déformer,
 - dégage des odeurs inhabituelles,
 - émet un sifflement, ou
 - commence à dégager de la chaleur et/ou de la fumée.

La batterie peut être en situation d'emballement thermique, une condition dangereuse pouvant entraîner un incendie ou une explosion.

Communiquez avec le service d'incendie local, Chemtrec au 800-262-8200, et le soutien EG4.



- **Choc électrique:** Lors de l'installation ou du remplacement de la batterie :
 - Assurez-vous que la batterie ne soit pas mouillée.
 - Ne vaporisez pas d'eau ni d'autres liquides sur la batterie.
 - N'effectuez pas l'installation dans des conditions où de la poussière, de l'humidité ou d'autres débris pourraient pénétrer dans la batterie.
 - Évitez de toucher les connexions et les composants sauf indication contraire dans ce guide.
 - Ne laissez pas la batterie sans surveillance pendant l'installation si elle n'est pas dans un état sécuritaire
 - Ne touchez pas la batterie, ne vous appuyez pas dessus et ne déposez pas d'outils sur la batterie ou les connexions.

En cas de choc électrique pendant l'installation, mettez la batterie dans un état sécuritaire si possible et consultez immédiatement un professionnel de la santé.



- **Avertissement – Ventilation:** Lors de l'installation ou du remplacement de la batterie :

- *N'ouvrez pas la batterie.*
- *N'effectuez pas l'installation ou le remplacement si la batterie est endommagée.*

Les batteries au lithium peuvent émettre des gaz toxiques en cas de rupture. N'essayez pas de réparer la batterie si elle est rompue. En cas de rupture, déplacez-vous à l'extérieur et demandez l'assistance d'un professionnel qualifié.



- ***Exposition à l'électrolyte :*** *Lors de l'installation ou du remplacement de la batterie :*
 - *Assurez-vous que la batterie n'est pas endommagée.*
 - *N'effectuez pas l'installation ou le remplacement si la batterie est endommagée.*

Les batteries au lithium contiennent une solution d'électrolyte liquide corrosive et nocive pour la peau et les yeux. Une exposition peut survenir si la batterie est endommagée. En cas de contact avec la peau ou les yeux, rincez abondamment à l'eau pendant 15 minutes et consultez immédiatement un professionnel de la santé. Retirez immédiatement les vêtements contaminés. En cas d'ingestion, buvez au moins deux verres d'eau ou de lait, provoquez le vomissement si la personne est consciente, et consultez immédiatement un professionnel de la santé.

SYMBOLS USED IN MANUAL



WARNING:

This type of notation indicates that a hazard may pose a risk to human health and safety.



DANGER:

This type of notation indicates a severe hazard that presents an immediate risk of serious injury or death.



NOTE:

This type of notation indicates useful information.



IMPORTANT:

This type of notation indicates that the information provided is important for the installation, operation, and/or maintenance of the equipment. Failure to follow the recommendations in such a notation could result in the equipment warranty being voided.



CAUTION:

This type of notation indicates that the hazard could potentially damage the equipment.



REMINDER:

This type of notation indicates previously stated information that should be considered to ensure proper operation and safety.



TEAM LIFT:

Use team lift whenever load weight, size, or center of gravity exceeds safe single-person handling limits. Coordinated lifting improves stability, control, and significantly reduces injury risk.

SYMBOLS USED ON EQUIPMENT



WARNING:

Read the instructions before installation, operation, and maintenance of the system.



WARNING:

Read the instructions before installation, operation, and maintenance of the system.



WARNING:

Hazardous Voltage Circuits

SYMBOLES UTILISÉS DANS LE MANUEL



AVERTISSEMENT :

Ce type de signalisation indique qu'un danger peut présenter un risque pour la santé et la sécurité humaines.



DANGER :

Ce type de signalisation indique un danger grave présentant un risque immédiat de blessures graves, voire mortelles.



NOTE :

Ce type de notation indique des informations utiles.



IMPORTANT :

Ce type de notation indique que les informations fournies sont importantes pour l'installation, le fonctionnement et/ou l'entretien de l'équipement. Le non-respect des recommandations figurant dans cette notation pourrait entraîner l'annulation de la garantie de l'équipement.



PRUDENCE :

Ce type de notation indique que le danger pourrait potentiellement endommager l'équipement.



RAPPEL :

Ce type de notation indique des informations précédemment mentionnées qui doivent être prises en compte pour garantir un fonctionnement et une sécurité optimaux.



TEAM LIFT:

Utilisez le levage à deux personnes lorsque le poids, la taille ou le centre de gravité de la charge dépasse les limites de manutention sécuritaire pour une seule personne. Un levage coordonné améliore la stabilité, le contrôle et réduit considérablement le risque de blessure.

SYMBOLES UTILISÉS SUR L'ÉQUIPEMENT



AVERTISSEMENT :

Lisez les instructions avant l'installation, l'utilisation et l'entretien du système.



AVERTISSEMENT :

Lisez les instructions avant l'installation, l'utilisation et l'entretien du système.



AVERTISSEMENT :

Circuits à tension dangereuse.

6. PRODUCT OVERVIEW

The EG4[®] WallMount 314Ah Indoor Battery is designed for indoor, low-voltage residential energy storage applications. The battery uses lithium iron phosphate (LiFePO₄) cells that deliver high safety performance and long service life. An intelligent Battery Management System (BMS) continuously monitors and records each cell's voltage, current, and temperature in real time. The BMS also provides advanced protection features, including active cell balancing, enhanced battery control methods, and multiple integrated safety protections.

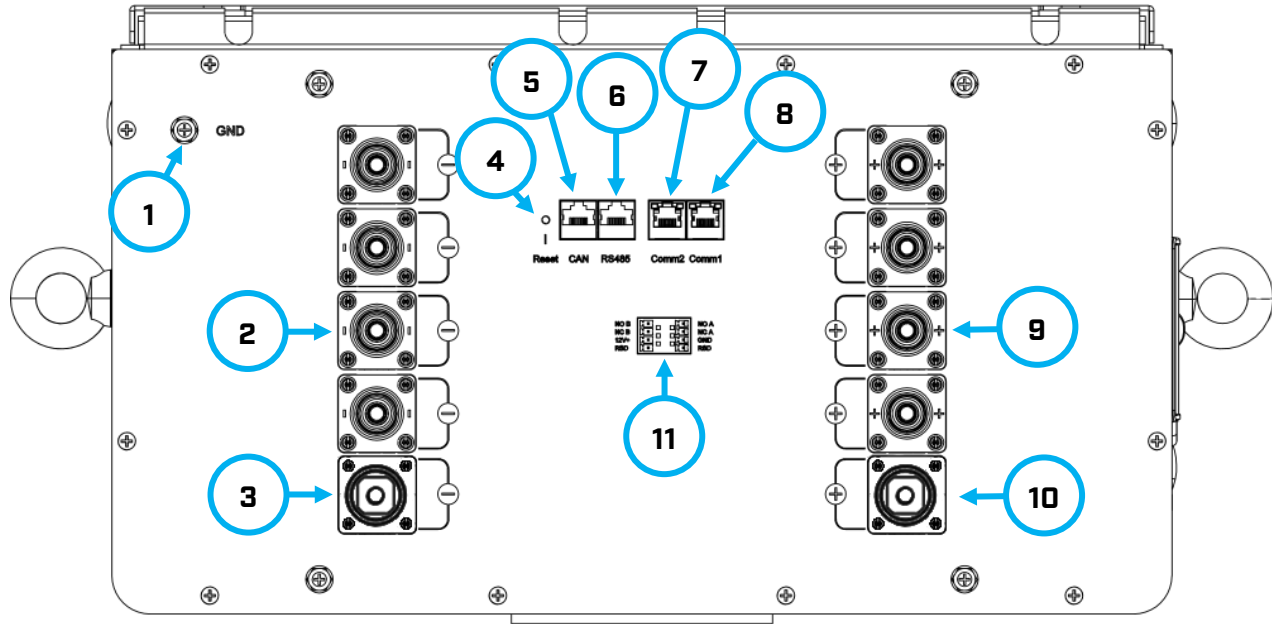

NO.	ITEM	DESCRIPTION	REMARKS
1	GND	Equipment Grounding Conductor (EGC)	For grounding the battery
2	Terminal	Negative × 4	250A rated Degson battery connectors
3	Terminal	Negative × 1	250A rated stud terminal
4	Reset	BMS Reset Button	-
5	CAN	CAN Communication Interface	For inverter communications
6	RS485	RS485 Communication Interface	For inverter communications
7	Battery Comm 2	Battery communication Paralleling	For multiple batteries in parallel
8	Battery Comm 1	Battery communication Paralleling	For multiple batteries in parallel
9	Terminal	Positive × 4	250A rated Degson battery connectors
10	Terminal	Positive × 1	250A rated stud terminal
11	Dry Contact	Normally Closed, Normally Open, Ground, RSD, 12V	For RSD control

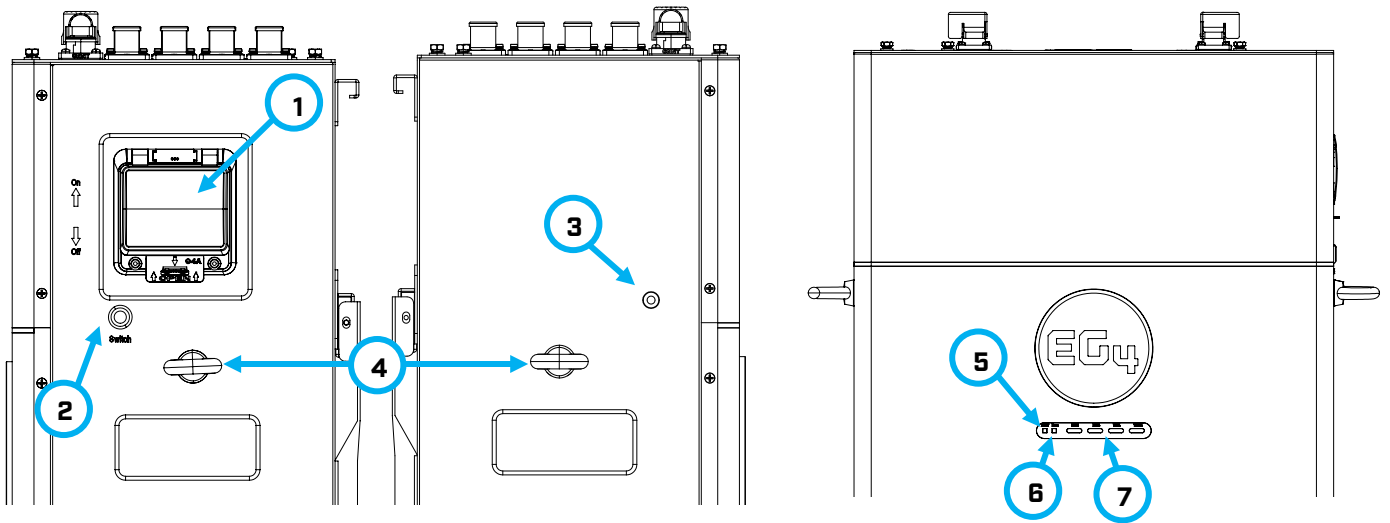

NO.	ITEM	DESCRIPTION	REMARKS
1	Breaker	Output switch and over current protection	-
2	ON/OFF Switch	Turn BMS on/off	-
3	Wi-Fi/Bluetooth Antenna	Network Connection	-
4	Lifting Eye Bolt	Threaded bolt with circular eye	For moving the battery
5	ALM	Alarm LED Display	To show alarm status
6	RUN	Run LED Display	To show normal operating status
7	SOC	State Of Charge Display	To show battery charge. Each LED indicates 25%

6.1 BATTERY DIMENSIONS

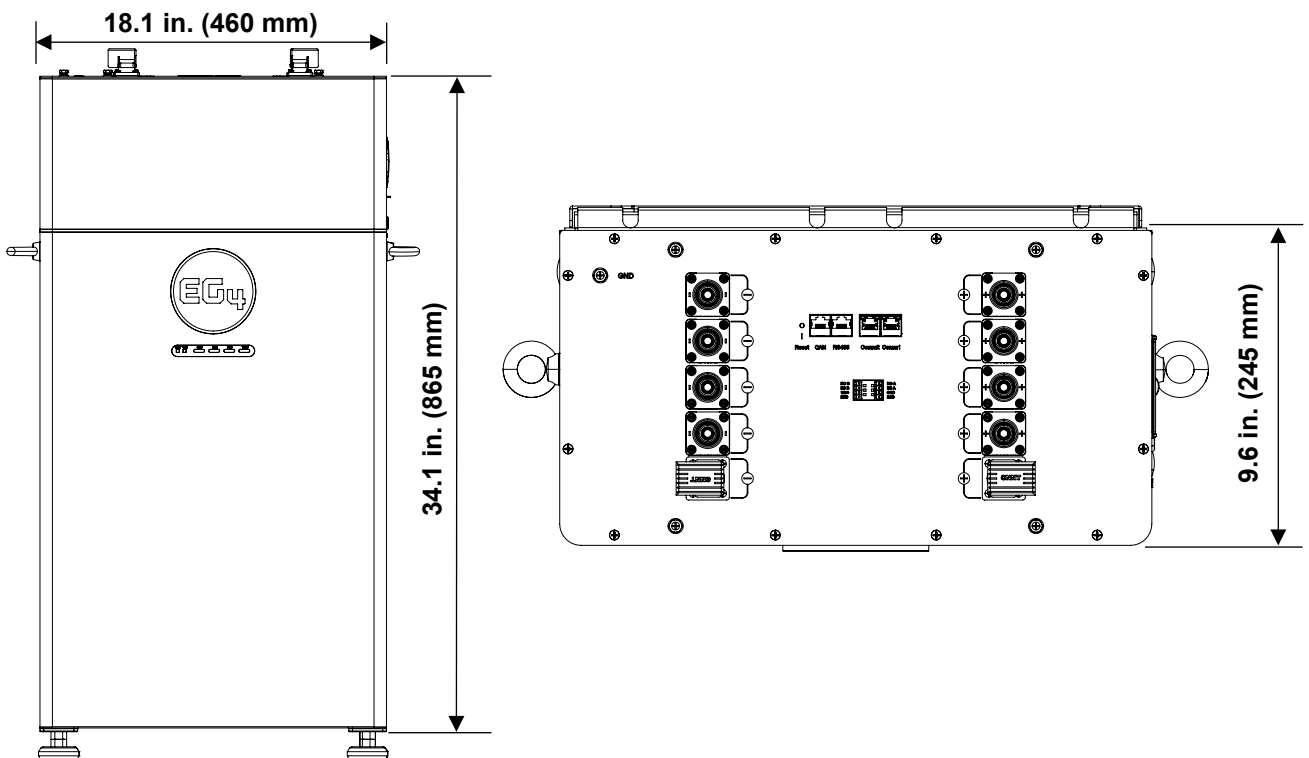

6.2 PACKING LIST

The following items are included with the product shipment:

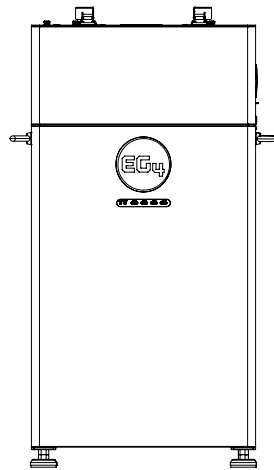

EG4 WallMount 314Ah Indoor Battery (x1)

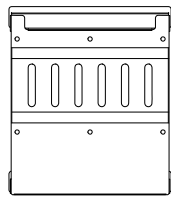

Mounting Bracket (x1)
(Will come attached to the back of the battery)

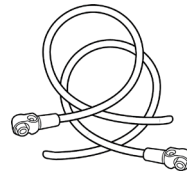

Red and Black Degson power cables (2 set each)
2/0 AWG (39.4 in.)



M10 Lifting Eye Bolt (x2)

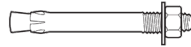

Expansion Bolt (x6)
M8*70



Battery to Inverter Communication Cable (x1)
(59.1 in.)

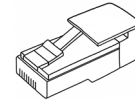

120Ω Terminating Resistor

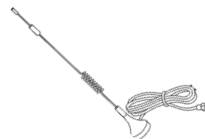

Wi-Fi/Bluetooth Antenna

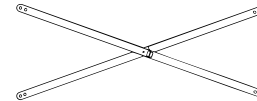

X-Bracket



DANGER:

Before installing or removing the battery, confirm that the battery is powered off and use a multimeter to verify that no voltage is present. This prevents accidental contact with live terminals.

6.3 BMS OVERVIEW

The Battery Management System (BMS) protects the battery and its cells from operating conditions that could damage system components. It enforces a 157A charge limit and a 200A discharge limit, helping extend battery life and maximize the number of operating cycles. Each EG4® WallMount 314Ah Indoor Battery is precisely configured to deliver optimal performance and verify reliable operation within any supported system.

PCB TEMPERATURE PROTECTION

The Battery Management System (BMS) prevents the Printed Circuit Board (PCB) from overheating. The PCB houses the primary control electronics of the battery. If the BMS detects overheating, it automatically shuts down the battery to protect the system.

VOLTAGE PROTECTION

The Battery Management System (BMS) continuously monitors the voltage of each individual cell and prevents overcharging and undercharging.

ACTIVE CELL BALANCE PROTECTION

Cell balancing maintains each individual cell within a specific voltage range relative to the others. This automatic process optimizes battery performance and extends service life without requiring any manual intervention.

ENVIRONMENTAL TEMPERATURE PROTECTION

Operating the battery outside the environmental parameters specified on the spec sheet can be dangerous and may cause permanent damage to the battery module and its components. To prevent damage, the Battery Management System (BMS) continuously monitors temperature during charging and discharging and automatically shuts down the battery when temperatures exceed safe limits. Refer to Section 1 for the approved battery charging and discharging temperature ranges.

CURRENT PROTECTION

The Battery Management System (BMS) continuously monitors charge and discharge current and includes built-in safeguards to prevent operation beyond specified limits. These safeguards include rapid shutdown timers for short circuits or extreme overcurrent conditions, as well as delayed shutdown protection when the current slightly exceeds the maximum rated capacity.

6.4 STORAGE INFORMATION

Follow these steps to store batteries safely and prevent damage during storage.

BATTERY STATE

The battery's State of Charge (SOC) at the time of storage affects how long it retains its charge. EG4® recommends adjusting each battery to a 20 – 50% SOC before placing it into storage. Lithium batteries naturally lose a portion of their total charge during storage, depending on the storage duration and environmental conditions. For optimal performance, EG4 recommends charging or discharging the batteries every three months.

ENVIRONMENTAL FACTORS

The battery storage location significantly affects battery health. For best results, maintain the storage temperature between 32°F – 113°F (0°C – 45°C) for storage periods of up to three months. For storage longer than three months, maintain the temperature within the recommended range of 59°F – 86°F (15°C – 30°C).

If the cell storage period exceeds six months, adjust the cell's State of Charge (SOC) to 20 – 50% through a controlled charge and discharge process. Maintain the storage environment at a relative humidity of 90% RH or lower and within a temperature range of 41°F – 77°F (5°C – 25°C).

Keep the battery away from areas where it may be exposed to moisture or high humidity (≥90% RH).
Store batteries away from combustible materials!

6.5 BATTERY PERFORMANCE CURVES

Charge & Discharge curve with 0.5C @ 25°C

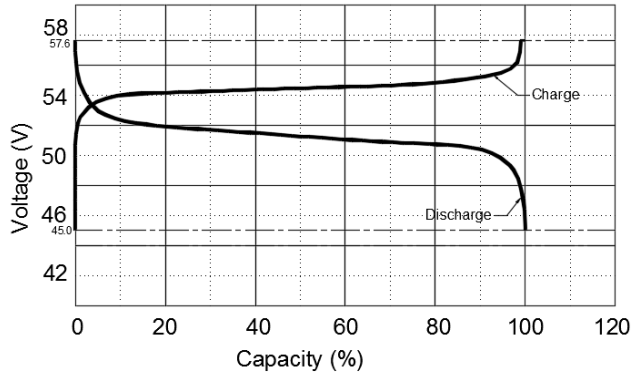

Discharge performance with different rate @ 25°C

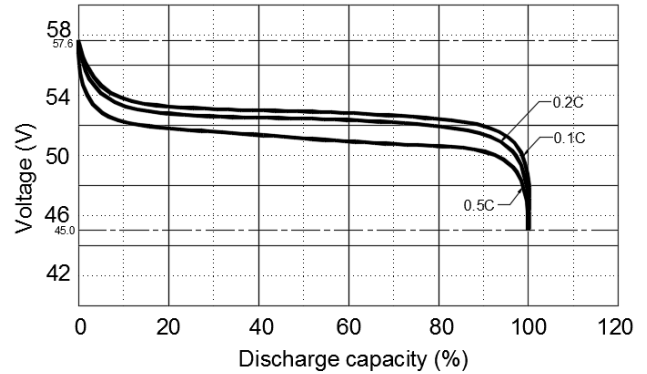

Discharge capacity with different temperature @ 0.5C

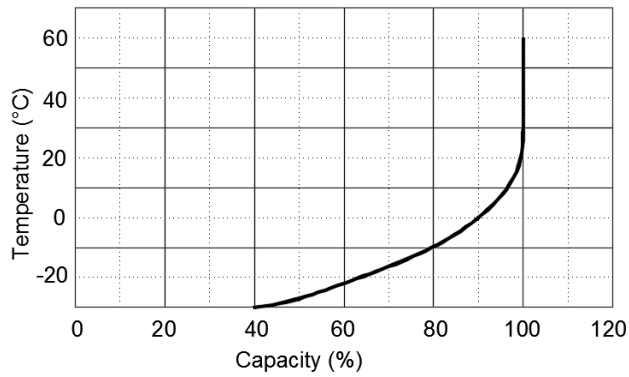

Cycle life with DOD @ 0.5C, 25°C

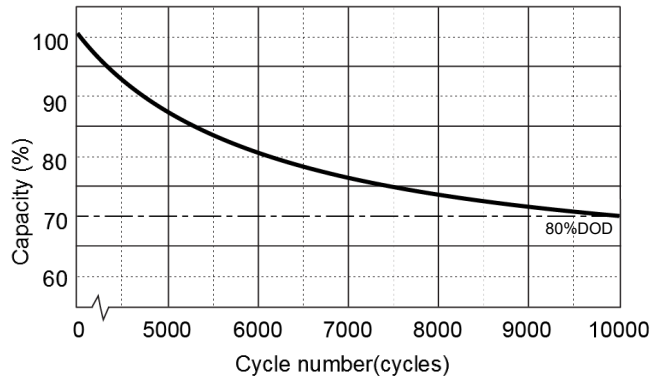

Self-discharge @ different temperature

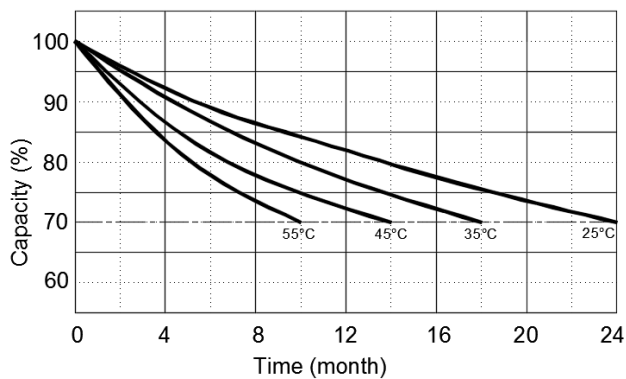

6.6 BATTERY CHARGING

Confirm that the charge controller and/or inverter uses the correct settings to prevent overcharging or damage to the module. (Refer to Section 1: Technical Specifications, for the complete list of charging and discharging parameters).

EG4® WallMount 314Ah Indoor batteries with individual BMS units and connected in parallel may display a wide range of State of Charge (SOC) readings during charge or discharge cycles. SOC variations of up to 10% are normal. For additional information on Battery State of Health (SOH) and Depth of Discharge (DoD), scan the QR code below:



This condition does not indicate a fault or reduced module capacity. Minor differences in wiring resistance, internal resistance, temperature, or individual cell characteristics can cause temporary SOC variations. Even small differences may cause one battery to momentarily carry more load or accept more charge. Over the course of a full charge or discharge cycle, these differences balance out as the lagging battery compensates later in the cycle, allowing the system to recover the full rated kWh capacity of the battery pack. Voltage differences that develop as SOC levels diverge will ultimately drive the batteries to converge at another point in the cycle.



NOTE:

When installing multiple batteries or adding a battery to an existing bank, verify that all batteries are charged to 100% before connecting them in parallel. This step is crucial to optimizing battery performance.

6.7 FRONT PANEL INDICATOR LIGHTS

The WallMount 314Ah Indoor Battery includes two status indicator LEDs and four State of Charge (SOC) indicator LEDs on the front panel. Their functions are described below:



1. **ALM** – The ALM indicator illuminates solid red when a fault occurs. Refer to Section 13 for detailed information on specific faults and the required corrective actions.
2. **Run** – The RUN indicator illuminates solid green when the battery is idle. When the battery is charging or discharging, the indicator flashes green.
3. **25%/50%/75%/100%** – The SOC indicator LEDs display the battery charge level in 25% increments. A red 25% LED indicates an SOC of 0 – 15%, while a green 25% LED indicates 16 – 25%. A green 50% LED, with all preceding LEDs illuminated green, indicates 26 – 50% SOC. A green 75% LED, with all preceding LEDs illuminated green, indicates 51 – 75% SOC. A green 100% LED, with all preceding LEDs illuminated green, indicates 76 – 100% SOC.



NOTE:

See section 13.1 for full LED indicator status and definition.

7. GENERAL INSTALLATION

This section outlines the detailed steps required to install and configure the battery. Complete each section in the order listed below:

INSTALLATION STEPS

- 7.1 Recommended Tools
- 7.2 Location Requirements
- 7.3 Battery Installation
- 7.4 Battery and Conduit Box
- 7.5 Battery and Conduit Box with EG4 18kPV
- 7.6 Battery and Conduit Box with EG4 12kPV/FlexBOSS18/21

7.1 RECOMMENDED TOOLS



Safety Goggles



Dielectric Shoes



Gloves



Multimeter



Phillips Head
Screwdriver



Socket Set



Electric Drill and
Drill Bits



Flathead
Screwdriver

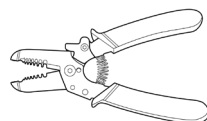

Wire Stripper



Level

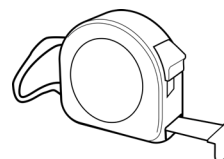

Tape Measure

7.2 LOCATION REQUIREMENTS

Requirements for installation location:

- The EG4® WallMount 314Ah Indoor Battery is heavy. Use an equipment lift or a team-lift technique when moving the battery.
- The battery is designed for indoor installation only. Install residential units only in attached or detached garages, sheds, enclosed utility closets, basements, storage areas, or utility spaces within dwelling units. Do not install units in habitable or living spaces. Additionally, units are not intended for installation near marine environments.
- Users may install the battery against a flat wall; however, do not allow the wall to support the full weight of the battery. Use the pre-installed feet to transfer part of the battery's weight to the floor.
- When installing the battery on flat ground, confirm proper drainage around the installation area to prevent potential damage from flooding.
- Based on UL 9540A testing, the manufacturer recommends a minimum spacing of 4 in. between WallMount 314Ah Indoor batteries (see Intertek/ETL Test Report 251120146GZC-001). Consult the Authority Having Jurisdiction (AHJ) before installation to determine whether reduced spacing is permitted. If reduced spacing is not approved, follow all applicable state and local building and/or fire code spacing requirements.
- Verify that the installation location maintains a minimum clearance of 23.6 in. (600 mm) from all exposures and egress points.
- Verify that the battery is installed in an upright position.
- Consult applicable state and local building, fire, and installation codes to determine smoke alarm requirements.



IMPORTANT:

Verify that a minimum installation space volume of 50 m³ is required if not ventilated. This ensures flammable gas stays below 25% of the Lower Flammable Limit (LFL) in case of thermal runaway. Room volume is based on released gases and the number of battery cells affected during testing. Adding more EG4® WallMount 314Ah Indoor batteries does not require a larger installation location, as tests showed no propagation between units. Required installation volume may be reduced with proper ventilation per code and jurisdictional requirements.



NOTE:

The battery is very heavy. Use the team-lift technique during installation.



WARNING:

Do not make any electrical connections until the battery is in its final location.

7.3 BATTERY INSTALLATION



NOTE:

When using an equipment lift to move the battery, attach the M10 lifting eye bolts to both sides of the battery.

1. Remove the four set screws that secure the mounting bracket to the back of the battery and set them aside.
2. Remove the mounting bracket from the battery and set it to the side.

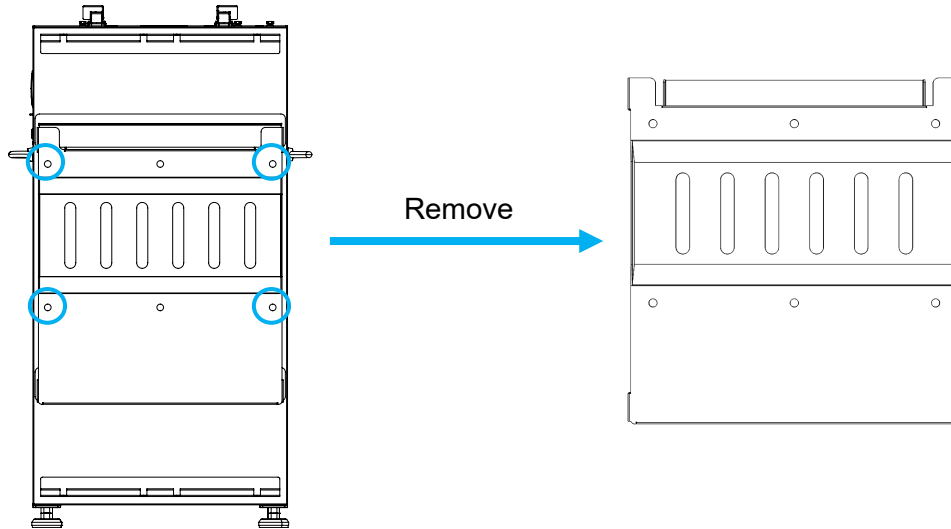

3. Position the top of the mounting bracket on the wall at the desired mounting height, ensuring a minimum ground clearance of 29 in. (736.6 mm).

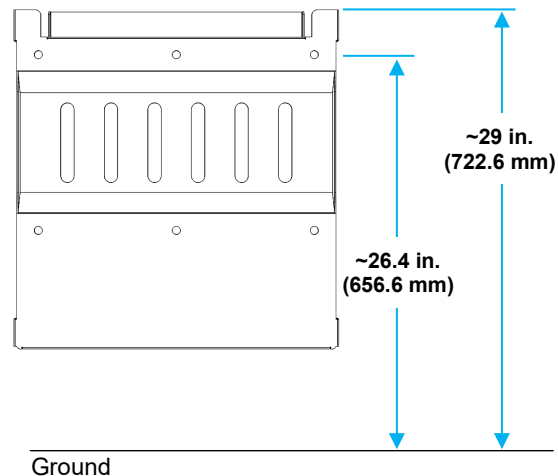

4. Use a level to verify that the bracket is level with the ground, then drill six holes to accommodate the mounting hardware.

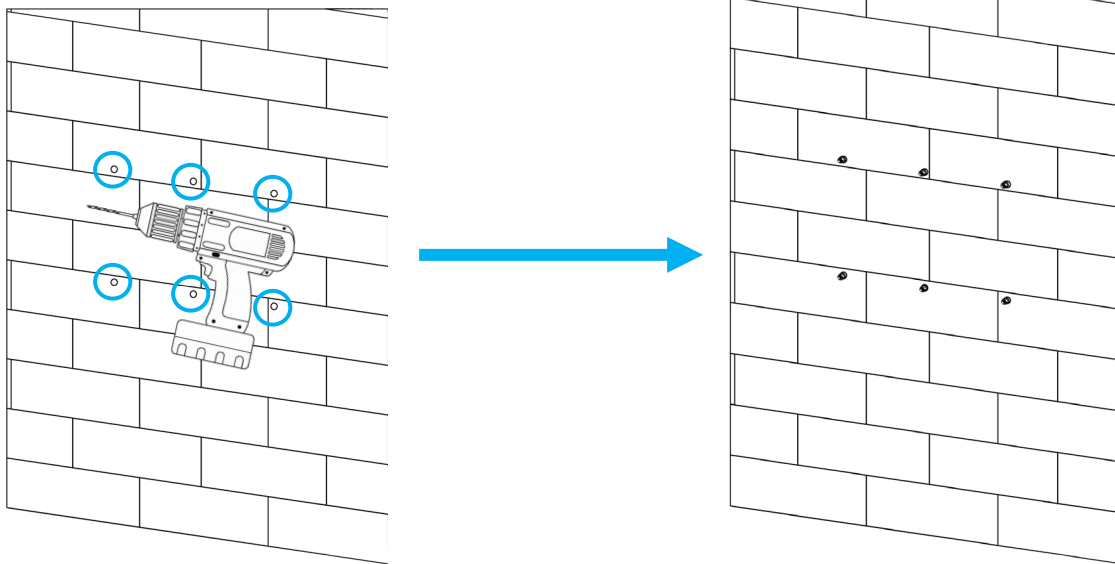

5. Secure the mounting bracket to the wall using hardware appropriate for the mounting surface. Use the included expansion bolts when mounting to concrete or brick.

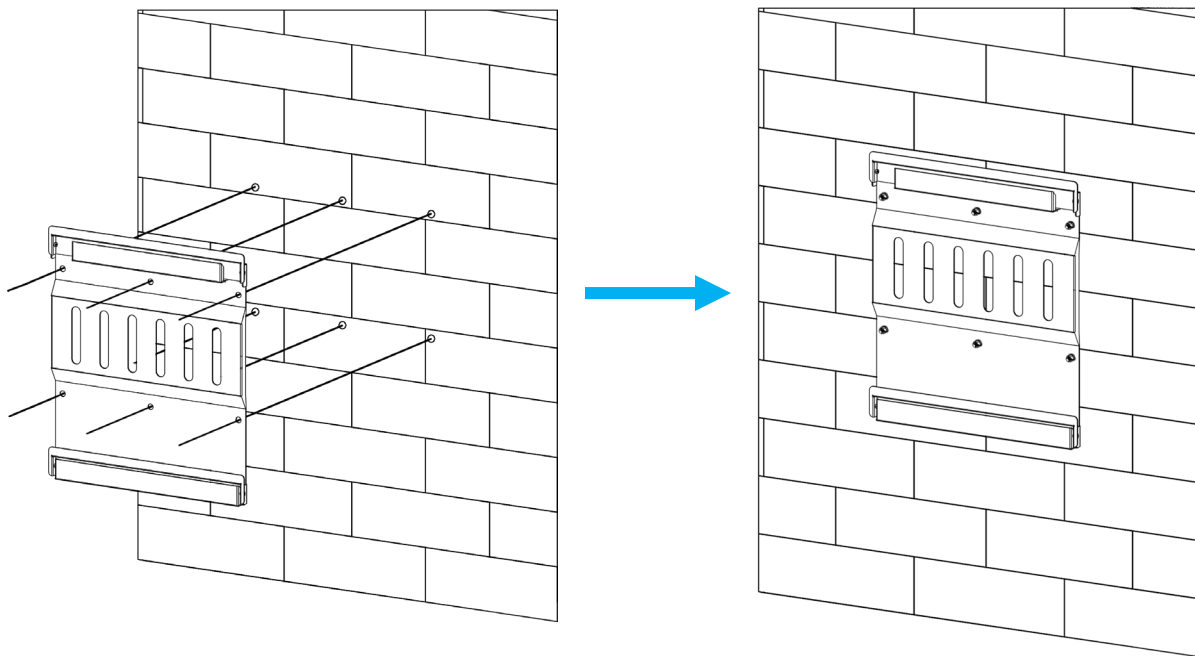

6. Attach the battery to the mounting bracket. Using a team-lift technique, lift the battery and hook the rear flange of the battery onto the front flange of the mounting bracket.

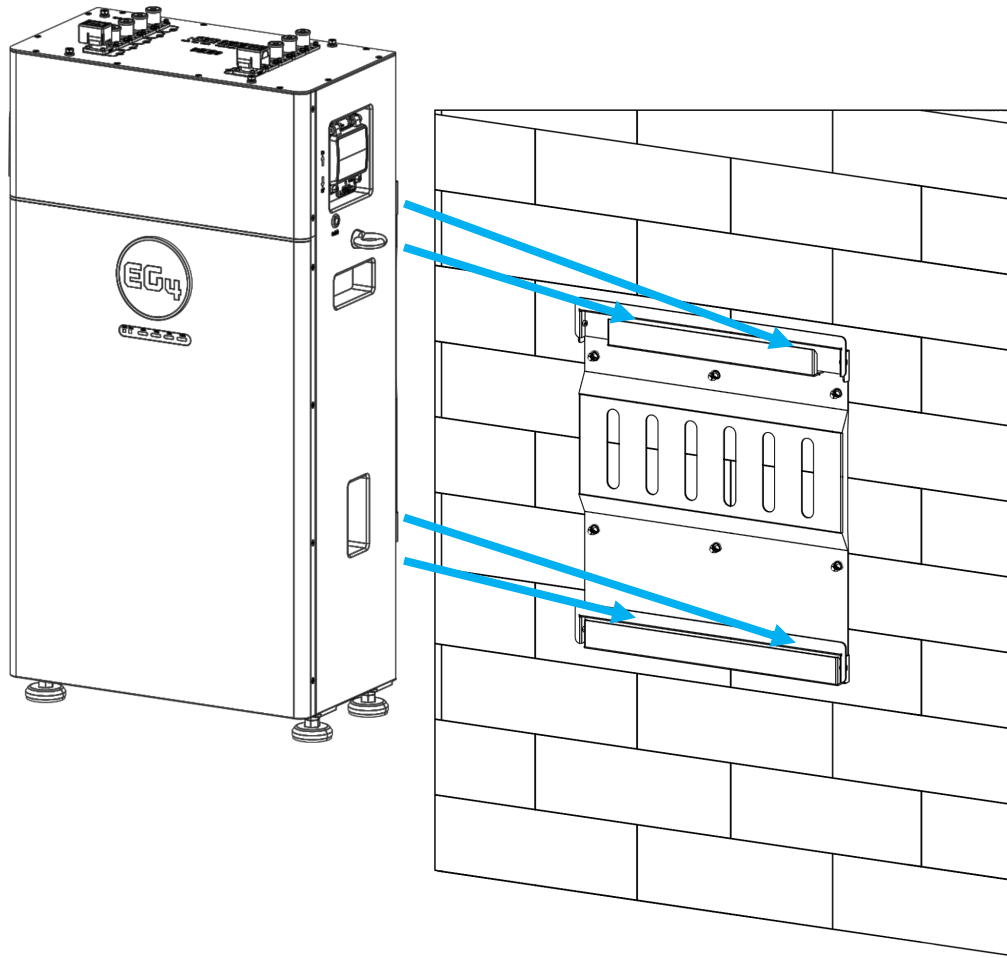

7. Secure the battery to the mounting bracket using the four included side screws from Step 1.

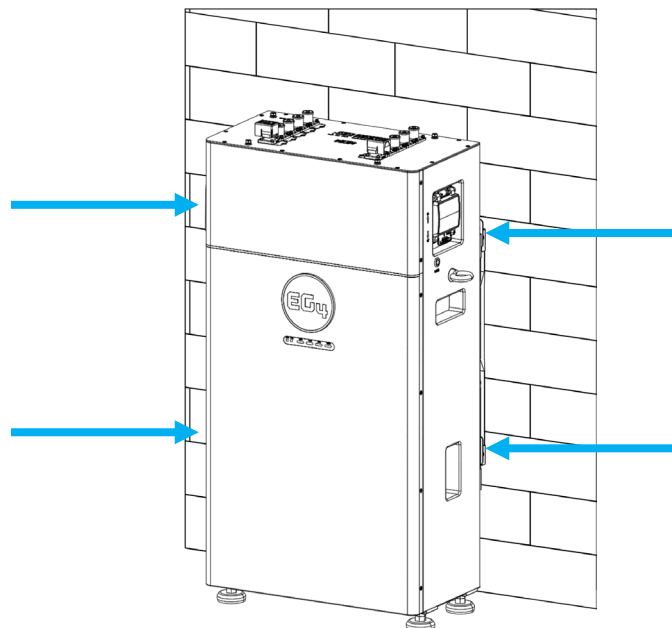

8. After securing the battery, attach the Wi-Fi/Bluetooth antenna to the left side of the battery.

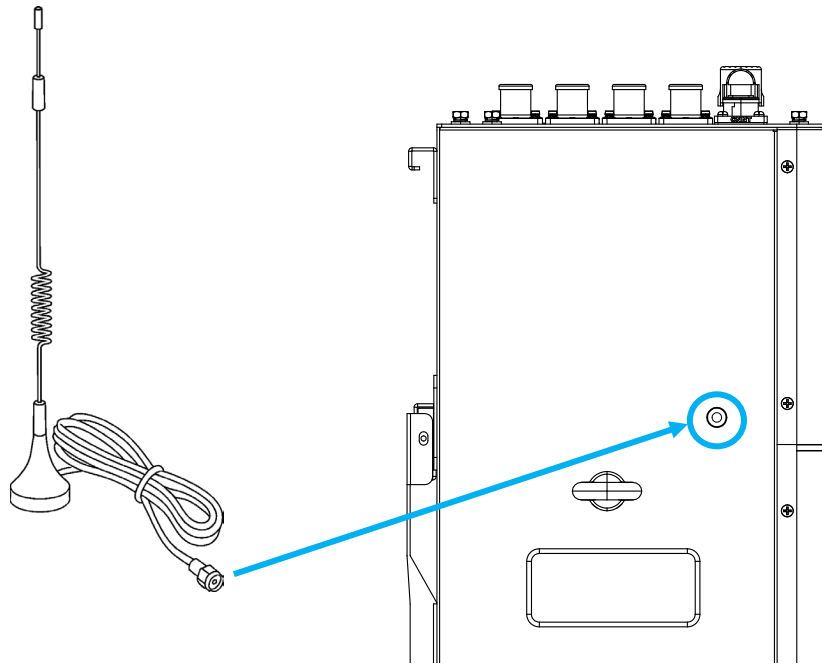

7.4 BATTERY WITH CONDUIT BOX

When installing the battery with the optional Indoor Buildable Conduit Box, continue with the steps below, starting from Step 8 of the previous section. Maintain a clearance of 4 in. (101.6 mm) on both sides of the battery. Do not install the front cover of the conduit box until the assembly is complete.

1. Remove the four screws on the top of the battery as shown in the image below, and retain them for use in step 2.

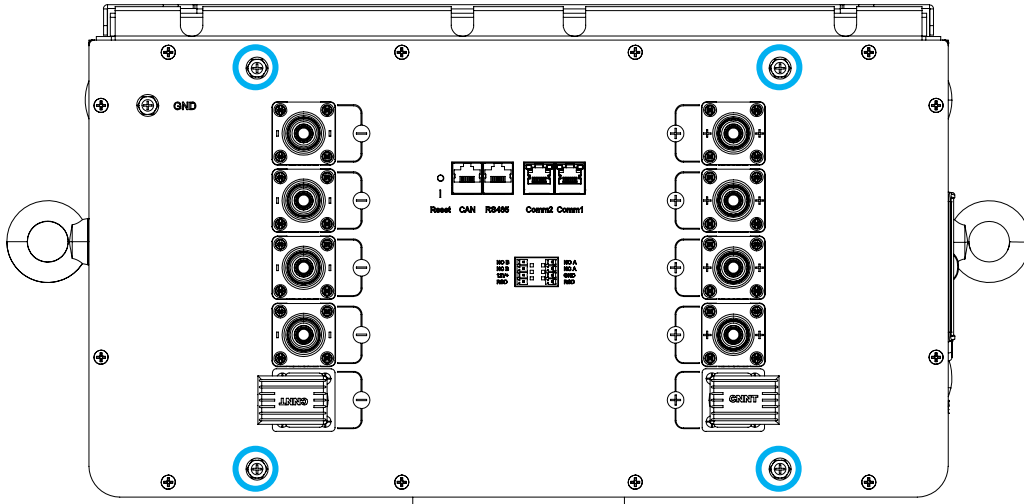

NOTE:

Refer to the EG4® Indoor Buildable Conduit Box quick start guide at www.eg4electronics.com for assembly instructions or scan the QR code below.



2. Identify the four screw locations on the bottom of the Indoor Buildable conduit box that line up with the screw holes on top of the WallMount 314Ah Indoor battery. Place the conduit box on top of the battery and use the screws from step 1 to attach the box to the top of the battery.

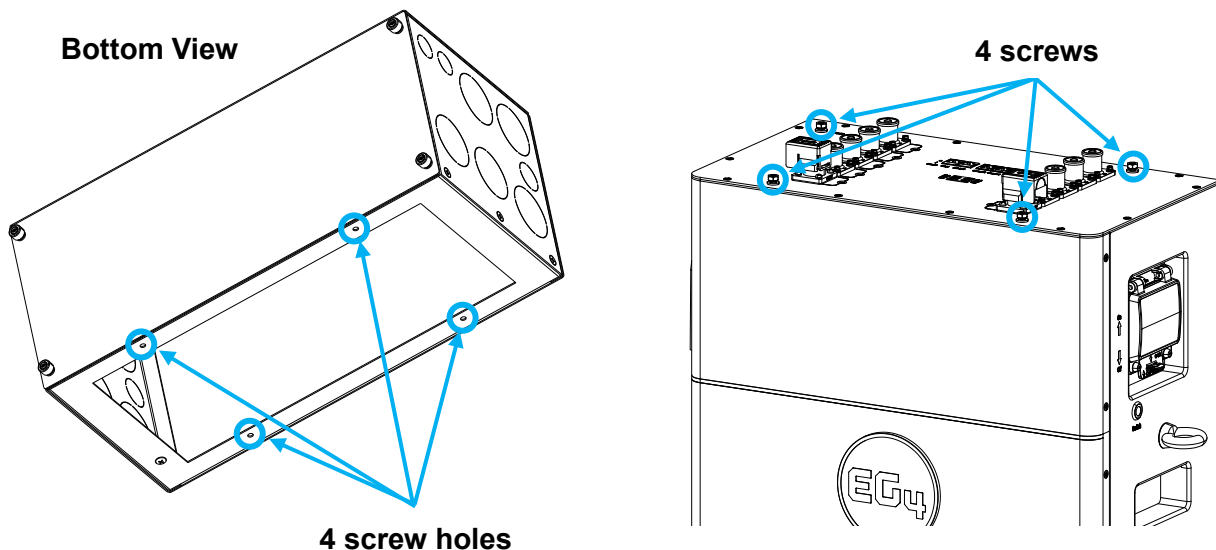

3. Finally, attach the grounding conductor to the M6 grounding screw on top of the battery to the Equipment Grounding System to properly ground the battery.

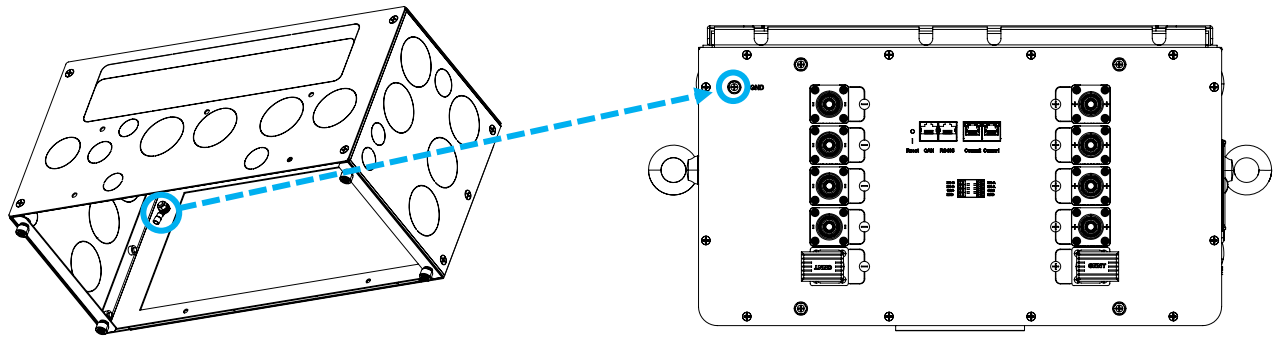

The image below represents a complete install:

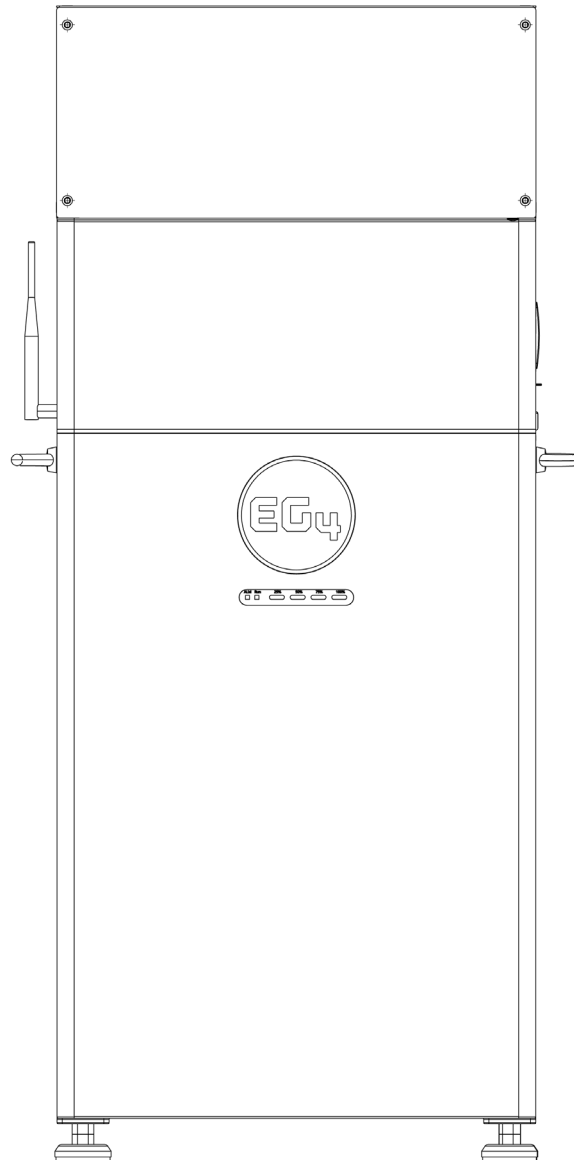

7.5 BATTERY, CONDUIT BOX, & 18KPV

After completing Step 3 in Section 7.4, follow the instructions below to install the system with an 18kPV inverter and the Indoor Buildable Conduit Box:

1. Align the included X-bracket with the drilled holes and mount both the battery bracket and the X-bracket to the wall, positioning the X-bracket against the wall.
2. Use the uppermost hole on the X-bracket to attach the inverter mounting bracket with hardware appropriate for the mounting surface. Refer to the inverter user manual for additional details.
3. Attach the battery to the mounting bracket. Use a team-lift technique to secure the battery onto the bracket's flanges.
4. Attach the conduit box to the battery. Refer to Section 7.4 for detailed installation instructions.
5. Install the 18kPV inverter onto the inverter mounting bracket (included with the inverter), ensuring that the inverter mounting holes align with the conduit box. Secure the inverter and conduit box together using the included hardware.
6. Properly ground the battery by connecting the grounding conductor from the conduit box to the M6 grounding screw on the top of the battery.

Images are for representative purposes only.

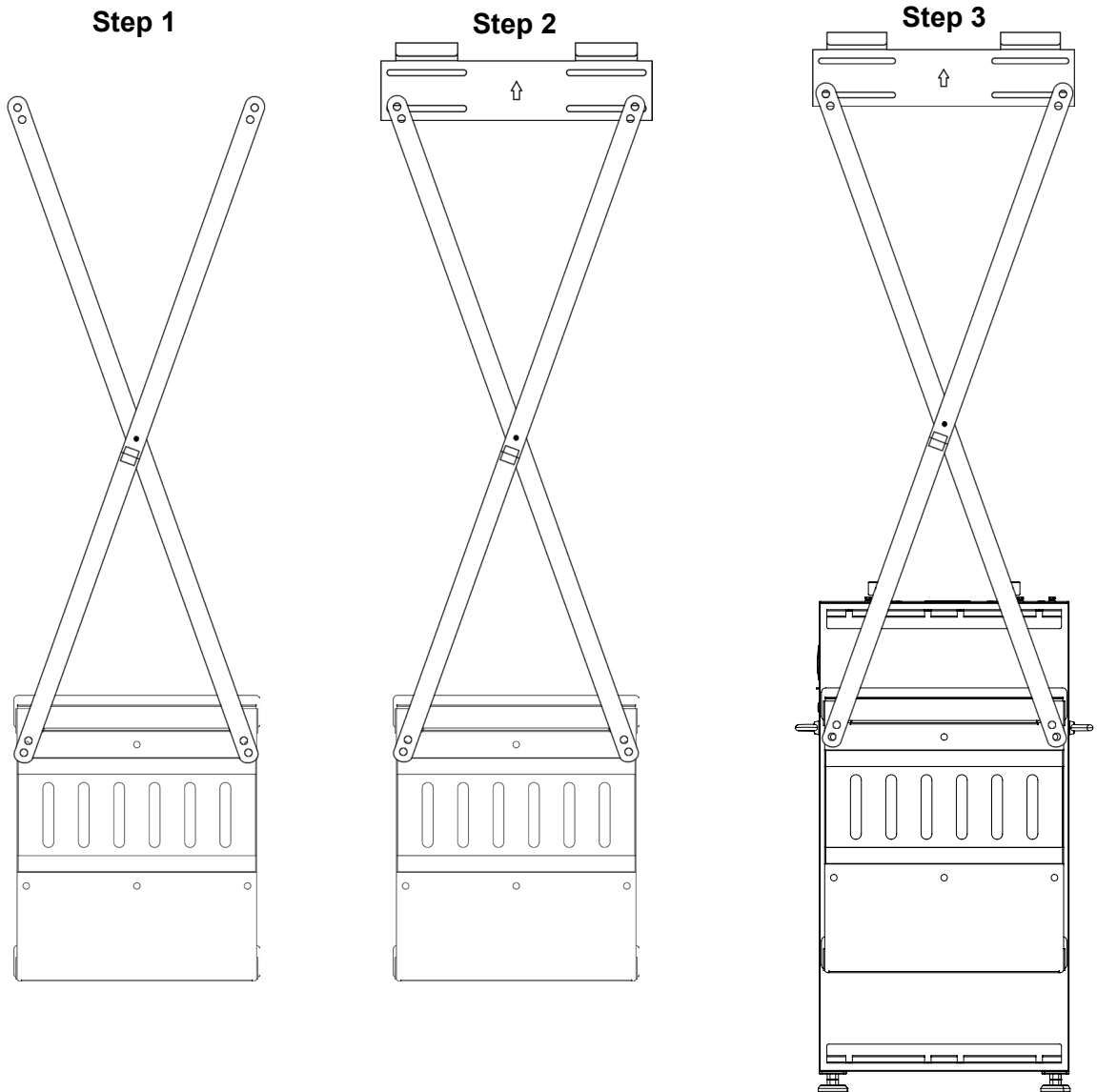

Images for representative purposes only.

Step 4

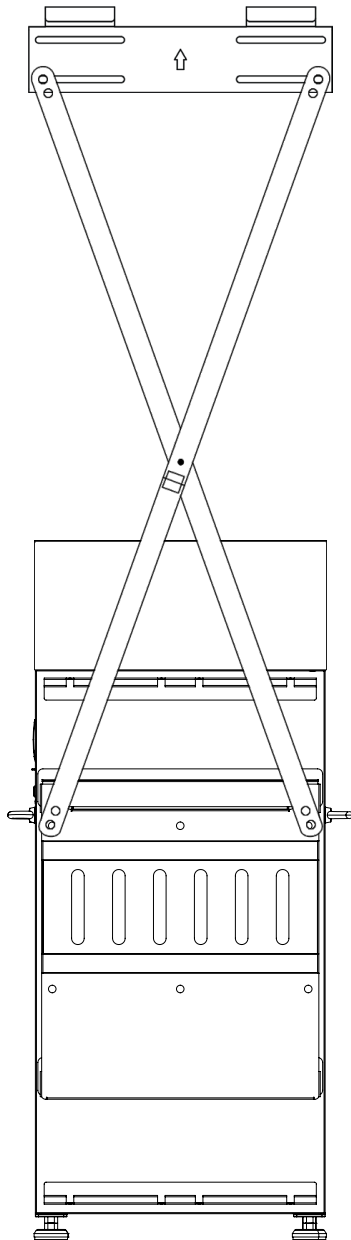

Step 5

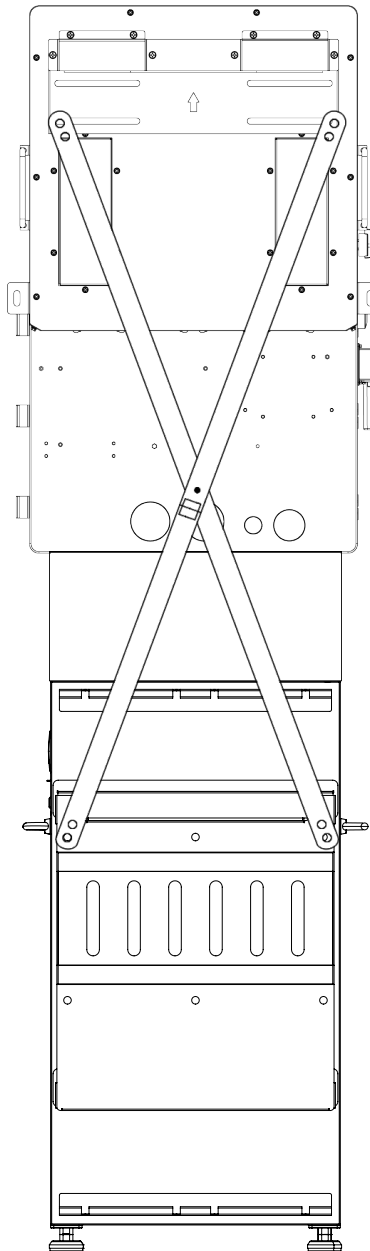

7.6 BATTERY, CONDUIT BOX, & 12KPV/FLEXBOSS18/21

After completing Step 3 in Section 7.4, follow the instructions below to install the system with a 12kPV, FlexBOSS18, or FlexBOSS21 inverter and the Indoor Buildable Conduit Box:

1. Align the included X-bracket with the drilled holes and mount both the battery bracket and the X-bracket to the wall, positioning the X-bracket against the wall.
2. Use the lowermost hole on the X-bracket to attach the inverter mounting bracket with hardware appropriate for the mounting surface. Refer to the inverter user manual for additional information.
3. Attach the battery to the mounting bracket. Use a team-lift technique to secure the battery onto the bracket's flanges.
4. Attach the conduit box to the battery. Refer to Section 7.4 for detailed installation instructions.
5. Install the applicable inverter onto the inverter mounting bracket (included with the inverter), ensuring that the inverter mounting holes align with the conduit box. Secure the inverter and conduit box together using the included hardware.
6. Properly ground the battery by connecting the grounding conductor from the conduit box to the M6 grounding screw on top of the battery.

Images are for representative purposes only.

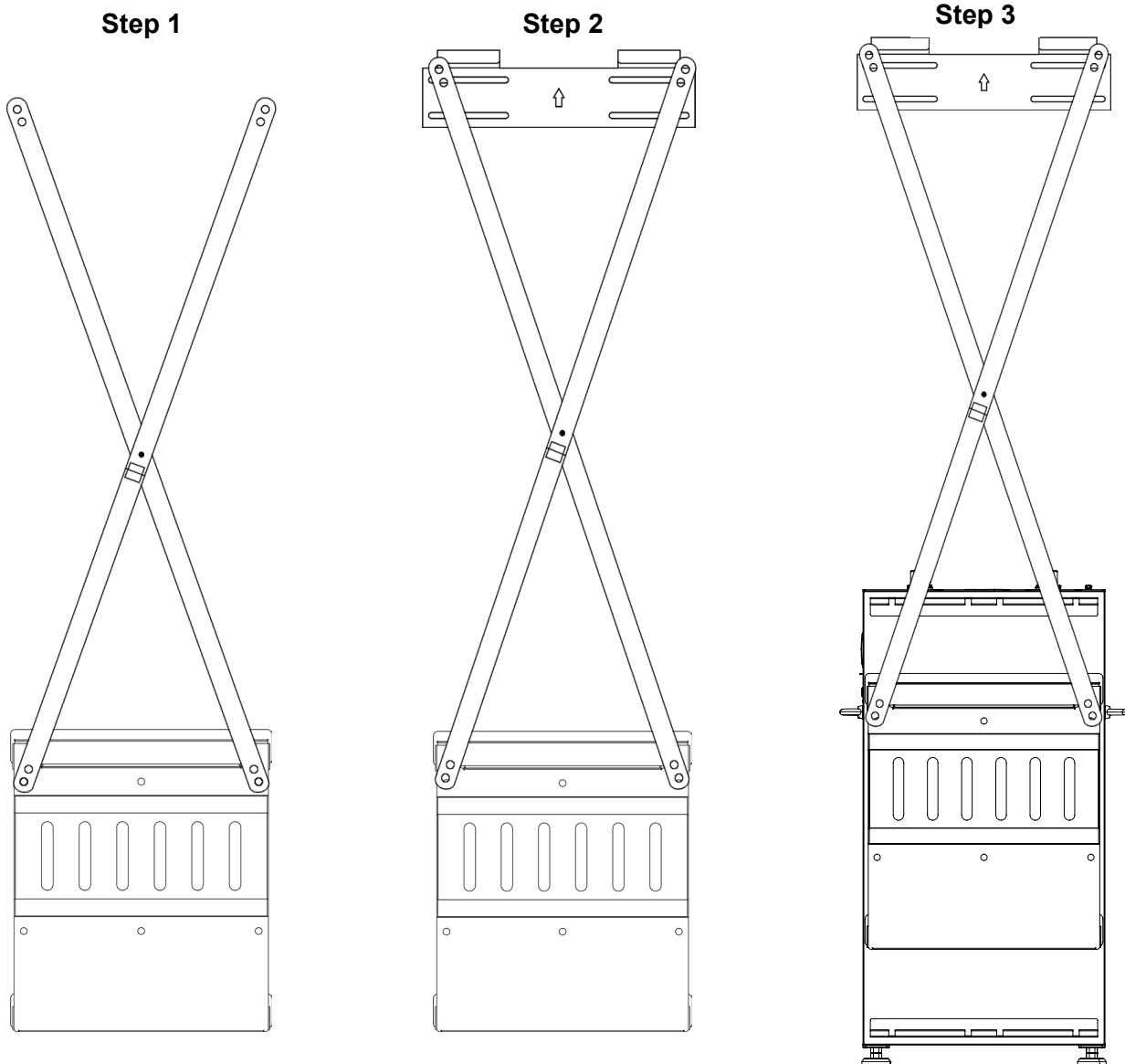

Images are for representative purposes only.

Step 4

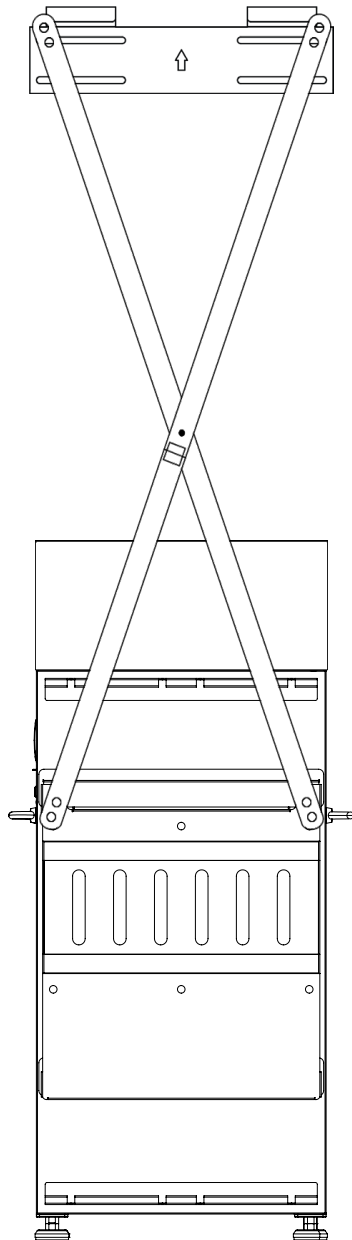

Step 5

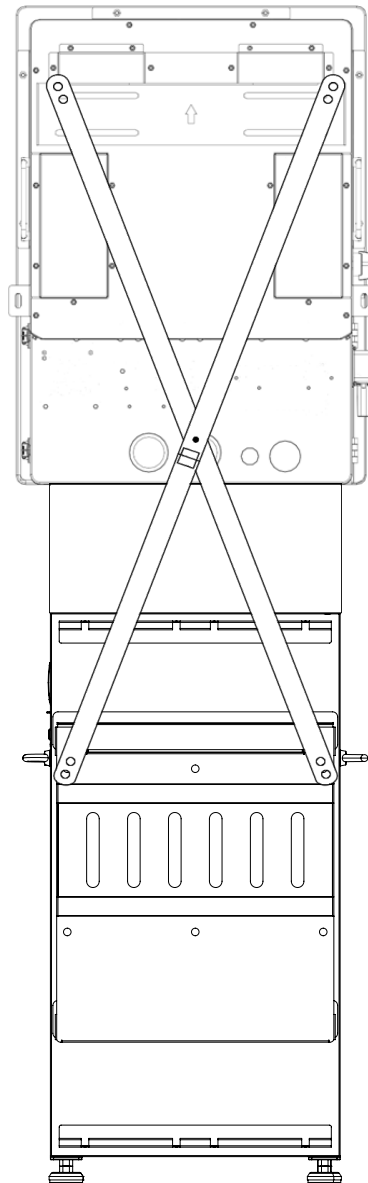

8. CONNECTING MULTIPLE BATTERIES IN PARALLEL

When connecting multiple EG4® WallMount 314Ah Indoor batteries in parallel, use a paralleling kit, which the manufacturer recommends purchasing through an authorized distributor. Use the battery-to-battery communication cable included in the paralleling kit to connect and parallel the batteries.



IMPORTANT:

The battery supports charging currents up to 157A and discharging currents up to 200A before the BMS shuts down the battery. Confirm that the inverter is properly configured to operate within these charge and discharge limits. If custom battery power cables are required, refer to an NEC-approved ampacity chart.

8.1 BMS COMMUNICATION WIRING

The diagram below illustrates the battery communication cable wiring when using the Auto-ID BMS protocol exclusively.

Follow the guidelines listed below:

1. Starting with the last battery in the stack, use the included communication cables to connect the batteries in parallel. Plug the cable into the Comm 1 port on the last battery, then daisy-chain to the Comm 2 port on the next battery. Repeat this process until one reaches the master battery.
2. Depending on whether the system uses CAN or RS485 communication, connect the battery-to-inverter communication cable to the corresponding CAN or RS485 port on the master battery. Then connect the other end of the cable to the matching battery communication port on the inverter.
3. Install the included 120Ω terminating resistor into the “Comm 1” port on the master battery to “close” the communication loop.
4. Install a second 120Ω terminating resistor into the “Comm 2” port on the last battery in the stack to “close” the communication loop.



NOTE:

When using closed-loop communication, connect the 120Ω terminating resistor to the Comm 1 port on the master battery. Verify that the resistor is installed in the correct port. Installing the resistor in the wrong port may damage the system and connected components.

For additional examples of battery paralleling configurations, refer to the example diagrams on the following page.

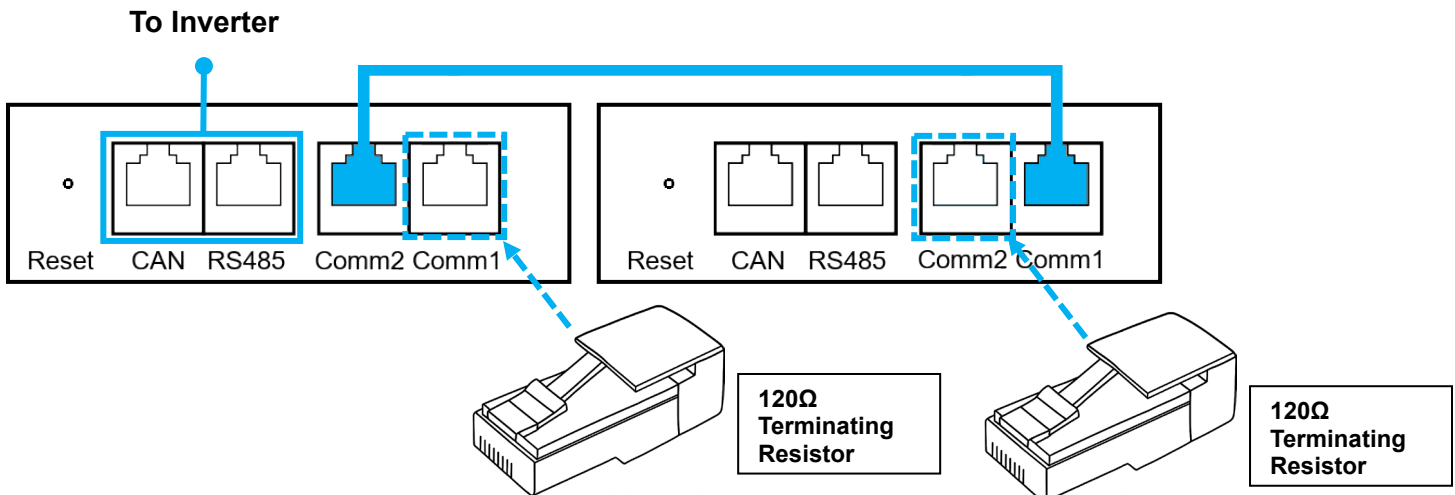



WARNING:

Do not connect EG4® batteries in series. The BMS and internal components are not designed for series configurations, and doing so may cause module failure and equipment damage.



NOTE:

The master battery will communicate directly with the system via the CAN/RS485 port.

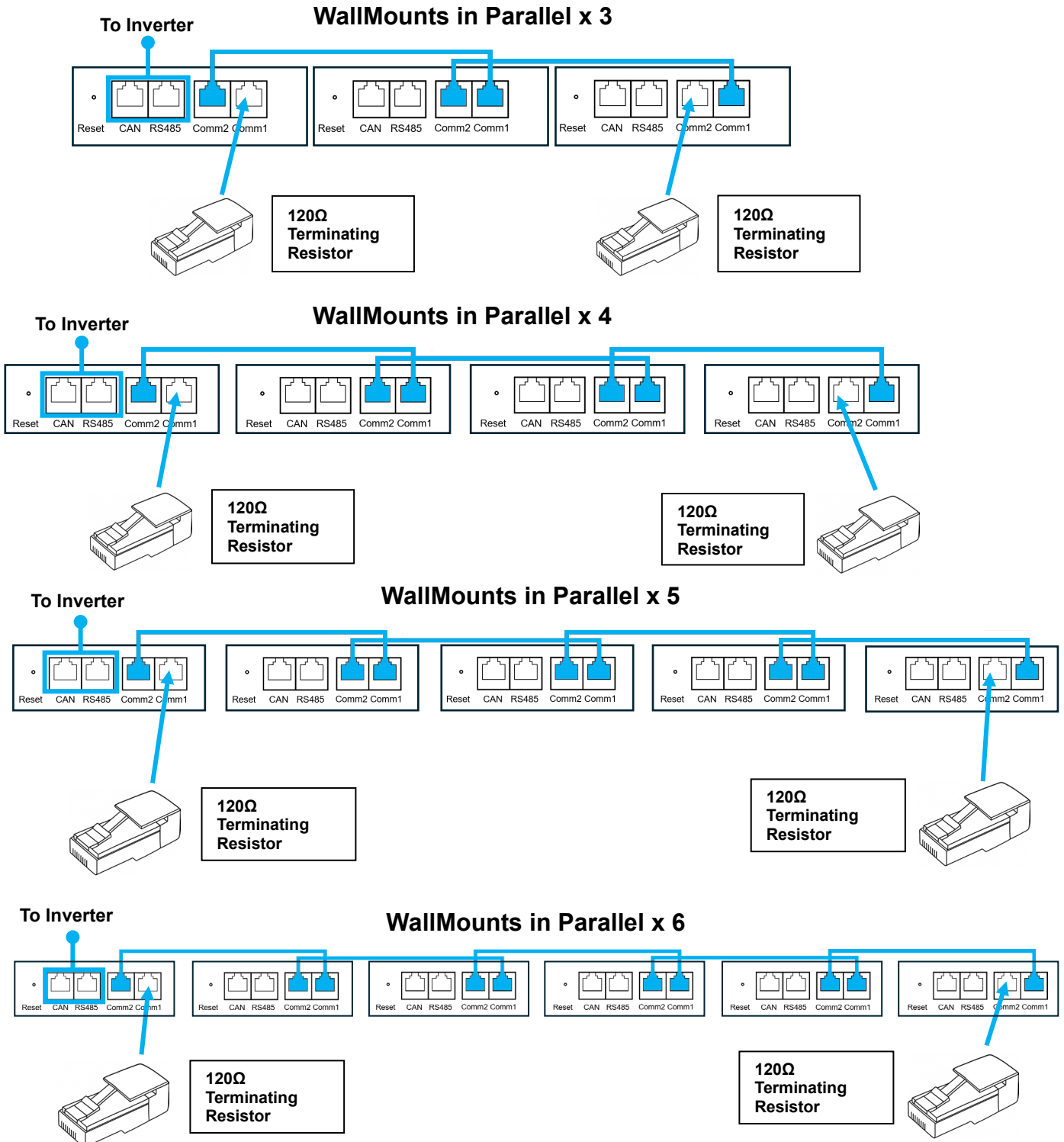

8.2 BATTERY CABLE CONNECTIONS

The following battery cable connection diagrams illustrate how to use the internal busbars to connect batteries in parallel and connect the inverter(s) to the batteries. When using the internal busbars, the system supports up to six batteries in parallel, whether connected to one, two, or three EG4® FlexBOSS21 inverters.

Systems that require more than six batteries in parallel must use an external fused positive busbar and an unfused negative busbar, each rated for a minimum of 200 A per battery. Use fuses rated at a maximum of 250 A. Alternatively, larger systems may use the FlexBOSS21 inverter’s ability to draw from separate battery packs while still paralleling inverters, instead of relying solely on common external busbars.



NOTE:

In the following diagrams, connect the inverter communication cable to the CAN/RS485 port on the FlexBOSS21 inverter, and space the units 4 in. (101.6 mm) apart. Local regulations may require greater minimum spacing between batteries; consult the local Authority Having Jurisdiction (AHJ) for specific requirements. If the installation requires parallel cables longer than those included in the optional paralleling kit, contact the distributor for availability.

Illustrations are for representative purposes only.

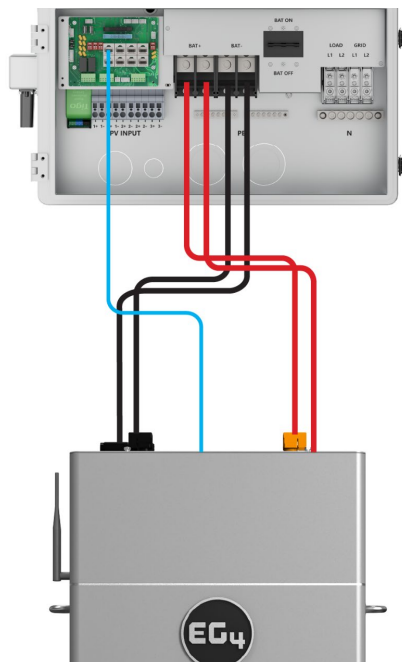

(1) FlexBOSS21 with (1) 314 Indoor



Note: To comply with the UL9540 listing for this integrated battery, conduit box, and inverter system, the batteries must be wired as shown on page 35 – 41 using the supplied inverter to battery cables. *An additional paralleling kit is required for each additional paralleled battery (sold separately).*



Caution: To minimize voltage drop in the wire, the battery cables should maintain optimum length. The 53.1 in. cables from the “parallel kit” are sufficient to daisy chain the batteries.

Color Code

- – Communication Cable
- – Positive Cable
- – Negative Cable



IMPORTANT:

To comply with UL 9540 safety standards, battery bank capacity is typically limited to a maximum of 20 kWh per bank or aggregate system limits of 40 kWh or 80 kWh, depending on the installation location. Some Authorities Having Jurisdiction (AHJs) may permit systems to exceed these limits based on UL 9540A large-scale fire testing data. The maximum supported number of batteries in a single battery bank is six.

Before purchasing or installing an energy storage system, verify that the system design complies with all applicable codes and requirements established by the local jurisdiction, fire department, and utility provider.

The manufacturer’s installation instructions do not override local codes or regulations. Code interpretation and enforcement may vary by jurisdiction. Early coordination with local officials can help save time and cost and reduce the risk of installation delays or compliance issues.

ADDITIONAL SINGLE INVERTER CONFIGURATIONS

Illustrations are for representative purposes only.

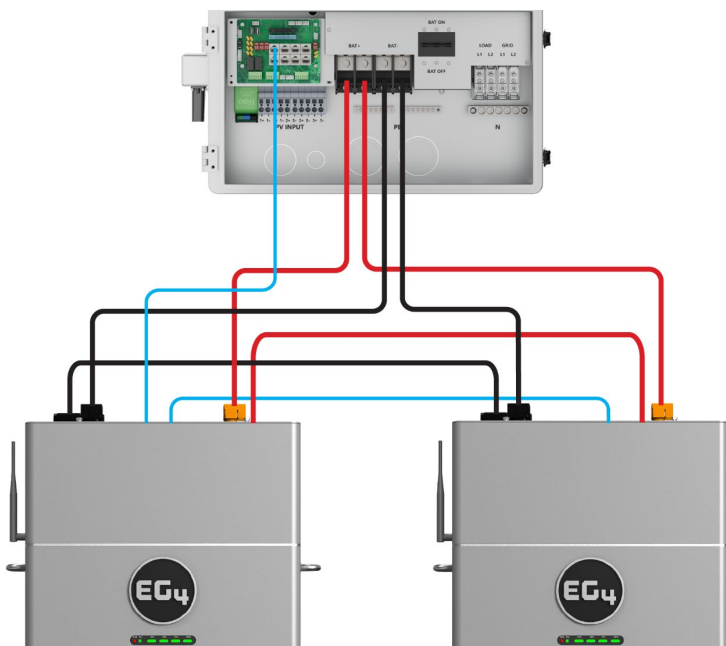

(1) FlexBOSS21 with (2) 314 Indoor



Note: Some configurations require additional wiring/connectors to achieve the example layouts. Inverter to inverter paralleling cables are not shown in the following diagram. Other configurations can be achieved by using external busbars. Contact an electrician or qualified personnel for optional system layout.



Reminder!
The separation between batteries should be ≥ 4 in.

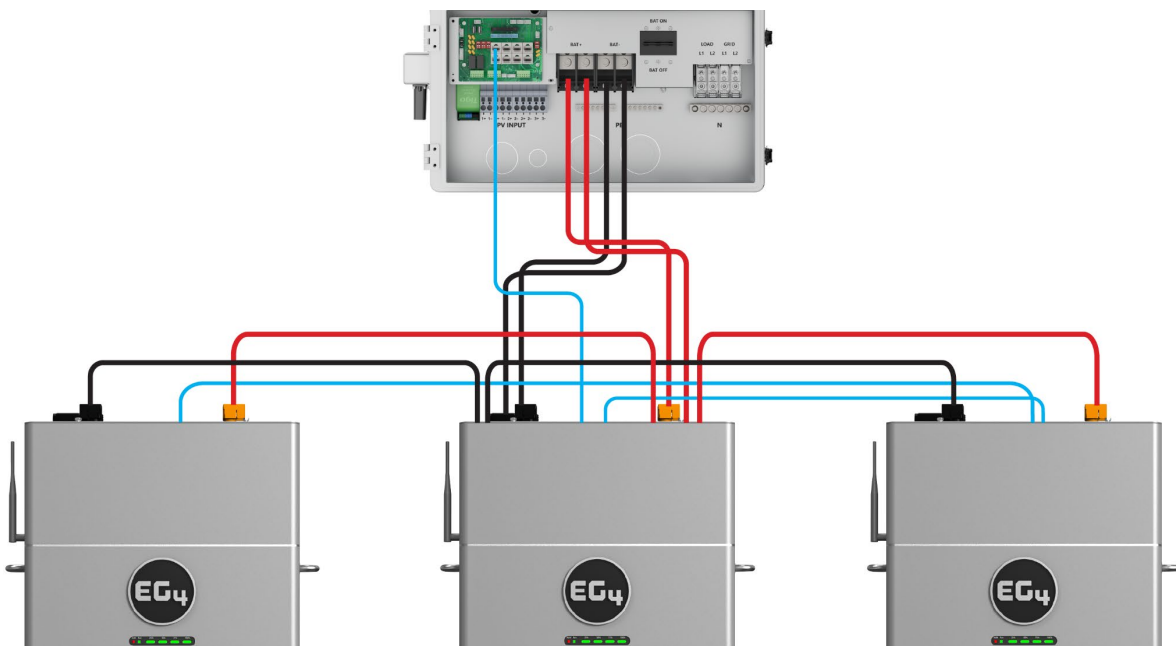

(1) FlexBOSS21 with (3) 314 Indoor



CAUTION:

When pairing the EG4® WallMount 314Ah Indoor battery with an inverter, do not exceed $>600A$ load on the master battery due to the internal busbar rating.

Illustrations are for representative purposes only.

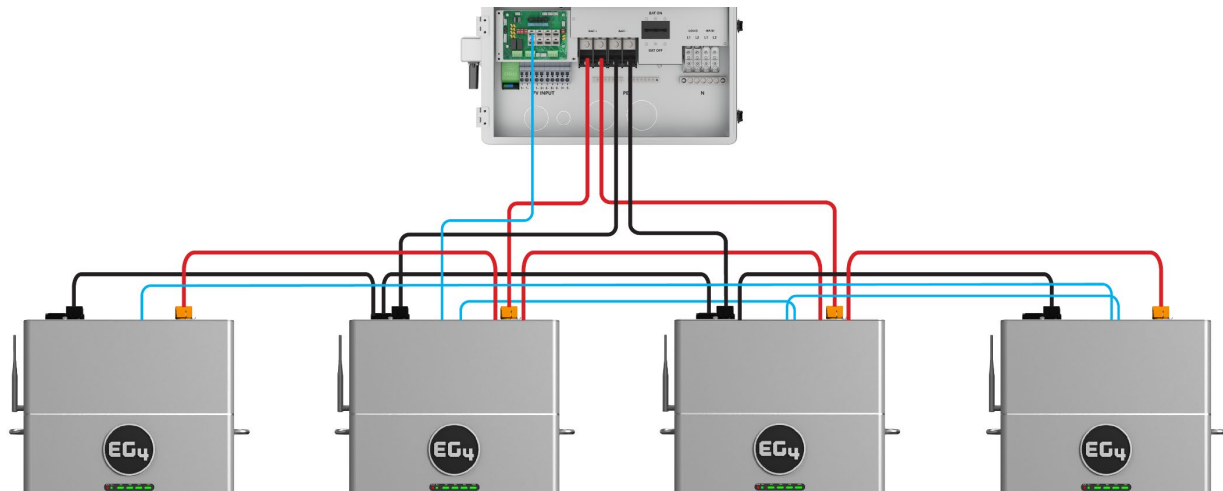

(1) FlexBOSS21 with (4) 314 Indoor

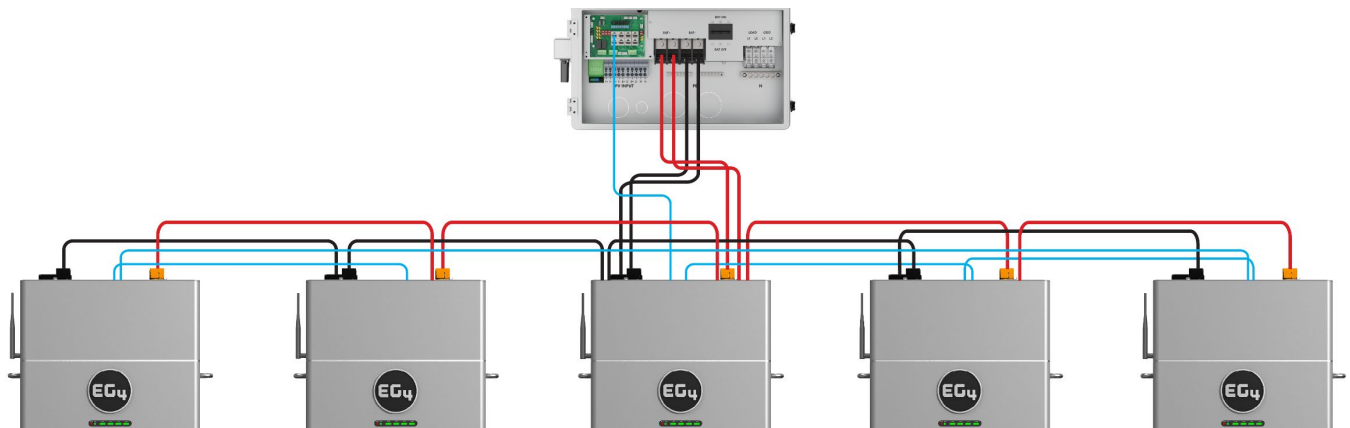

(1) FlexBOSS21 with (5) 314 Indoor

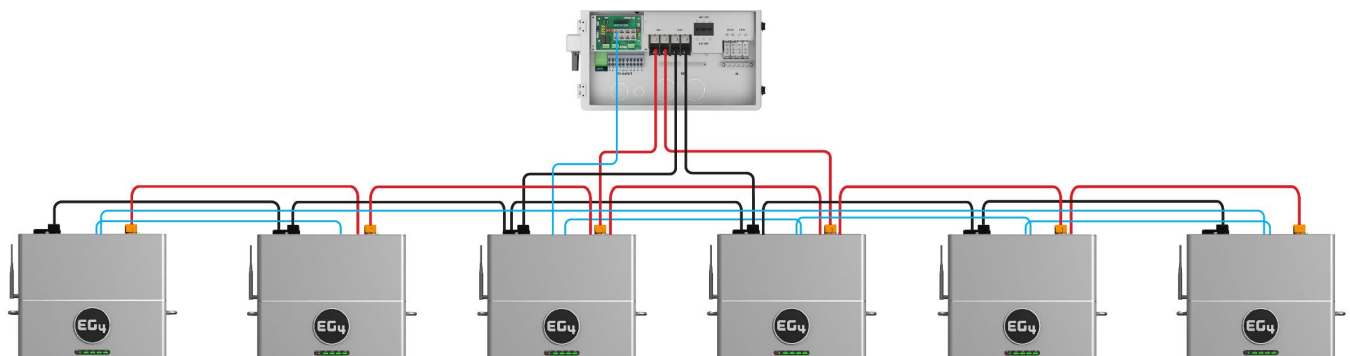

(1) FlexBOSS21 with (6) 314 Indoor



CAUTION:

When pairing the EG4® WallMount 314Ah Indoor battery with an inverter, do not exceed >600A load on the master battery due to the internal busbar rating.

TWO INVERTER CONFIGURATIONS

Illustrations are for representative purposes only.

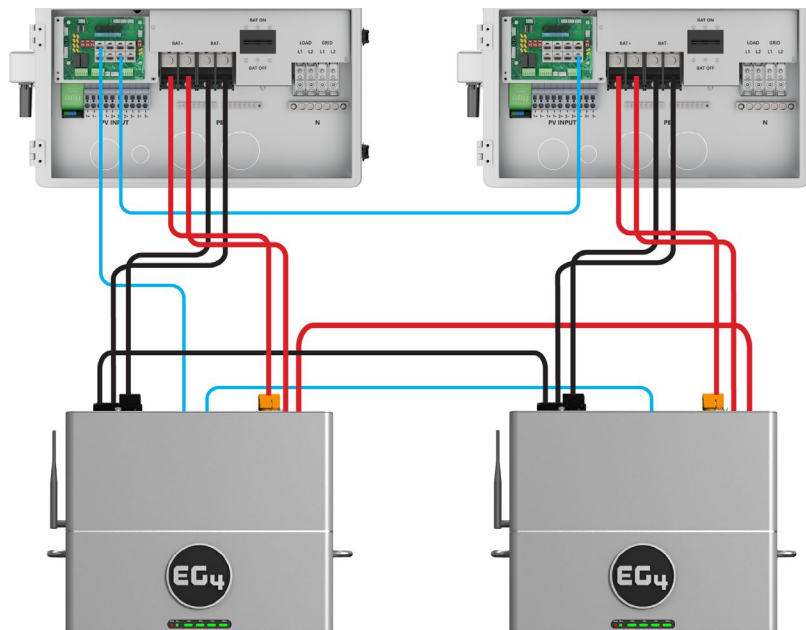

(2) FlexBOSS21 with (2) 314 Indoor

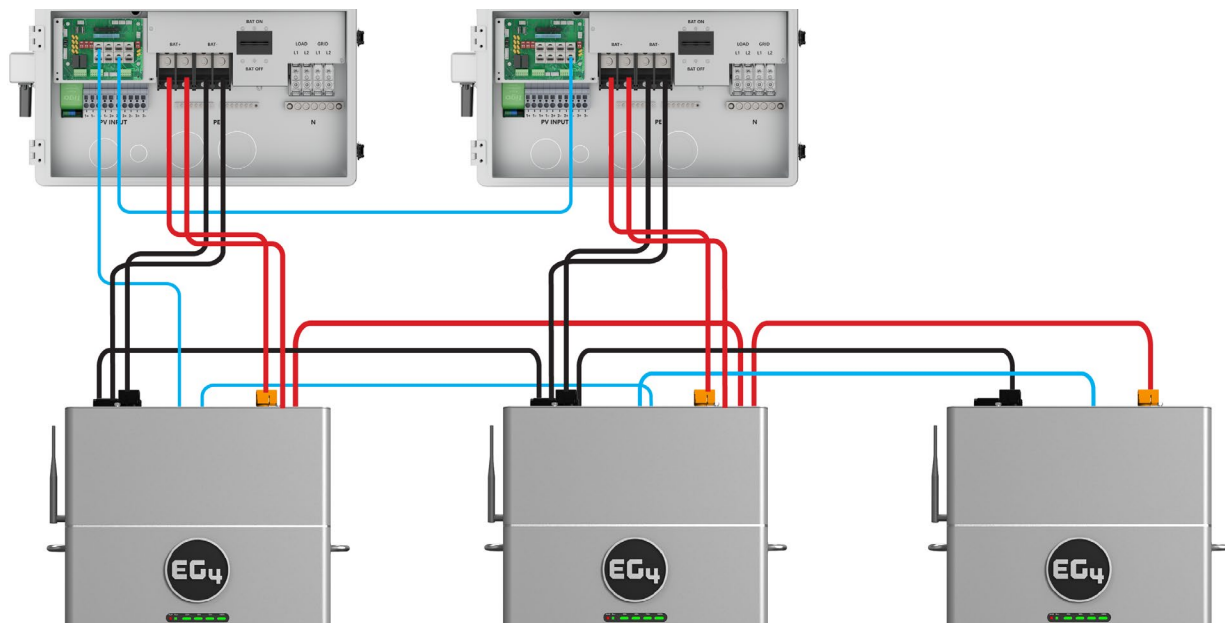

(2) FlexBOSS21 with (3) 314 Indoor



CAUTION:

When pairing the EG4® WallMount 314Ah Indoor Battery with an inverter, do not exceed a load of 600 A on the master battery, as this is the maximum rating of the internal busbar.

Illustrations are for representative purposes only.

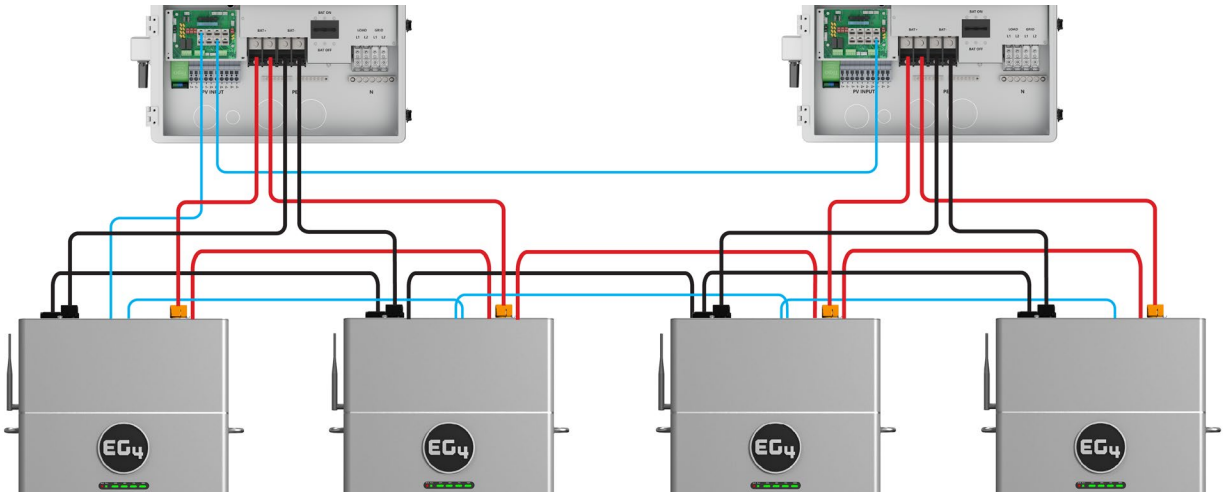

(2) FlexBOSS21 with (4) 314 Indoor

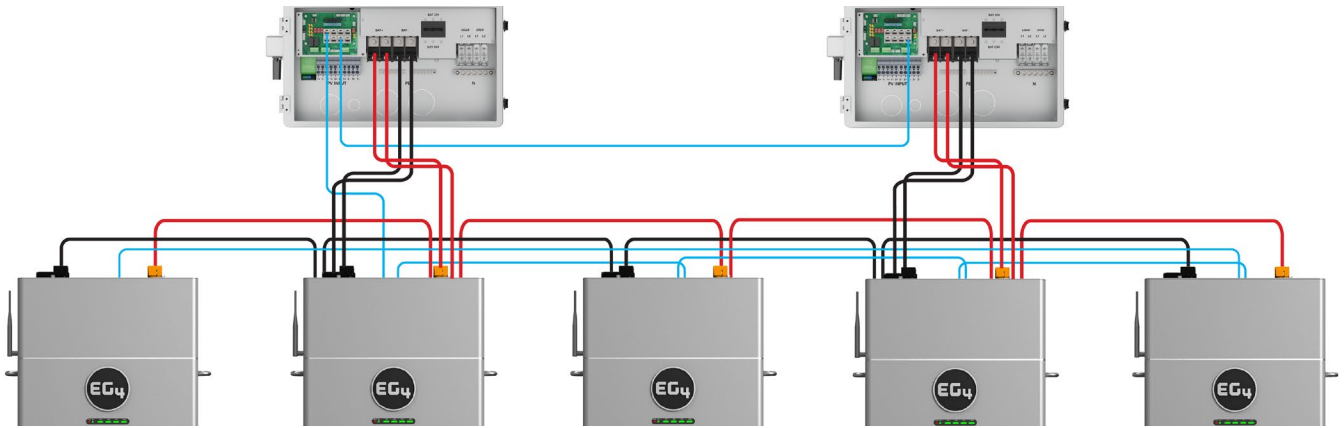

(2) FlexBOSS21 with (5) 314 Indoor

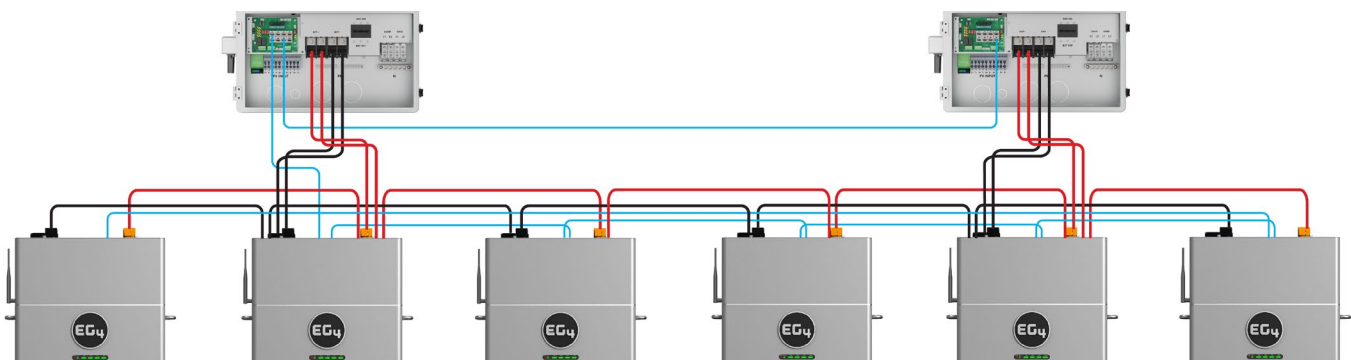

(2) FlexBOSS21 with (6) 314 Indoor



CAUTION:

When pairing the EG4® WallMount 314Ah Indoor Battery with an inverter, do not exceed a load of 600 A on the master battery, as this is the maximum rating of the internal busbar.

THREE INVERTER CONFIGURATIONS

Illustrations for representative purposes only.

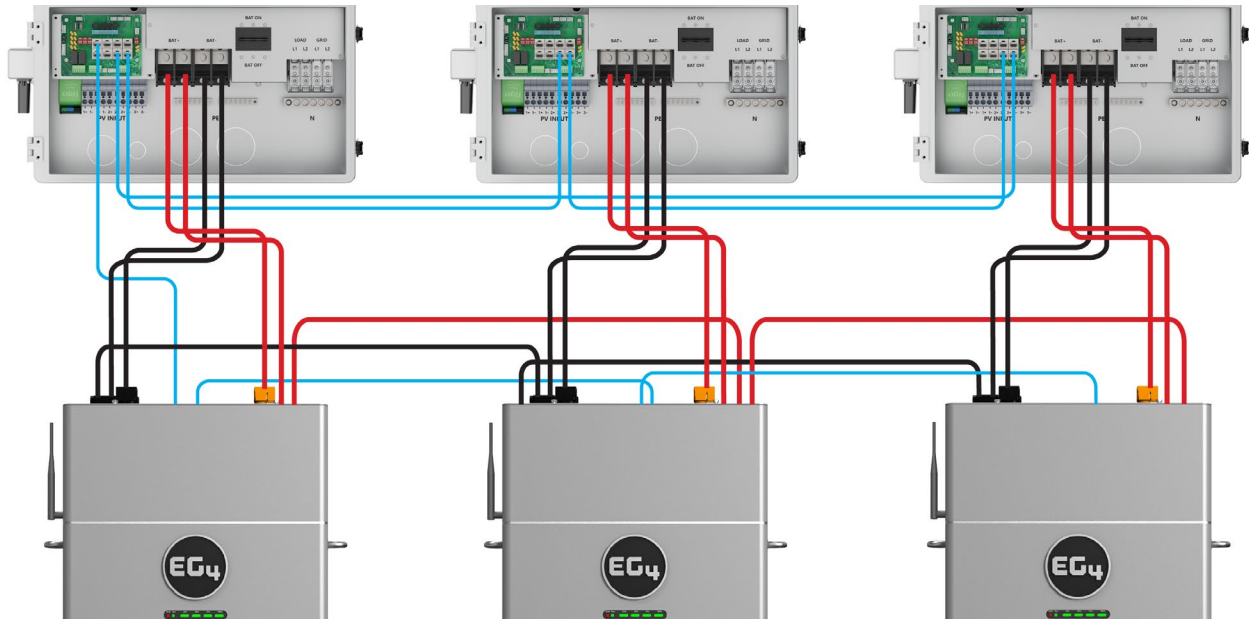

(3) FlexBOSS21 with (3) 314 Indoor

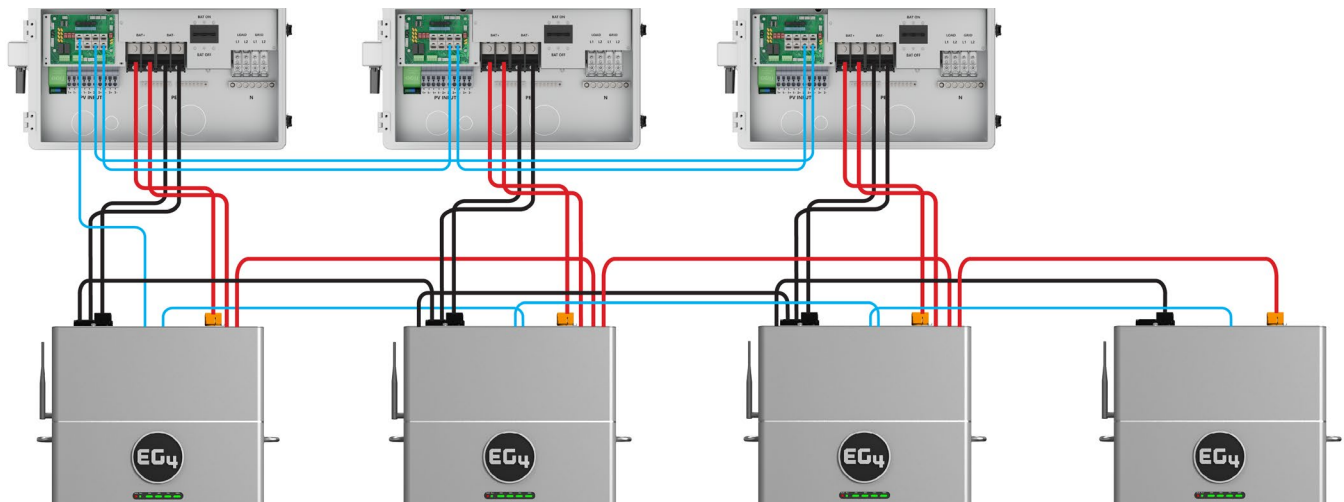

(3) FlexBOSS21 with (4) 314 Indoor



CAUTION:

When pairing the EG4® WallMount 314Ah Indoor battery with an inverter, do not exceed >600A load on the master battery due to the internal busbar rating.

Illustrations for representative purposes only.

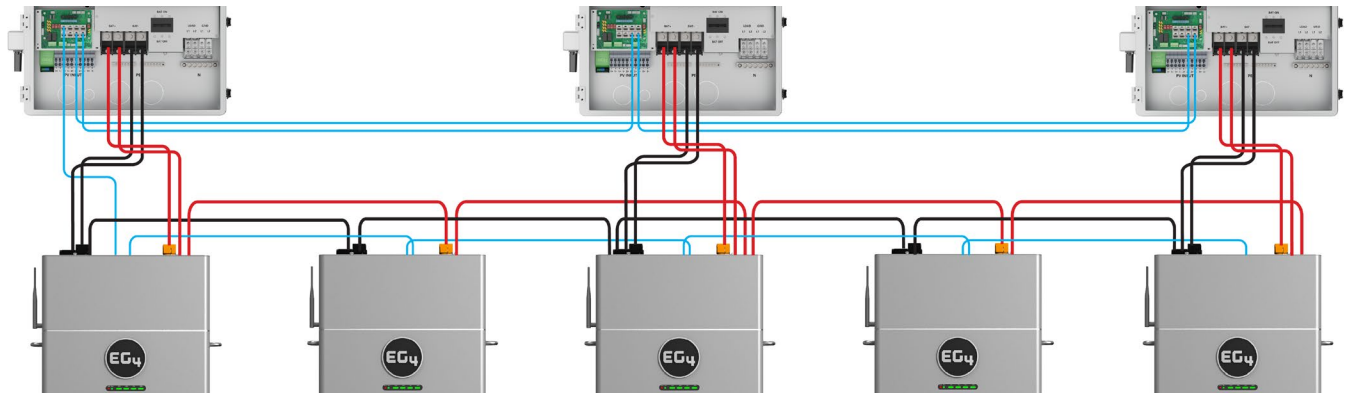

(3) FlexBOSS21 with (5) 314 Indoor

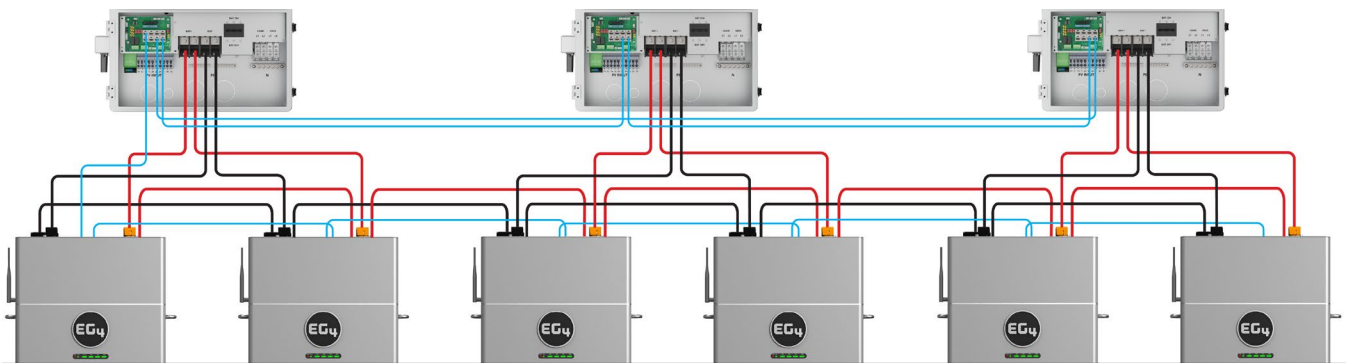

(3) FlexBOSS21 with (6) 314 Indoor



CAUTION:

When pairing the EG4® WallMount 314Ah Indoor battery with an inverter, do not exceed >600A load on the master battery due to the internal busbar rating.

9. BATTERY COMMUNICATIONS

Each EG4® battery integrates seamless communication with the inverter, allowing users to easily monitor and control their system. Advanced communication protocols enable real-time data exchange between the battery and inverter, providing critical information on battery performance, state of charge, and overall system status.

9.1 AUTO-ID BMS PROTOCOL FEATURE

The EG4® WallMount 314Ah Indoor Battery eliminates the need for manual DIP switch configuration or protocol selection. The Auto-ID feature automatically detects the correct inverter communication protocol and assigns unique battery IDs to enable seamless communication in multi-battery systems.

Auto-ID performs two primary functions: protocol detection and ID assignment. When the master battery powers on and establishes a connection, the BMS scans for inverter communication signals and automatically selects the appropriate protocol. For example, when paired with the EG4 FlexBOSS21 inverter, the BMS automatically configures itself to the EG4/Lux protocol without requiring any user intervention.

At the same time, the system assigns the first battery as ID 1 (master). Any additional Auto-ID batteries added to the chain automatically receive unique IDs in the correct sequence. As a result, installers do not need to manually designate a master unit or configure individual batteries; the BMS manages this process automatically. The Auto-ID BMS protocol is available only on EG4 batteries that do not include DIP switches. Scan the QR code below for additional information on Auto-ID BMS protocol features.



9.2 BMS AUTO-ID PROCEDURE



NOTE:

The 120 Ω terminating resistor establishes closed-loop communication between batteries. The inverters listed in Section 9.3 support closed-loop communication with the battery.

1. Verify that all battery breakers in the parallel battery bank are in the OFF position.
2. Verify that all physical connections are secure and correctly installed according to the communication wiring diagrams in Section 8.1.3. Install a 120 Ω terminating resistor in the Comm 1 port of the master battery and another 120 Ω terminating resistor in the Comm 2 port of the last battery in the parallel battery bank.
3. Press the BMS On/Off button to power on the BMS of the master battery. The Auto-ID process will begin and typically completes within 3 – 5 seconds as the master battery assigns IDs to the slave batteries.
4. Power on each remaining battery one at a time at approximately 5-second intervals by pressing the BMS On/Off button, starting with the battery immediately following the master and continuing through the battery bank.
5. Verify that all batteries have been automatically assigned IDs. Confirm that no faults or protection events are active on any battery or inverter after all batteries are powered on.

9.3 COMMUNICATION CABLE PINOUT

EG4® batteries interface with an inverter by designating a “Master” battery (ID 1). The Auto-ID feature automatically assigns the first battery connected to the CAN port as the master battery with ID 1. Available battery ID numbers range from 1 – 32. The battery connects directly to the inverter using a CAT 5, CAT 5e, or CAT 6 cable wired to pins 1 – 5 on the inverter side. For closed-loop CAN bus communication with non-EG4 inverters, refer to the inverter manufacturer’s documentation for specific requirements.

Communication Cable Pinout & Table*

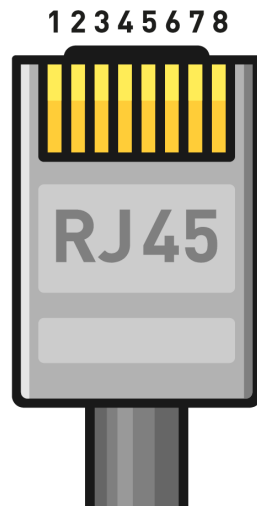

PIN	DESCRIPTION
1	RS485-B
2	RS485-A
3	CAN Ground (optional)
4	CAN High
5	CAN Low

***Pinouts are for battery side;
please refer to the inverter user
manual for pinout
configuration on system end.**

RS485 COMMUNICATION COMPATIBLE INVERTERS:

- EG4
- Growatt
- Schneider
- Voltronic

CAN COMMUNICATION COMPATIBLE INVERTERS:

- EG4
- Growatt
- Deye
- Megarevo
- Luxpower
- Victron
- Solis
- SMA

10. BATTERY STARTUP AND SHUTDOWN PROCEDURE

The battery includes pre-charge resistors that control the startup sequence and enable safe power delivery to the inverter. In 51.2 V nominal voltage systems, these pre-charge resistors are essential for limiting the inrush current requested by the inverter during startup.

10.1 STARTUP

After completing all physical connections and confirming that the inverter is ready to accept battery power, follow the steps below:

1. Close (turn on) the battery's circuit breaker.
2. Wait approximately 5 seconds, then press the power button on the side of the unit to turn on the battery BMS.



NOTE:

When connecting multiple batteries in parallel, repeat the steps above for each battery, always starting with the master battery. This step is crucial to optimizing battery performance.

10.2 SHUTDOWN

1. Press the power button on the side of the unit to turn off the battery BMS.
2. Open (turn off) the battery's circuit breaker.



NOTE:

When operating multiple batteries in parallel, repeat the steps above for each battery, always starting with the master battery.

11. EMERGENCY STOP (RSD/ESS DISCONNECT)

Install an optional ESS disconnect to shut down all batteries and inverters (if equipped) with a single button press, and integrate it with an RSD PV shutdown initiator if required. When multiple batteries are paralleled, connect the ESS disconnect only to the master battery. This safety feature interfaces with the two open RSD contact points on the green terminal block at the top of the battery using two 22 AWG wires. If the inverter includes rapid shutdown (RSD) capability, the inverter's emergency stop function initiates shutdown when the system is properly wired and operating in closed-loop communication. Verify compliance with local AHJ requirements and applicable NEC codes.



NOTE:

When the inverter and WallMount 314Ah Indoor Battery operate in closed-loop communication, certain inverter models can initiate a complete system shutdown—including the batteries—by activating the inverter's rapid shutdown (RSD) function. In this configuration, the two 22 AWG wires are not used to trigger ESS battery shutdown. When supported, the EG4 inverter controls this function directly. Refer to the inverter user manual for additional details.

Verify that the installation complies with all applicable RSD and ESS standards and requirements established by the National Electrical Code (NEC), the local jurisdiction, the fire department, and the utility provider.

11.1 CABLING



NOTE:

Each end of the provided 8-pin dry contact cable are labeled for identification.

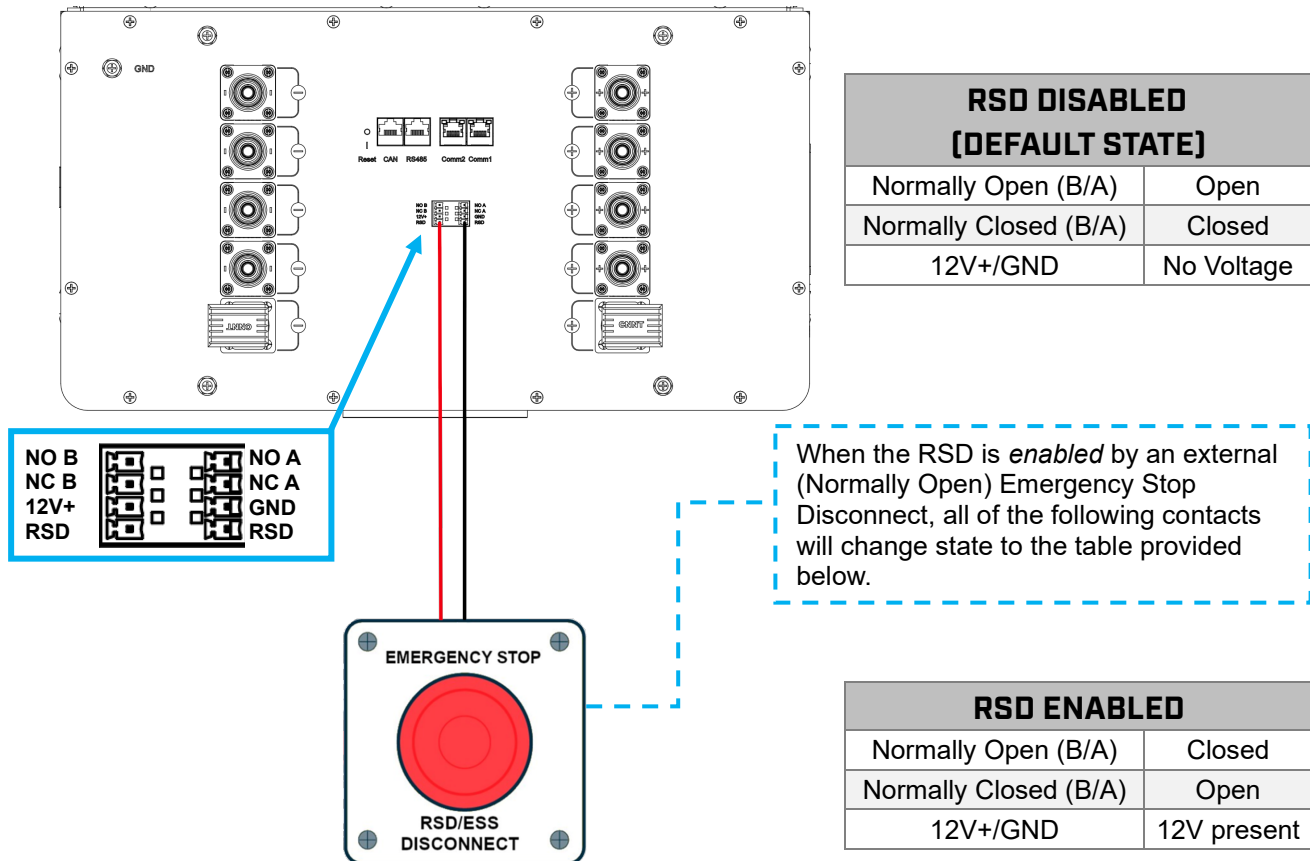

To inverter, RSD Initiator, or ESS Disconnect
(E-Stop recommended if compatible with inverter's RSD system)

Use Normally Open (NO) or Normally Closed (NC) contacts depending on inverter.

12. BMS TOOLS

12.1 OVERVIEW

The PC software “BMS Tools” provides real-time battery analysis and diagnostics. The battery cannot communicate with BMS Tools and a closed-loop inverter at the same time.

12.2 DOWNLOADING AND INSTALLING BMS TOOLS

Visit <https://eg4electronics.com/resources/downloads> to download the latest version of the software. After downloading, unzip the .zip file, then refer to the included PDF for step-by-step instructions on installing and using BMS Tools.

For instructions on how to interface with BMS Tools, please scan the QR codes below.



BMS Tools White Sheet



13. TROUBLESHOOTING, MAINTENANCE & DISPOSAL

ALARM DESCRIPTION AND TROUBLESHOOTING

When the ALM indicator on the battery control panel illuminates, the battery has generated an alarm or activated a protection function to prevent potential damage. Identify the cause of the alarm or fault using the app or BMS Tools, then take appropriate corrective action or visit the battery installation site to troubleshoot as needed.

Battery LED alarms are shown in the tables below:

13.1 LED INDICATOR STATUS AND DEFINITION

STATUS	NORMAL/ ALARM/ PROTECTION	RUN	ALM	SOC INDICATOR LED	NOTES
				SOC1~SOC4	-
Shutdown/Sleep		OFF	OFF	OFF	-
Stand-by	Normal	ON	OFF	Based on battery indicator (Each LED indicates 25% SOC)	-
Charge	Normal	Flash 1	OFF		-
	Alarm	Flash 1	Flash 1		-
	End-off Voltage	ON	OFF		-
	Over-Temp Protection	OFF	ON		-
	Over-current transfer limit current	Flash 1	Flash 3/OFF	Over-current flash 3, limit-current OFF	
Discharge	Normal	Flash 2	OFF	Based on SOC indicator	-
	Alarm	Flash 2	Flash 3		-
	End-off Voltage	OFF	OFF		Go to sleep
	Over-Temp/ Over-current Protection	OFF	ON		-

The following bullets further define the values in the table above:

- **SOC:** Every light represents ~25% capacity
- **Shutdown:** All LED lights are off
- **Power on:** RUN light is always on
- **System failure:** ALM light is always on
- **Flash 1:** Flash once every second
- **Flash 2:** Flash once every 1.5 seconds
- **Flash 3:** Flash once every 2 seconds

WARNING DEFINITIONS AND SOLUTIONS

STATE	TYPE	INDICATOR	SOLUTION
Charge	Over current protection	ALM	Stop charge, check the settings and limitation
	Temperature protection	ALM	Stop charge, wait for the temp to recover
Discharge	Over current protection	ALM	Stop discharge, check if there is an overload
	Temperature protection	ALM	Stop discharge, wait for the temp to recover



WARNING:

The “Historical Record” tab shows events that occurred before the module entered a warning or protection state. Export this data to a text (.txt) file and provide it to the distributor to support troubleshooting. If any warnings or faults from either table persist, contact the distributor for additional troubleshooting assistance.

FAULT DEFINITIONS AND SOLUTIONS

NO.	FAULT	ANALYSIS	SOLUTION
1	Inverter communication failure	Check communication port connection, and battery ID setting.	Check communication wiring and restart BMS. See section 8.1 for wiring information.
2	No DC output	Open breaker, or battery voltage is too low.	Close the battery breaker or charge the battery.
3	Power supply unstable	Battery capacity is not at full power.	Check for proper battery cable connection.
4	Battery cannot be fully charged	DC output voltage is below the minimum charge voltage.	Check charging settings on the inverter to ensure they match battery requirements.
5	ALM LED always on	Short circuit	Disconnect the power cable and check all cables.
6	Battery output voltage is unstable	Battery management system is not operating normally.	Press the reset button to reset the battery, then reboot the system.
7	ALM LED flashes 20 times with SOC1 LED on	Unbalanced voltage within a cell.	Deep discharge the battery bank (<20% SOC), then fully charge the battery bank.
8	ALM LED flashes 20 times with SOC2 LED on	Unbalanced temperature.	Double check the temperature of the battery. If the temperature range is good, restart the battery. If the issue persists, contact the distributor.
9	ALM LED flashes 20 times with SOC3/SOC4 LED on	Battery management system is damaged.	Contact the distributor.
10	Different SOC value of batteries in parallel operation	No issue.	Deep discharge the battery bank (<20% SOC), then fully charge the battery bank.
11	Low voltage protection with no LED on	BMS is in low voltage protection and is in sleep mode.	Fully charge and restart the battery. If issue persists, contact the distributor.
12	Deep discharged with no LED on	Battery voltage is too low to start the BMS	Apply low charge to the battery until BMS is able to start up. If the issue persists, contact the distributor.

13.2 MAINTENANCE

ITEM	MAINTENANCE INTERVAL	MAINTENANCE SOLUTION
Power Cables	Every 6 months	<ol style="list-style-type: none"> 1. Inspect the power cable for any signs of mechanical damage and ensure that the terminal insulation sleeves are intact. If any damage is found, turn off the battery and perform maintenance or replace the cable. 2. Check the power cable for looseness. If the cable is loose, replace it. 3. Examine the system for loose screws. If any screws are found loose, tighten them with the appropriate hardware.
Communication Cables	Every 12 months	<ol style="list-style-type: none"> 1. Verify that the terminals of the parallel communication cable are securely tightened. If any terminal is loose, retighten it. 2. Inspect the communication cable for visible discoloration. If you observe discoloration, shut down the battery and replace the communication cable. Refer to Section 8 for additional information.
System Status	Every 6 months	<ol style="list-style-type: none"> 1. Verify that all operating parameters such as system voltage, current, and temperature remain within normal ranges during system operation. 2. Verify that all primary system components, including switches and contactors, operate correctly.
Charge & Discharge	Every 6 months	Perform a light-load, shallow charge and discharge test to assess the normal operation of the battery's State of Charge (SOC) and State of Health (SOH) using the EG4 monitoring platform to review system parameters. Limit the depth of discharge and charge/discharge power to no more than 20% of the rated value.

13.3 FIRMWARE UPDATE

Verify all system components are fully up to date before commissioning the system. Navigate to the EG4® WallMount 314Ah Indoor battery product page by using the QR code below to find the latest downloads for the battery. A PDF walkthrough will be included in the downloaded .zip file. If encountering difficulties during the updating process, contact the distributor for more information.



13.4 BATTERY END OF LIFE

The EG4® WallMount 314Ah Indoor Battery is designed to operate for more than 15 years when used correctly and limited to no more than one charge–discharge cycle per day. The battery is engineered to retain its charge capacity through thousands of cycles. However, when the battery reaches the end of its service life, consider the following important factors before retiring it.

Lithium iron phosphate (LFP) batteries qualify as hazardous materials and must not be disposed of in household trash. Many organizations and recycling programs accept these batteries for safe disposal, often at little or no cost to the user. Because EG4 serves customers across the United States and worldwide, we recommend searching online for “Lithium Battery Disposal Near Me” to locate approved recycling facilities in your area that can safely handle and recycle LFP batteries.

Call the facility in advance to confirm that it is open and currently accepting materials.

If users cannot locate a safe disposal facility, EG4 is available to assist. Before discarding the battery or disposing of it improperly, contact the EG4 customer service team for guidance.

14. WARRANTY INFORMATION

To register the warranty for EG4® Electronics products, visit <https://eg4electronics.com/warranty/> and select the applicable product to begin the registration process.

15. CHANGELOG

V1.0.2

- Updated the Product Overview callout image and table to clearly differentiate Degson terminals from stud terminals
- Added Firmware Update to section 13
- Corrected typo in Product Overview section
- Updated location requirements to include installations not intended near marine environments
- Changed UL9540A from Pending to Yes
- Modified spec sheet certifications and compliance section
- Updated safety sections
- Updated Intertek/ETL Test Report number in section 7.2

V1.0.1

- Added additional battery model number.
- Added Battery Heater specifications to spec sheet.
- Updated Max Parallel Units from 16 to 32.
- Updated lifetime production value.
- Updated verbiage throughout for readability.
- Updated section 6 headings to properly reflect the sections.

V1.0

- Document published

EG4

ELECTRONICS

support@eg4electronics.com
(903) 609-1988
www.eg4electronics.com