

EG4[®] GRIDBOSS

USER MANUAL



TABLE OF CONTENTS

1.	TECHNICAL SPECIFICATIONS	1
2.	ABBREVIATIONS.....	3
3.	SAFETY	4
3.1	SAFETY INSTRUCTIONS	4
3.2	IMPORTANT SAFETY NOTIFICATIONS.....	4
4.	SÉCURITÉ	6
4.1	INSTRUCTIONS DE SÉCURITÉ	6
4.2	NOTIFICATIONS IMPORTANTES DE SÉCURITÉ.....	6
5.	PRODUCT OVERVIEW.....	8
5.1	DIMENSIONS.....	10
5.2	PACKING LIST.....	11
6.	INSTALLATION.....	12
6.1	MOUNTING AREA & SPACING REQUIREMENTS.....	13
6.2	RECOMMENDED TOOLS.....	15
6.3	MOUNT THE UNIT.....	15
6.4	INSTALL BREAKERS	18
6.5	INSTALL CABLES	24
6.6	CONFIGURE THE HYBRID INVERTERS.....	35
6.7	CONFIGURE GRIDBOSS.....	36
6.8	VERIFY CONFIGURATION	38
7.	SYSTEM OPERATION & CONFIGURATION EXAMPLES.....	40
7.1	HYBRID INVERTERS.....	40
7.2	GENERATOR.....	43
7.3	MANUAL BYPASS MODE.....	44
7.4	SMART LOADS.....	45
7.5	AC COUPLING.....	48
8.	REMOTE SYSTEM MANAGEMENT	50
8.1	CREATE NEW ACCOUNT	51
8.2	EXISTING ACCOUNTS.....	53
9.	EG4 MONITOR CENTER	55
9.1	MAINTENANCE TAB.....	56
10.	FIRMWARE UPDATES	61
10.1	SYSTEM - EG4 MOBILE APP.....	61
10.2	SYSTEM - EG4 MONITOR CENTER	62
10.3	INVERTER LCD – USB DRIVE	63
11.	TROUBLESHOOTING.....	65
11.1	FRONT PANEL LEDS.....	65
11.2	ERROR CODES.....	65
11.3	WARNING CODES.....	66
11.4	INTERNAL FUSE REPLACEMENT.....	67
12.	CHANGELOG	71

1. TECHNICAL SPECIFICATIONS

GRID	
NOMINAL AC VOLTAGE	120/240 VAC (L1/L2/N required)
FREQUENCY	60 Hz
MAXIMUM CURRENT	200A
SERVICE ENTRANCE RATED	22kAIC with 200A Eaton CSR2200N (CSR25K) breaker*
GENERATOR	
NOMINAL VOLTAGE	120/240 VAC (L1/L2/N required)
FREQUENCY	60 Hz
MAXIMUM CURRENT	125A
NON-BACKUP	
NOMINAL VOLTAGE	120/240 VAC (L1/L2/N required)
FREQUENCY	60 Hz
MAXIMUM CURRENT	200A
BACKUP	
NOMINAL VOLTAGE	120/240 VAC (L1/L2/N required)
FREQUENCY	60 Hz
MAXIMUM CURRENT	200A
HYBRID	
NUMBER OF PORTS	3
NOMINAL VOLTAGE	120/240 VAC (L1/L2/N required)
FREQUENCY	60 Hz
MAXIMUM CURRENT PER PORT	90A**
SUPPORTED INVERTERS	EG4® 12kPV, 18kPV, FlexBOSS18, FlexBOSS21***
SMART PORTS	
NUMBER OF PORTS	4
NOMINAL VOLTAGE	120/240 VAC (L1/L2/N required)
FREQUENCY	60 Hz
MAXIMUM CURRENT PER PORT	1: 125A 2: 80A 3: 60A 4: 60A
GENERAL DATA	
COMMUNICATION INTERFACE	RS485/Wi-Fi/CAN
IDLE CONSUMPTION	~55W
TRANSFER TIME	~25 ms
INTERNAL BUS RATING	350A (software limited to 200A)
INTERNAL FUSE RATING	315A
OPERATING ALTITUDE	<6561 ft (<2000 m)
RELATIVE HUMIDITY	0 – 100%
OUTDOOR RATING	NEMA 3R
OPERATING AMBIENT TEMPERATURE RANGE	-40°F – 113°F (-40°C – 45°C)
PRODUCT DIMENSIONS (H×W×D)	31.5×19.7×7 in (800×500×178 mm)
UNIT WEIGHT	55 lbs. (25 kg)
STANDARD WARRANTY	10-year standard warranty****

*US only

**Install a properly sized breaker for the attached inverter: 50A - 12kPV | 70A - 18kPV, FlexBOSS18 | 90A - FlexBOSS21.

***Third-party inverters are not supported and cannot be connected to the hybrid ports.

****For information regarding warranty registration on EG4® Electronics products, please navigate to <https://eg4electronics.com/warranty/> and select the corresponding product to begin the registration process.

STANDARDS AND CERTIFICATIONS

UL1741, UL67, UL869A*, CSA C22.2#29:2015 ED.6+U1**

FCC PART 15, CLASS B

*When used with a 200A Eaton CSR2200N (CSR25K) main breaker, US only

**Model MI-200-2P-HYB-AW-02, not service entrance rated.

2. ABBREVIATIONS

- AWG – American Wire Gauge
- A – Amps
- Ah – Amp hour(s)
- AC – Alternating Current
- AFCI – Arc-Fault Circuit Interrupter
- AHJ – Authority Having Jurisdiction
- kAIC – kilo-Amp Interrupting Capability
- ANSI – American National Standards Institute
- BAT – Battery
- BMS – Battery Management System
- COM – Communication
- CT – Current Transformer
- DC – Direct Current
- DIP – Dual In-line Package
- DOD – Depth of Discharge
- EG – Equipment Ground
- EGS – Equipment Grounding System
- EMC – Electromagnetic Compatibility
- EPS – Emergency Power System
- ESS – Energy Storage System
- E-Stop – Emergency Stop
- FCC – Federal Communication Commission
- GE – Grounding Electrode
- GEC – Grounding Electrode Conductor
- GFCI – Ground Fault Circuit Interrupter
- GFDI – Ground Fault Detector/Interrupter
- Imp – Maximum Power Point Current
- IEEE – Institute of Electrical and Electronic Engineers
- IP – Ingress Protection
- Isc – Short-Circuit Current
- In-lbs. – Inch Pounds
- kW – Kilowatt
- kWh – Kilowatt-hour
- LCD – Liquid Crystal Display
- LFP – Lithium Iron Phosphate
- L1 – Line 1
- L2 – Line 2
- mm – Millimeters
- MPPT – Maximum Power Point Tracking
- mV – Millivolt
- N – Neutral
- NEC – National Electric Code
- NEMA – National Electrical Manufacturers Association
- NFPA – National Fire Prevention Association
- Nm – Newton Meters
- NOCT – Normal Operating Cell Temperature
- PC – Personal Computer
- PCB – Printed Circuit Board
- PE – Protective Earth
- PPE – Personal Protective Equipment
- PV – Photovoltaic
- RSD – Rapid Shut Down
- SCC – Standards Council of Canada
- SOC – State of Charge
- STC – Standard Testing Conditions
- UL – Underwriters Laboratories
- UPS – Uninterrupted Power Supply
- V – Volts
- VOC – Open-Circuit Voltage
- VMP – Voltage Maximum Power

3. SAFETY

3.1 SAFETY INSTRUCTIONS

International safety regulations have been strictly observed in the design and testing of the GridBOSS. Before beginning any work, carefully read all safety instructions and always observe them when working on or with the inverter. The installation must follow all applicable national or local standards and regulations.

Incorrect installation may cause:

- Injury or death to the installer, operator, or third party
- Damage to the inverter or other attached equipment

3.2 IMPORTANT SAFETY NOTIFICATIONS



DANGER: Hazardous Voltage Circuits!

There are various safety concerns that must be carefully observed before, during, and after the installation, as well as during future operation and maintenance. The following are essential safety notifications for this product's installer and end users under normal operating conditions.

1. **Beware of high grid voltage.** Ensure the AC switch and/or AC breaker are in the “off” or “open” position before installing or working on the inverter. Use a voltmeter to confirm there is no voltage present to avoid electric shock.
2. **Do not open the internal GridBOSS cover while it is operating to avoid electric shock and damage from live voltage and current within the system.**
3. Do not make any connections or remove any connections while GridBOSS is operating.
4. An installer should make sure to be well protected by reasonable and professional insulative equipment [e.g., personal protective equipment (PPE)].
5. Before installing, operating, or maintaining the system, it is important to inspect all existing wiring to ensure that it meets the appropriate specifications and conditions for use.
6. Ensure the grid connections to the inverter are secure and proper to prevent damage or injuries caused by improper installation.
7. Some components of the system can be very heavy. Be sure to utilize team-lift, among other safe lifting techniques, throughout the installation.



WARNING: TO REDUCE THE RISK OF INJURY, READ ALL INSTRUCTIONS!

All work on this product (system design, installation, operation, setting, configuration, and maintenance) must be carried out by qualified personnel. To reduce the risk of electric shock, do not perform any service other than those specified in the operating instructions unless qualified to do so.

1. Read all the instructions before installation. For electrical work, follow all local and national wiring standards, regulations, and these installation instructions.
2. Make sure all equipment is properly grounded. All wiring should be in accordance with the National Electrical Code (NEC), ANSI/NFPA 70.
3. The system can interconnect with the utility grid only if the utility provider permits. Consult with the local AHJ (Authority Having Jurisdiction) before installing this product for any additional regulations and requirements for the immediate area.
4. All warning labels and nameplates on the inverter should be clearly visible and must not be removed or covered.
5. The installer should consider the safety of future users when choosing the correct position and location for the GridBOSS as specified in this manual.
6. Keep children from touching or misusing the inverter and relevant systems.
7. **Beware!** Do not connect any DC connections to the GridBOSS.



WARNING!

Cancer and Reproductive Harm – See www.P65Warnings.ca.gov for more details.

DISCLAIMER

EG4® reserves the right to make changes to the material herein at any time without notice. Please refer to www.eg4electronics.com for the most updated version of our manuals/spec sheets.

4. SÉCURITÉ

4.1 INSTRUCTIONS DE SÉCURITÉ

Les réglementations internationales de sécurité ont été strictement observées dans la conception et les tests du GridBOSS. Avant de commencer tout travail, lisez attentivement toutes les instructions de sécurité et respectez-les toujours lorsque vous travaillez sur ou avec l'onduleur. L'installation doit suivre toutes les normes et réglementations nationales ou locales applicables.

Une installation incorrecte peut causer :

- Des blessures ou la mort de l'installateur, de l'opérateur ou d'un tiers
- Des dommages à l'onduleur ou à d'autres équipements connectés

4.2 NOTIFICATIONS IMPORTANTES DE SÉCURITÉ



DANGER : Circuits de tension dangereuse !

Il existe divers problèmes de sécurité qui doivent être soigneusement observés avant, pendant et après l'installation, ainsi que pendant l'exploitation et la maintenance futures. Les notifications de sécurité suivantes sont essentielles pour l'installateur et les utilisateurs finaux de ce produit dans des conditions normales de fonctionnement.

1. **Méfiez-vous de la haute tension du réseau.** Assurez-vous que l'interrupteur AC et/ou le disjoncteur AC sont en position "off" ou "ouvert" avant d'installer ou de travailler sur l'onduleur. Utilisez un voltmètre pour confirmer qu'il n'y a pas de tension présente afin d'éviter les chocs électriques.
2. **Ne pas ouvrir le couvercle interne du GridBOSS pendant son fonctionnement pour éviter les chocs électriques et les dommages dus à la tension et au courant en direct dans le système.**
3. Ne pas effectuer de connexions ni retirer de connexions pendant que le GridBOSS fonctionne.
4. Un installateur doit s'assurer d'être bien protégé par un équipement isolant raisonnable et professionnel (par exemple, équipement de protection individuelle - EPI).
5. Avant d'installer, d'exploiter ou de maintenir le système, il est important d'inspecter tous les câblages existants pour s'assurer qu'ils répondent aux spécifications et conditions appropriées pour l'utilisation.
6. Assurez-vous que les connexions du réseau à l'onduleur sont sécurisées et appropriées pour éviter les dommages ou les blessures causés par une installation incorrecte.
7. Certains composants du système peuvent être très lourds. Assurez-vous d'utiliser des techniques de levage en équipe, parmi d'autres techniques de levage sûres, tout au long de l'installation.



AVERTISSEMENT : POUR RÉDUIRE LE RISQUE DE BLESSURE, LISEZ TOUTES LES INSTRUCTIONS !

Tous les travaux sur ce produit (conception du système, installation, exploitation, réglage, configuration et maintenance) doivent être effectués par du personnel qualifié. Pour réduire le risque de choc électrique, ne réalisez aucun service autre que ceux spécifiés dans les instructions de fonctionnement, sauf si vous êtes qualifié pour le faire.

1. Lisez toutes les instructions avant l'installation. Pour les travaux électriques, suivez toutes les normes et réglementations locales et nationales de câblage, ainsi que ces instructions d'installation.
2. Assurez-vous que tout l'équipement est correctement mis à la terre. Tous les câblages doivent être conformes au Code National de l'Électricité (NEC), ANSI/NFPA 70.
3. Le système peut se connecter au réseau public uniquement si le fournisseur de services publics le permet. Consultez l'autorité locale compétente (AHJ) avant d'installer ce produit pour toute réglementation et exigence supplémentaire pour la zone immédiate.
4. Toutes les étiquettes d'avertissement et les plaques signalétiques sur l'onduleur doivent être clairement visibles et ne doivent pas être retirées ou couvertes.
5. L'installateur doit prendre en compte la sécurité des futurs utilisateurs lors du choix de la position et de l'emplacement corrects pour le GridBOSS, comme spécifié dans ce manuel.
6. Empêchez les enfants de toucher ou de mal utiliser l'onduleur et les systèmes pertinents.
7. **Attention !** Ne connectez aucune connexion DC au GridBOSS.



AVERTISSEMENT !

Cancer et dommages reproductifs – Voir www.P65Warnings.ca.gov pour plus de détails.

DISCLAIMER

EG4® se réserve le droit de modifier le contenu de ce document à tout moment sans préavis. Veuillez consulter www.eg4electronics.com pour la version la plus récente de nos manuels/fiches techniques.

5. PRODUCT OVERVIEW

The EG4® GridBOSS is a service entrance-rated intelligent power distribution device that utilizes software, relays, and programmable smart ports to direct power to where and when it's needed. There are four possible sources of AC input to support various system design needs: the grid, up to three hybrid inverters, a generator, and AC coupling ports. The system can output power to the backup loads port, the smart ports, and the non-backup loads port. Common uses for smart ports include power shedding for various loads, such as electric vehicles, water heaters, and HVAC units. Smart ports are also used for attaching AC-coupled photovoltaic (PV) systems, which provide another source of power. The unit supports an AC pass-through current of up to 200 amps, providing end users with intelligent distribution solutions. Common application scenarios are illustrated in the image below, along with the configuration examples outlined in Section 7.

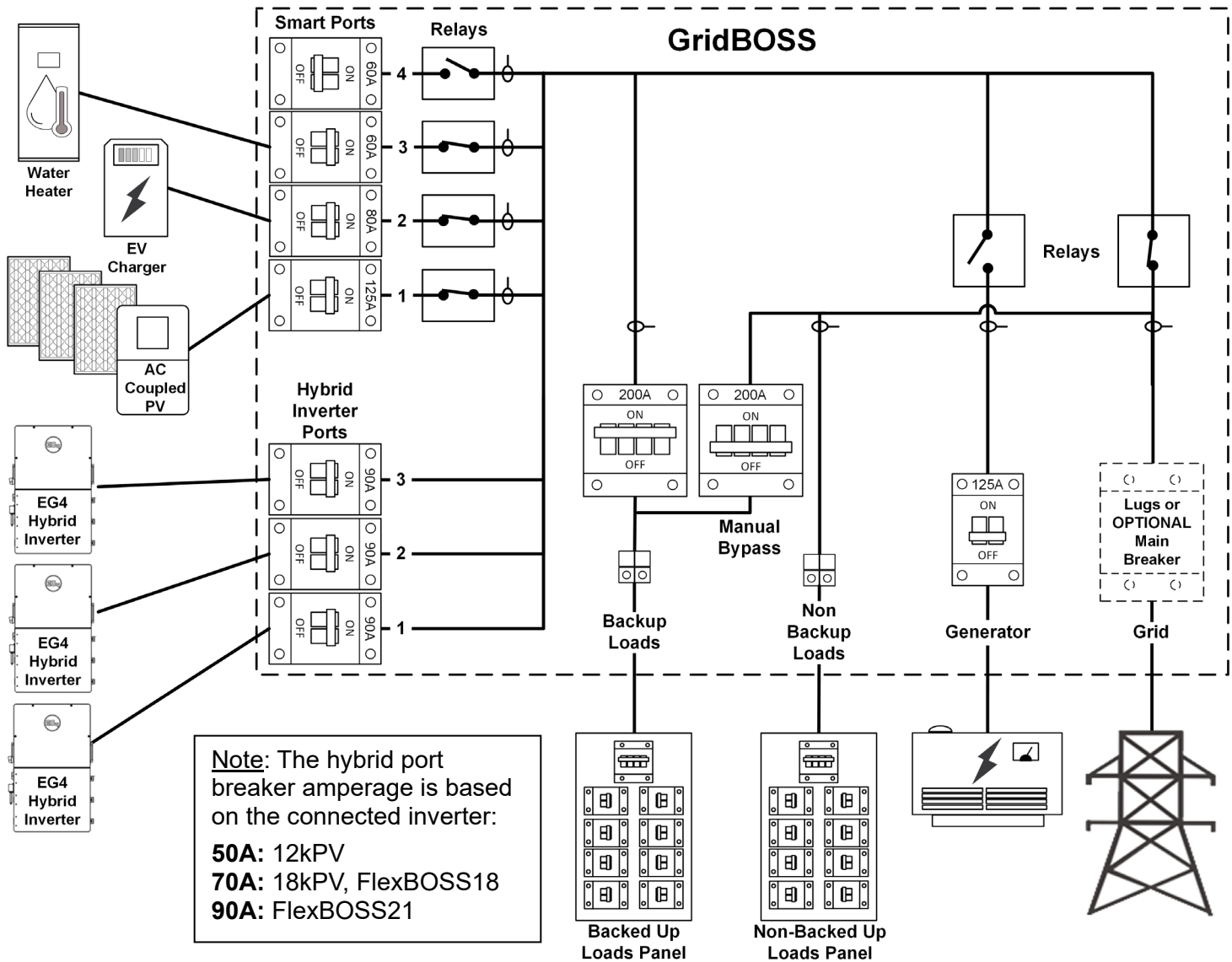

IMPORTANT:

The breakers displayed in the image above are the maximum supported sizes for each port. The maximum allowed total output amperage is set at 200 amps. If the current draw exceeds 200A, GridBOSS will begin to limit load output.

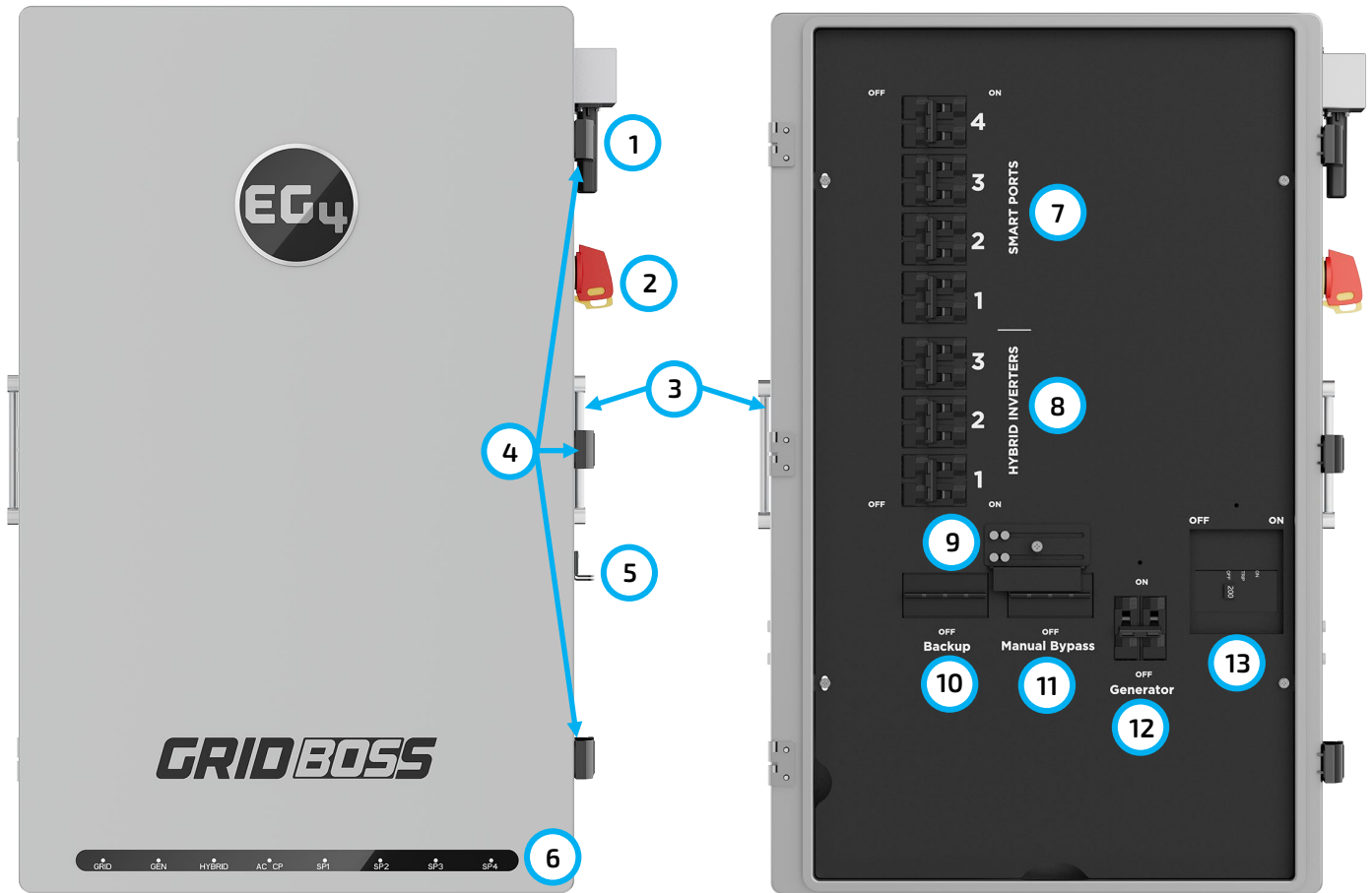

ITEM	DESCRIPTION
1	Wi-Fi dongle
2	RSD/ESS switch
3	Chassis handles
4	Door latches
5	Door lock mechanism for padlock
6	Port LEDs
7	Smart port breakers
8	Hybrid port breakers
9	Manual bypass interlock
10	Backup port breaker
11	Manual bypass breaker
12	Generator breaker
13	Grid breaker (optional)

5.1 DIMENSIONS

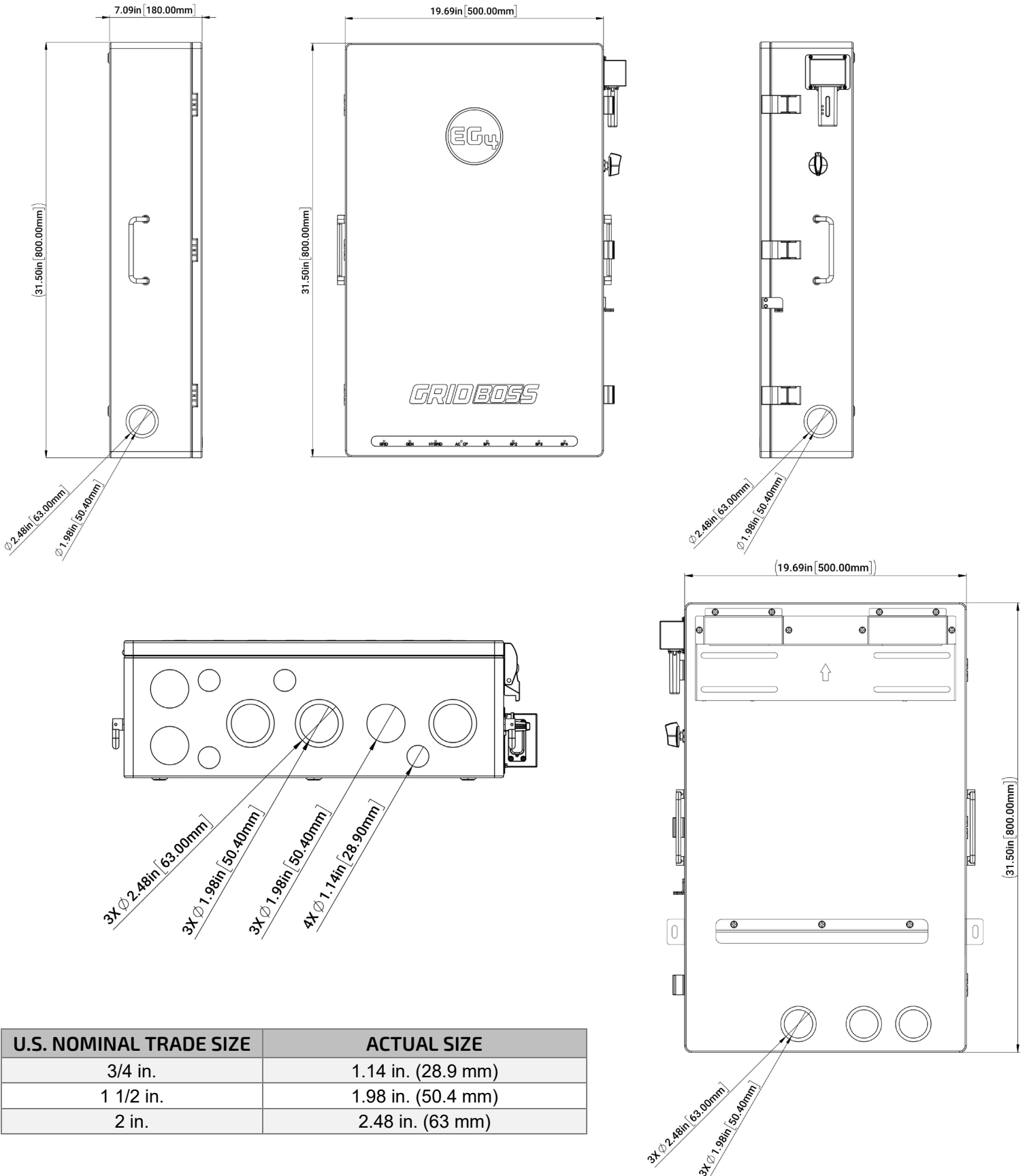

5.2 PACKING LIST

The items listed below will arrive with each product shipment:

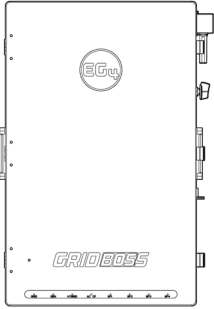

GridBOSS (x1)

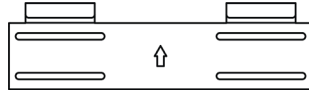

Mounting Bracket (x1)



Neutral-Ground Bonding Jumper (x1)

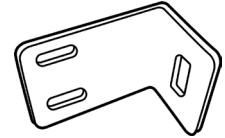

L-Bracket (x2)

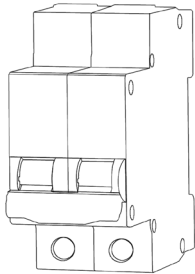

Two Pole Breaker (x8)*



Breaker Cover (x)

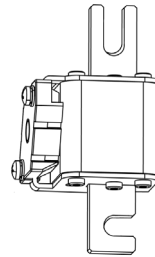

Extra Fuse (x2)

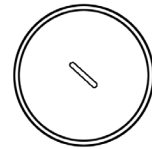

Waterproof Cover

- M63 (x8)
- G-M50 (x3)
- G-P21 (x4)

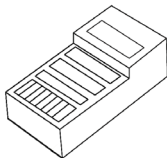

RJ45 Connector (x3)

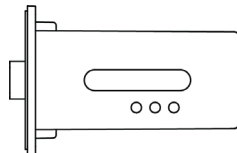

Wi-Fi Dongle (x1)



Expansion Screws & Tubes (x6)

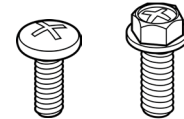

Cross Head Screws:

- M4-0.7x12 mm (x2)
- M5-0.8x10 mm (x4)
- M5-0.8x16 mm (x4)
- M6-1x38 mm (x1)

*Included breakers: 30A (x1), 40A (x1), 60A (x2), 80A (x1), 90A (x3)

6. INSTALLATION

This section provides detailed steps for installing and configuring the GridBOSS. It is recommended to complete each section in the order listed below.

Installation Steps:

- 6.1 Mounting area and spacing requirements
- 6.2 Recommended tools
- 6.3 Mount the unit
- 6.4 Install breakers
- 6.5 Install cables
- 6.6 Configure hybrid inverters
- 6.7 Configure GridBOSS
- 6.8 Verify Configuration



WARNING:

GridBOSS has multiple models that are directly tied to hardware changes. When installing GridBOSS, verify the user manual matches the specific model number being installed. Using the wrong version of the manual may lead to compliance or certification issues, installation errors, potential harm to the installer, or possible damage to the GridBOSS and its connected components.

For additional information, use the QR code to view the “GridBOSS Model Versioning Whitepaper.”



The model number is on the informational sticker on the lower left side of the GridBOSS chassis.

EG4 ELECTRONICS		Grid BOSS
Model	MI-200-2P-HYB-AW-03	
Grid		
Nominal Voltage	120/240VAC	
Frequency	60Hz	
Maximum Current	200A	
Adjustable Displacement Factor Range	+/-0.8	
Generator		
Nominal Voltage	120/240VAC	
Frequency	60Hz	
Maximum Current	125A	
Non Backup		
Nominal Voltage	120/240VAC	
Frequency	60Hz	
Maximum Current	200A	



The model number in the User Manual is found on the cover page in the lower left corner.



©2025 EG4® ELECTRONICS, LLC. ALL RIGHTS RESERVED.
VERSION 2.0.0 | INFORMATION SUBJECT TO CHANGE WITHOUT NOTICE.
MODEL #: MI-200-2P-HYB-AW-03

6.1 MOUNTING AREA & SPACING REQUIREMENTS

Follow the requirements listed below for system installation:

1. The mounting wall must be strong enough to support the weight of all equipment (GridBOSS, inverters, wall-mounted batteries, etc.).
2. Maintain the minimum clearances on all sides (see next page).
3. Ensure the mounting surface is made of non-combustible material.
4. Ensure the final installation location has adequate room for making electrical connections and servicing the unit.
5. Avoid placing the GridBOSS in direct sunlight.
6. The installation location must have a maximum relative humidity of 100%.
7. The location must have a minimum ambient temperature of -40°F (-40°C) and a maximum ambient temperature of 113°F (45°C).
8. Do not install the equipment in an environment near combustible materials.
9. The maximum supported distance between the GridBOSS and attached hybrid inverters is 260 feet (80 meters). This distance supports proper communication between the GridBOSS and the inverter using a CAT5 or higher specification straight-through network cable in the 568B format.
10. When mounting the unit, ensure the installation location complies with local codes and the requirements of UL 514B.
11. Position the unit on a vertical surface. Do not install the unit upside down!

Must be installed vertically between a 75° – 90° angle.

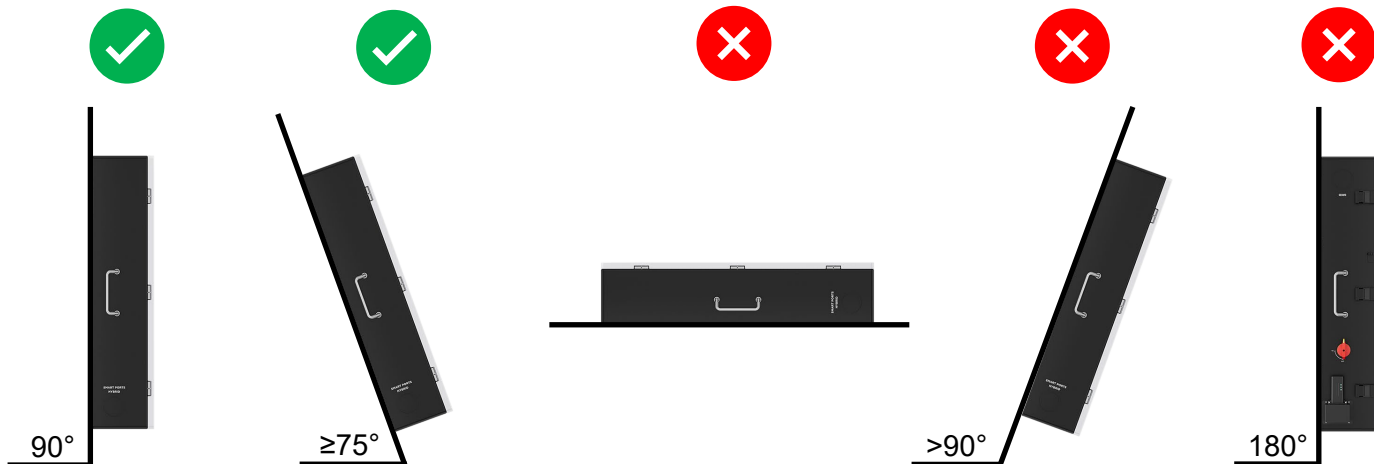

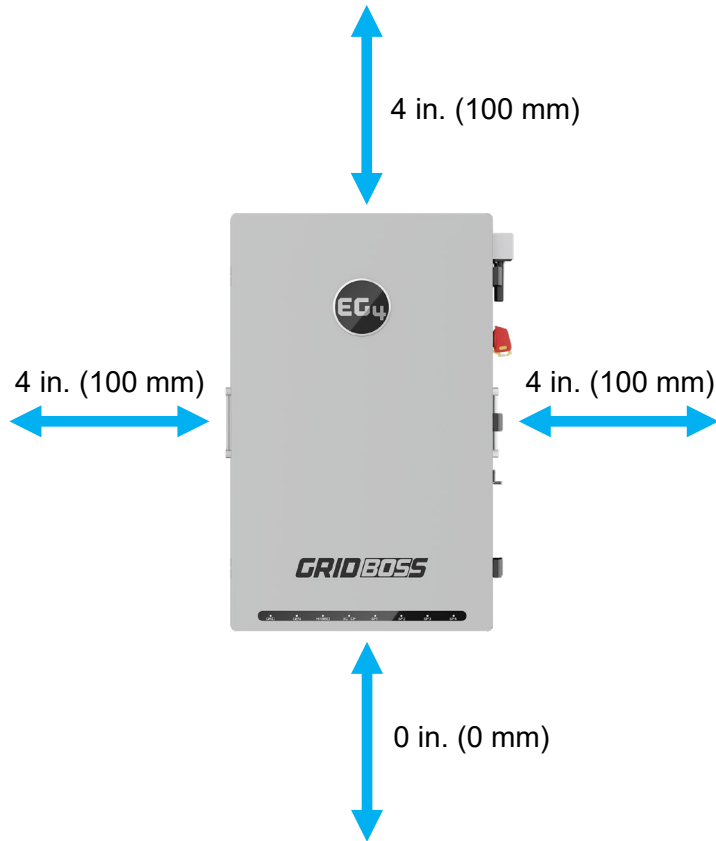

Be sure to maintain the spacing requirements shown in the image to allow access to fully open the door and to view the dongle LEDs.

Ensure there is adequate space in front of the unit to allow for working space and clearance for the front cover to swing open.

The GridBOSS is designed to be wall mounted using the included wall mount bracket.

It should be installed vertically on a solid, non-combustible surface such as brick or concrete.

The mounting bracket's slots can accommodate stud spacings from 12 in. (305 mm) to 16 in. (406 mm).

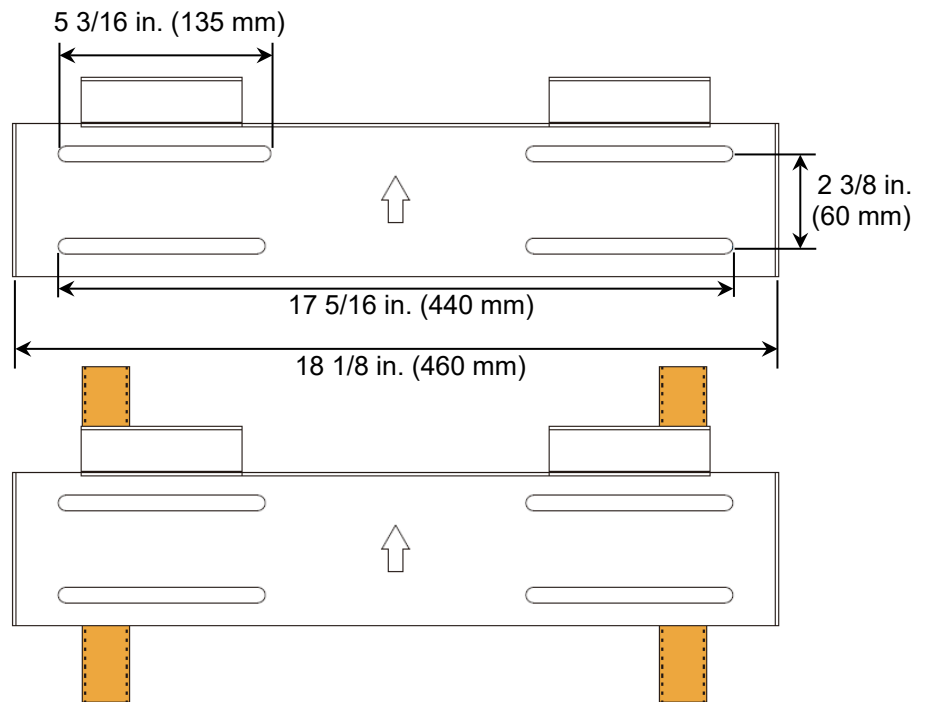

6.2 RECOMMENDED TOOLS



6.3 MOUNT THE UNIT

1. Select a suitable location to install the GridBOSS as described in section 6.1.
2. Use the wall mounting bracket as a template to mark where the screws will be installed. When installing the wall bracket to studs, verify that the marks for the screws are centered over a stud.

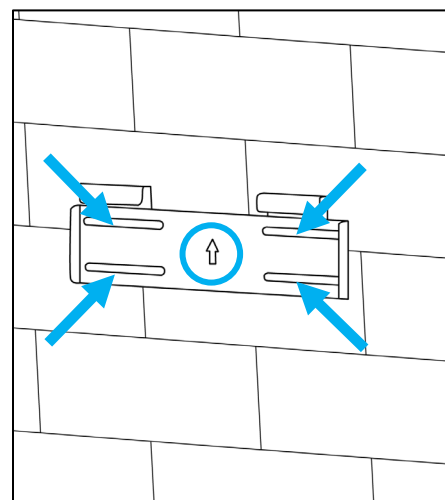

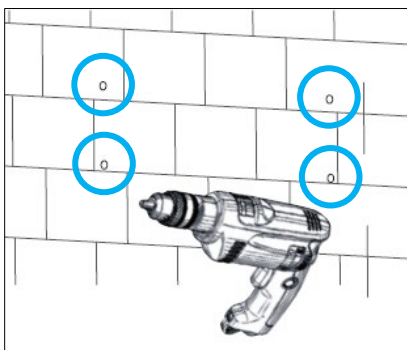

3. When installing the bracket to concrete or brick, drill 25/64-inch (10 mm) diameter holes on the marks, ensuring the holes are deeper than 3-3/16 in. (80 mm) when using the included expansion bolts.

When installing the bracket to a stud, drill a pilot hole recommended for the screw diameter used. (screws not included)

4. For concrete or brick wall installation, insert the expansion bolts into the drilled holes. Install the bracket to the wall, ensuring the arrow is pointing up. Use the corresponding nuts and washers (packaged with the expansion bolts) to affix the bracket to the wall.

For stud wall installation, use the proper screws and affix the bracket to the wall.

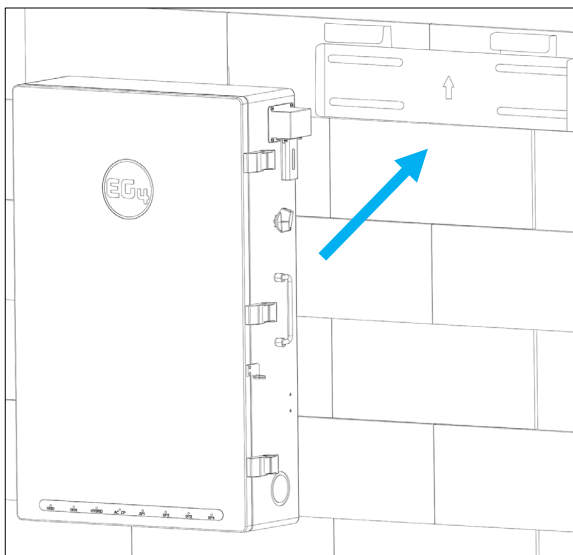
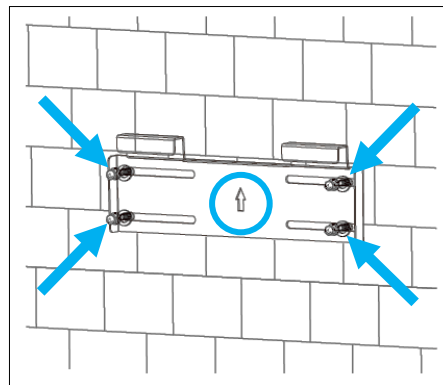

5. Using the team-lift technique, place the GridBOSS onto the wall bracket and secure it to the wall.

6. Temporarily mount the L-bracket to the side of the GridBOSS (located at the bottom, one on each side). Place a mark on the wall based on the hole location inside the L-bracket. Repeat this step for both sides.

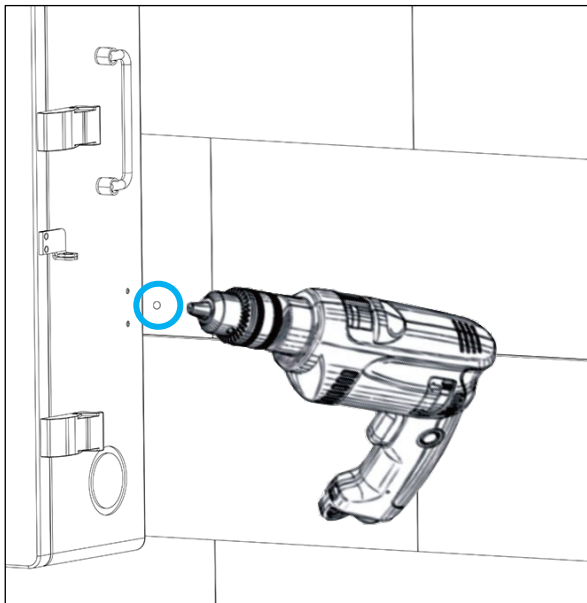
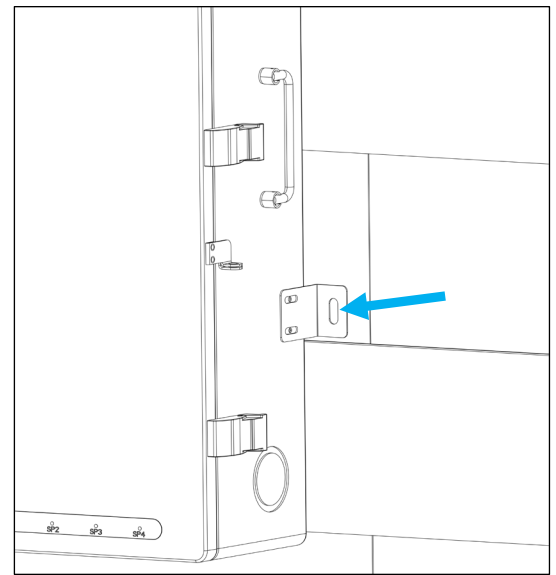

7. Remove the L-bracket and drill a hole at the marking. Use the drill bit size based on the anchor type or screw size as directed in step 3. Repeat this step for both sides.

8. Use the correct hardware to attach the L-brackets (one on each side) to the GridBOSS and to the wall. Once the bracket is secure, the wall installation is complete.

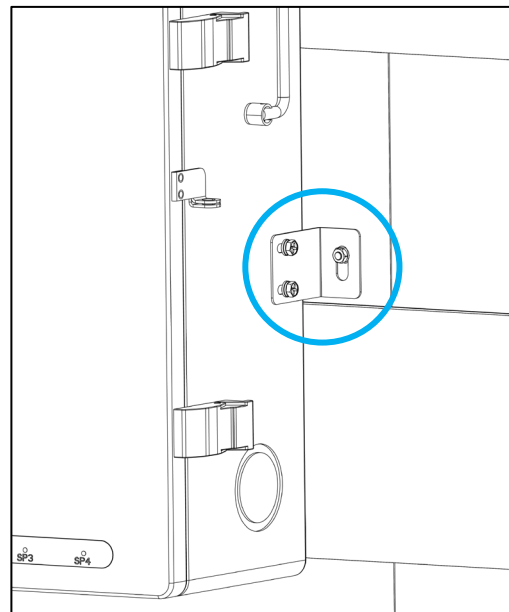

6.4 INSTALL BREAKERS

This section outlines the steps for installing the hybrid, generator, smart port, and main (optional) breakers.

To begin the installation, open the front door by releasing the clasps on the right side of the unit. Next, remove the four screws as identified in the image below and then carefully remove the inner black cover by lifting it out of the chassis. Once the cover is removed, use the information in this section for guidance on installing each breaker.



DANGER:

If a breaker is installed after the system is in operation, verify that all breakers are in the OFF position and that there is no voltage at each breaker and lug connection point.



Breaker Placement and Installation:

Use the table below when installing the breakers supplied from the packing list.

SIZE	QUANTITY SHIPPED	SUPPORTED PORT LOCATIONS
30A	1	Smart Ports 1 – 4 & Generator
40A	1	Smart Ports 1 – 4 & Generator
60A	2	Smart Ports 1 – 4 & Generator
80A	1	Smart Ports 1 & 2 & Generator
90A	3	Hybrid Ports 1-3 and Smart Port 1

If an additional breaker is needed, use the chart below to identify the breaker size supported at each port location. Any additional breakers should be purchased from an EG4 distributor to ensure a supported breaker model is installed.

PORT	SUPPORTED BREAKER SIZES	MODEL #	SOURCE
Grid	200A	Eaton CSR2200N (CSR25K)	Anywhere
Non-Backup	No breaker, lug only	-	-
Backup	200A (pre-installed, non-changeable)	B3T1-200	EG4
Manual Bypass	200A (pre-installed, non-changeable)	B3T1-200	EG4
Generator	30A, 40A, 60A, 80A, 100A, 125A	B3S1 – 30, 40, 60, 80, 100, 125	EG4
Hybrid 1 – 3	12kPV: 50A 18kPV, FlexBOSS18: 70A FlexBOSS21: 90A	B3S1 – 50, 70, 90	EG4
Smart Port 1	90A, 100A, 125A	B3S1 – 90, 100, 125	EG4
Smart Port 1 & 2	70A, 80A	B3S1 – 70, 80	EG4
Smart Port 1 – 4	30A, 40A, 50A, 60A	B3S1 – 30, 40, 50, 60	EG4

Breaker Installation:

When installing a 2-pole breaker, hold it at an angle and place the bottom slot on the metal bracket inside the GridBOSS chassis. Then, pivot the breaker towards the chassis until the top snaps onto the busbar blade.

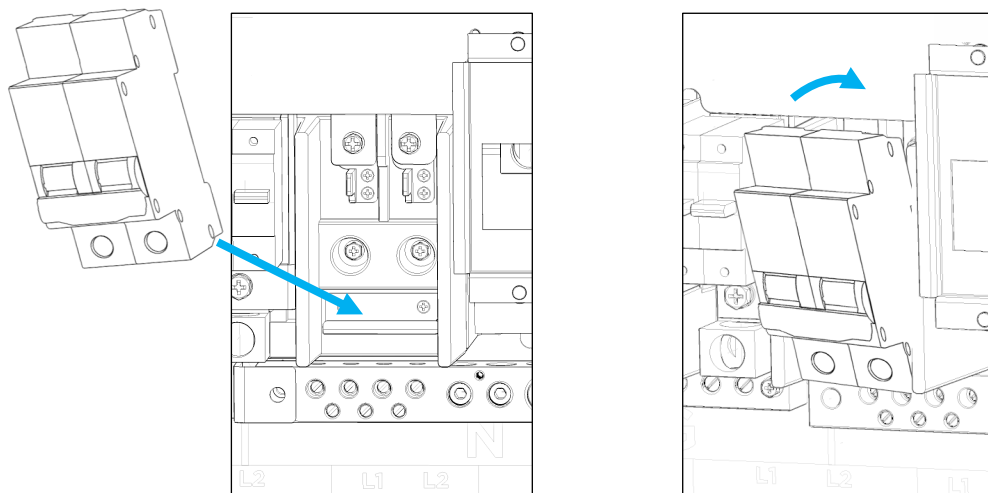

Optional Main Breaker Installation:

1. Remove the internal orange cover by first removing the two nuts using a 7mm socket and then the four screws using a Phillips screwdriver. Next, lift the cover out of the unit.



2. After removing the inside cover, locate the lugs for both line 1 and line 2 (outlined with a dashed line). Unscrew the fastener that holds each lug in place, and then remove each lug.

Remove the small Phillips head screw (circled) and set it aside. This screw is reinstalled in a later step with the main breaker.

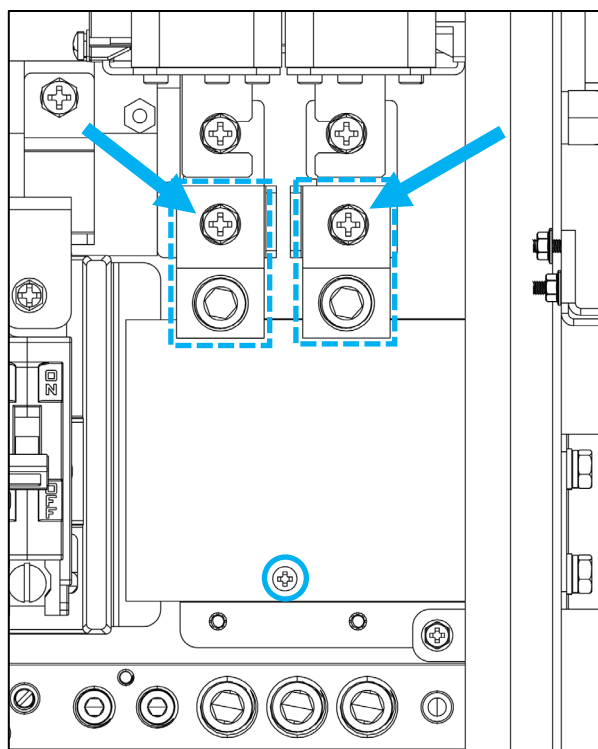

3. Ensure the anti-twist plates are correctly positioned to facilitate the installation of the Eaton main breaker. The supported orientations of the plates (in gray) are displayed below. If the anti-twist plates require adjustment, first remove the two screws securing the fuses and plates. Then adjust the orientation to a supported orientation and re-torque the screws to 80 in-lbs (9 Nm).

Supported Configurations:

- a. Anti-twist plates with edges pointing downward and inward.

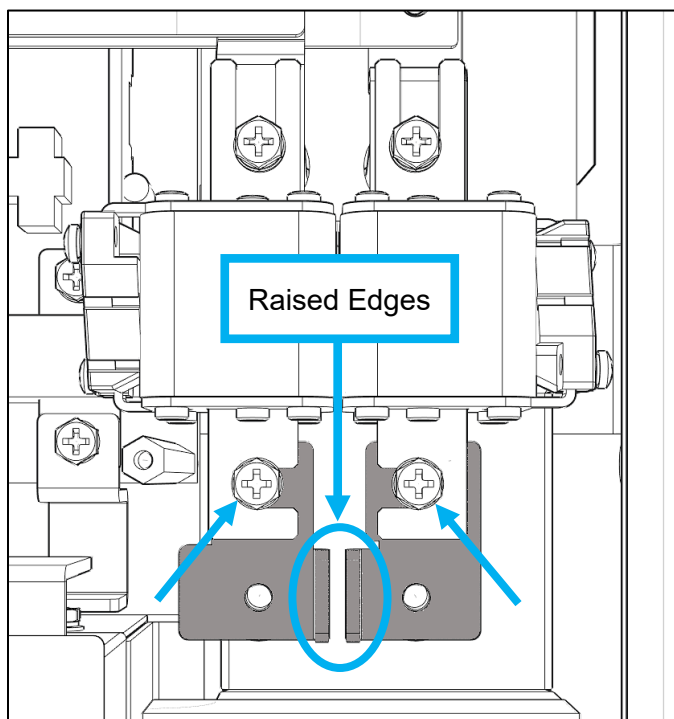

- b. Anti-twist plates with raised edges pointing upward, in both variations.

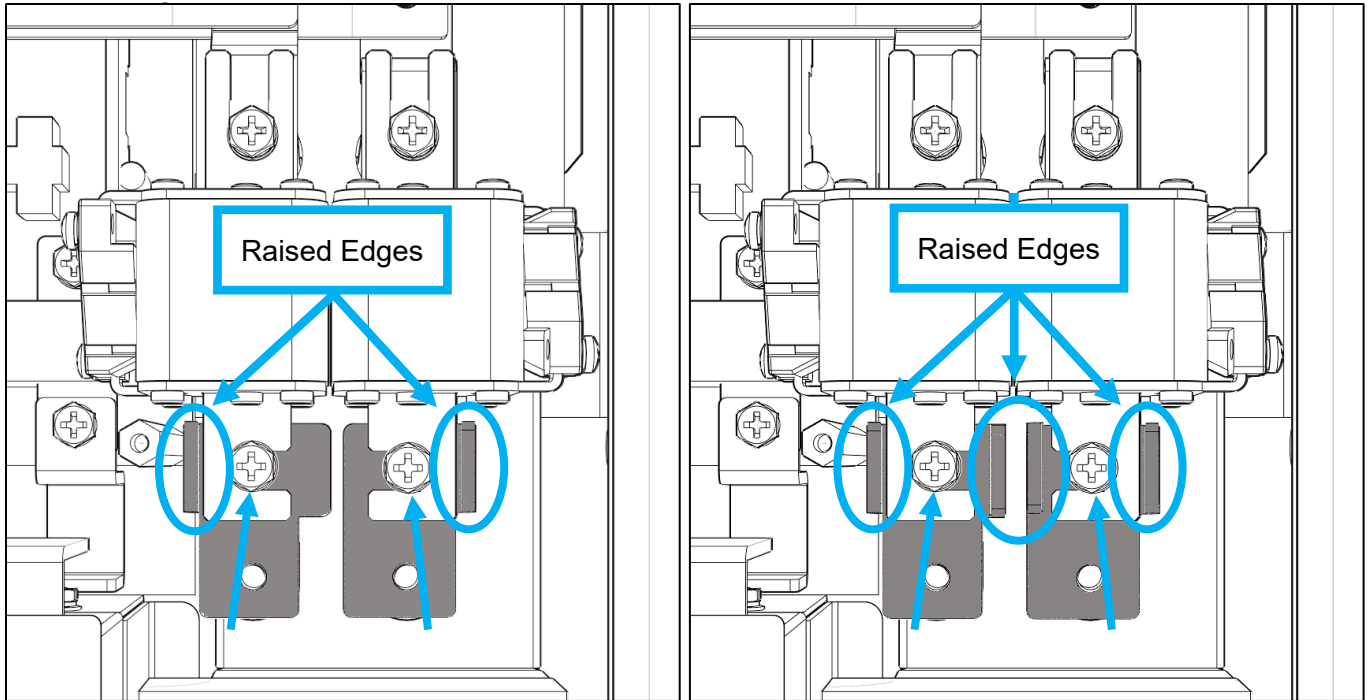

4. Before installing the breaker, adjust the position of the insulation sheet by moving the end to the right side.

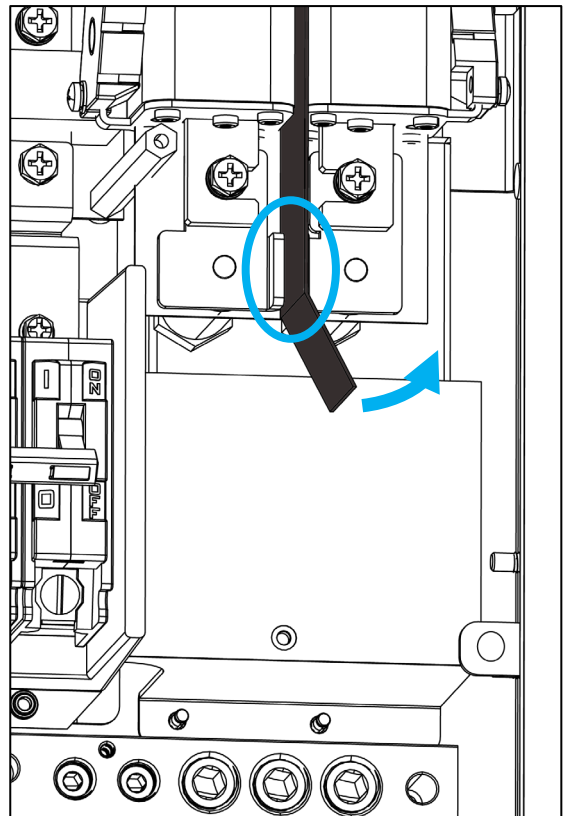

5. Install the 200A Eaton CSR2200N (CSR25K) breaker by sliding it into place, aligning the bolt holes in the breaker lugs to the holes on the busbar.

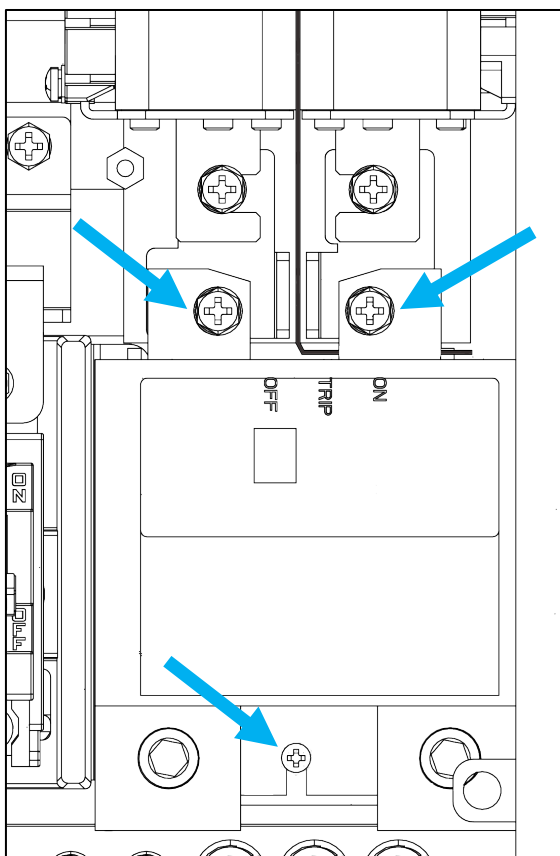
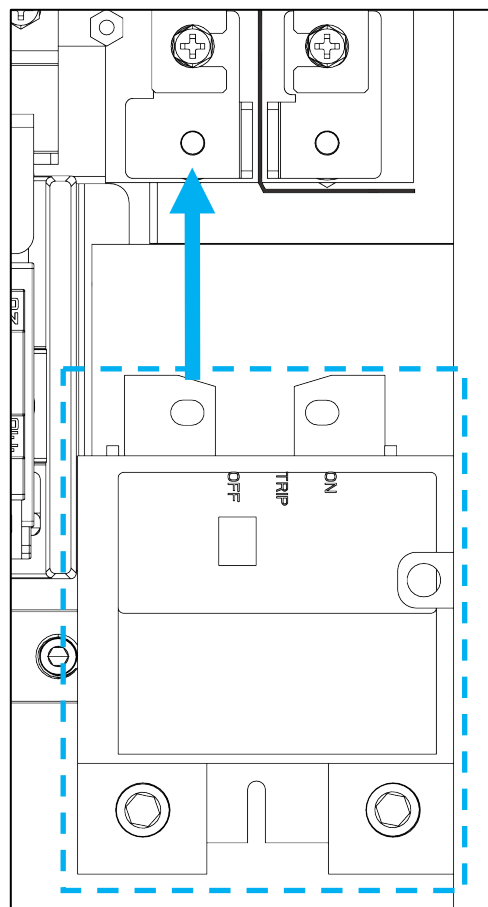

6. Using a 10 mm socket, install the two M6 screws in the busbar, then install the M4 screw that holds the opposite end of the breaker in place.

Tighten the M6 screws to 80 in-lbs. (9Nm) and the M4 screw to 10 in-lbs. (1.2Nm).

When installing the conductors to the main breaker terminals, use a 1/4-inch hex wrench and torque to 250 in-lbs. (28Nm).

7. Install the orange inner cover plate removed in step 2.

6.5 INSTALL CABLES

Use the information in this section for guidance on connecting the AC wiring. Using a multimeter, verify that each wire does not carry voltage or current before making any connections to the GridBOSS.



WARNING:

Use **ONLY COPPER WIRE** for **ALL** GridBOSS connections! Failure to use copper wire could result in equipment damage, as the unit has not been approved to accept other types of wiring. This includes connections to all GridBOSS lugs and breakers, regardless of the breaker's rating.



IMPORTANT:

The GridBOSS is Service Entrance Rated and certified under UL869A only when installed with a 200A Eaton CSR2200N (CSR25K) breaker.

SYSTEM GROUND

The ground busbar supports connecting the GridBOSS to the building's equipment grounding system and to the building's grounding electrode system if it is used as service entrance equipment. The ground cable should be installed first to provide a solid ground during the wiring installation process.

LUG COUNT	SUPPORTED WIRE SIZE	MAX. TORQUE VALUE	HEX TOOL SIZE
8	14 – 4 AWG	35 in-lbs. (4.5Nm)	1/8 inch
6	4 – 2 AWG	50 in-lbs. (5.6Nm)	5/32 inch

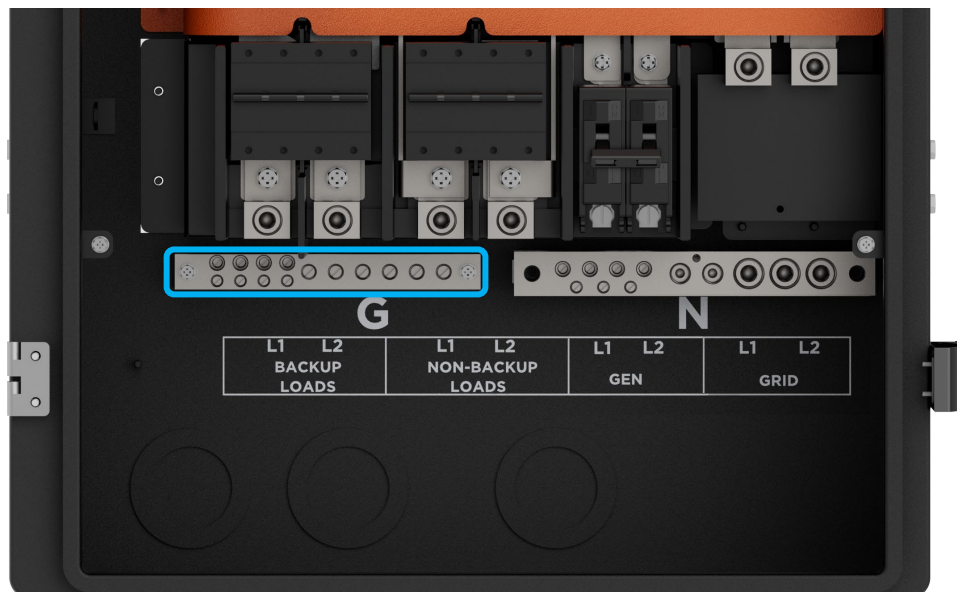

NEUTRAL WIRING AND BONDING

The neutral busbar supports the interconnection of the neutral wires within the electrical system.

LUG COUNT	SUPPORTED WIRE SIZE	MAX. TORQUE VALUE	HEX TOOL SIZE
7	14 – 4 AWG	35 in-lbs. (4Nm)	1/8 inch
2	3 – 2/0 AWG	94 in-lbs. (10Nm)	3/16 inch
3	2/0 AWG – 250 kcmil	275 in-lbs. (31Nm)	5/16 inch (8 mm)

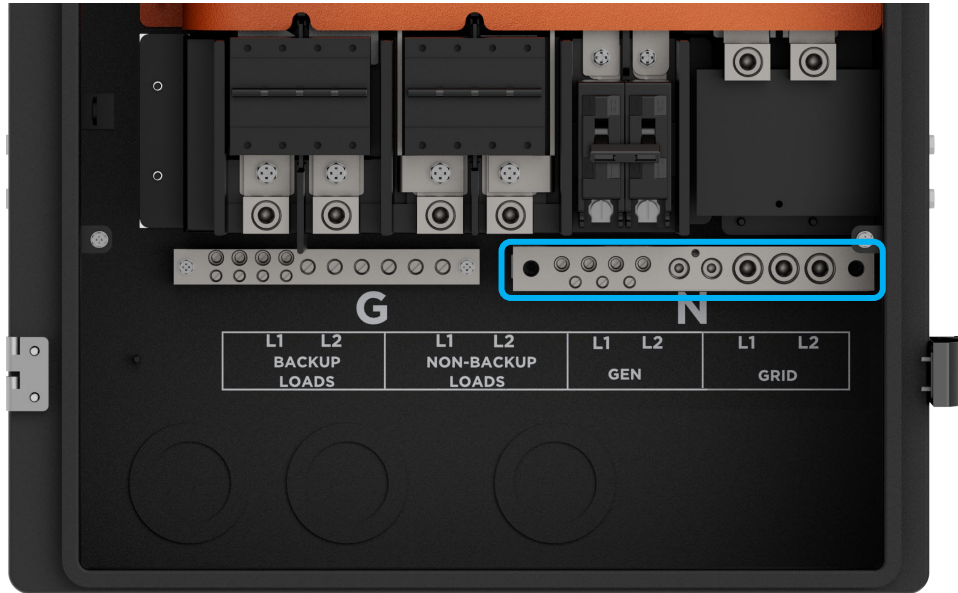

NEUTRAL GROUND BOND

The unit ships with a neutral-ground bonding jumper (bracket) that connects the ground bar to the neutral bar. This should only be attached if the GridBOSS is the first service disconnect, as there can only be one neutral bond connection in the electrical system. Use the M6-1x38 mm screw included with the unit packaging to attach the jumper to the neutral bar side.

For example, the bonding jumper would most commonly be used if the GridBOSS is installed directly after the power meter and is set up as the first service disconnect. In this configuration, the 200A Eaton CSR2200N (CSR25K) breaker must be installed in the GridBOSS.

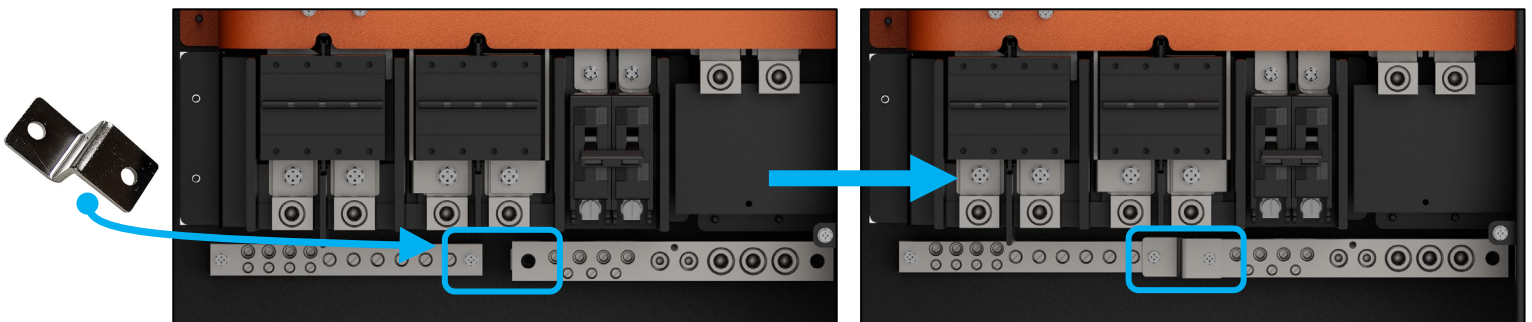

If a first service disconnect is already installed after the power meter, the GridBOSS will be attached in series with the existing first service disconnect. In this case, the bonding jumper should not be used.

If there are questions concerning the neutral ground bond, contact a licensed electrician for assistance.



IMPORTANT:

The system should have one and only one neutral-ground bond. This is typically the main bonding jumper at the first service entrance disconnect.

GRID PORT

The grid input supplies power to the GridBOSS in a grid-assisted configuration. There are two configuration options when connecting to the grid. The first option uses lugs, which are factory installed. The second option uses the 200A Eaton CSR2200N (CSR25K) breaker, which is optional and must be purchased separately. To install the 200A Eaton breaker, follow the steps in section 6.4.

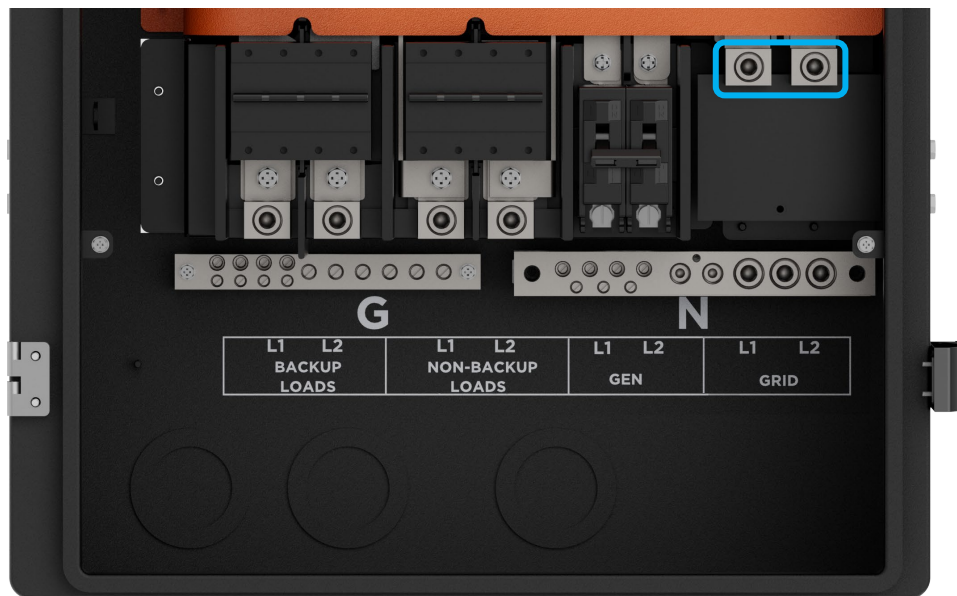

Reference the table below for wire size and torque recommendations when connecting the grid port wiring.

BREAKER SIZE	MAX. SUPPORTED BREAKER SIZE	SUPPORTED WIRE SIZE	MAX. TORQUE VALUE	TOOL SIZE
Lugs	-	4 – 2/0 AWG	110 in-lbs. (12Nm)	5/16 in. (8 mm)
		3/0 AWG – 250 kcmil	275 in-lbs. (31Nm)	5/16 in. (8 mm)
200A (optional)	200A	4/0 AWG – 300 kcmil	250 in-lbs. (28Nm)	1/4-inch hex

GENERATOR PORT

GridBOSS can utilize supplemental 240VAC generator power for backup and battery charging in the event of a grid failure. When the grid power goes down, the generator port can supply power to the backup port, the hybrid ports, and the configured smart ports. To support Automatic Generator Start (AGS), the GridBOSS has a 2-wire start/stop terminal for controlling 2-wire start capable generators.

For optimal performance, it is highly recommended that a generator has a Total Harmonic Distortion (THD) of less than 12%. To achieve a lower THD value, the generator should be sized by at least 1.5x the total output of all inverters. This will allow for powering loads and charging batteries.

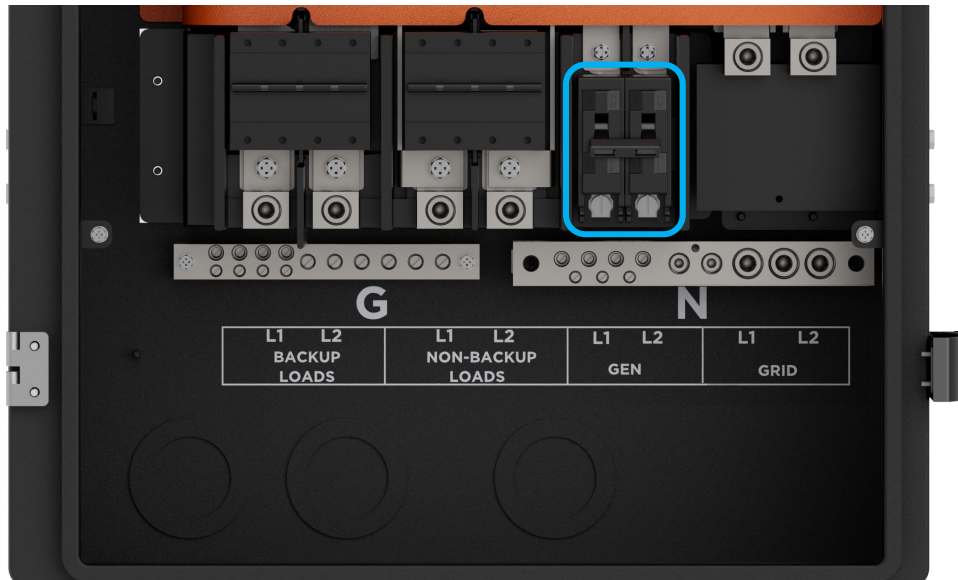

NOTE:

When operating a hybrid inverter with the GridBOSS, all generator support will come directly through the GridBOSS generator port. The generator port on each hybrid inverter must not be used.

Reference the table below for wire size and torque recommendations when connecting the generator port wiring.

SUPPORTED BREAKER SIZE	SUPPORTED WIRE SIZE*	MAX. TORQUE VALUE
80A, 100A, 125A	4 – 2/0 AWG	see torque value printed on breaker
30A, 40A, 60A	10 – 4 AWG	

*Size wire according to breaker amperage/system needs

GENERATOR OPERATION

The attached generator can only be started when the grid is lost, and the generator is wired for a 2-wire stop/start using the “Dry 1” contacts on the communications board. The internal grid relay and the internal generator relay cannot be closed simultaneously to prevent the generator output from sending power to the grid.

The GridBOSS should use start/stop relay 1 in the normally open connection. Start/stop relay 1 can be controlled manually or by battery SOC/voltage logic within the EG4® Monitor Center. The generator can also be configured with warm-up, cool-down, and exercise time.

The GridBOSS generator relay can only be closed after the start/stop relay 1 is closed. When start/stop relay 1 is closed, the GridBOSS must wait until the generator can supply stable output power. This wait time is configured using the generator warm-up time setting in the EG4 Monitor Center. Once the generator warm-up time is complete, the GridBOSS will close the generator relay. Before the generator can be safely powered off, it must complete its cool-down time. Once the cool-down time is complete, the GridBOSS will open the generator relay and start/stop relay 1. The Start/Stop relay 1 connection is labeled Dry 1 on the GridBOSS cover plate. The Dry 2 connections are currently unused and reserved for future use.

Generator 2-Wire Start Specifications

- Maximum Voltage 30VDC, 277VAC
- Maximum NO Contact Current: 5A
- Maximum NC Contact Current: 3A

GridBOSS Communications Board

- COM1 and NC1 are a set of normally closed switches
- COM1 and NO1 are a set of normally open switches
- COM2 and NC2 are a set of normally closed switches
- COM2 and NO2 are a set of normally open switches

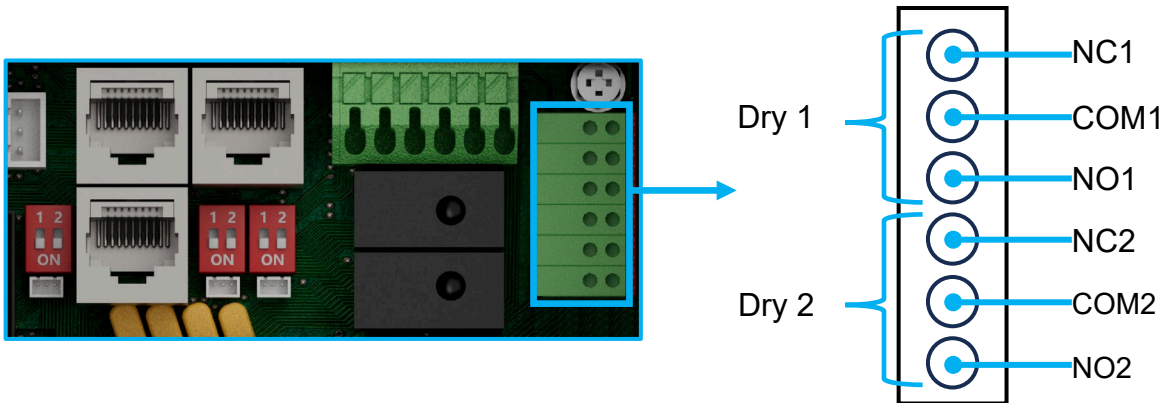

NON-BACKUP LOADS PORT

The non-backup loads port is used to pass power from the Grid input to loads that either do not require backup or are intentionally omitted from the backed-up loads to prevent inverter overload during an outage. Loads connected to this port will not have power during a grid outage. Using smart ports may be a better option for loads that might overload the inverter upon start-up but have the advantage of being backed up if there is sufficient power from the inverters during a grid outage.

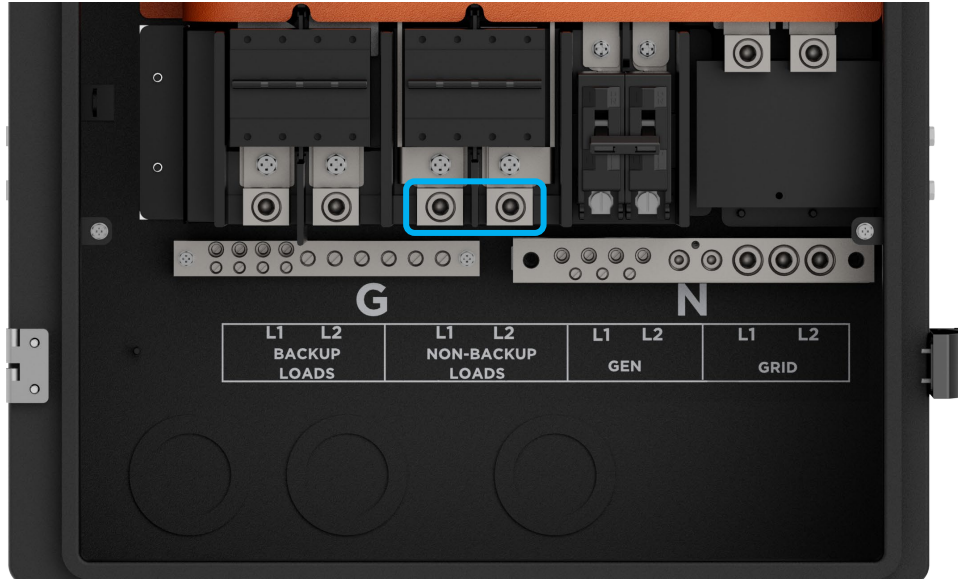

NOTE:

The breaker above the non-backup port is not connected to the non-backup port lugs and is not used by the non-backup port. This breaker is used when activating manual bypass mode.



CAUTION:

The non-backup port is not controlled by a breaker or relay and will always receive current if the GridBOSS is supplied with grid input.



WARNING:

*The non-backup port does not have built-in overcurrent protection at the port output. An external breaker **MUST** be installed with the proper amperage rating to protect the wire size used. The breaker cannot exceed a 200A rating.*

Reference the table below for wire size and torque recommendations when connecting the non-backup port wiring.

BREAKER SIZE	MAX. SUPPORTED BREAKER SIZE	SUPPORTED WIRE SIZE	MAX. TORQUE VALUE	TOOL SIZE
Lugs	Lugs only	4 – 2/0 AWG	110 in-lbs. (12Nm)	5/16 in. (8 mm)
		3/0 AWG – 250 kcmil	275 in-lbs. (31Nm)	5/16 in. (8 mm)

BACKUP LOADS PORT

The backup loads port provides power to any panel that needs to be backed up by the EG4® Energy Storage System (ESS). This could be the home's main breaker panel, a critical loads subpanel, or any combination of main panels and subpanels.

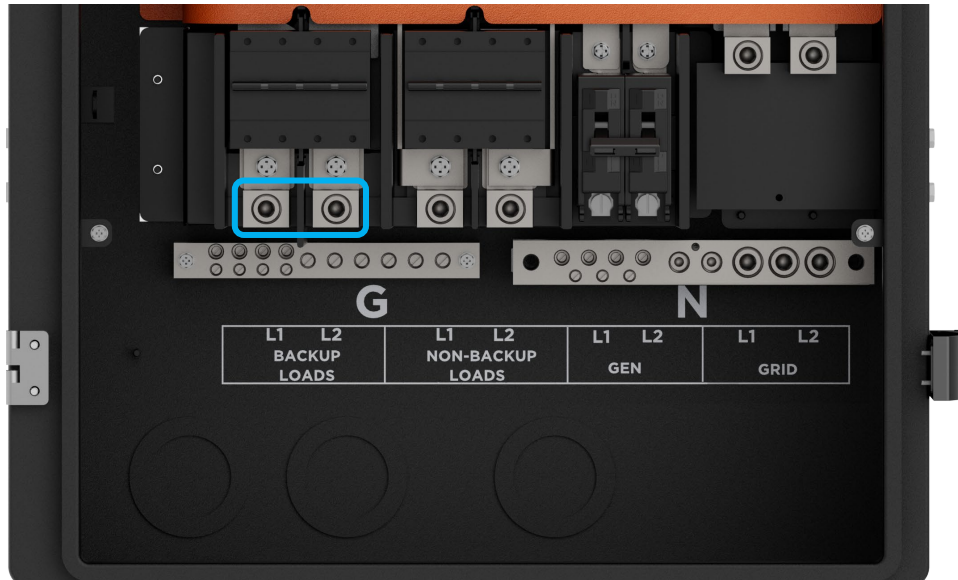

CAUTION:

The backup loads port cannot connect to a load panel that is receiving power from an additional source, such as a utility, generator, or AC-coupled solar, unless a manual transfer switch is used.



IMPORTANT:

When operating an EG4 hybrid inverter with the GridBOSS, the inverter's load port should remain unused and be in the off position. The inverter's grid port supports both input and output based on the inverter's settings. Critical loads will be cabled to and powered by the backup loads port on the GridBOSS.

Reference the table below for wire size and torque recommendations when connecting the backup port wiring.

MAX. SUPPORTED BREAKER SIZE	SUPPORTED WIRE SIZE	MAX. TORQUE VALUE	TOOL SIZE
200A (preinstalled)	4 – 2/0 AWG	110 in-lbs. (12Nm)	5/16 in. (8 mm)
	3/0 AWG – 250 kcmil	275 in-lbs. (31Nm)	5/16 in. (8 mm)

HYBRID INVERTER PORTS

The GridBOSS hybrid ports are compatible with supported EG4® hybrid inverters. When cabling the AC connection to the hybrid inverter, only connect the inverter's grid port to the GridBOSS hybrid port. Refer to the table below for a list of supported EG4 hybrid inverters.

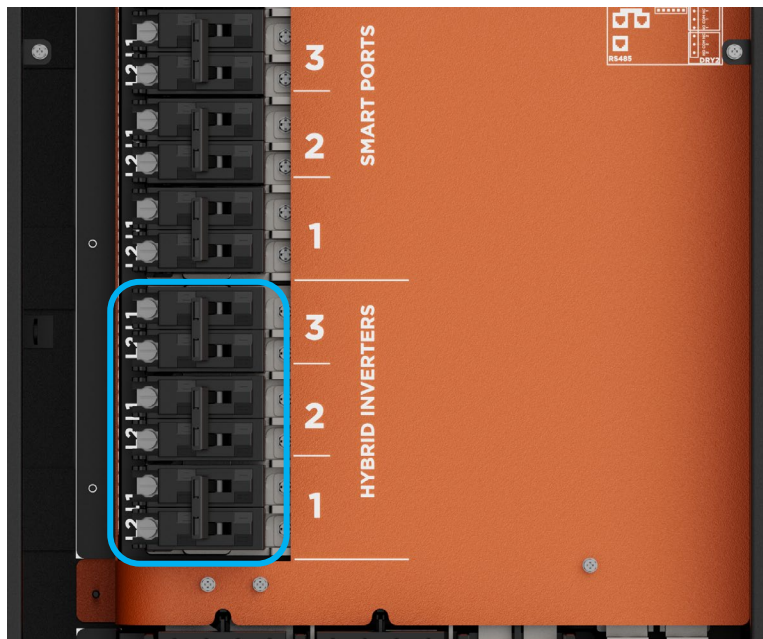

WARNING:

- **The only inverters that can be connected to the hybrid ports are the 12kPV, 18kPV, FlexBOSS18, and FlexBOSS21. DO NOT connect any other inverters to the hybrid ports, as this could damage the inverter connected to the GridBOSS.**
- **Use the proper breaker sizing and wiring requirements described below for each hybrid inverter. Do not use a breaker rated higher than what is supported; this could damage the equipment.**



IMPORTANT:

When operating a hybrid inverter connected to the GridBOSS, the inverter's load port must be unused and turned off. The inverter's grid port supports input and output power based on the inverter's settings.

Reference the table below for wire size and torque recommendations when connecting the hybrid port wiring.

HYBRID PORT	SUPPORTED INVERTER MODEL	SUPPORTED BREAKER SIZE	SUPPORTED WIRE SIZE*	TORQUE VALUE
1 – 3	12kPV	50A	6 AWG	see torque value printed on breaker
	18kPV FlexBOSS18	70A	4 AWG	
	FlexBOSS21	90A	2 AWG	

*Size wire according to breaker amperage/system needs

SMART PORTS

Smart ports are designed to power smart loads or accept AC-coupled inverter inputs. They are controlled by an internal relay configured in the EG4® Monitor Center. Each port can also be manually switched on or off using the breaker. Each smart port is individually configured and has different load specs, as outlined in the table below.

When using smart ports configured for smart loads, the attached devices can be powered on or off according to grid presence, Time of Use (TOU), battery State of Charge (SOC) or voltage, and PV state. When using the smart port with an AC-coupled inverter, additional power can be injected into the ESS system from the PV array connected to the inverter.

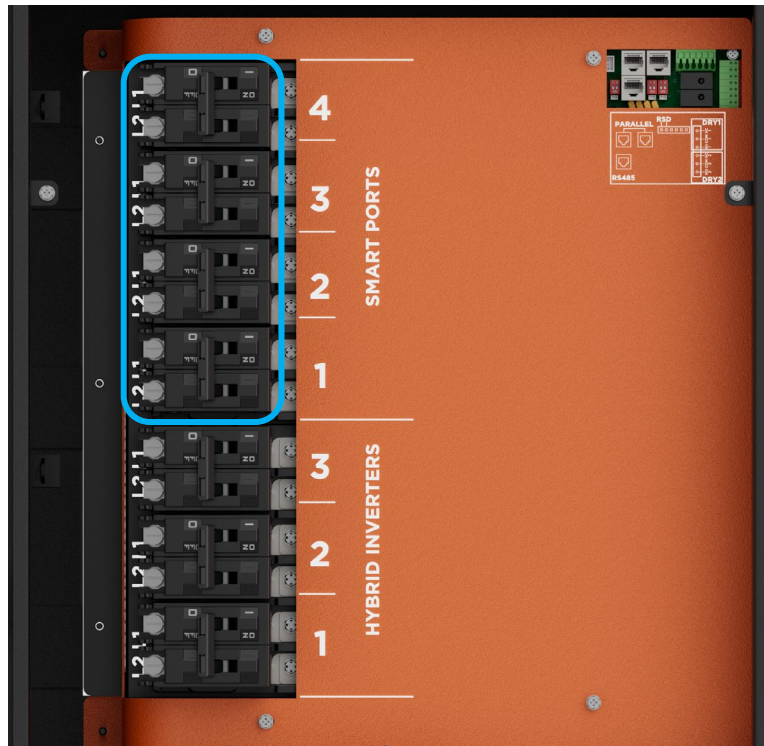

NOTE:

When operating a hybrid inverter with the GridBOSS, smart port functionality is moved from the hybrid inverter to the GridBOSS. All devices that connect through a smart port must be cabled directly to a GridBOSS smart port. Select GridBOSS in EG4® Monitor Center when configuring a smart port.

Refer to the table below for wire size and torque recommendations, which vary depending on the type of wire and connection.

SMART PORT #	SUPPORTED BREAKER SIZES	SUPPORTED WIRE SIZE*	MAX TORQUE VALUE
1	90A, 100A, 125A	2 – 2/0 AWG	see torque value printed on breaker
1 & 2	70A, 80A	4 – 3 AWG	
1 – 4	30A, 40A, 50A, 60A	10 – 4 AWG	

*Size wire according to breaker amperage/system needs

RAPID SHUTDOWN & ESS DISCONNECT

GridBOSS supports a rapid shutdown system that complies with the 2017 and 2020 NEC 690.12 requirements, as well as an ESS Disconnect that complies with NEC 706.15 requirements. When used, the rapid shutdown switch on the right side of the GridBOSS will initiate total system shutdown, including the inverters, backed-up loads, smart ports, supported batteries, and PV (if properly equipped). The only port that will remain powered by the grid is the non-backup loads port. When connecting the GridBOSS to EG4® hybrid inverters, the RSD wiring only needs to be connected to the master inverter. An external RSD/ESS initiator is installed inline between the inverter and the GridBOSS, as shown in the image below.



NOTE:

When using supported EG4 batteries in closed-loop communications with the inverter, the RSD also initiates ESS Disconnect.

The system can utilize an external RSD/ESS initiator (switch) placed near the service entrance in full view of first responders. If an external RSD/ESS initiator is installed in series with the GridBOSS to Inverter wiring, normally closed contacts must be used for emergency shutdown.

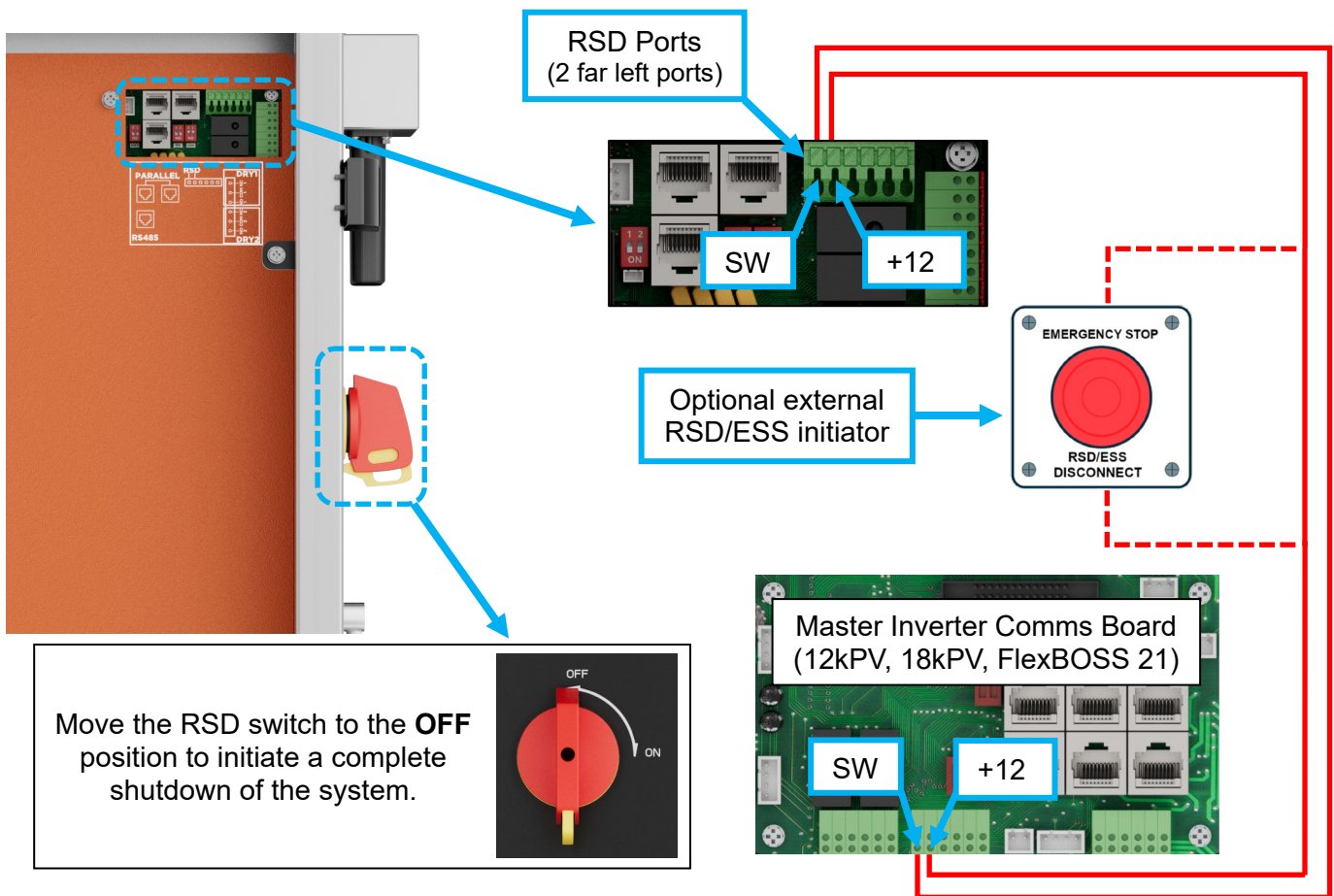

Move the RSD switch to the **OFF** position to initiate a complete shutdown of the system.

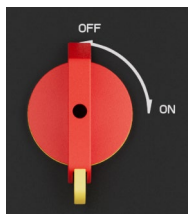

Refer to the Hybrid Inverter RSD Wiring Guide for more information.

If installed, remove the existing jumper wire between the SW and +12 ports on the master inverter only. All subsequent inverters must have the jumper installed.

REPLACING THE CABLE BOX COVER

Before replacing the cable box cover, remove any knockouts where a breaker was installed. The knockouts are designed to be rocked back and forth until the small connection point between the knockout and the cover is broken, allowing the knockout to be removed. Install the grid and generator cover plate if breakers are not installed in those areas. Before powering up the unit, reinstall the cable box cover. The image below shows all the hybrid and smart port breakers installed. No main or generator breaker is installed, so the cover plates are attached to the cable box cover.

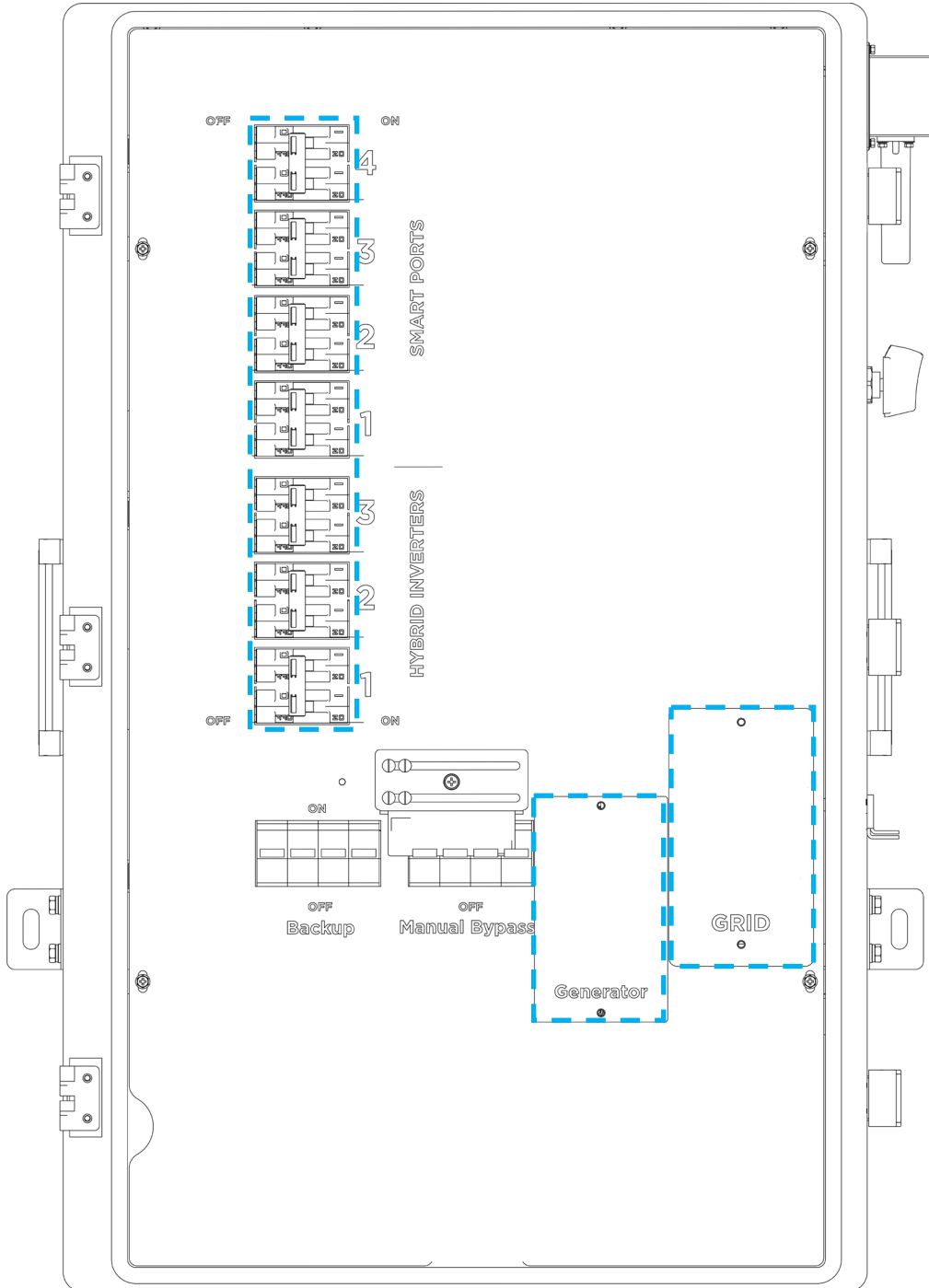

6.6 CONFIGURE THE HYBRID INVERTERS

As best practice, configure the hybrid inverter(s) before configuring the GridBOSS. When configuring each inverter, note the following:

- During the initial configuration, use only battery power for the inverters. The GridBOSS should remain powered off. The inverter grid port cannot be connected directly to the grid.
- Do not install the inverter's CT clamps since GridBOSS has internal CT clamps.
- Verify that the battery or battery bank and the PV array are properly connected to the inverter(s) and are functioning correctly.
- If using multiple inverters, verify they are set up in a functioning parallel configuration.
- **DO NOT** connect the inverter's load port to GridBOSS. The inverter's load port must remain in the off position.
- **DO NOT** connect anything to the inverter's generator port (if equipped). The inverter's generator breaker should remain in the off position. All smart load, AC couple, and generator functionality will be connected to and configured on the GridBOSS.
- Install at least the minimum firmware required on each inverter, as shown in the chart below.

Refer to the inverter documentation linked below for detailed instructions on installation and configuration guidance:



12kPV
Inverter



18kPV
Inverter



FlexBOSS18
Inverter



FlexBOSS21
Inverter



NOTE:

Verify that each hybrid inverter has at least the minimum required firmware installed to support connectivity with the GridBOSS. Each inverter uses system firmware. The 12kPV and 18kPV also use LCD firmware, which supports the front-panel LCD screen. For more information on updating firmware, see section 10 of this manual.

INVERTER	MIN. SYSTEM FIRMWARE	MIN. LCD FIRMWARE
12kPV	FAAB-1E1E	V18
18kPV	FAAB-1E1E	V18
FlexBOSS18	FAAB-2021	N/A
FlexBOSS21	FAAB-1E1E	N/A

6.7 CONFIGURE GRIDBOSS

Before configuring the GridBOSS, verify the following:

- The inverter(s) are fully configured with at least the minimum firmware required to operate with the GridBOSS. This should have been completed in the previous section.
- Each hybrid inverter is powered **off**.
- All GridBOSS breakers are in the **off** position.
- If a main breaker is not installed in the GridBOSS, verify that the source providing power to the GridBOSS is in the off position.
- If the non-backup port is connected to an electrical panel, verify that the breaker in that panel is in the off position. **DO NOT** switch on the electrical panel main breaker until the GridBOSS is completely configured.
- Before proceeding with the steps below, use a multimeter to verify that there is no voltage/current present at each GridBOSS lug and breaker.

1. Connect the communication cable between the GridBOSS and the inverter(s) using the images below as reference.
 - GridBOSS DIP switches should remain in the down position (ON) as shipped from the factory. Also, note that the GridBOSS DIP switch is flipped 180 degrees compared to the inverters. Down is ON and up is OFF.
 - A single inverter or the master inverter DIP switches should be in the up position (ON).
 - All slave inverters should be in down position (OFF).



NOTE:

If the communications cable needs to be replaced or a longer cable is required, use a CAT5 or higher specification straight-through network cable in the 568B format. The communications cable cannot be longer than 260 feet (80 meters).

GridBOSS with One Hybrid Inverter

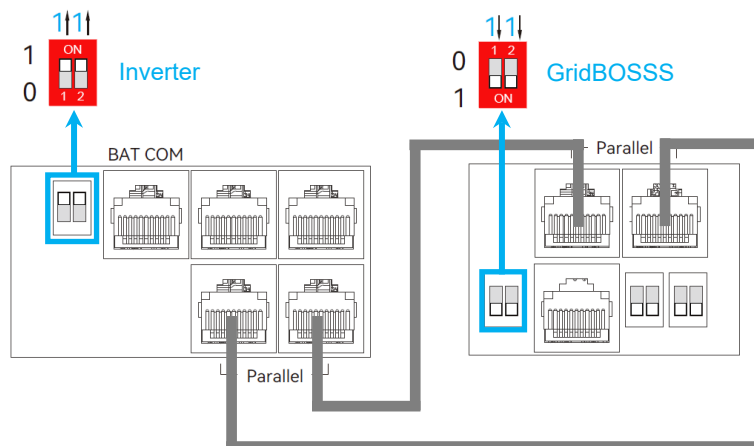

GridBOSS with Two Hybrid Inverters

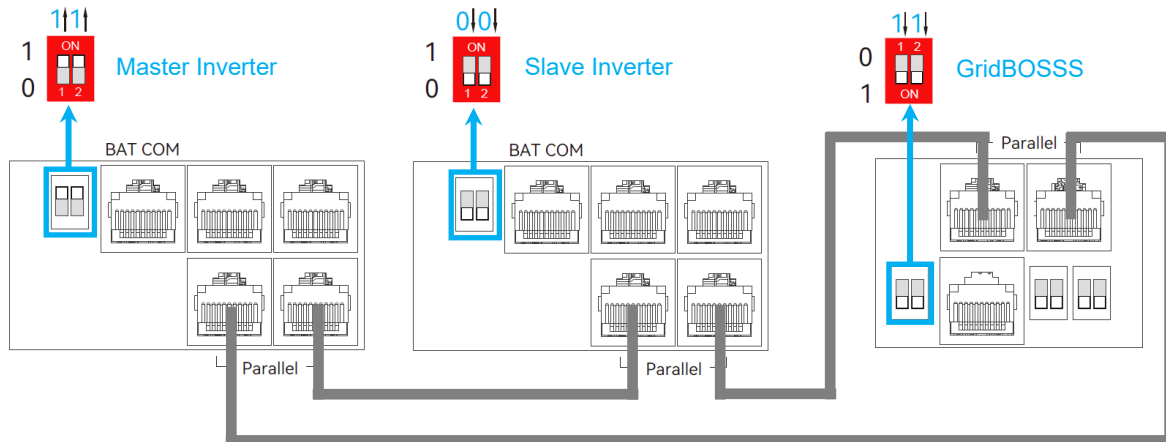

GridBOSS with Three Hybrid Inverters

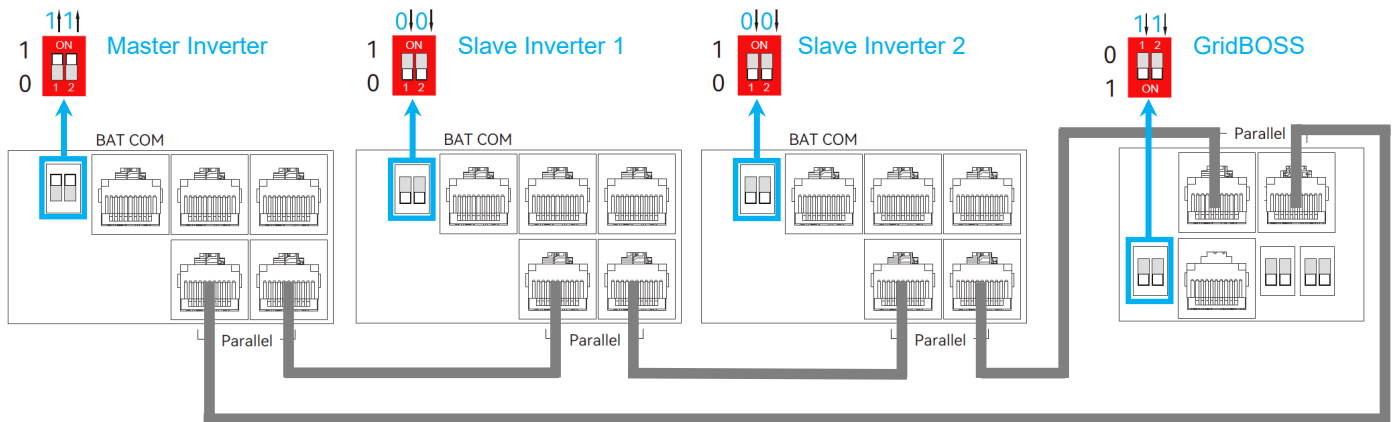

2. Power on the inverter(s), starting with the master in a parallel configuration. The inverters should only be powered by a battery or battery bank.
3. Enable the “Grid Boss” setting on the inverter (master inverter in a parallel configuration). The 12kPV and 18kPV can be set up using their front LCD panel. When setting up the FlexBOSS inverters, use the EG4® Monitor Center website or the optional EG4 FlexBOSS Screen Kit (sold separately).
 - LCD Panel: Navigate to the Advanced page and select the “Grid Boss” setting, and then select the “Set” button to save the settings.

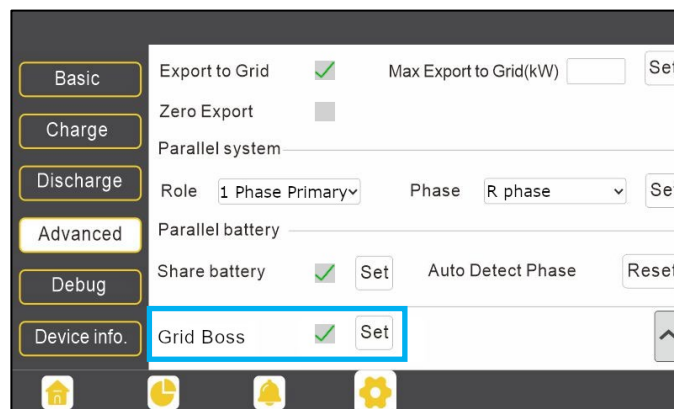

- **Monitor Center:** Select the “Maintenance” tab and then select “Working Mode” in the upper right area of the screen. Expand “Application Setting” and then select “Advanced Settings.” Select “Enable” next to the “Grid Boss Enable” setting.

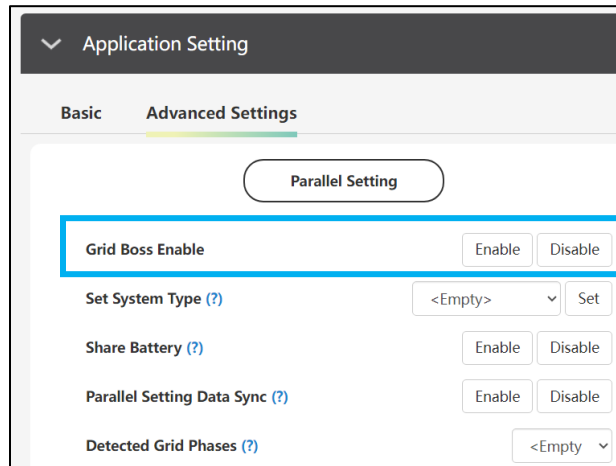

4. Switch the GridBOSS hybrid inverter breaker(s) to the on position. This should power on the GridBOSS using the inverter’s grid port as the power source. If the “Grid Boss Enable” setting was not enabled in the previous step, the GridBOSS will not power on.
5. Verify that the GridBOSS hybrid LED is illuminated and displays a solid green light.
6. Verify that all grid settings are configured appropriately based on whether grid sell-back is enabled or disabled. All grid sell-back functionality is configured within the inverter settings. The FlexBOSS inverters will require the use of the EG4 Monitor Center, mobile app, or an external EG4 FlexBOSS Screen Kit.
7. Enable grid input to the GridBOSS by turning on the grid breaker (if equipped) or the breaker providing grid access.

6.8 VERIFY CONFIGURATION

1. Visually inspect the GridBOSS’ front panel LEDs. The “Grid” and “Hybrid” LEDs should be solid green. If a flashing LED is present, refer to Section 11 for additional troubleshooting information.
2. Verify inverter settings using the LCD or Monitor Center:

Using the LCD Panel:

Verify the settings shown below using the inverter’s LCD panel. The inverter will also display a small green “Grid Boss” icon on the bottom left of the home page.

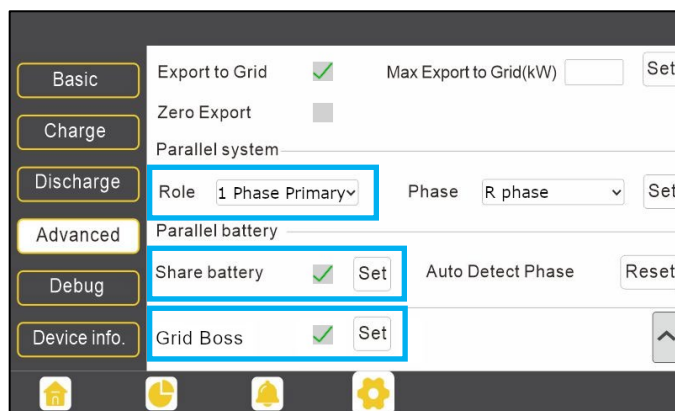

- **Role:** Verify the GridBOSS has only **ONE** master inverter. The master inverter should be set to “1 Phase primary,” and all other inverters should be set to “Slave.” Remember to press the “Auto Detect Phase” reset button if any changes are made to the parallel settings.
- **Share Battery:** Select “Share Battery” if the inverters share a single battery bank. Do not select “Share Battery” if each inverter is connected to a dedicated battery.
- **Grid Boss:** Verify “Grid Boss” is checked for all parallel inverters connected to GridBOSS hybrid ports.



NOTE:

When a 12kPV or 18kPV inverter is connected to the GridBOSS, the inverter’s main LCD page displays the total power values for the entire system, which differ from those of parallel systems without the GridBOSS. “Grid Power” on the main page equals the GridBOSS grid power value. “Home Load” shows all the load power going through the GridBOSS. “AC Couple” power shows the power of all AC couple smart ports.

Using Monitor Center:

Select the “Maintenance” tab and then select “Working Mode” in the upper right area of the screen. Expand “Application Setting” and then select “Advanced Settings.” Select “Enable” next to the “Grid Boss Enable” setting.

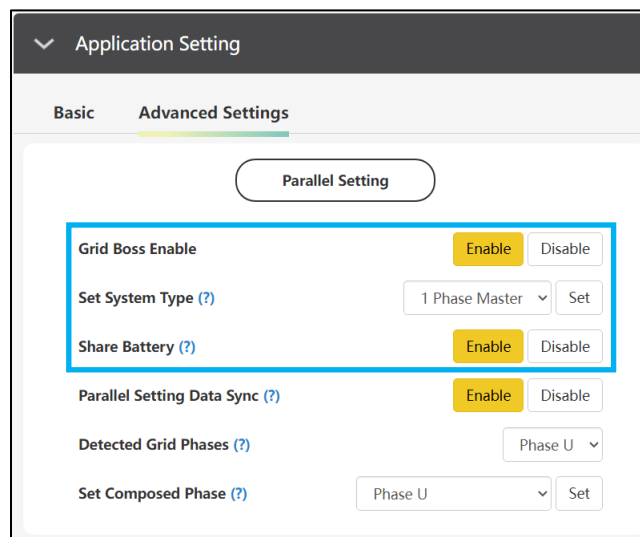

- **Grid Boss Enable:** Verify “Grid Boss Enable” is enabled for each inverter connected to a GridBOSS hybrid port.
 - **Set System Type:** Verify that GridBOSS has only ONE master inverter. The master inverter should be set to “1 Phase Master,” all other inverters should be set to “Slave.”
 - **Share Battery:** Select “share battery” if the inverters share a single battery bank. Do not select “share battery” if each inverter is connected to a dedicated battery.
3. Check each inverter and verify there are no errors or warnings. If there are any issues, refer to the inverter model documentation for additional troubleshooting information.
 4. The system is ready for use and can be further configured with advanced features such as auto generator start, smart loads, and AC coupling.

7. SYSTEM OPERATION & CONFIGURATION EXAMPLES

To power up and be ready for operation, the GridBOSS must be set up with at least one powered input. The input can be from the grid, a hybrid inverter, or a generator. The GridBOSS is a power distribution unit that controls power flow using internal relays and software. When configuring settings for the inverters or GridBOSS, select the corresponding serial number in the EG4® Monitor Center or the mobile app.

7.1 HYBRID INVERTERS

When using hybrid inverters with GridBOSS, the settings for grid interactivity are configured at the inverter level. GridBOSS can only control the ports within the chassis by opening or closing each individual port relay. The inverters communicate with the GridBOSS via a communication cable, exchanging configuration settings, currents, voltages, and any other necessary data to direct power output.

No Grid Sell Back

In this example, “Grid Sell Back” is disabled within the inverter’s settings. This supports grid assist for powering backup loads, smart loads, charging battery storage, and non-backup loads.

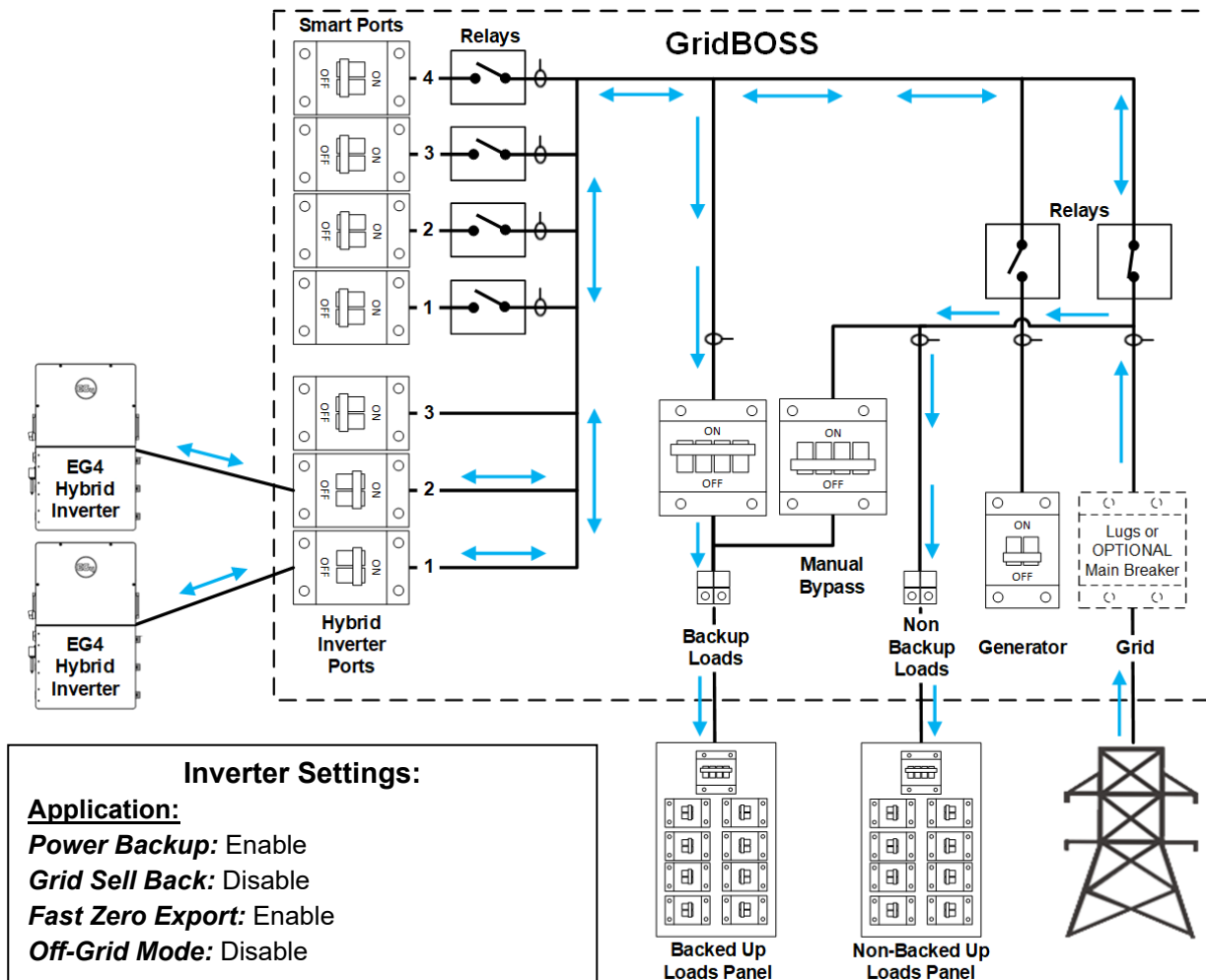

Grid Sell Back

In this example, "Grid Sell Back" has been enabled within the inverter settings. When the inverter provides power to the loads, the priority is to power the backup loads first; any excess power will be allocated to the non-backup loads. Power will also be supplied to the smart loads, where the priority is set within the smart load settings. To include battery power with grid sell-back, enable "Forced Discharge Enable." Enable "PV Sell To Grid (Comp. w/ NEM3.0)" to only use PV with grid sell-back. To maximize grid sell-back, consider load shedding non-critical loads using the smart ports. The grid will assist in providing power to non-backup loads, backup loads, and the smart ports as needed.

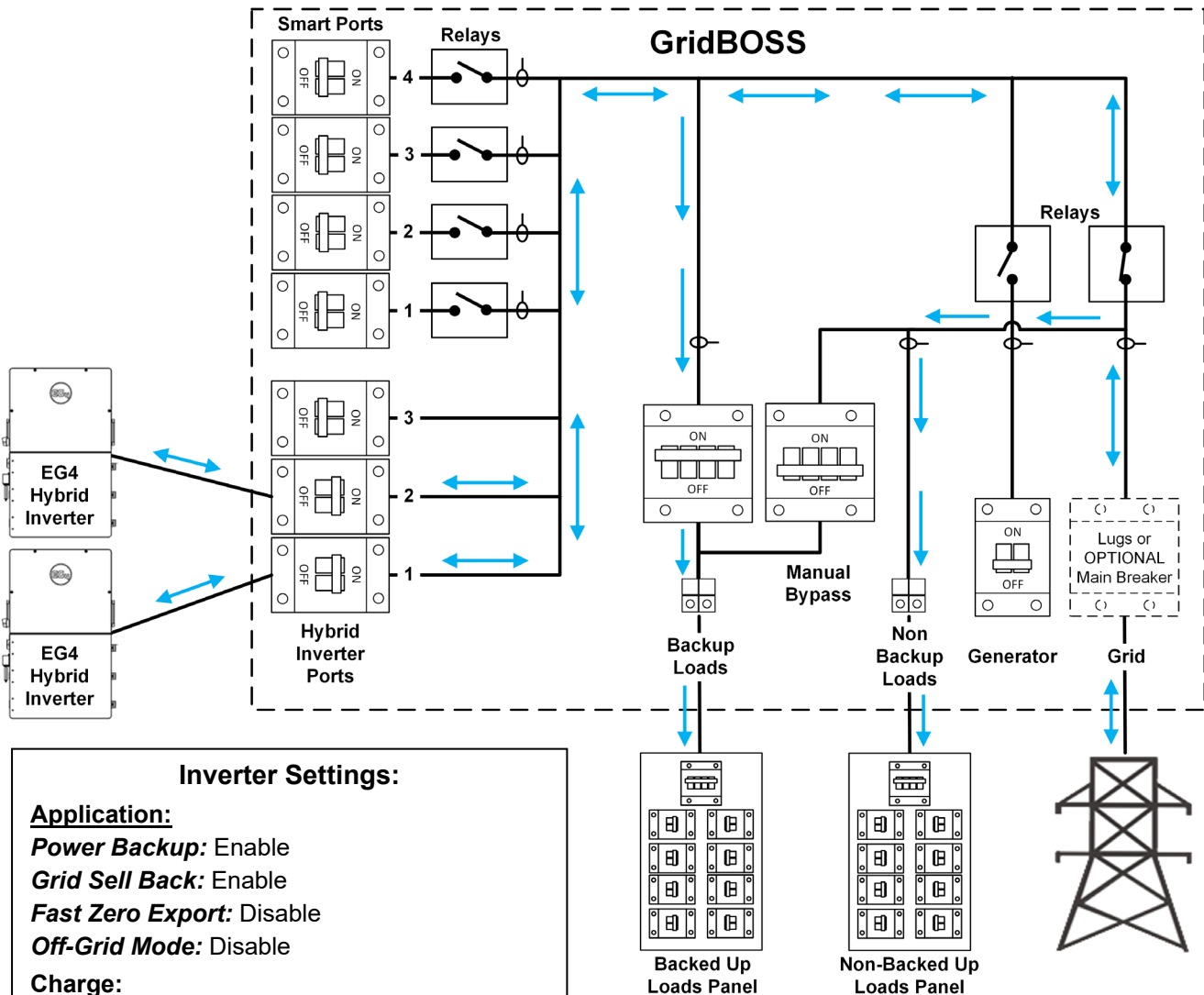

Inverter Settings:

Application:
Power Backup: Enable
Grid Sell Back: Enable
Fast Zero Export: Disable
Off-Grid Mode: Disable

Charge:
AC Charge: Enable or Disable based on need

Discharge:
Forced Discharge Enable: Disable
PV Sell To Grid (Comp. w/ NEM3.0): Enable

GridBOSS Settings:
 No changes required

Off-Grid Mode

In this example, the inverter's "Off-Grid Mode" is enabled. The inverter(s) will power the backup and smart loads. The grid will not provide supplemental power to the backup or smart loads but can charge the battery if AC charging is enabled. When AC charging is in use, the main grid relay will close. The non-backup loads can only be powered by the grid.

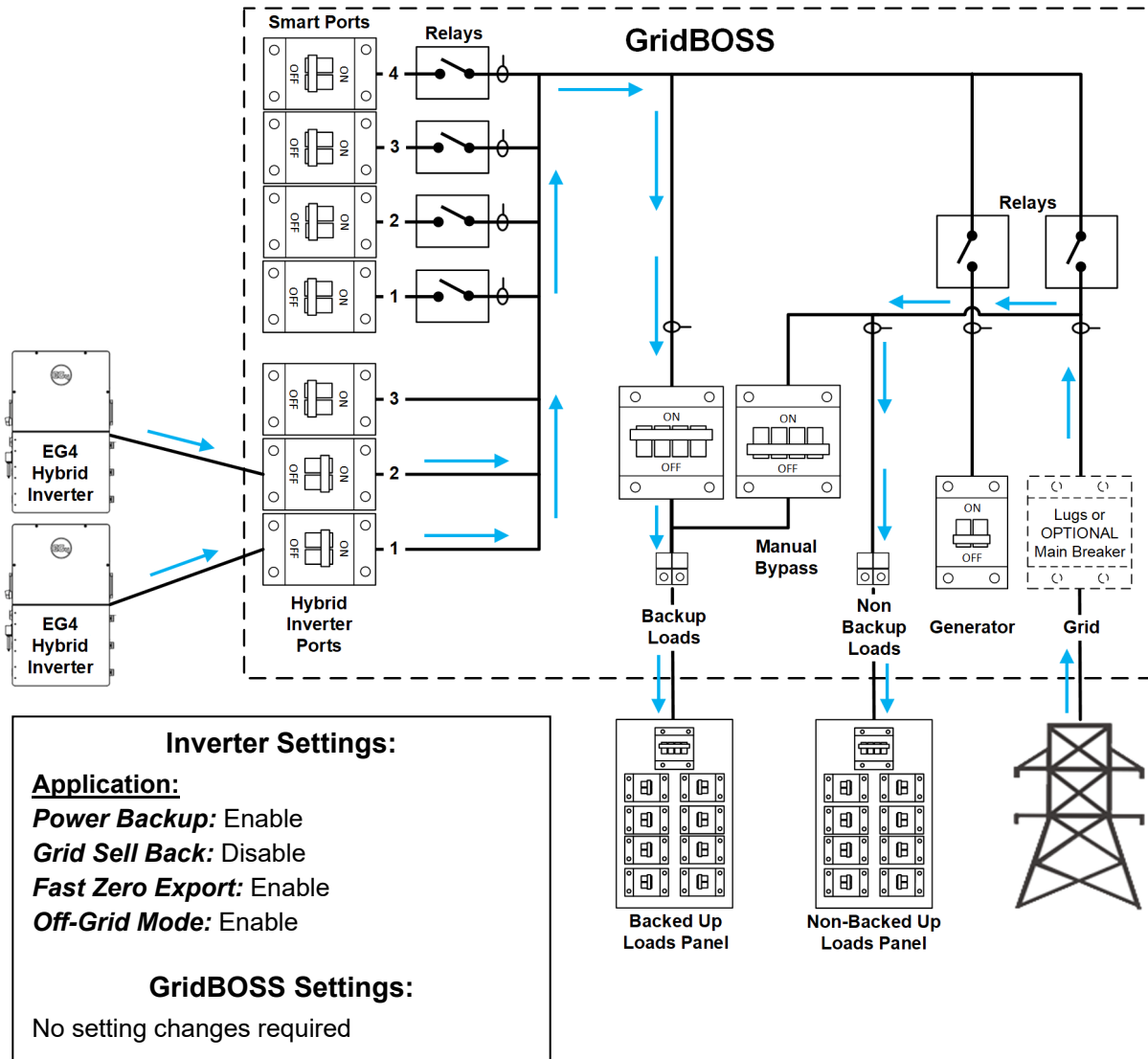

7.2 GENERATOR

In this example, a generator has been added to the GridBOSS to power the backup loads and supplement battery charging, if needed. The generator breaker and relay are closed, allowing current to flow to the backup loads. Generator output can assist in charging the batteries, provided the proper settings are configured and the loads are small enough, allowing the generator's extra power to charge the batteries. If a small generator is used that cannot fully power the critical loads, enable "Generator Boost" at the inverter. Verify that the generator start/stop wiring is properly connected to ensure that the generator start and stop functionality is supported. The smart ports in the example below will not receive current unless the ports are configured for operation in the EG4® Monitor Center.

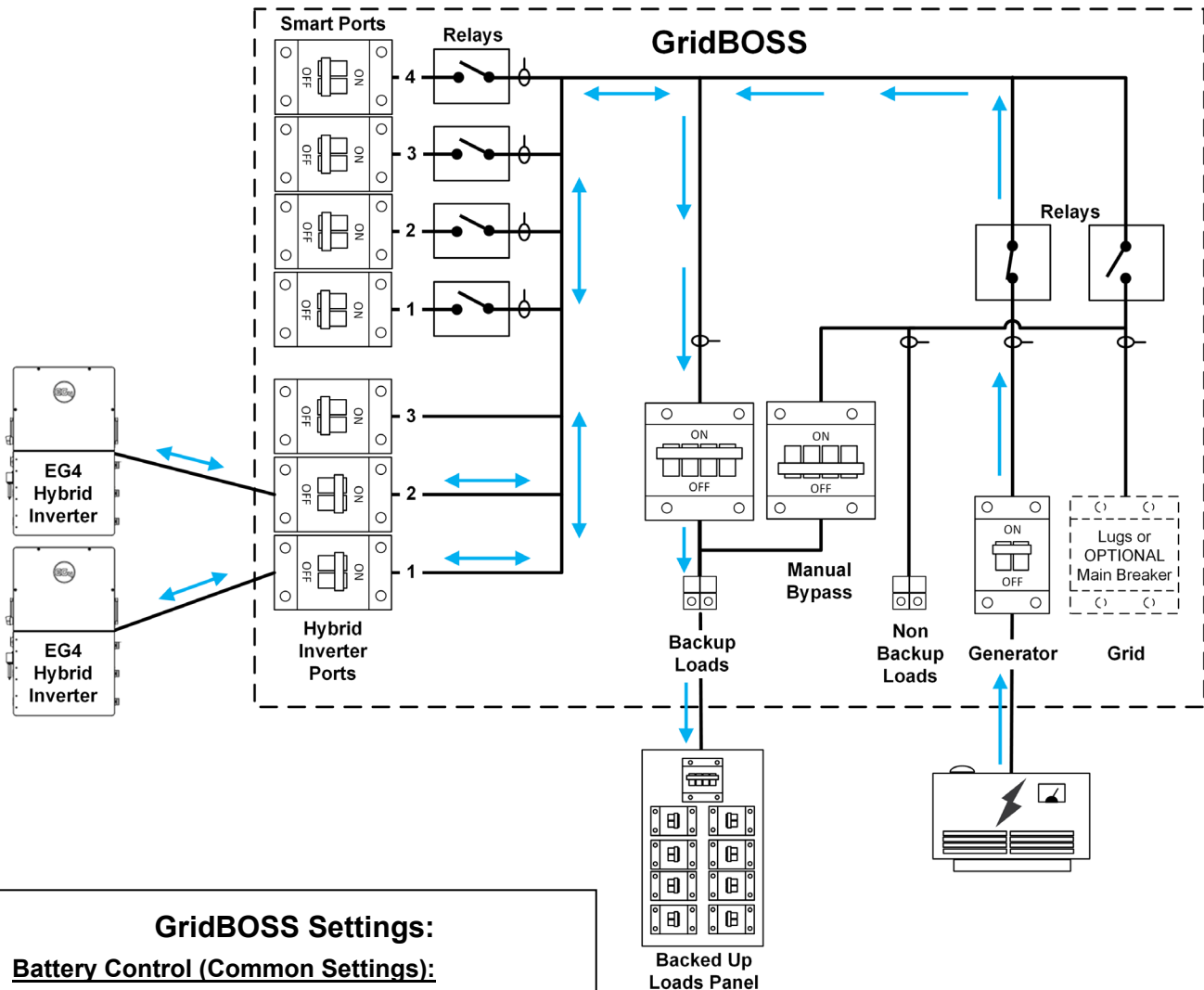

GridBOSS Settings:

Battery Control (Common Settings):

Charge Control: SOC

Discharge Control: SOC

GENERATOR:

Generator SOC/Vbat Enable: Enable

Batt Charge Current Limit (A_{dc}): 250

Gen Rated Power (kW): 25.5

Charge Start SOC: 50%

Charge End SOC: 80%

Generator Warm Up Time(s): 120

Generator Remote Auto Turn off time(m): 20

Inverter Settings:

Application:

Grid Sell Back: Enable or Disable

Fast Zero Export: Disable or Disable

Off-Grid Mode: Disable or Disable

Charge:

AC Charge: Enable or Disable

Generator Charge:

Generator Boost: Enable or Disable

7.3 MANUAL BYPASS MODE

In this scenario, all relays in the GridBOSS are bypassed, allowing grid current to flow directly to the backup loads port and power the critical loads panel. The bypass mode was set up to support critical loads in the unforeseen circumstance that GridBOSS needs to be bypassed. The non-backup loads port also receives power from the grid when the system is in manual bypass mode.

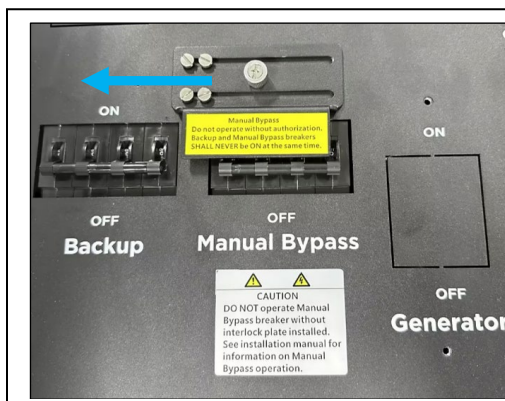
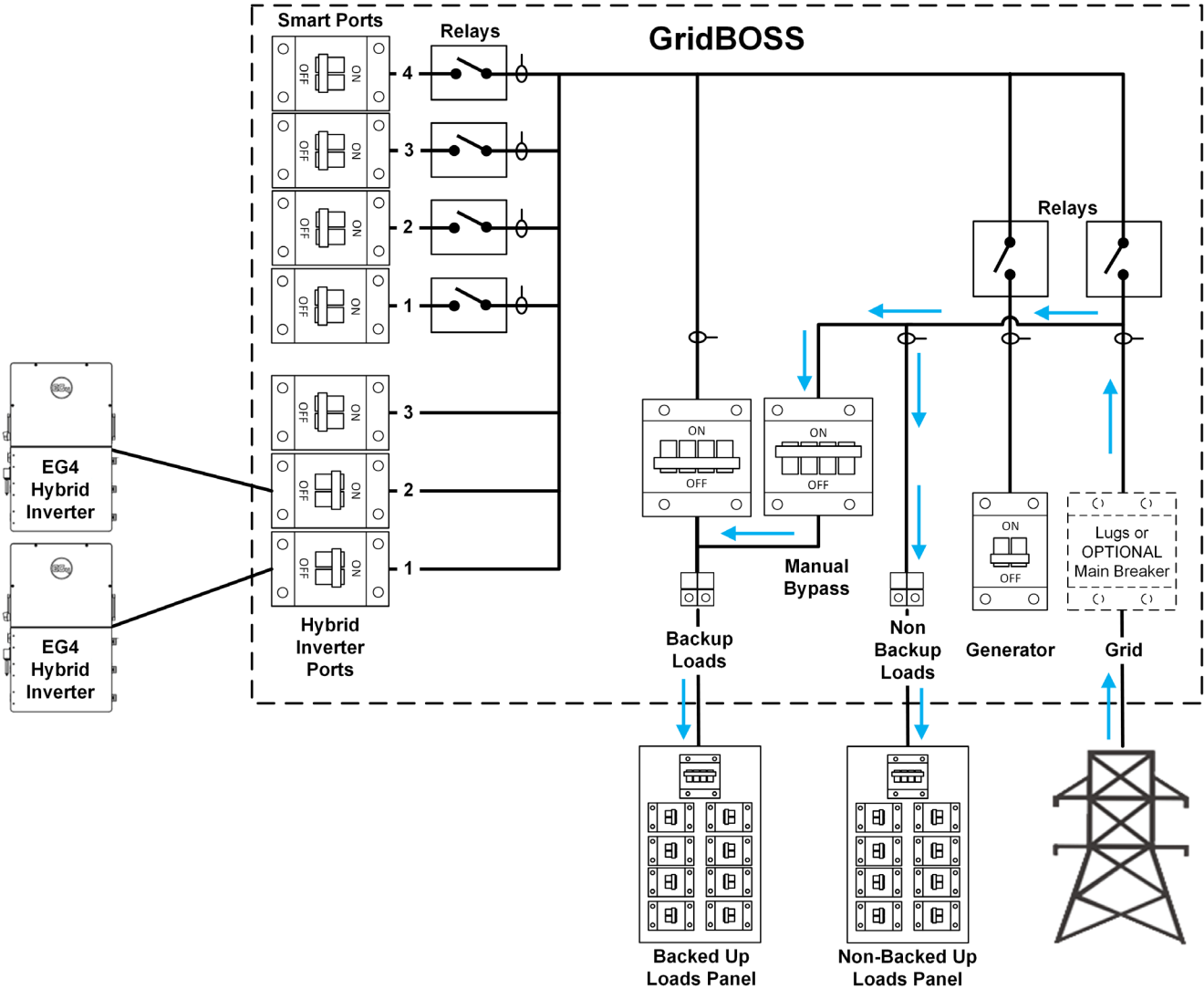

To enable manual bypass:

1. Set the "Backup" load breaker to the off position.
2. Slide the manual bypass interlock all the way to the left.
3. Set the "Manual Bypass" breaker to the on position.

7.4 SMART LOADS

In this scenario, a water heater and an electric vehicle charger are connected to smart ports 2 and 3. There are multiple ways a smart port can be configured using the EG4® Monitor Center, and this section will cover a few of these methods. The first option is to manually set the port to always be on or always be off. The second option is to turn the port on or off based on battery SOC and/or time periods. Another option is to use load shedding, which provides an additional setting for the PV input level.



NOTE:

Smart port functionality is not supported at the hybrid inverter when attached to a GridBOSS. All devices powered by a smart port must be connected directly to a GridBOSS smart port.

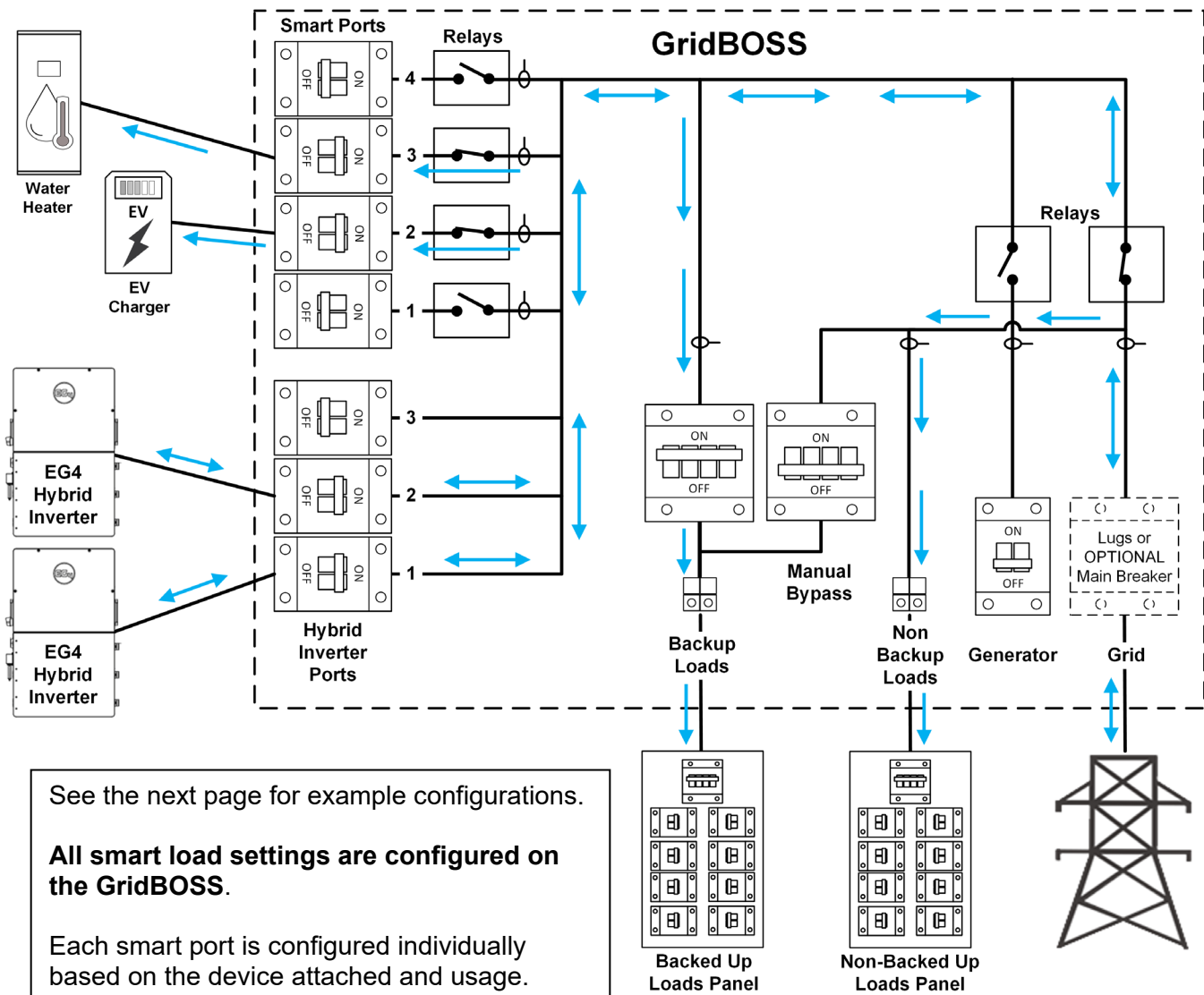

Example Configurations:

1. Always Powered On:

There are two options to enable a smart port to always be enabled. The first option enables the smart port when GridBOSS detects an active grid connection, utilizing the “Grid Always On” feature. If the grid goes down, the smart port relay will open, and the smart port will stop supplying power to the attached load. Verify that the inverter is not configured in Off-Grid mode to ensure that the smart port is enabled when the grid is present.

Battery Control (Common Settings):

Charge Control: SOC

Discharge Control: SOC

Grid Boss Smart Port #:

Smart Port Mode: Smart Load

Smart Load Enable: Enable

Smart Load Grid Always On: Enable

The second option utilizes time to enable the smart port for a 24-hour period, eliminating the requirement for grid input. In off-grid configurations, maintaining a smart port's power requires a large battery bank and a photovoltaic (PV) array that can quickly recharge the battery bank. To prevent the smart port load from depleting the battery's capacity and potentially causing the inverter to power down, it is recommended that the smart port be powered off when the battery's SOC falls below a defined level, using the “Smart Load End SOC” setting. In the example below, the smart port is enabled for a 24-hour period only when the battery's SOC is above 40%.

Battery Control (Common Settings):

Charge Control: SOC

Discharge Control: SOC

Grid Boss Smart Port #:

Smart Port Mode: Smart Load

Smart Load Based On: Time + SOC

Smart Load Enable: Enable

Smart Load Grid Always On: Disable

Smart Load Start Time: 00:00

Smart Load End Time: 23:59

Smart Load End SOC(%): 40%

2. Time + SOC or SOC: A smart port can be enabled by selecting a time period, SOC, or both. The left example on the next page enables the smart port between 10:00 a.m. and 6:00 p.m., and when the SOC is above 30%. The example on the right enables the smart port when the battery's SOC is above 70% and disables it when the battery's SOC falls below 30%.

Battery Control (Common Settings):

Charge Control: SOC

Discharge Control: SOC

Grid Boss Smart Port #:

Smart Port Mode: Smart Load

Smart Load Based On: Time + SOC

Smart Load Enable: Enable

Smart Load Grid Always On: Disable

Smart Load Start Time: 10:00

Smart Load End Time: 18:00

Smart Load End SOC(%): 30%

Battery Control (Common Settings):

Charge Control: SOC

Discharge Control: SOC

Grid Boss Smart Port #:

Smart Port Mode: Smart Load

Smart Load Based On: SOC/Volt

Smart Load Enable: Enable

Smart Load Grid Always On: Disable

Smart Load Start & End SOC(%): 70% and 30%

PV + SOC: This example uses PV as a factor in determining when the smart port is enabled or disabled. The smart load will be enabled when the PV is at least 1600W and the battery SOC is above 70%. The smart load is disabled when the PV is lower than 1600W or the SOC is lower than 30%.

Battery Control (Common Settings):

Charge Control: SOC

Discharge Control: SOC

Grid Boss Smart Port #:

Smart Port Mode: Smart Load

Smart Load Based On: SOC/Volt

Smart Load Enable: Enable

Smart Load Use Shedding Mode: Enable

Smart Load Power Shedding Start PV Power(W): 1600

Smart Load Power Shedding Start & End SOC(%): 70% and 30%

7.5 AC COUPLING

In this scenario, the existing AC-coupled PV is added to smart port 1. Smart port 1 is used for this example, but any smart port can be configured for AC coupling. The extra power provided by AC-coupled PV can be utilized by various loads in the system. Refer to the example configurations on the following page for additional details.

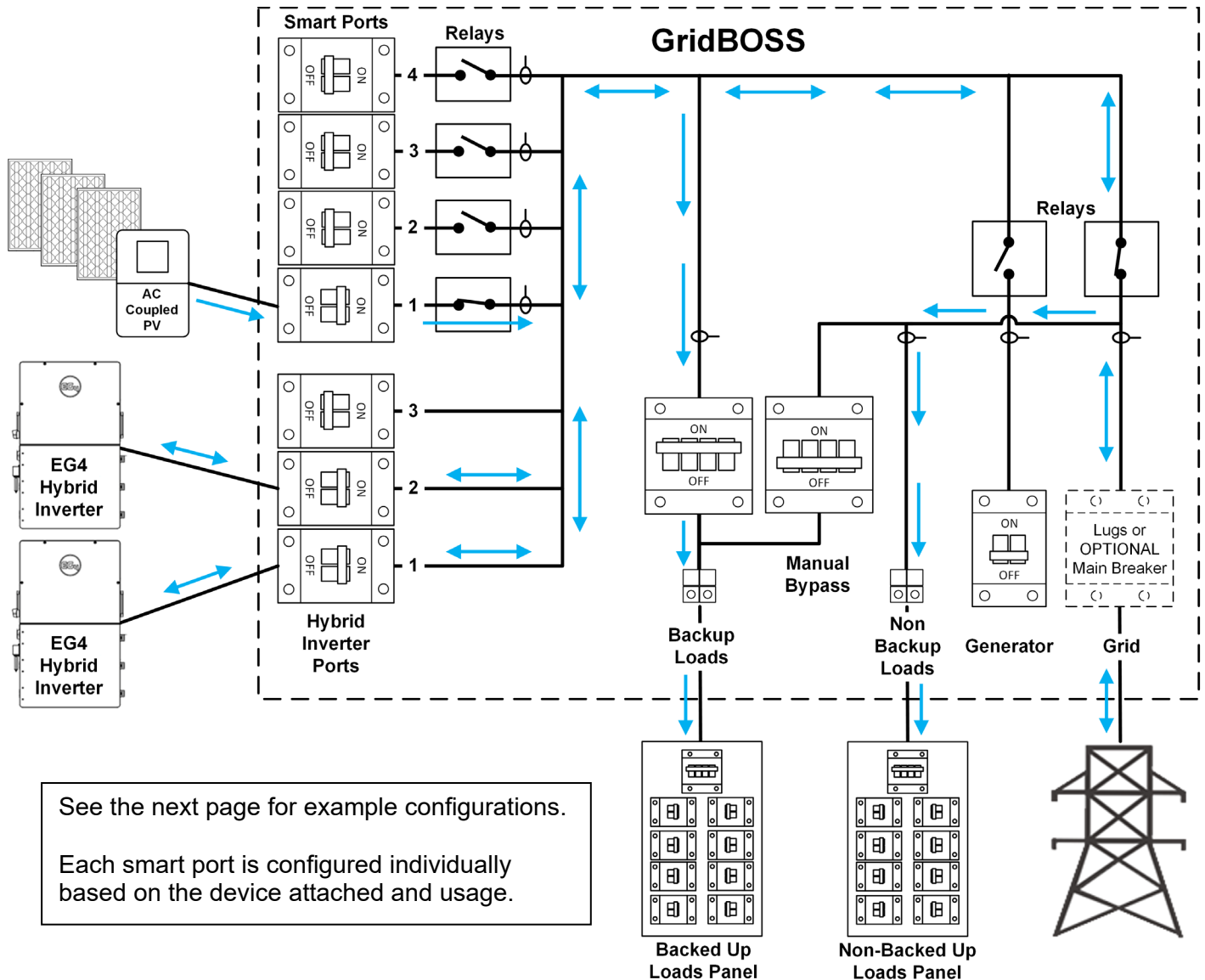

WARNING:

Verify that the AC-coupled device is certified to UL1741, UL1741SA, or UL1741SB standards. Uncertified devices may cause damage to the equipment's hardware.



NOTE:

Smart port functionality is not supported at the inverter generator port when attached to a GridBOSS. All AC-coupled devices must be connected directly to a GridBOSS smart port.

Example Configurations:

Grid Sell Back: In this example, the inverter is configured for grid sell-back. AC coupling will be utilized as supplemental power for the backup port, smart loads, and the non-backup port, as well as to assist with charging the batteries. Once the batteries are fully charged, AC-coupled power will continue to support load operations. This configuration will function only when the grid input is present.

GridBOSS Settings:

Battery Control (Common Settings):

Charge Control: SOC

Discharge Control: SOC

Grid Boss Smart Port #:

Smart Port Mode: AC Couple

AC Couple Enable: Enable

AC Couple Start & End SOC%: 30% & 100%

AC Couple Start Time: 00:00

AC Couple End Time: 23:59

Inverter Settings:

Application:

Power Backup: Enable

Grid Sell Back: Enable

Fast Zero Export: Disable

Off-Grid Mode: Disable

Charge:

AC Charge: Enable

Off-Grid Mode: In this example, the AC coupling configuration is only applicable when no grid power is present. If the grid is present, the AC-coupled inverter will not output power. The inverter is configured for off-grid mode, and AC coupling will be used as supplemental power to the backup port and the smart loads, as well as to assist with charging the batteries. Once the batteries are fully charged, AC-coupled power will continue to support the operation of loads. In this configuration, the non-backup port cannot be powered, as the grid input is inactive, preventing AC coupling in off-grid mode.

GridBOSS Settings:

Battery Control (Common Settings):

Charge Control: SOC

Discharge Control: SOC

Grid Boss Smart Port #:

Smart Port Mode: AC Couple

AC Couple Enable: Enable

AC Couple Start & End SOC%: 30% & 100%

AC Couple Start Time: 00:00

AC Couple End Time: 23:59

Inverter Settings:

Application:

Power Backup: Enable

Grid Sell Back: Disable

Fast Zero Export: Enable

Off-Grid Mode: Enable

Charge:

AC Charge: Enable

8. REMOTE SYSTEM MANAGEMENT

GridBOSS is remotely configured and monitored using the EG4® Monitor Center or mobile app. To enable remote connectivity, install the included dongle into the communication port on the upper right side of the unit. Use the four included screws to secure the dongle to the port.

Once the dongle is physically installed on the chassis, its serial number and PIN need to be added to an EG4 user account to set up remote connectivity. The serial number and PIN are found on a sticker located on the side of the dongle.

New EG4 users must create a new account. Existing users can also add GridBOSS to an existing account, as shown in section 8.2.



8.1 CREATE NEW ACCOUNT

Using EG4® Monitor Center

1. Using a web browser, connect to “monitor.eg4electronics.com” and select “Register”.

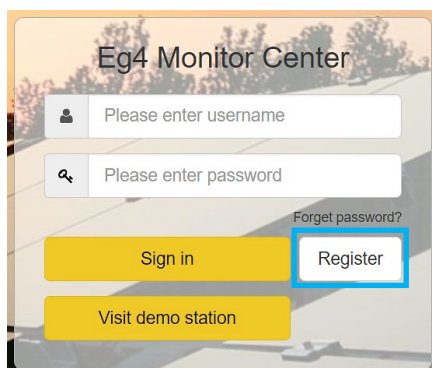

2. Complete the registration form as shown below. Contact the distributor for the customer code. The dongle serial number (SN) and dongle PIN can be found on the sticker attached to the side of the dongle.

* Username	<input type="text" value="Username"/>
* Password	<input type="password" value="Password"/>
* Repeat password	<input type="password" value="Repeat password"/>
Nickname	<input type="text" value="Nickname"/>
* E-mail	<input type="text" value="E-mail"/>
Tel number	<input type="text" value="Tel number"/>
<hr/>	
* Station name	<input type="text" value="Station name"/>
* Daylight saving time	<input type="radio"/> Yes <input checked="" type="radio"/> No
<hr/>	
* Continent	<input type="text" value="North America"/>
* Region	<input type="text" value="North America"/>
* Country	<input type="text" value="United States of America"/>
* Timezone	<input type="text" value="—"/>
Address	<input type="text" value="Address"/>
<hr/>	
* Customer code	<input type="text" value="Customer code"/>
<hr/>	
* Dongle SN	<input type="text" value="Dongle SN"/>
* Dongle PIN	<input type="text" value="Dongle PIN"/>
<hr/>	
<input type="button" value="Register"/> <input type="button" value="Back to login page"/>	

3. Once the registration is complete, return to the EG4® Monitor Center web page and log in using the username and password created during the registration process.

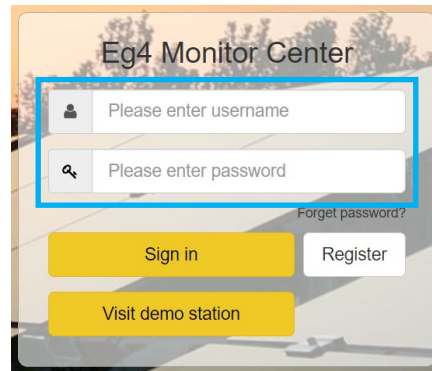

Using the Mobile App

1. Download the “EG4® Monitor” app for iOS or Android. After installation is complete, open the app.
2. Select “Register,” then complete the required information and select “Register.” Contact the distributor for the installer code.

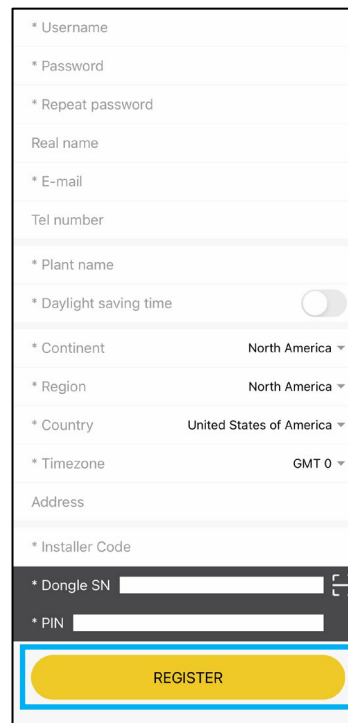
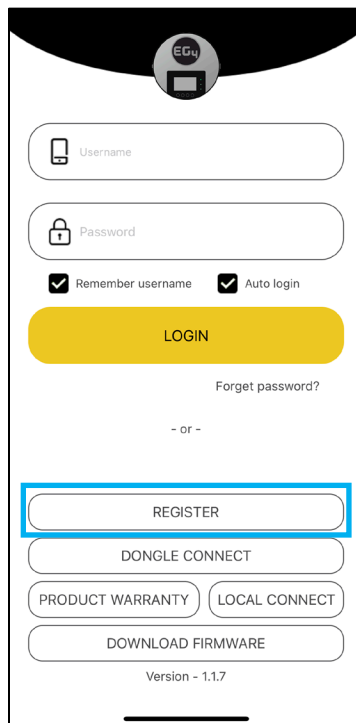

3. Once the registration is complete, return to the login page and log in using the username and password created during the registration process.

8.2 EXISTING ACCOUNTS

When an EG4® account already exists, newly added EG4 hardware that uses a dongle can be added to it. This can be completed using the EG4 Monitor Center or the mobile app.

Using EG4® Monitor Center

1. Using a web browser, open “monitor.eg4electronics.com” and log in with the existing username and password.

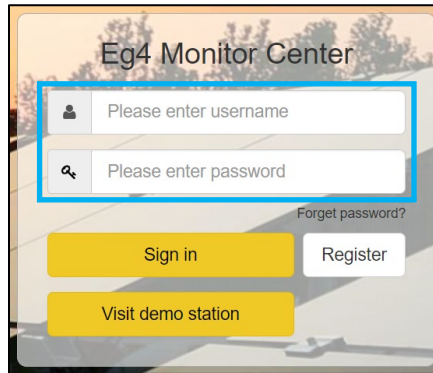

2. Select the “Configuration” tab, then select “Dongles.”
3. Select “Add Dongle”.
4. Enter the new dongle serial number and pin, select the station to assign the dongle, and then select “Add”.
5. GridBOSS should now be available in the Monitor Center.

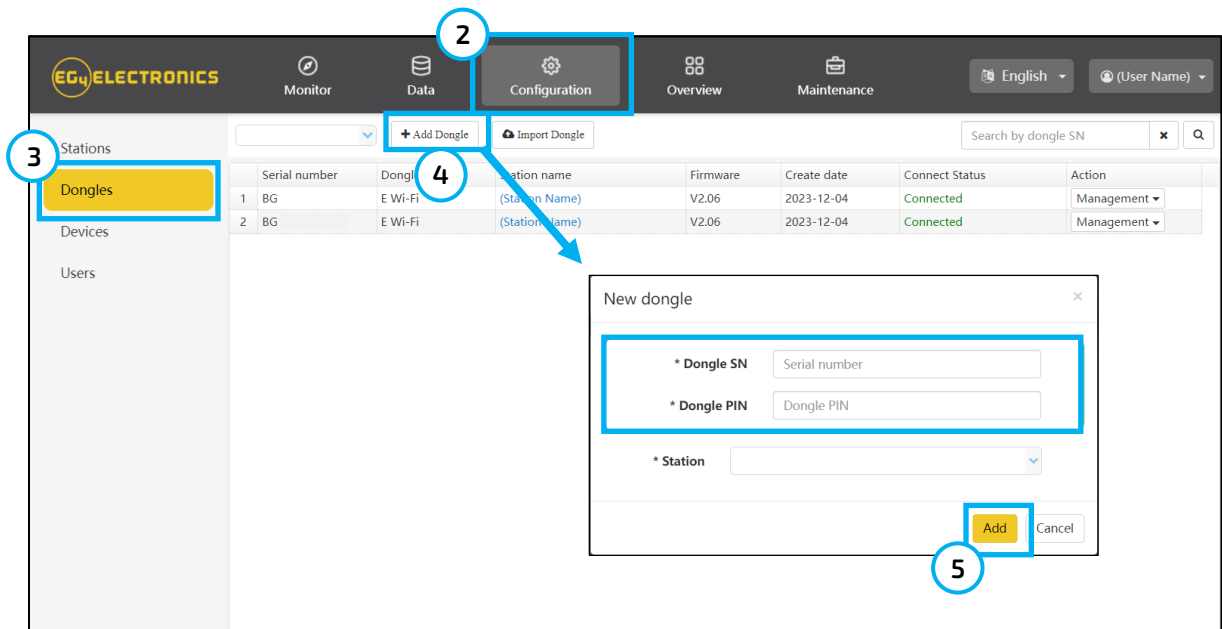

Using the Mobile App

1. Open the “EG4 Monitor” app and log in using an existing name and password.
2. Select the back arrow in the upper left corner of the screen.
3. Select “Add Dongle”.
4. Scan or enter the dongle information located on the dongle sticker, then select “Add Dongle”.

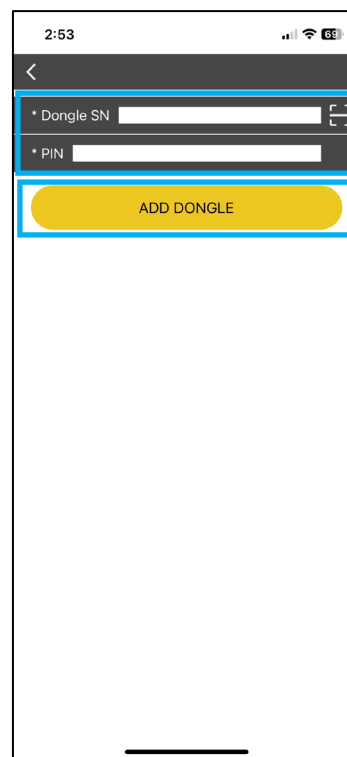
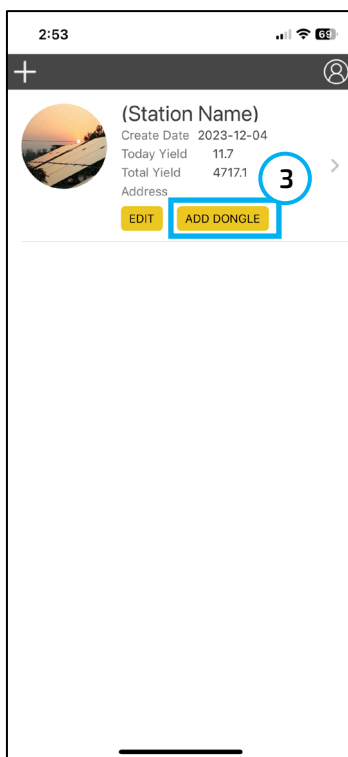
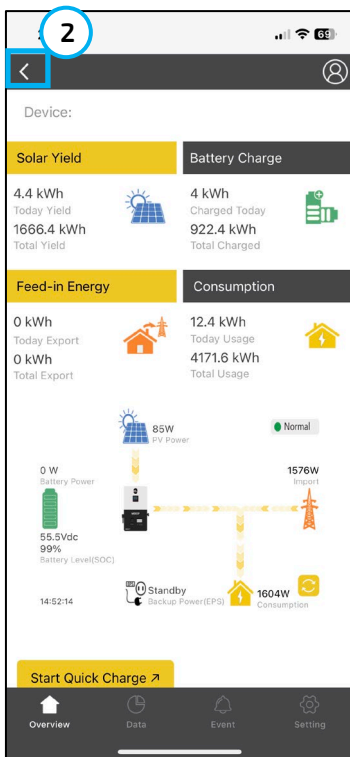

9. EG4 MONITOR CENTER

New areas are added to the EG4® Monitor Center main page when viewing GridBOSS. All AC input and output information shows what is directly connected to the GridBOSS ports. All DC input and output information is pulled from the hybrid inverter.

- A. **Smart Ports:** Smart port information by port (numbered left to right)
- B. **Generator:** Generator information
- C. **Solar:** The total amount of incoming solar from all attached hybrid inverters
- D. **Inverter:** Attached hybrid inverter(s)
- E. **Grid:** Grid watts, AC voltage, and frequency attached to the GridBOSS grid port
- F. **Battery:** Total battery SOC, voltage, and watts
- G. **Load Ports:** Backup load and non-backup load output data

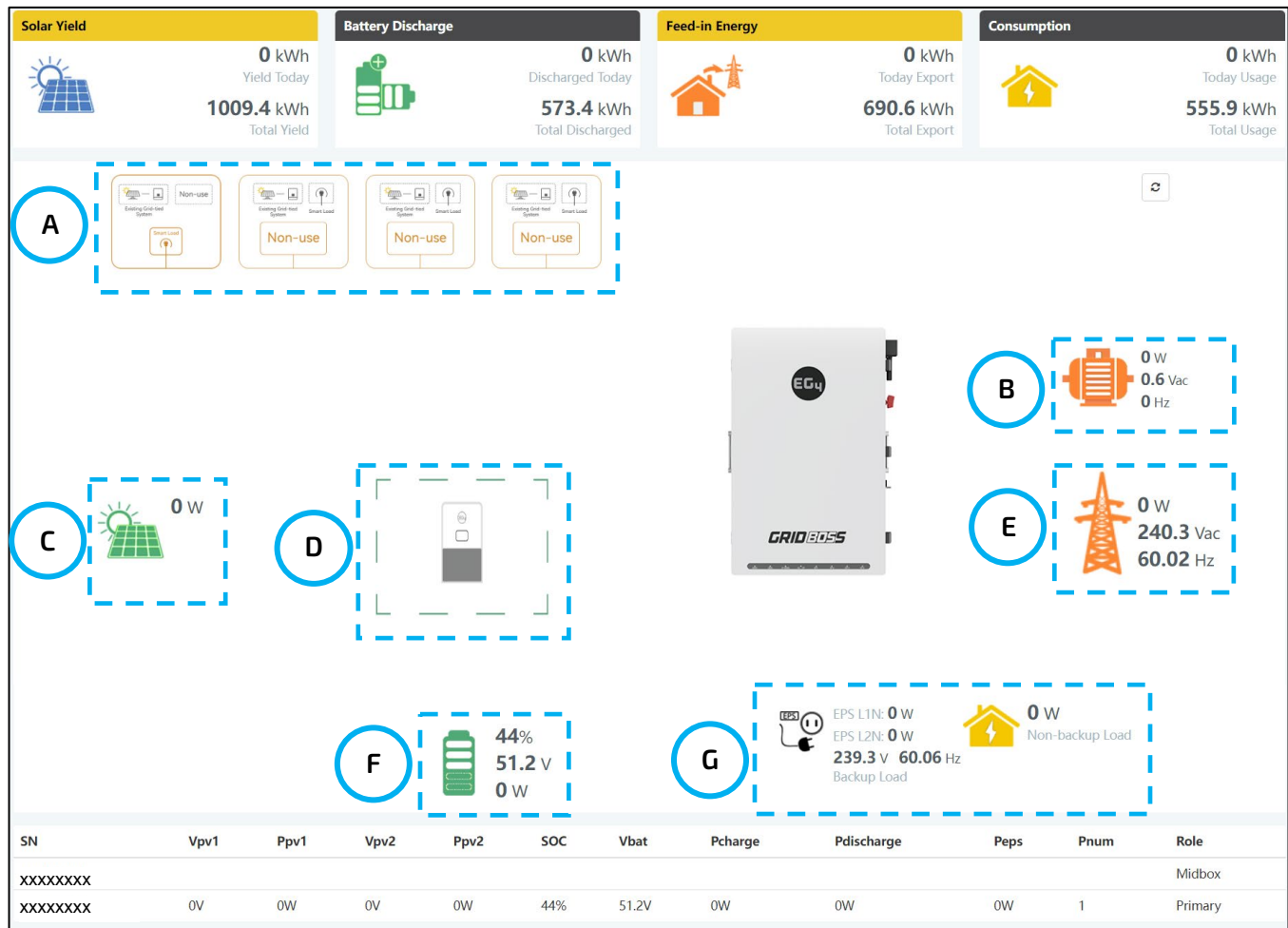

9.1 MAINTENANCE TAB

This section describes the settings for each area within GridBOSS. As a best practice, always start by selecting the “Read” button at the top of the maintenance page. This will refresh the settings page, displaying the values currently set for each option.

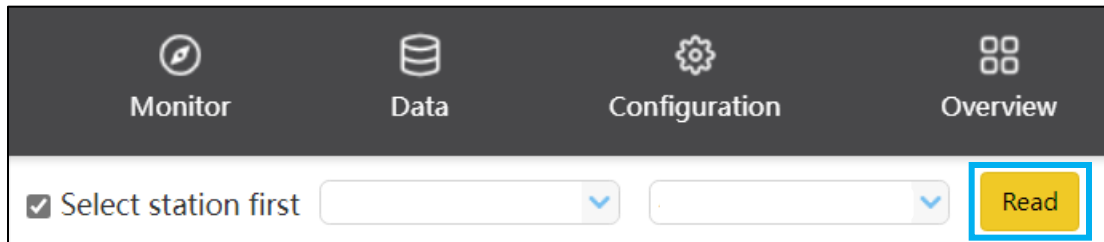

COMMON SETTING

Configure the time and charge/discharge control based on voltage or State of Charge (SOC). It is recommended to use SOC when using closed-loop communications with LFP batteries. Use voltage when using lead-acid batteries or LFP batteries with the lead-acid setting.



GRIDBOSS SMART PORTS 1–4

There are a total of four smart ports (1-4) that can be configured as “Unused,” “Smart Load,” or “AC Couple.” The default is “Unused”. Before changing the port setting, press the “Read” button at the top of the page to display the currently configured settings. After reading the data, the Smart Port Mode will be changed from “<Empty>” to its current setting.

Select the desired working mode from the drop-down menu. Press the “Set” button to save the change. The smart port will display the proper setting parameters for the selected port mode.

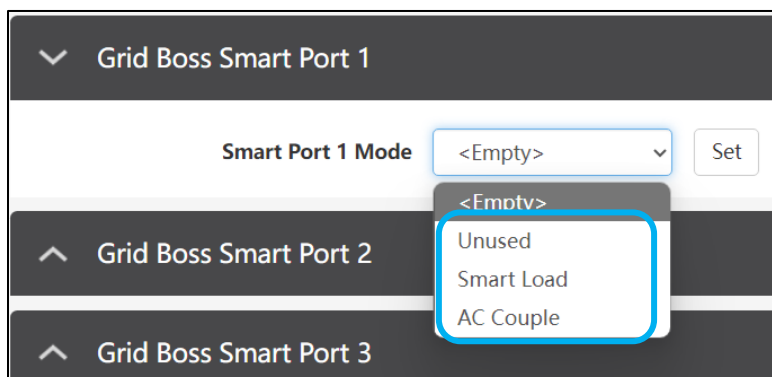

SMART LOADS

This section describes the various smart load settings. There are three areas within the smart port settings page. The first area is used for load shedding and uses SOC/voltage to enable and disable the load port (outlined in blue). The goal is to turn off a smart load when the battery's state of charge (SOC) reaches a low threshold. The second area is used to configure power shedding, which adds PV power as an option for enabling the load port (outlined in green). The goal is to enable a smart port when unused PV is available to power a load. The last area is used to enable or disable a smart load based on time or to add a time period to SOC/Voltage.

The screenshot shows the 'Grid Boss Smart Port 1' settings interface. At the top, 'Smart Port 1 Mode' is set to 'Smart Load'. Below this, there are three main configuration areas:

- Smart Load based on 1 (Blue border):** Includes a dropdown menu set to '<Empty>' and 'Set' buttons. It has 'Smart Load 1 Enable' and 'Smart Load 1 Grid Always On (?)' options, each with 'Enable' and 'Disable' buttons. On the right, there are four input fields for 'Smart Load 1 Start SOC(%)', 'Smart Load 1 End SOC(%)', 'Smart Load 1 Start Volt(V)', and 'Smart Load 1 End Volt(V)', each with a 'Set' button.
- Power Shedding Mode 1 (Green border):** Includes 'Power Shedding Mode 1' with 'Enable' and 'Disable' buttons. Below it is 'Smart Load 1 Power Shedding Start PV Power(kW)' with a range input '[0, 25.5]' and a 'Set' button. On the right, there are four input fields for 'Smart Load 1 Power Shedding Start SOC(%)', 'Smart Load 1 Power Shedding End SOC(%)', 'Smart Load 1 Power Shedding Start Volt(V)', and 'Smart Load 1 Power Shedding End Volt(V)', each with a 'Set' button and a progress indicator.
- Time-based settings (Grey border):** A table with columns for 'Start' and 'End' times, each with a range input and a 'Set' button. There are three rows labeled T1, T2, and T3.

Smart Port Mode: Unused | Smart Load | AC Couple

Select "Smart Load" to configure the smart port with smart load settings.

Smart load based on: Empty | Time | SOC/Volt | Time + SOC/Volt

Select "Time" to configure the smart load based on a time period. Select "SOC/Volt" to configure the smart load based on battery SOC% or voltage level.

Smart Load Enable: Enable | Disable

Turns the smart load feature on or off. Always select disable until the port is fully configured and ready to be turned on.

Smart Load Grid Always On: Enable | Disable

Enable: The port relay will remain in the closed (on) position when there is grid input.

Disable: The port relay will operate based on time and/or SOC/Volt settings, regardless of the grid connection's state.

Load Shedding:

The smart load is configured using time periods and/or SOC/voltage. The port will be active if within the set time period and/or when the SOC or voltage is above the specified start value. The port will be disabled if outside the specified time period, and/or the end SOC/voltage is below the set value.

Smart Load Start & End SOC(%): [0, 100] and [0, 100]

The smart load port is enabled when above the starting SOC and disabled when below the SOC. Values are 0 – 100%.

Smart Load Start Volt: [40V – 59V]

The smart load port is enabled when above the defined voltage value.

Smart Load End Volt: [40V – 59V]

The smart load port is disabled when below the defined voltage value.

Smart Load Start Time: [00:00 – 23:59]

The smart load port is enabled at the defined start time. If one of the three time periods is met, the port relay will close (power on). Range is 00:00 – 23:59

Smart Load End Time: [00:00 – 23:59]

The smart load port is disabled according to the defined end time. Range is 00:00 – 23:59

Power Shedding:

PV power is also used in the configuration when using the power shedding mode. If the “Grid Always On” is disabled and the PV power is above the set value, the port will be enabled. If a time period and/or battery SOC/voltage is added to the start PV setting, all defined settings must be met for the port to be active. The port will be disabled when configured settings are outside the defined enabled values. If ‘Grid Always On’ is enabled, and there is a grid connection, the port will remain active regardless of PV input, time, or battery SOC/voltage.

Smart Load Use Shedding Mode: Enable | Disable

Enable: Allows the port to use PV wattage to enable or disable power to the port.

Disable: Do not use PV wattage to enable or disable power to the port.

Smart Load Power Shedding Start PV Power (kW): 0 – 25.2kW

This is the low PV input threshold. When the PV input wattage goes below the set value, the port is disabled.

Smart Load Power Shedding Start & End SOC: [0, 100] and [0, 100]

The smart load port is enabled above the starting SOC and disabled when below the SOC. Values are 0 – 100%.

Smart Load Power Shedding Start Volt (V): [40V – 59V]

The smart load port is enabled when above the defined voltage value.

Smart Load Power Shedding End Volt (V): [40V – 59V]

The smart load port is disabled when below the defined voltage value.

Smart Load Start Time: [00:00 – 23:59]

The smart load port is enabled at the defined start time. If one of the three time periods is met, the port relay will close (power on). Range is 00:00 – 23:59

Smart Load End Time: [00:00 – 23:59]

The smart load port is disabled according to the defined end time. Range is 00:00 – 23:59

AC COUPLE

This section describes the various AC coupling settings. When configuring AC coupling, the enablement and start/stop settings are configured within the GridBOSS settings area of the EG4® Monitor Center. There are inverter settings that also interoperate with the functionality of the GridBOSS AC coupled port.

When the inverter is operating in on-grid mode, the GridBOSS will disregard the battery's SOC and voltage. The AC-coupled relay will be closed (powered on) when the hybrid inverter's "Export to Grid" setting is enabled and the time period logic is met. The GridBOSS will also open (power off) the AC-coupled port relay when the hybrid inverter's "Export to Grid" function is disabled, thereby preventing power from being pushed to the grid.

When the inverter is operating in off-grid mode, the GridBOSS controls the AC couple relay based on the battery state of charge (SOC), voltage, and/or time period logic. The relay will also be opened (powered off) if the inverters receive too much power from the AC coupled inverter.

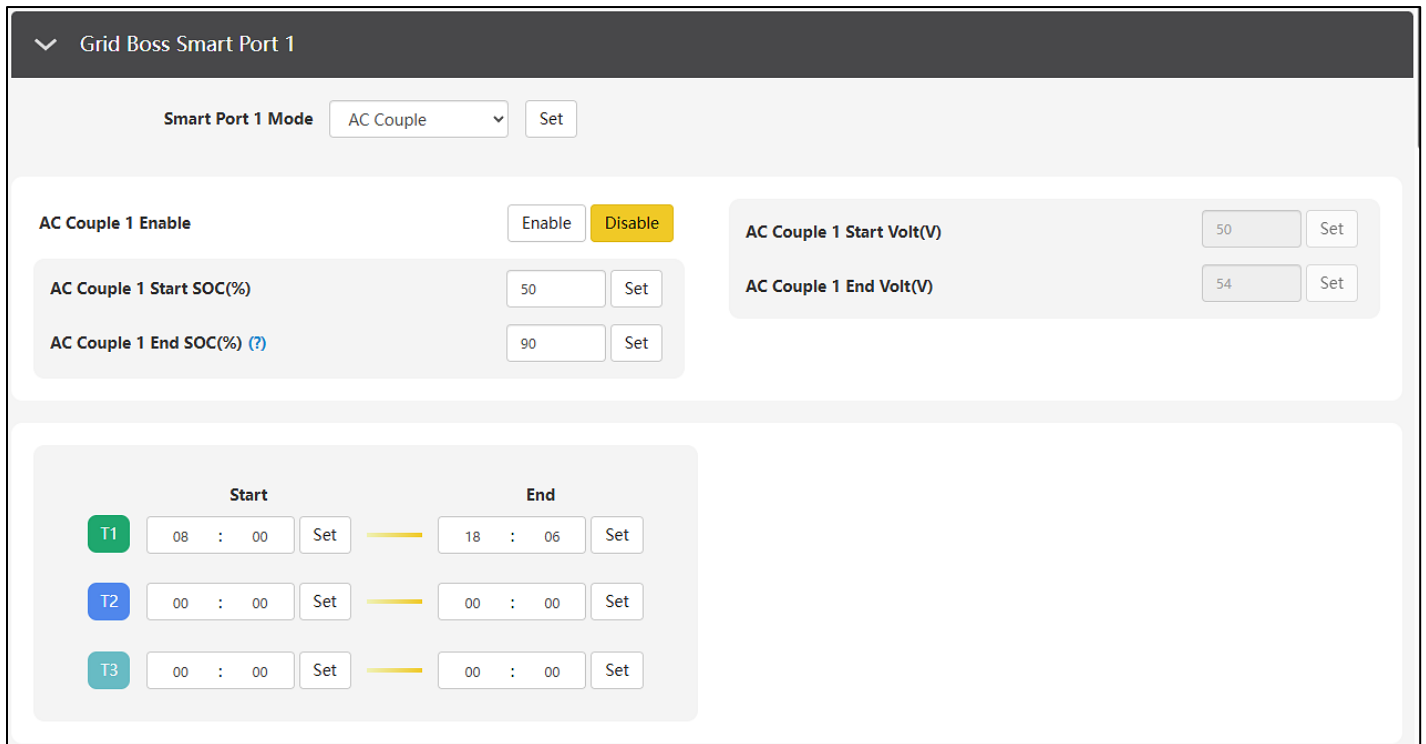

Smart Port Mode: Unused | Smart Load | AC Couple

Select AC Couple to enable the smart port to be configured with AC Couple settings.

AC Couple Enable: Enable | Disable

Turns the AC couple feature on or off. Always select "Disable" until the port is fully configured and ready to be turned on.

AC Couple Start & End SOC(%): [0 – 100] and [0 – 100]

The SOC values that enable and disable the AC coupled port

AC Couple Start Volt: [40V – 59V]

The AC couple port is enabled when below the configured voltage value.

AC Couple End Volt: [40V – 59V]

The AC couple port is disabled when above the configured voltage value.

AC Couple Start Time: [00:00 – 23:59]

The AC couple port is enabled at the defined start time. If one of the three time periods is met the port relay will close (power on). Range is 00:00 – 23:59

AC Couple End Time: [00:00 – 23:59]

The AC couple port is disabled at the defined end time. Range is 00:00 – 23:59

GENERATOR

All generator settings must be set on the GridBOSS using the EG4® Monitor Center or EG4 app. The inverter generator settings should not be used, except for the “GEN Boost” setting. When “GEN Boost” is disabled at the inverter, the inverter will operate using the GridBOSS generator settings. When “GEN Boost” is enabled at the inverter, the inverter operates according to the GridBOSS generator power minus 400W.

Generator SOC/Vbat Enable	<input type="button" value="Enable"/> <input type="button" value="Disable"/>	Generator Remote Turn On/Off	<input type="button" value="Enable"/> <input type="button" value="Disable"/>
Batt Charge Current Limit(Adc) (?)	<input type="text" value="[0, 250]"/> <input type="button" value="Set"/>	Gen Rated Power(kW) (?)	<input type="text" value="[0, 25.5]"/> <input type="button" value="Set"/>
Charge Start Volt(V)	<input type="text" value="[40, 57]"/> <input type="button" value="Set"/>	Charge Start SOC(%)	<input type="text" value="[0, 100]"/> <input type="button" value="Set"/>
Charge End Volt(V)	<input type="text" value="[42, 59]"/> <input type="button" value="Set"/>	Charge End SOC(%)	<input type="text" value="[0, 100]"/> <input type="button" value="Set"/>
Generator Warm Up Time(s)	<input type="text" value="[30, 600]"/> <input type="button" value="Set"/>	Generator Remote Auto Turn off time(m)	<input type="text" value="[5, 20]"/> <input type="button" value="Set"/>

Generator SOC/Vbat Enable: Enable | Disable

Enable or disable generator charging based on the State of Charge (SOC) or battery voltage. If disabled, the generator will not be controlled using SOC or battery voltage, and remote turn on/off must be used.

Generator Remote Turn On/Off: Enable | Disable

Manual control of dry contact 1. Set to enable to start the generator or set to disable to stop the generator.

Batt Charge Current Limit (Adc) [0 – 250]

Set the battery charging limit based on DC amperage.

Gen Rated Power (kW): [0 – 25.5]

Set the maximum generator input power.

Charge Start Volt: [40 – 59V]

The generator starts using dry contact 1 when the battery voltage is below the charge start voltage setting. Set according to the battery requirements.

Charge End Volt: [40 – 59V]

Stops the generator using dry contact 1 when the battery voltage exceeds the charge end voltage setting. Set this according to the battery requirements.

Charge Start SOC: [0 – 90%]

The generator starts using dry contact 1 when the battery SOC is below the charge start SOC setting. Set this according to the battery requirements.

Charge End SOC: [20 – 100%]

Stops the generator using dry contact 1 when battery SOC is above the charge end SOC setting. Set this according to the battery requirements.

Generator Warm Up Time(s): [30 – 600]

Sets the “Generator Warm Up Time” in seconds. The generator relay will close only after the warmup time is complete. GridBOSS will restart the warmup period if the generator’s voltage is detected as abnormal during the warm-up process.

Generator Remote Auto Turn off time(m): [5 – 20]

Sets the “Generator Remote Auto Turn Off Time” in minutes. GridBOSS will automatically power off the generator according to the Auto Turn-off Time. This setting can also be used for a generator exercise function.

10. FIRMWARE UPDATES

Before commissioning the system, please ensure the GridBOSS and inverter firmware are fully up to date. When upgrading the firmware, the GridBOSS and inverters utilize system firmware. The 12kPV and 18kPV inverters also utilize LCD firmware. The system firmware can be updated using the EG4® mobile app or the Monitor Center, described below.

10.1 SYSTEM - EG4 MOBILE APP



NOTE:

When updating the firmware through the EG4 app, ensure the device has plenty of battery life and do not close the app. Before proceeding with the following steps, ensure that the Wi-Fi dongle is securely connected and properly configured.

1. Open the mobile device's wireless settings. Locate and select the dongle's serial number as the Wi-Fi network. The dongle's network ID will be the same as the dongle's serial number.
2. Open the EG4 app and select "LOCAL CONNECT." The app should now be connected to the inverter or GridBOSS (whichever was selected in step 1).
3. With the app still running, return to the mobile device's Wi-Fi settings. Connect the home Wi-Fi network for internet access.
4. Switch back to the EG4 app on the mobile device. Select the correct device type from the drop-down menu. Then select the "DOWNLOAD" button. To view the firmware change log, select the "Changelog" button.
5. Once the check mark appears beside each firmware package, the download is complete. If the check marks do not appear, ensure Wi-Fi is connected to the home network and not the dongle serial number.
6. With the app still running, go back to the mobile device's Wi-Fi settings. Connect the mobile device back to the Wi-Fi dongle's network.
7. Switch back to the EG4 app and select the "CONNECT DEVICE AND UPDATE" button. Next select the "Update Firmware" button. The firmware update process should begin. Do not close the app or change wireless settings while the update is taking place.
8. Once the update is complete, the app will display "Update firmware successfully".

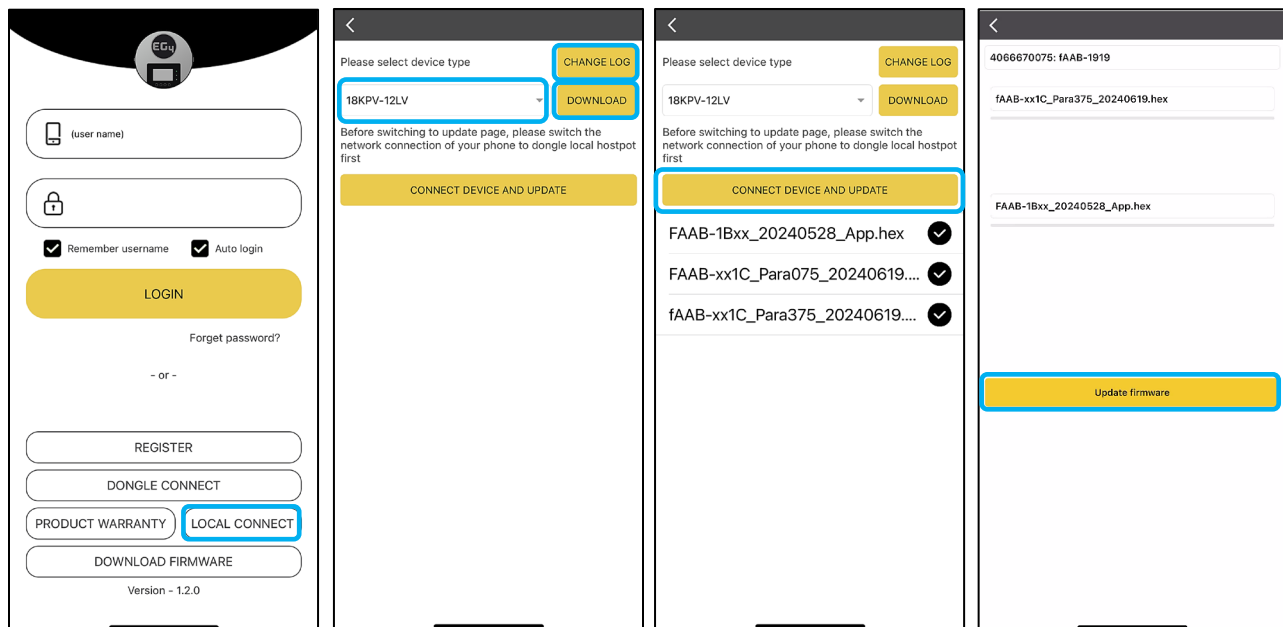
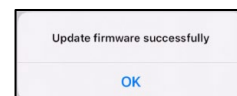

10.2 SYSTEM - EG4 MONITOR CENTER

1. Log in to the EG4® Monitor website. Select the “Maintenance” tab.
2. Select “Remote Update” on the left side of the screen.
3. Locate the unit needing the update by serial number. Select the blue question mark box next to the current firmware version.
4. Select “Check more” to view the release notes for the latest release. Close the release notes.
5. Check the “Upgrade Policy” check box, then select the “Standard Update” button to initiate the firmware update process. The Monitor Center will begin updating both firmware files for the inverter.

The screenshot displays the EG4 Monitor Center interface. At the top, the navigation bar includes 'Monitor', 'Data', 'Configuration', 'Overview', and 'Maintenance' (selected). Below the navigation bar, there are search filters for 'Station' and 'Online Device'. A table lists units with columns for 'Serial number', 'Dongle', 'Firmware version', 'Connect Status', and 'Action'. A yellow 'Remote Update' button is visible on the left. A 'Check Updates' modal is open, showing details for unit FAAB-1D1D, including 'Serial number', 'Firmware version', and 'Suggestion: No updates'. A 'Firmware Change log' modal is also open, showing a list of updates and a 'Check more' link. The 'Standard Update' button is highlighted in the bottom modal.

10.3 INVERTER LCD – USB DRIVE

Follow the steps listed below to update the inverter LCD firmware. A 2GB – 16GB USB flash drive is required. This update requires the inverter to be shut down and restarted.

Download the LCD firmware file using the QR code listed below. The firmware update will be listed under Inverters → 18kPV → Firmware.



EG4 LCD Firmware

LCD Update Steps:

1. Plug the USB flash drive into a Windows PC.
2. Format the flash drive using the following settings:
 - File system: FAT32
 - Allocation unit size: 4096 Bytes
 - Select “Quick Format”
3. Press “Start” to format the USB flash drive. **ALL** existing data on the flash drive will be **ERASED!**
4. Create a folder on the flash drive named **DWIN_SET**
5. Extract the downloaded zip file containing the LCD firmware to the DWIN_SET folder created on the flash drive.
6. Open the DWIN_SET folder on the flash drive and verify there are seven total files as follows:
 - .bin (4 files)
 - .icl (2 files)
 - .CFG (1 file)

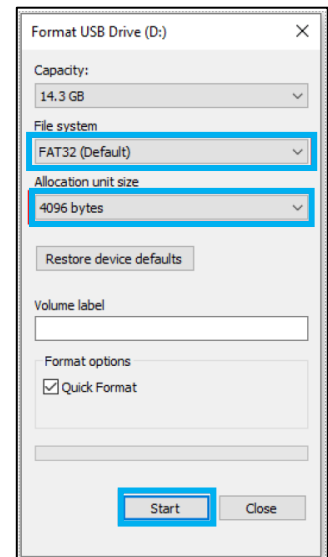

In file explorer, use the “Details” view and make sure “File name extension” is checked.

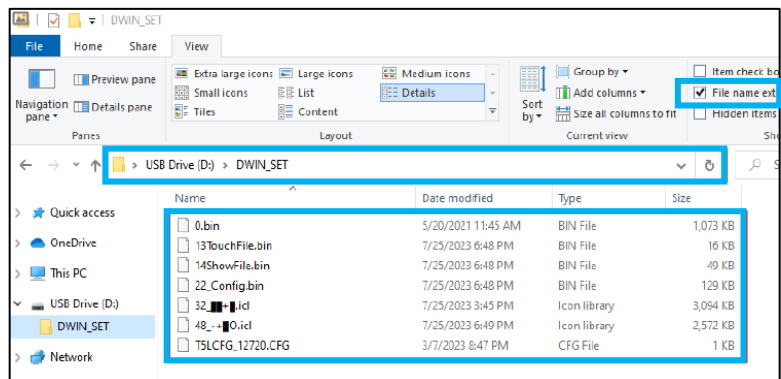

7. Safely remove the USB flash drive from the computer.
8. Power off the inverter.
9. Insert the USB flash drive into the USB port on the inverter's communications board, as shown in the image.
10. After the USB flash drive has been connected, power on the inverter. **DO NOT** power off the inverter during the update process.
11. The inverter will display a loading screen for 3 – 5 minutes.
12. After the LCD resets, navigate to:
Settings → Device info. → LCD version
to confirm that the LCD was correctly updated.

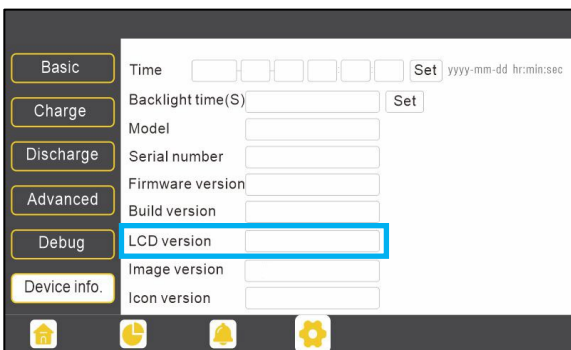
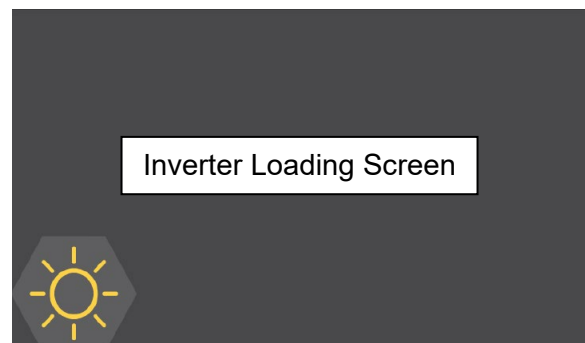
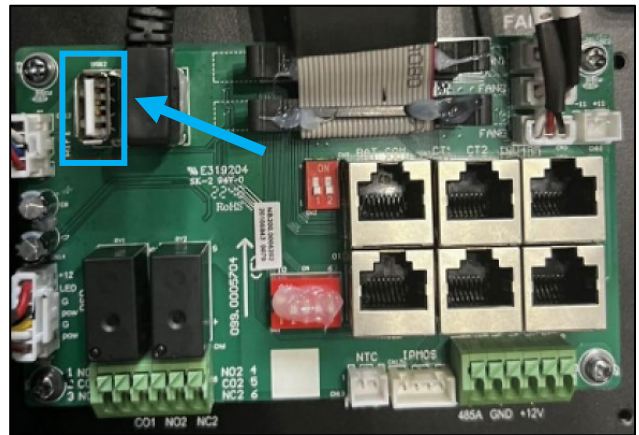

11. TROUBLESHOOTING

11.1 FRONT PANEL LEDS

The front panel LEDs represent the working status for each port or group of ports. An individual port operating normally will have a solid green LED. If there is a fault, the port with the fault will have a flashing green LED. When a firmware update occurs, all the port LEDs flash with a green LED.

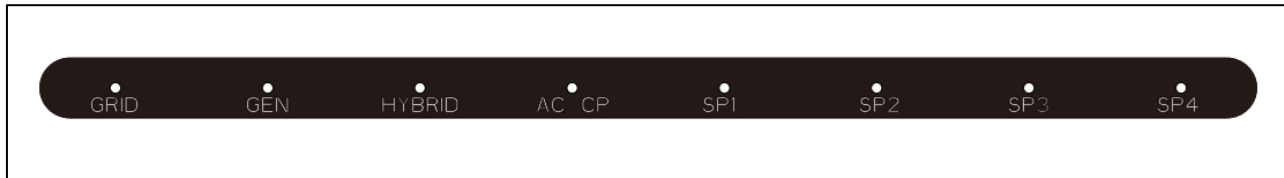

LED Fault Indicators:

PORT	LED	STATUS
GRID	Blink every 100 ms	Load overcurrent
GEN	Blink every 100 ms	Generator overcurrent
HYBRID	Blink every 100 ms	EPS load overcurrent Parallel RSD alarm is triggered The inverter is running old firmware The inverter stops outputting
	Blink every 500 ms	CAN communication cable is disconnected
AC CP	Blink every 100 ms	AC coupled port cannot be closed
SP1 – SP4	Blink every 100 ms	Smart port overcurrent Smart port 4 trigger NEC PCS protection

11.2 ERROR CODES

CODE	INFO	DESCRIPTION	RECOMMENDATION
E004	Inverter Firmware Mismatch	The inverter is running an older firmware that is not compatible with the GridBOSS.	Update the inverter FW to a version supported by the GridBOSS.
E005	NEC Protection	The current is more than 80% of the maximum current value supported by the busbar.	Verify that the total system load is less than 80% of the maximum busbar limit setting. Reduce system load to under 80%.
E006	Grid OCP	Grid port has overcurrent protection	Verify the grid port load does not exceed 220A for more than 1 minute.
E007	NBC Load OCP	Non-backup Load port has overcurrent protection	Verify the non-backup port load does not exceed 220A for more than 1 minute.
E008	GEN OCP	The generator port has overcurrent protection	Verify the generator port does not exceed 137.5A for more than 1 minute.
E009	BC Load OCP	Backup Load port has overcurrent protection	Verify the backup load port does not exceed 220A for more than 1 minute.

E010	Smart Port 1 OCP	Smart Port 1 has overcurrent protection	Verify the load on SP1 does not exceed 137.5A for more than 1 minute.
E011	Smart Port 2 OCP	Smart Port 2 has overcurrent protection	Verify the load on SP2 does not exceed 88A for more than 1 minute.
E012	Smart Port 3 OCP	Smart Port 3 has overcurrent protection	Verify the load on SP3 does not exceed 66A for more than 1 minute.
E013	Smart Port 4 OCP	Smart Port 4 has overcurrent protection	Verify the load on SP4 does not exceed 66A for more than 1 minute.

11.3 WARNING CODES

CODE	INFO	DESCRIPTION	RECOMMENDATION
W000	Parallel comm fault	Parallel CAN communication fault	Check the parallel CAN cable between the GridBOSS and the master inverter.
W003	Load Shedding Overload	The smart load power exceeds the configured load shedding power limit	The port will resume operation, and the error will reset once the smart load power is below the configured load shedding power limit.
W006	RSD Active	RSD is active in the system	Turn off the RSD switch to restart the system.
W015	A trip by Gen Freq or Voltage abnormal	<ol style="list-style-type: none"> The generator frequency is not within 45~60Hz. The generator voltage is not within the range of (Grid Volt Limit 3 Low -10V) to (Grid Volt Limit 3 High+10V). 	Generator voltage and frequency must be within the supported range.
W016	No AC connection	No AC connection or power outage.	Verify the grid is up and that all grid breakers/switches are in the closed position.
W017	A trip by Vac abnormal	<ol style="list-style-type: none"> The grid voltage exceeds the protection voltage range of Grid Volt Limits 1, 2, and 3, and the duration exceeds the specified Grid Volt Limit Time for Grid Volt Limits 1, 2, and 3. The moving average value of the grid voltage exceeds the maximum allowable limit defined by the Grid Volt Mov Avg High safety regulation. 	Verify that the grid voltage is within the supported range.
W018	A trip by Fac abnormal	The grid frequency exceeds the Grid Freq Limits 1, 2, and 3, and the duration exceeds the specified Grid Freq Limit Time 1, 2, and 3.	Verify that the grid frequency is within the supported range.

11.4 INTERNAL FUSE REPLACEMENT

GridBOSS contains two internal fuses that protect the unit from overcurrent situations. One fuse protects line 1, and the other protects line 2. If a fuse needs to be replaced, follow the steps listed below. Before starting the replacement procedure, locate the two extra fuses shipped with the GridBOSS.



DANGER:

Before working on the unit, verify that all breakers are in the off position and that there is no voltage or current at each breaker and lug connection point.

1. The front inner black cable box cover must be removed to obtain access to the fuse area. Open the front door by releasing the three clasps on the right side of the unit. Next, remove the four screws as identified in the image below and then carefully remove the inner black cable box cover by lifting it out of the chassis.



2. Remove the internal orange cover by first removing the two nuts using a 7mm socket and the four screws using a Phillips screwdriver. Then, lift the cover out of the unit.



3. Locate the two internal fuses outlined in blue in the image below.

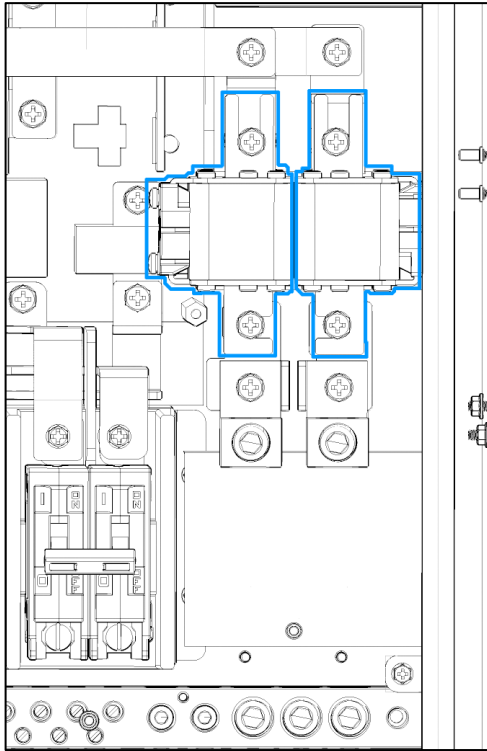

4. Remove the M6 screws (2 per fuse) as indicated by the blue arrows. Then, remove each fuse.

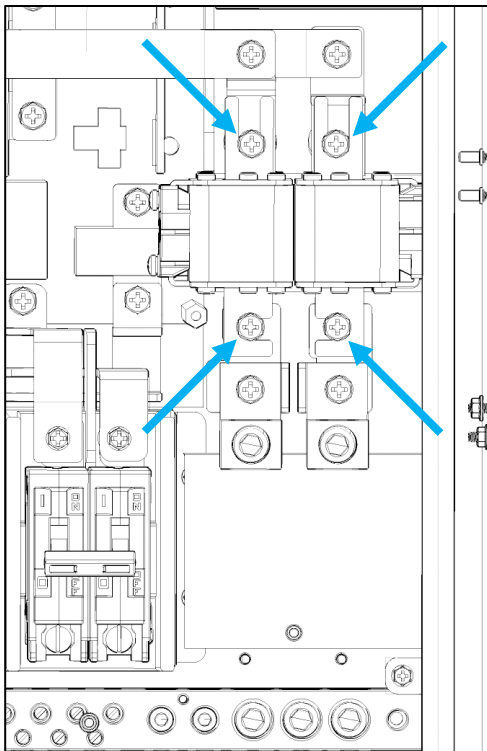

5. Set the new fuse in place. Verify that the direction of the fuse matches the image below. The smaller notch open to the side should be towards the grid input, and the longer notch open on the end should be towards the inside of the chassis.



6. Reinstall the four M6 screws and tighten to 80 in-lbs. (9.0Nm).



NOTE: Verify that the plastic insulator is positioned between the fuses before securing them.

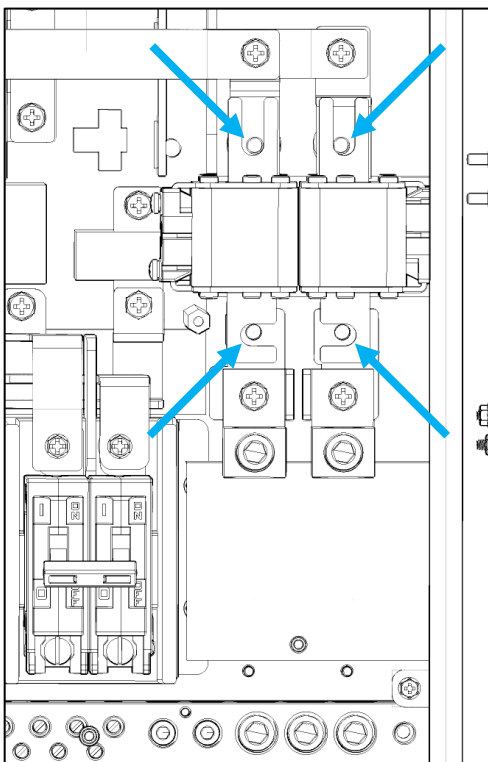

7. Reinstall the orange inner cover plate removed in step 2.
8. Reinstall the inner black cable box cover that was removed in step 1.
9. The system is now ready for use.

12. CHANGELOG

v1.2.1

- Updated slave inverter DIP switches from up position (ON) to down position (OFF).

v1.2.0

- Changed FlexBOSS18 breaker size to 70A on pages 1, 18, 19, and 31.
- Added QR code to the Hybrid Inverter RSD Wiring Guide on page 33.

v1.1.9

- Added specific model informational callouts to the specifications on page 2.

v1.1.8

- Added hardware versioning information in the product overview section.
- Added SOC + Time to the smart port settings and example configurations.

v1.1.7

- Added software limited to 200A in the spec sheet for the internal bus rating.
- Fixed the Eaton main description to list the part number followed by its rating correctly.
- Added FlexBOSS18 as a supported hybrid inverter
- Add additional versions of the anti-twist plate in the main lug area under main breaker install.
- Updated the no grid sell back image on page 39.
- Updated error codes in section 11.2
- Changed communications cable max length to 260 feet (80 meters).

v1.1.6

- Changed ambient operating temperature on page 1 to -40°F – 113°F (-40°C – 45°C) on page 1 and on page 10.
- Removed (pending) from FCC Part 15, Class B on page 2.
- Changed small knockout diameter from 0.90 to 1.14 in. on page 8.
- Updated wire size and torque values in section 6.5.
- A note was added to verify that the anti-twist plates are properly installed when adding a main breaker on page 18.
- Added generator 2-wire start specifications on page 24.
- Updated RSD information to read the external switch must be connected in series on page 29.
- Updated RSD information to state smart ports & backed-up loads are disabled when RSD is initiated.
- Changed no grid sell-back configuration to include powering non-backup load port on page 36.
- Changed grid relay to open in Off-Grid mode image on page 38.
- Removed Mid Box from the settings area and replaced it with Battery Control on pages 39 – 44.
- Removed Mid Box from the settings area and replaced it with Grid Boss on pages 39 – 44.
- Adjusted smart port configurations to include the “Smart Load Based on” setting on page 42 and page 52.
- Updated Smart Load End Time description on page 53.
- Updated AC Couple setting descriptions on page 54.
- Changed configuration images to reflect using the working modes area of the Monitor Center.
- Updated error and warning codes in sections 11.2 and 11.3.
- Updated the GridBOSS renders to the all silver chassis.

v1.1.5

- Modified wording in Section 5.5 p.23 Generator Port. Value changed from 3% to 12%.
- Changed the shipping hybrid port breaker to 90A
- Removed requirement for shared battery when using more than one inverter with GridBOSS.
- Added fault and warning codes to section 11.

v1.1.4

- Modified cover image to reflect new coat and logo

v1.1.3

- Modified the relays and jump-over line (cable) in the GridBOSS product overview and configuration examples diagrams.
- Added steps to replace the internal fuses under section 11.2.
- Changed mounting angle images in section 6.1.
- Changed recommended torque specification for the 30A – 125A breakers.
- Changed Product Overview into a main section and added labeling of chassis features.
- Added information that Dry 2 contacts are reserved and unused at this time.
- Updated smart load and AC coupling configuration information in sections 7 and 9.
- Added off-grid configuration example in section 6.1.
- Updated Monitor Center main page image to reflect the Monitor Center update.
- Added idle consumption and transfer time data.
- Corrected link for the QR code on the front page.
- Added ground and neutral torque settings.
- Updated minimum FW for inverters when connected to GridBOSS
- Updated GridBOSS enable settings and image in section 6.6
- Added torque wrench to the recommended tools list

v1.1.2

- Modified spec sheet FCC Part 15, Class B to read as (pending)
- Modified formatting throughout the document
- Added suggestion for users to follow UL514B when installing the unit in section 6.1
- Added breaker sizes included in the shipment to section 6.4
- Added table describing breaker use cases to section 6.4
- Added nominal knockout sizing table to section 6.4
- Added additional spacing information in section 6.1
- Added additional component compatibility for smart ports 3/4 in section 4.4
- Modified section numbering

v1.1.1

- Updated specifications table to include hybrid breaker sizes and unsupported inverter note.
- Added breaker installation section.

v1.1.0

- Initial document release



CONTACT US

support@eg4electronics.com

(903) 609-1988

www.eg4electronics.com