

EG4[®] CHARGEVERTER PLUS

USER MANUAL



TABLE OF CONTENTS

1.	TECHNICAL SPECIFICATIONS.....	1
2.	ABBREVIATIONS.....	2
3.	SAFETY.....	3
3.1	SAFETY INSTRUCTIONS.....	3
3.2	IMPORTANT SAFETY NOTIFICATIONS.....	3
4.	SÉCURITÉ GÉNÉRIQUE.....	5
4.1	CONSIGNES DE SÉCURITÉ.....	5
4.2	NOTIFICATIONS DE SÉCURITÉ IMPORTANTES.....	5
5.	BRIEF INTRODUCTION.....	7
5.1	PRODUCT OVERVIEW.....	7
5.2	PACKING LIST.....	8
6.	INSTALLATION.....	9
6.1	RECOMMENDED TOOLS.....	9
6.2	MOUNTING THE CHARGER.....	10
6.3	AC CONNECTIONS.....	11
6.4	DC CONNECTIONS.....	13
7.	OPERATION.....	19
7.1	POWER ON/OFF.....	19
7.2	DISPLAY PANEL OPERATION.....	19
7.3	CHARGER COMMUNICATIONS.....	27
7.4	WORKING WITH A GENERATOR.....	30
7.5	DRY CONTACT DESCRIPTION.....	31
8.	TROUBLESHOOTING AND MAINTENANCE.....	33
8.1	TROUBLESHOOTING.....	33
9.	MAINTENANCE.....	34
9.1	CLEANING THE FILTERS.....	34
10.	WARRANTY INFORMATION.....	35
11.	STORAGE.....	35
11.1	ENVIRONMENTAL FACTORS.....	35
12.	CHANGELOG.....	36

1. TECHNICAL SPECIFICATIONS

CHARGER OUTPUT SPECIFICATIONS

CHARGE CURRENT [ADJUSTABLE]	0 – 100A @ 240 VAC 0 – 50A @ 120 VAC 0 – 80A @ 208 VAC
CHARGE VOLTAGE [ADJUSTABLE]	40 – 60 VDC (default 40 VDC)
OUTPUT RIPPLE	<500mv
MAXIMUM OUTPUT	5120W @ 240 VAC 2560W @ 120 VAC

AC INPUT SPECIFICATION

AC INPUT VOLTAGE RANGE	90 – 264 VAC
AC FREQUENCY	50 – 60Hz
MAXIMUM INPUT CURRENT	26A @ 240 VAC 28A @ 120 VAC
IDLE CONSUMPTION	~4W

ENVIRONMENTAL SPECIFICATIONS

OPERATING TEMPERATURE RANGE	-40° – 131°F (-40° – 55°C)
STORAGE TEMPERATURE RANGE	-40° – 158°F (-40° – 70°C)
HUMIDITY	5% – 95% relative humidity (non-condensing)
INGRESS PROTECTION	IP54
OPERATING ALTITUDE	0 – 9843 ft. (0 – 3000 m)

DRY CONTACT SPECIFICATIONS

INTERFACE CONNECTOR	NO, NC, and C
---------------------	---------------

GENERAL SPECIFICATIONS

BATTERY COMPATIBILITY	15s or 16s Cell Lithium Batteries
COMMUNICATION PORT	CAN/RS485 (RJ45)
DIMENSION H × W × D	4.3 × 16.1 × 7.1 in. (110 × 410 × 180 mm)
NET WEIGHT	13.67 lbs. (6.2 kg)
CERTIFICATIONS	UL1012, FCC CLASS B
NOISE	<65db
WARRANTY	3 years* (only when used indoors)

*For information regarding warranty registration on EG4® Electronics products, please navigate to <https://eg4electronics.com/warranty/> and select the corresponding product to begin the registration process.

2. ABBREVIATIONS

- AWG – American Wire Gauge
- A – Amps
- Ah – Amp hour(s)
- AC – Alternating Current
- AFCI – Arc-Fault Circuit Interrupter
- AHJ – Authority Having Jurisdiction
- kAIC – kilo-Amp Interrupting Capability
- ANSI – American National Standards Institute
- BAT – Battery
- BMS – Battery Management System
- COM – Communication
- CT – Current Transformer
- DC – Direct Current
- DIP – Dual In-line Package
- DOD – Depth of Discharge
- EG – Equipment Ground
- EGS – Equipment Grounding System
- EMC – Electromagnetic Compatibility
- EPS – Emergency Power System
- ESS – Energy Storage System
- E-Stop – Emergency Stop
- FCC – Federal Communication Commission
- GE – Grounding Electrode
- GEC – Grounding Electrode Conductor
- GFCI – Ground Fault Circuit Interrupter
- GFDI – Ground Fault Detector/Interrupter
- Imp – Maximum Power Point Current
- IEEE – Institute of Electrical and Electronic Engineers
- IP – Ingress Protection
- I_{sc} – Short-Circuit Current
- In-lbs. – Inch Pounds
- kW – Kilowatt
- kWh – Kilowatt-hour
- LCD – Liquid Crystal Display
- LFP – Lithium Iron Phosphate
- L1 – Line 1
- L2 – Line 2
- mm – Millimeters
- MPPT – Maximum Power Point Tracking
- mV – Millivolt
- N – Neutral
- NEC – National Electric Code
- NEMA – National Electrical Manufacturers Association
- NFPA – National Fire Prevention Association
- Nm – Newton Meters
- NOCT – Normal Operating Cell Temperature
- PC – Personal Computer
- PCB – Printed Circuit Board
- PE – Protective Earth
- PPE – Personal Protective Equipment
- PV – Photovoltaic
- RSD – Rapid Shut Down
- SCC – Standards Council of Canada
- SOC – State of Charge
- STC – Standard Testing Conditions
- UL – Underwriters Laboratories
- UPS – Uninterrupted Power Supply
- V – Volts
- VOC – Open-Circuit Voltage
- VMP – Voltage Maximum Power

3. SAFETY

3.1 SAFETY INSTRUCTIONS

Before any work begins, carefully read all safety instructions, and always observe them when working on or with the battery. The installation must follow all applicable national and local standards and regulations. Consult with the local AHJ and/or utility to obtain the proper permits and permissions before installation.

Incorrect installation may cause:

- *Injury or death to the installer, operator or third party*
- *Damage to the battery or other attached equipment*

3.2 IMPORTANT SAFETY NOTIFICATIONS



DANGER! Hazardous Voltage Circuits!

There are various safety concerns that must be carefully observed before, during, and after the installation, as well as during future operation and maintenance. The following are important safety notifications for the installer and any end users of this product under normal operating conditions.

1. **Do not disassemble the charger or battery.** Contact the distributor for any issues that need repair for more information and proper handling instructions. Incorrect servicing or re-assembly may result in a risk of electric shock or fire and void the warranty.
2. **Never short-circuit DC inputs.** Short-circuiting the battery may result in a risk of electric shock or fire and can lead to severe injury or death and/or permanent damage to the unit and/or any connected equipment.
3. **Use caution when working with metal tools on or around batteries and systems.** Risk of electrical arcs and/or short circuiting of equipment can lead to severe injury or death and equipment damage.
4. **Beware of high battery current.** Ensure that the battery module breakers and/or on/off switches are in the “open” or “off” position before installing or working on the battery. Use a voltmeter to confirm there is no voltage present to avoid electric shock.
5. **Do not make any connections or disconnections to the system while the batteries are operating.** Damage to system components or risk of electrical shock may occur if working with energized batteries.
6. Make sure the charger and battery are properly grounded.
7. An installer should make sure to be well protected by reasonable and professional insulative equipment [e.g., personal protective equipment (PPE)].
8. Before installing, operating, or maintaining the system, it is important to inspect all existing wiring to ensure it meets the appropriate specifications and conditions for use.
9. Ensure that the battery and system component connections are secure and proper to prevent damage or injuries caused by improper installation.
10. To reduce risk of electrical shock, disconnect the AC source and DC load before attempting maintenance or troubleshooting.

**WARNING:****TO REDUCE THE RISK OF INJURY, READ ALL INSTRUCTIONS!**

All work on this product (system design, installation, operation, setting, configuration, and maintenance) must be carried out by qualified personnel. To reduce the risk of electric shock, do not perform any servicing other than those specified in the operating instructions unless qualified to do so.

11. Read all instructions before commencing installation. For electrical work, follow all local and national wiring standards, regulations, and these installation instructions. All wiring should be in accordance with the National Electrical Code (NEC), ANSI/NFPA 70.
12. The battery and system can connect with the utility grid only if the utility provider permits. Consult with the local AHJ before installing this product for any additional regulations and requirements for the area.
13. All warning labels and nameplates on this battery should be clearly visible and must not be removed or covered.
14. The installer should consider the safety of future users when choosing the battery's correct position and location as specified in this manual.
15. Keep children away from touching or misusing the battery and relevant systems.

The battery is designed to stop charging when reaching the low temperature threshold of 32°F. If charging current is observed when the internal battery temperature is below 32°F, disconnect battery immediately and consult the distributor.

**WARNING!**

Cancer and Reproductive Harm – See www.P65Warnings.ca.gov for more details.

DISCLAIMER

EG4® reserves the right to make changes to the material herein at any time without notice. Please refer to www.eg4electronics.com for the most updated version of our manuals/spec sheets.

4. SÉCURITÉ GÉNÉRIQUE

4.1 CONSIGNES DE SÉCURITÉ

Avant de commencer tout travail, lisez attentivement toutes les consignes de sécurité et respectez-les toujours lorsque vous travaillez sur ou avec la batterie. L'installation doit être conforme à toutes les normes et réglementations nationales ou locales applicables. Consultez l'autorité compétente locale et/ou le service public pour obtenir les permis et les autorisations appropriés avant l'installation.

Une installation incorrecte peut entraîner les effets suivants :

- Blessure ou décès de l'installateur, de l'exploitant ou d'un tiers
- Dommages à la batterie ou à tout autre équipement attaché

4.2 NOTIFICATIONS DE SÉCURITÉ IMPORTANTES



DANGER: CIRCUITS À HAUTE TENSION!

Il existe divers problèmes de sécurité qui doivent être soigneusement observés avant, pendant et après l'installation, ainsi que lors de l'utilisation et de la maintenance futures. Ce qui suit sont des notifications de sécurité importantes pour l'installateur et tout utilisateur final de ce produit dans des conditions de fonctionnement normales.

1. **Ne démontez pas le chargeur ou la batterie.** Contactez le distributeur pour tout problème nécessitant une réparation pour plus d'informations et des instructions de manipulation appropriées. Un entretien ou un remontage incorrect peut entraîner un risque de choc électrique ou d'incendie et annuler la garantie.
2. **Ne court-circuitez jamais les entrées CC.** Un court-circuit de la batterie peut entraîner un risque de choc électrique ou d'incendie et peut entraîner des blessures graves ou la mort et/ou des dommages permanents à l'appareil et/ou à tout équipement connecté.
3. **Soyez prudent lorsque vous travaillez avec des outils métalliques sur ou autour des batteries et des systèmes.** Le risque d'arcs électriques et/ou de court-circuit de l'équipement peut entraîner des blessures graves ou la mort et des dommages à l'équipement.
4. **Méfiez-vous du courant élevé de la batterie.** Assurez-vous que les disjoncteurs du module de batterie et/ou les interrupteurs marche/arrêt sont en position « ouvert » ou « éteint » avant d'installer ou de travailler sur la batterie. Utilisez un voltmètre pour confirmer qu'il n'y a pas de tension afin d'éviter les chocs électriques.
5. **N'effectuez pas de connexions ou de déconnexions au système pendant que les piles fonctionnent.** Des dommages aux composants du système ou un risque de choc électrique peuvent survenir si vous travaillez avec des batteries sous tension.
6. Assurez-vous que le chargeur et la batterie sont correctement mis à la terre.
7. Un installateur doit s'assurer d'être bien protégé par un équipement isolant raisonnable et professionnel [p. ex., équipement de protection individuelle (EPI)].
8. Avant d'installer, d'exploiter ou d'entretenir le système, il est important d'inspecter tout le câblage existant pour s'assurer qu'il répond aux spécifications et aux conditions d'utilisation appropriées.
9. Assurez-vous que les connexions de la batterie et des composants du système sont sûres et appropriées pour éviter les dommages ou les blessures causés par une mauvaise installation.
10. Pour réduire le risque de choc électrique, débranchez la source CA et la charge CC avant de tenter l'entretien ou le dépannage.



AVERTISSEMENT : POUR RÉDUIRE LE RISQUE DE BLESSURE, LISEZ TOUTES LES INSTRUCTIONS !

Tous les travaux sur ce produit (conception du système, installation, exploitation, réglage, configuration et maintenance) doivent être effectués par du personnel qualifié. Pour réduire le risque de choc électrique, ne réalisez aucun entretien autre que ceux spécifiés dans les instructions de fonctionnement, sauf si vous êtes qualifié pour le faire.

11. Lisez toutes les instructions avant de commencer l'installation. Pour les travaux électriques, suivez toutes les normes de câblage locales et nationales, les réglementations et ces instructions d'installation. Tout le câblage doit être conforme au Code national de l'électricité (NEC), ANSI/NFPA 70.
12. La batterie et le système ne peuvent se connecter au réseau public que si le fournisseur d'électricité l'autorise. Consultez l'AHJ local avant d'installer ce produit pour connaître les réglementations et exigences supplémentaires de la région.
13. Toutes les étiquettes d'avertissement et les plaques signalétiques de cette batterie doivent être clairement visibles et ne doivent pas être retirées ou couvertes.
14. L'installateur doit tenir compte de la sécurité des futurs utilisateurs lors du choix de la position et de l'emplacement corrects de la batterie, comme spécifié dans ce manuel.
15. Tenez les enfants à l'écart de la batterie et des systèmes concernés ou de les utiliser à mauvais escient.

La batterie est conçue pour arrêter de se charger lorsqu'elle atteint le seuil bas de 32°F. Si un courant de charge est observé lorsque la température interne de la batterie est inférieure à 32°F, débranchez immédiatement la batterie et consultez le distributeur.



AVERTISSEMENT !

Cancer et troubles de la reproduction – Voir www.P65Warnings.ca.gov pour plus de détails.

DISCLAIMER

EG4® se réserve le droit de modifier le contenu de ce document à tout moment sans préavis. Veuillez consulter www.eg4electronics.com pour la version la plus récente de nos manuels/fiches techniques.

5. BRIEF INTRODUCTION

This guide describes the installation and operation of the EG4® Chargeverter Plus. Read the guide carefully and completely before proceeding.

5.1 PRODUCT OVERVIEW

The Chargeverter Plus is a robust AC-to-DC converter and charger designed specifically for 48 VDC lithium battery charging in **on-grid and off-grid Energy Storage System (ESS)**. The charger can operate on 120, 208, or 240 VAC and is capable of **delivering up to 100A** of DC charging current. The unit is rated IP54, providing protection from dust and small amounts of splashing water. The inputs, outputs, and interface controls are identified in the table and image below.

NO.	DESCRIPTION	NO.	DESCRIPTION
1	Charging indicator	8	Battery breaker
2	Power indicator	9	Mounting bracket (x2)
3	LCD interface	10	Positive battery quick connector
4	Function button – ESC (Escape)	11	Negative battery quick connector
5	Function button – UP	12	Dry contact port
6	Function button – DOWN	13	CAN/RS485 Communication Port (RJ45)
7	Function button – ENTER	14	AC input connector

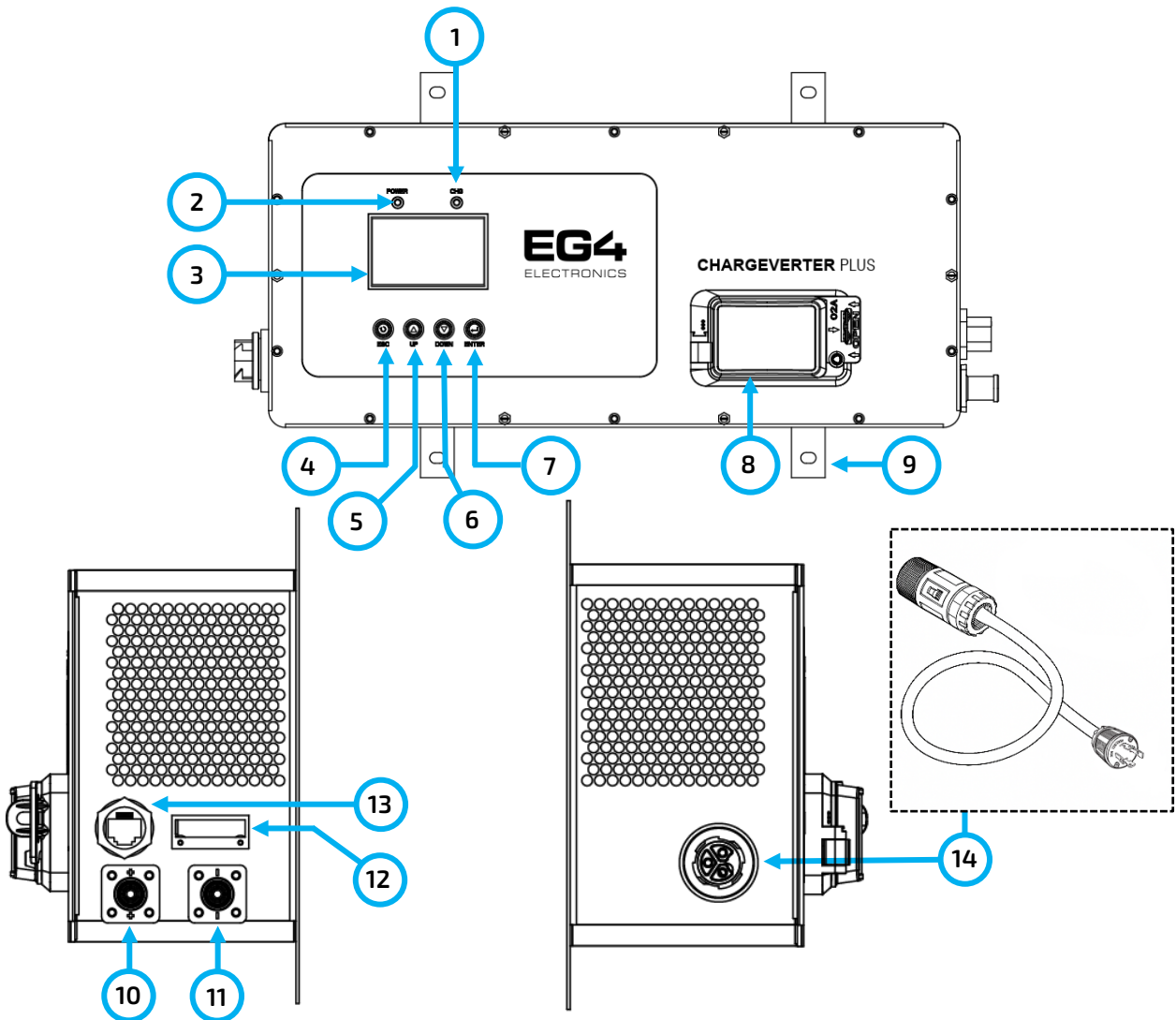

5.2 PACKING LIST

Before installation, inspect the unit. Be sure that nothing inside the package is damaged. The following items will arrive in the shipment.

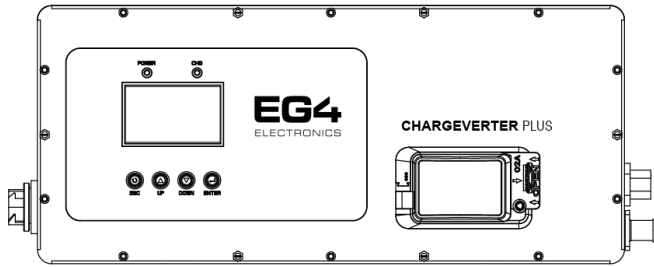

Chargeverter Plus

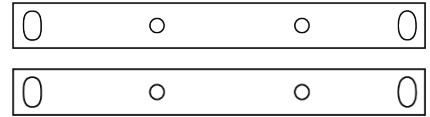

Mounting Brackets (x2)

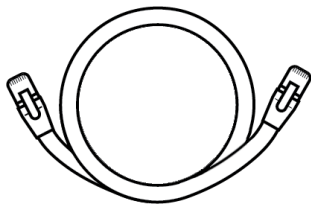

CAN/RS485
Communication Cable
(RJ45 to RJ45)

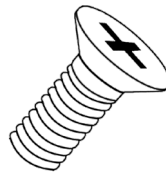

M4*8mm Mounting
Screws (x5)

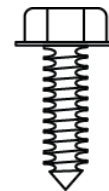

M4*40mm Bracket
Screws (x5)

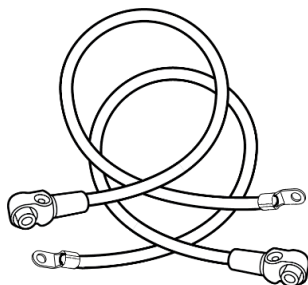

Positive (Red) and
Negative (Black) 4 AWG
Battery Cables

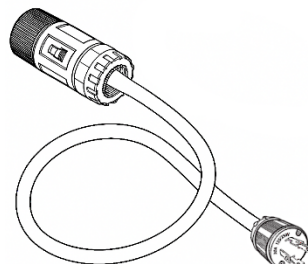

Power Supply Cord

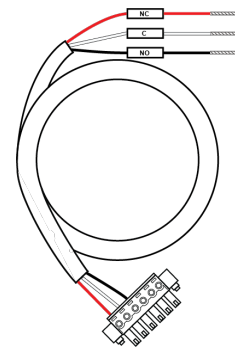

Dry Contact Cable

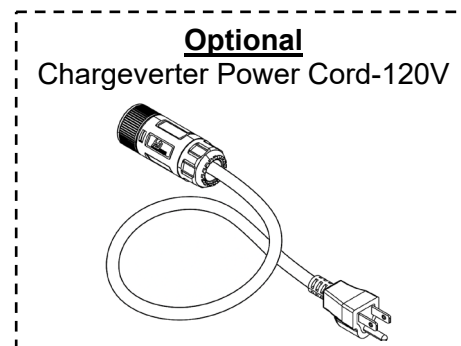
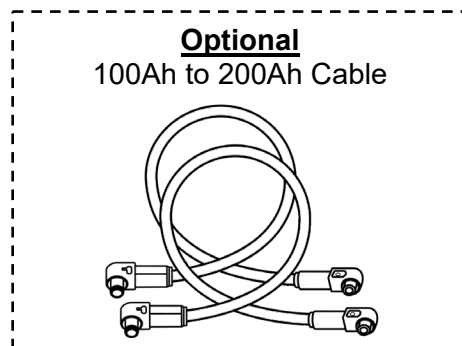

6. INSTALLATION

6.1 RECOMMENDED TOOLS

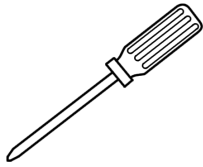

Phillips Head
Screwdriver



Safety
Goggles

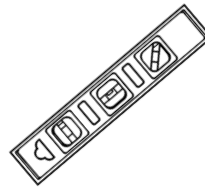

Level



Gloves



Electric Drill

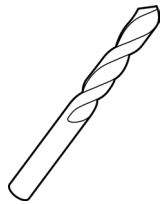

Drill Bit

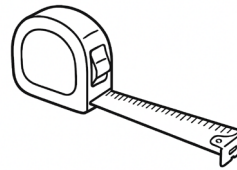

Tape Measure



Dielectric
Shoes

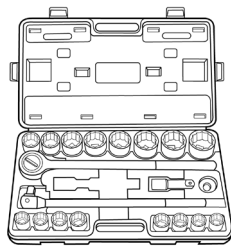

Socket Set

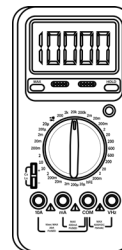

Multimeter

6.2 MOUNTING THE CHARGER

When selecting where to install the charger:

- Verify the mounting surface is suitable for mounting according to the design requirements shown below. Do not mount the EG4® Chargeverter Plus on combustible or flammable surfaces.
- Mount the Chargeverter Plus on a vertical, structurally sound wall.
- Install in a location that allows the LCD interface to be easily viewed.
- The ambient temperature should be between -40° – 131°F (-40° – 55°C) to ensure optimal operation.
- Verify there is at least 11.8 in. (300 mm) above and below and 23.6 in. (600 mm) on each side of the unit for heat dissipation and space for wires.

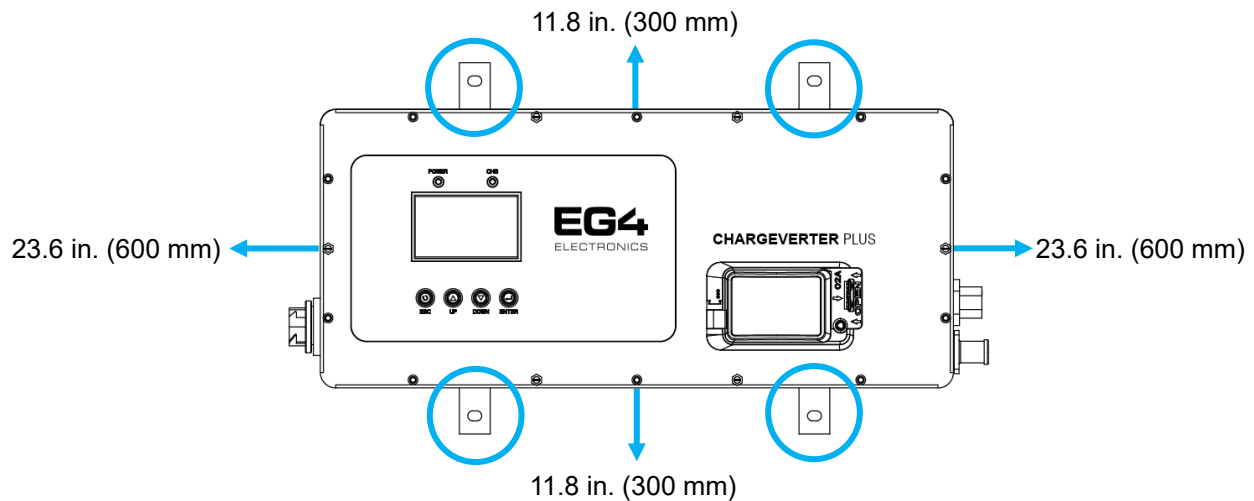

INSTALLATION STEPS

1. Install the 2 mounting brackets to the back of the Chargeverter with the four M4*8mm screws provided with the unit.
2. Level and mount the charger to an appropriate wall by securing it with the four M4*40mm screws provided with the unit.



NOTE:

Other fastening methods are acceptable as long as the weight of the charger (13.67 lbs. [6.4kg]), is adequately supported (e.g. concrete anchors, toggle bolt anchors, lag bolts, wood screws, etc.).



HOT:

The EG4® Chargeverter Plus can produce temperatures of more than 131°F (55°C). It is recommended to mount this unit on appropriate backing, such as cement board, with 11.8 in. (300 mm) on top and bottom and 23.6 in. (600 mm) left to right clearance around the unit to allow proper airflow. **DO NOT BLOCK THE AIR VENTS!**

6.3 AC CONNECTIONS

The EG4® Chargeverter Plus comes pre-wired with a NEMA L14-30P 4-prong male twist lock plug designed to be used on a 240V/30A circuit, as shown in the images below:

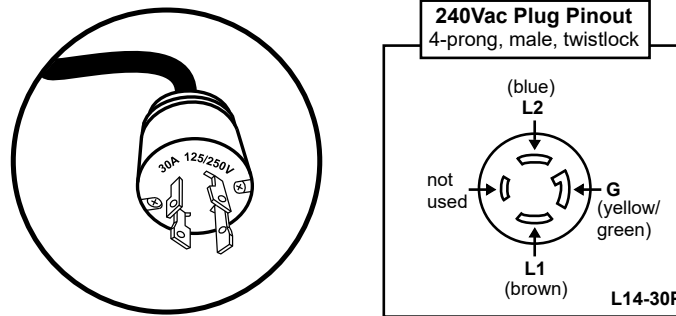

The EG4® Chargeverter Power Cord – 120V (optional accessory, not included) is designed to support a 120V/15A input source and deliver up to 25A / 1425W of battery charging power.

This cord enables operation from a standard 120V receptacle, providing a convenient charging solution in applications where 240V input power is not available.

Optional Chargeverter Power Cord-120V

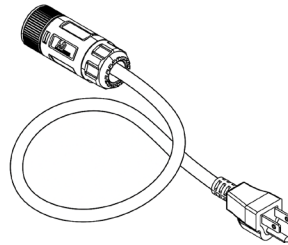

Additional pinouts for other common NEMA 120V/30A and 208V/30A circuits are provided on page 12 for reference.



WARNING:

Plug pinouts are provided for reference only. Consult a qualified professional before making any modifications.

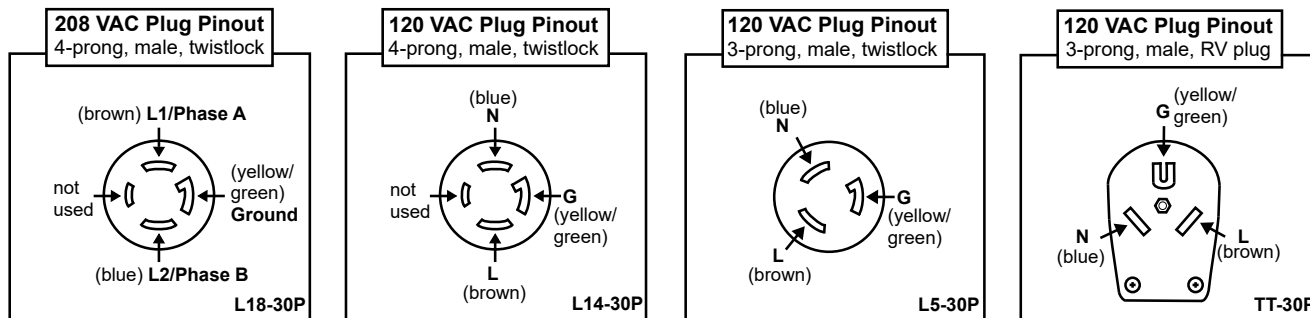

CHARGEVERTER AC WIRE COLOR	120V	208V	240V
Brown	L1 (Hot)	L1 (Phase A)	L1
Blue	Neutral	L2 (Phase B)	L2
Yellow/Green	Ground	Ground	Ground

The charger's maximum output current is dependent on the input AC voltage as shown in the following table:

CHARGEVERTER AC INPUT	MAXIMUM DC OUTPUT CURRENT
120 VAC/28A	50A
208 VAC/26A	80A
240 VAC/26A	100A



NOTE:

For single phase 230 VAC installations, follow the guidelines below to properly wire the appropriate plug to the Chargeverter Plus.

CHARGEVERTER AC WIRE COLOR	DESCRIPTION
Brown	230 VAC
Blue	Neutral
Yellow/Green	Ground

6.4 DC CONNECTIONS



WARNING:

Verify that the battery breakers and/or battery switches are in the OFF position and the charger is not plugged in while installing battery charging cables.

- For a single battery, connect the cables to the battery positive and negative terminals or for a battery bank, connect the cables to the positive and negative busbars using appropriate size bolts for the battery.
- Verify EG4® Chargeverter Plus cable ring terminals are attached to the battery terminals or busbar with the proper polarity and tighten to the proper torque specifications. See the battery documentation for these specifications.
- For 240V usage, plug the Chargeverter into a 240V/30A twist lock receptacle with a dedicated 30A double-pole breaker.
- For 208V usage, plug the Chargeverter into a 208V/30A receptacle with a dedicated 30A double-pole breaker.
- For 120V usage, plug the Chargeverter into a 120V/30A receptacle with a dedicated 30A single-pole breaker.



NOTE:

See plug pinouts in section 6.3 for common plug types.

EXAMPLE DIAGRAMS

The images below and on the next few pages showcase the EG4® Chargeverter Plus connected to different configurations of batteries.



NOTE:

Battery cable connections from Chargeverter Plus to the battery cabinet will connect to the busbar inside the battery cabinet. Check table below for torque values.

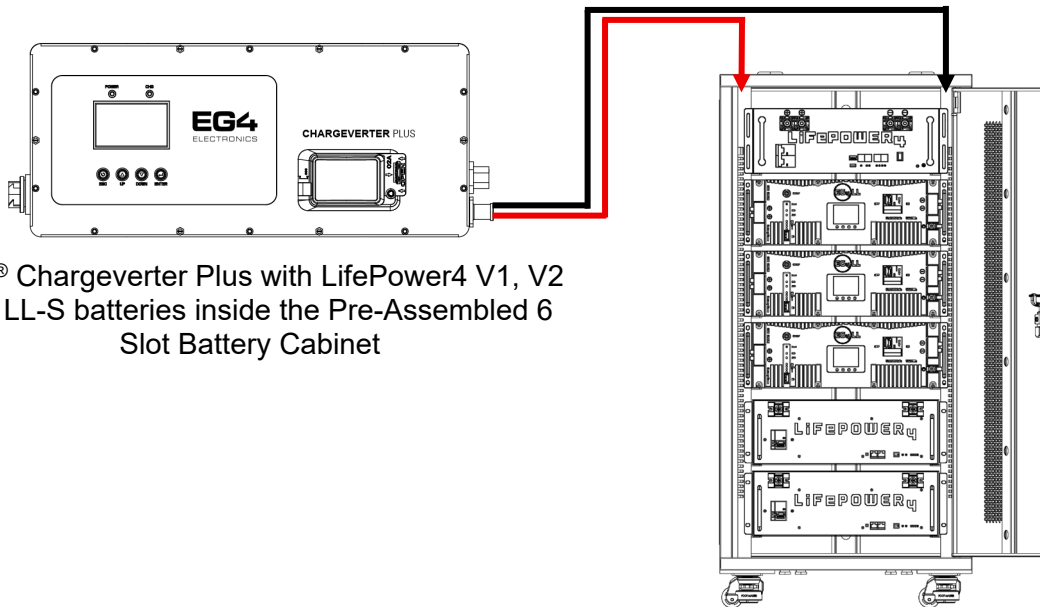

EG4® Chargeverter Plus with LifePower4 V1, V2 and LL-S batteries inside the Pre-Assembled 6 Slot Battery Cabinet

CABLE SIZE	MIN. INSULATOR VOLTAGE	TORQUE VALUE	MAX RECOMMENDED DISTANCE
2 AWG	600V	60 in-lbs. (~6.8 Nm)	15 ft. (4.6 m)

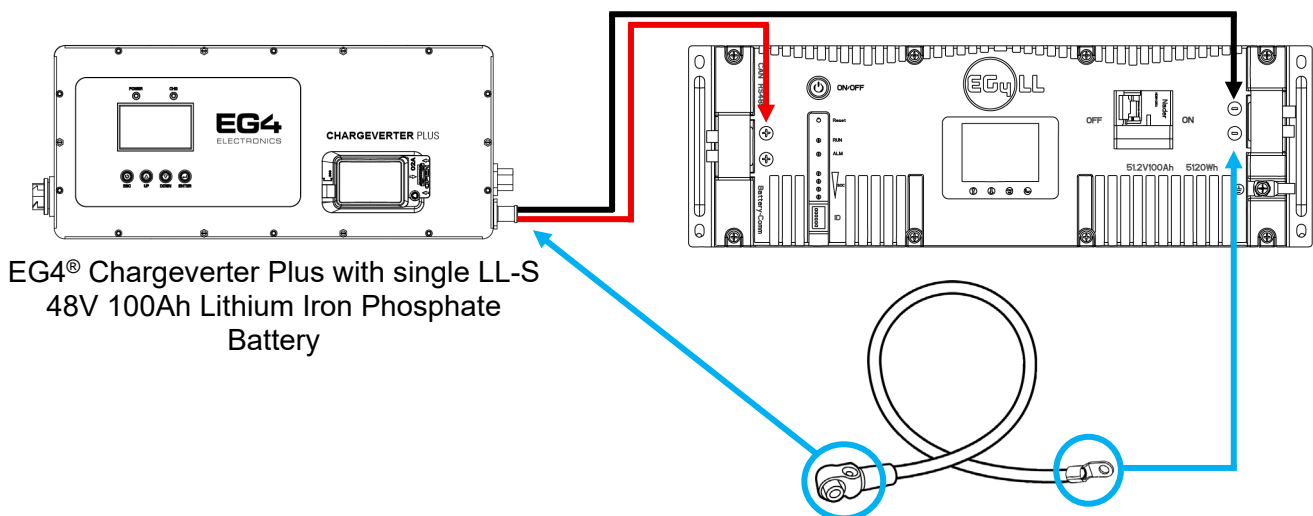

EG4® Chargeverter Plus with single LL-S 48V 100Ah Lithium Iron Phosphate Battery

The quick connect terminal will connect to the Chargeverter Plus and the ring terminal will connect to the battery terminal as shown in the picture above. Do not cross-polarize!

USING BUSBAR TO CONNECT CHARGEVERTER PLUS AND BATTERY

The EG4® Chargeverter Plus comes with battery cables that have a ring terminal on the end. The images below represent the connections that will have to be made to safely charge the WallMount Indoor and AW 280Ah and WallMount Indoor and AW 314Ah battery(s).



NOTE:

If end-user has purchased the optional 100Ah to 200Ah cable, see page 17 for image references.

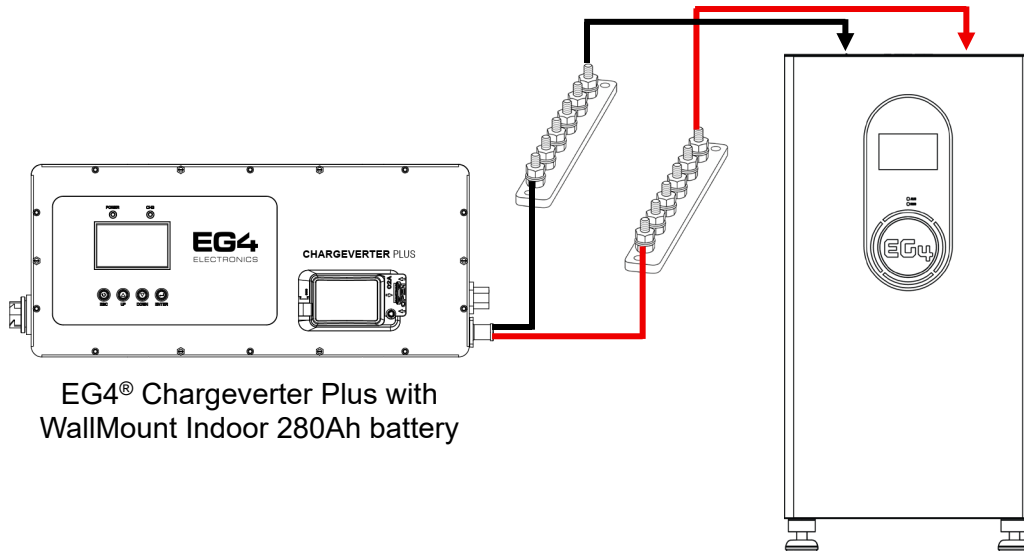

EG4® Chargeverter Plus with
WallMount Indoor 280Ah battery

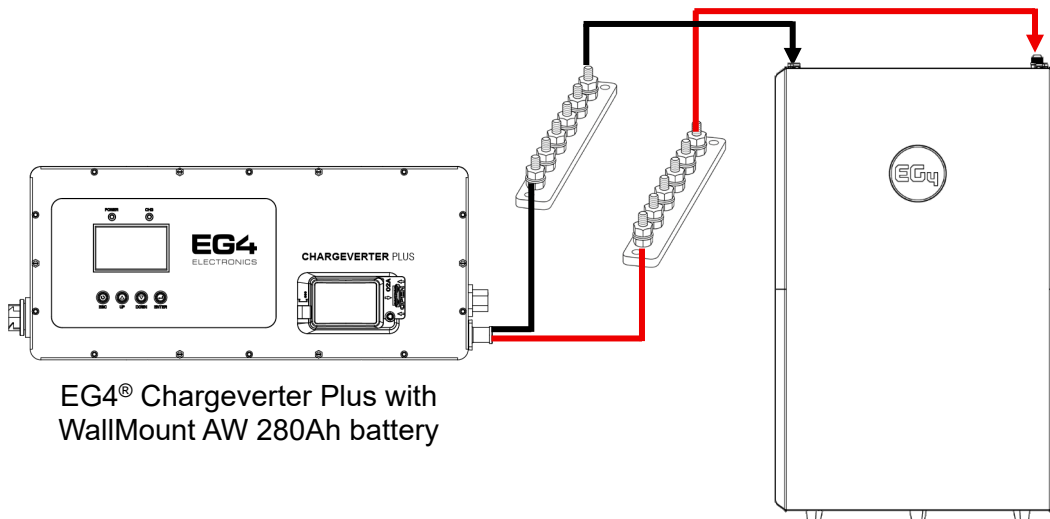

EG4® Chargeverter Plus with
WallMount AW 280Ah battery

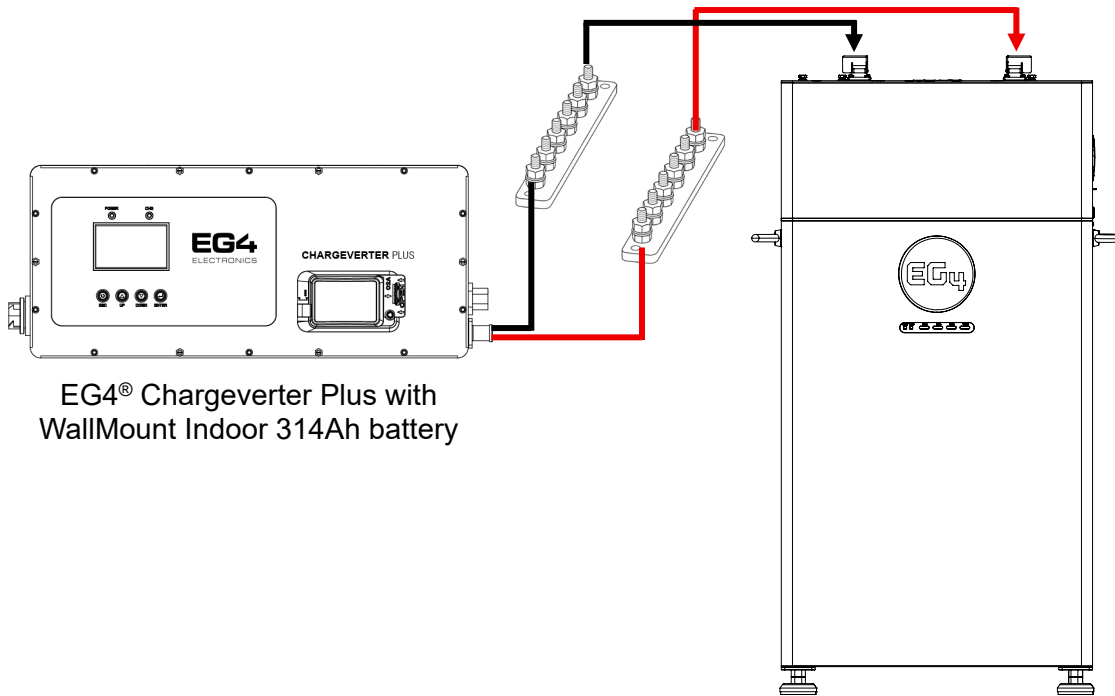

EG4® Chargeverter Plus with WallMount Indoor 314Ah battery

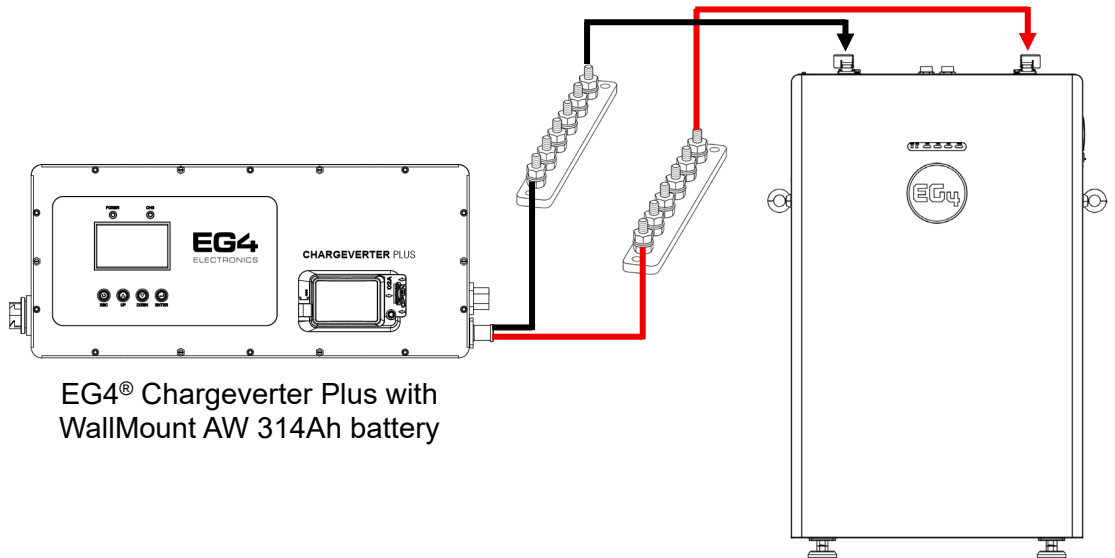

EG4® Chargeverter Plus with WallMount AW 314Ah battery

USING 100AH TO 200AH CABLE TO CONNECT CHARGEVERTER PLUS AND BATTERY

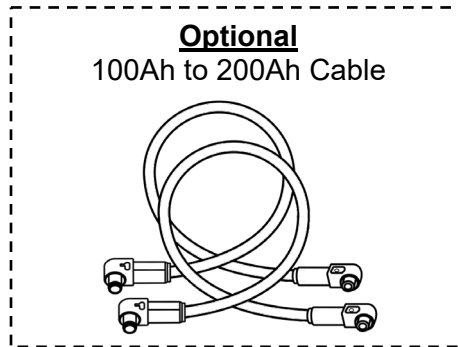

The 100Ah to 200Ah cable is EG4's solution to eliminate the use of busbars in connecting the Chargeverter Plus to the battery(s). This cable is designed to charge EG4® 280Ah and 314Ah Indoor and All Weather WallMount batteries.

If the end-user has purchased the optional 100Ah to 200Ah cable, busbars are no longer needed and can connect straight to the batteries shown below.

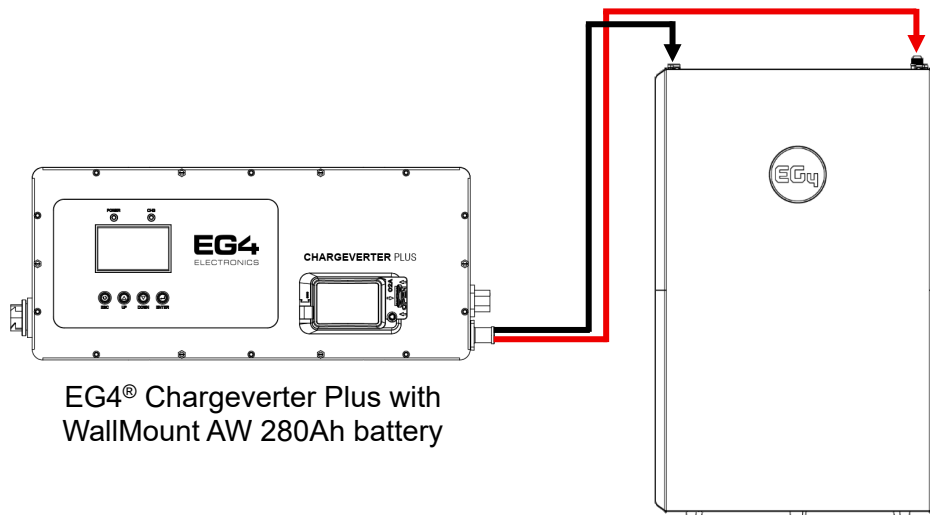
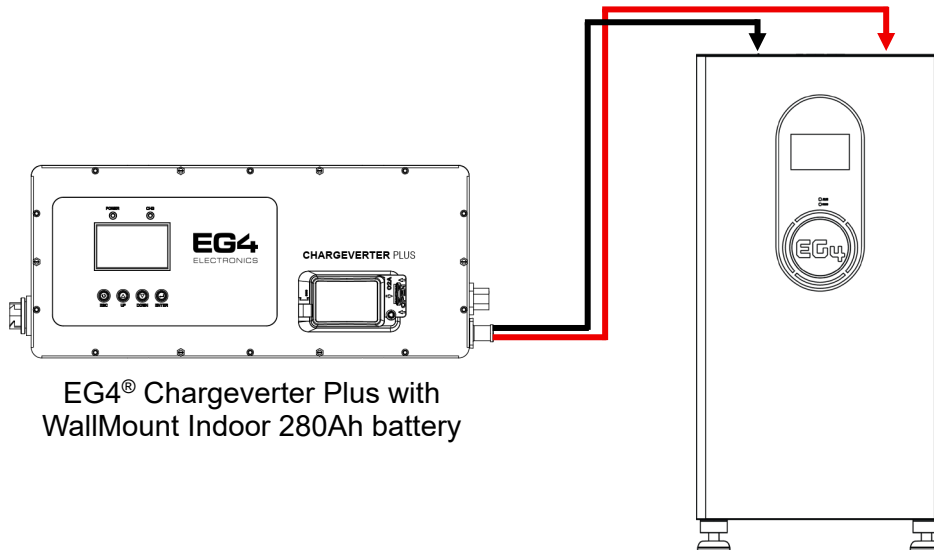

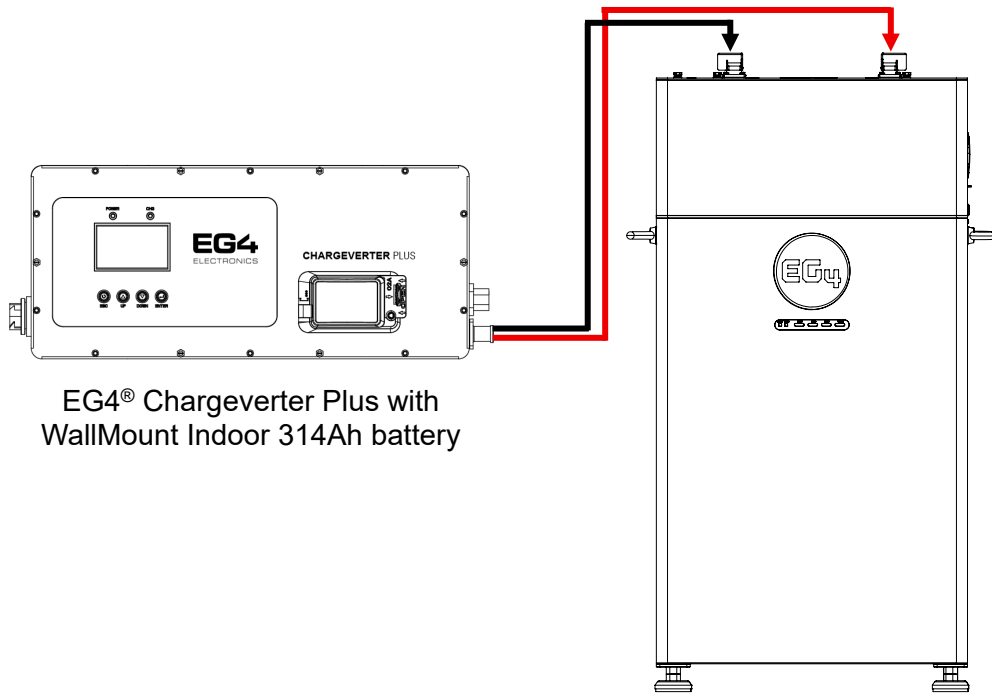

EG4® Chargeverter Plus with
WallMount Indoor 314Ah battery

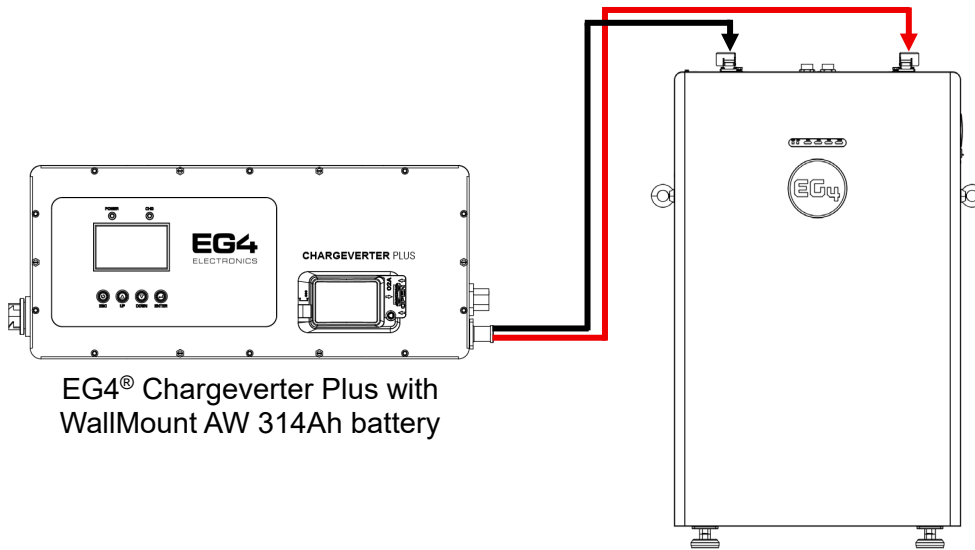

EG4® Chargeverter Plus with
WallMount AW 314Ah battery

7. OPERATION

7.1 POWER ON/OFF

1. Check that the battery cables are securely connected.
2. Verify the EG4® Chargeverter Plus is connected to a power supply capable of supplying the required voltage and amperage.
3. First turn on the battery breaker(s), wait for 5 seconds, then power on BMS.
4. Turn the Chargeverter breaker on the front of the unit to ON.

After the initial power-up, the end-user may need to set parameters to activate charging output.

If the required parameters are already configured, the Chargeverter will automatically start charging within 15 seconds.

7.2 DISPLAY PANEL OPERATION

Operation and control of the EG4 Chargeverter Plus are facilitated through the front panel (shown to the right). It features two green LED indicators, four function buttons, and an LCD interface indicating the operational and charging status of the unit. The following tables display the LED indicator modes and descriptions of the function-buttons.

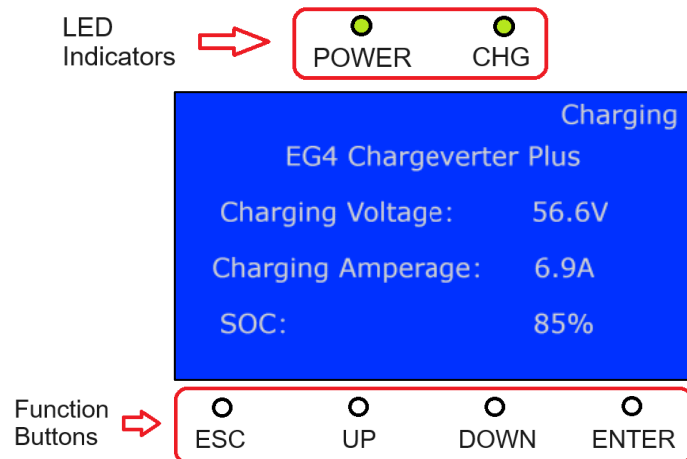

LED INDICATOR

LABEL	COLOR	STATUS	MODE
POWER	Green	Solid ON	The unit is powered ON.
CHG	Green	Solid ON	The battery is fully charged.
		Flashing	The battery is charging.

FUNCTION	DESCRIPTION
ESC	Exit Setting Mode.
UP	Increase the currently selected parameter. Go to the next selection to the left when navigating in Settings Mode. Note: The button shows an up arrow, but the function is “left” for navigating.
DOWN	Decrease the currently selected parameter. Go to the next selection to the right when navigating in Setting Mode. Note: The button shows a down arrow, but the function is “right” for navigating.
ENTER	Enter Setting Mode.
	Confirm the selection in Setting Mode.

LCD INTERFACE

Press any button to wake up the LCD interface. The main screen (shown to the right) displays the Charging Voltage, Charging Amperage, and SOC values. The SOC is only displayed when the charger is connected to a battery via CAN/RS485 and receives SOC information. This screen is informational only and no changes can be made.



NOTE:

SOC can only be used in closed-loop communication. Use voltage settings if SOC cannot be used.

Pressing the up and down keys on the main screen allows the user to switch pages and view the Version, Power Temp, Fan RPM, PSU Alarm, Charged kWh, and Hours Ran.

The main screen will display “LOST” for the SOC value when the charger is not connected to a battery via CAN/RS485 and is not receiving SOC data.

Charging	
EG4 Chargeverter Plus	
Charging Voltage:	56.6V
Charging Amperage:	6.9A
SOC:	85%

Charging		
Chargeverter Data		
Version	Power Temp	Fan RPM
P06S12M16	30°C	5000
PSU Alarm	Charged Kwh	Hours Ran
0000H	50	12

Charging	
EG4 Chargeverter Plus	
Charging Voltage:	56.6V
Charging Amperage:	6.9A
SOC:	LOST

When using the Chargeverter Plus, it will perform function conversion according to the working state, and the working status will appear in the upper right corner of the LCD display.

The working status is as follows:

- **Standby** – When the Chargeverter first powers on.

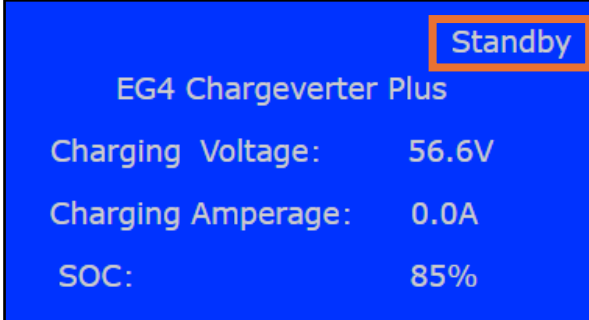

The image shows a blue LCD display with white text. In the top right corner, the word "Standby" is enclosed in an orange rectangular box. Below this, the text "EG4 Chargeverter Plus" is centered. Underneath, there are three lines of data: "Charging Voltage: 56.6V", "Charging Amperage: 0.0A", and "SOC: 85%".

EG4 Chargeverter Plus	
Charging Voltage:	56.6V
Charging Amperage:	0.0A
SOC:	85%

- **Generator Preheat** – Chargeverter will preheat the generator before auto starting.

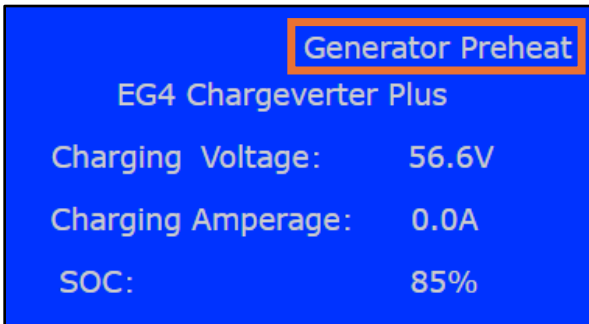

The image shows a blue LCD display with white text. In the top right corner, the words "Generator Preheat" are enclosed in an orange rectangular box. Below this, the text "EG4 Chargeverter Plus" is centered. Underneath, there are three lines of data: "Charging Voltage: 56.6V", "Charging Amperage: 0.0A", and "SOC: 85%".

EG4 Chargeverter Plus	
Charging Voltage:	56.6V
Charging Amperage:	0.0A
SOC:	85%

- **Generator Cooling** – Cool down after charging the battery(s). Beneficial for not overheating the generator.

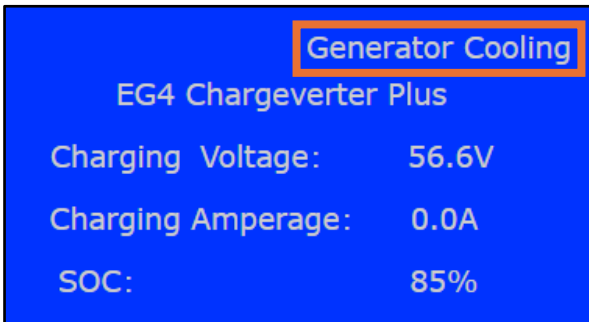

The image shows a blue LCD display with white text. In the top right corner, the words "Generator Cooling" are enclosed in an orange rectangular box. Below this, the text "EG4 Chargeverter Plus" is centered. Underneath, there are three lines of data: "Charging Voltage: 56.6V", "Charging Amperage: 0.0A", and "SOC: 85%".

EG4 Chargeverter Plus	
Charging Voltage:	56.6V
Charging Amperage:	0.0A
SOC:	85%

- **Discharging** – A state of idle.

Discharging	
EG4 Chargeverter Plus	
Charging Voltage:	56.6V
Charging Amperage:	0.0A
SOC:	85%

- **Charging** – When current is detected by the Chargeverter.

Charging	
EG4 Chargeverter Plus	
Charging Voltage:	56.6V
Charging Amperage:	6.9A
SOC:	85%

- **PSU Fault** – The “PSU Fault” indicator will activate when any of the following conditions occur; over-temperature protection, short-circuit protection, AC input over-voltage or under-voltage protection, fan failure, output over-voltage protection, PSU module communication failure.

PSU Fault	
EG4 Chargeverter Plus	
Charging Voltage:	56.6V
Charging Amperage:	0.0A
SOC:	85%

The table below describes the various parameters for the EG4® Chargeverter Plus; see the information on page 21 for details on how to make adjustments to the parameter settings.

PARAMETER	DESCRIPTION	APPLICATIONS	DETAILS
Voltage (V)	Charging Voltage	This parameter is used with and without a generator to set the charging voltage.	This is the voltage used to charge the batteries. The setting range is 40V – 60V in 1-digit increments per value. The default setting is 57V. EG4 recommends having at least a 5V difference between the BATT Start and BATT Stop.
SOC Start (%)	SOC Threshold	This parameter is used only when a generator is supplying AC power to the charger.	When the battery SOC is less than the SOC Start, the dry contacts NO & C are closed, and NC & C are open. This turns the generator ON. The setting range is 1% – 100% in 1% increments.
Voltage Start (V)	Battery Under-Voltage Threshold	This parameter is used only when a generator is supplying AC power to the charger.	When the battery voltage is lower than Voltage Start, the dry contacts NO & C are closed and NC & C are open. This turns the generator ON. The setting range is 40V – 60V in 1-digit increments.
Current (A)	Charging Current	This parameter is used with or without a generator to set the charging current.	This is the current used to charge the batteries. The setting range is 2A – 100A in 1A increments.
SOC Stop (%)	SOC Stop	This parameter is used only when a generator is supplying AC power to the charger.	When the battery SOC is higher than SOC Stop, the dry contacts NO & C are open. This turns the generator OFF. The setting range is 1% – 100% in 1% increments.
Voltage Stop (V)	Battery Over-Voltage Threshold	This parameter is used only when a generator is supplying AC power to the charger.	When the battery voltage is higher than Voltage Stop, the dry contacts NO & C are open and NC & C are closed. This turns the generator OFF. The setting range is 40V – 60V in 1-digit increments. Note: Upon reaching the Voltage Stop value, the Chargeverter will continue charging for ~3 minutes before stopping the charge.
Preheat Time	The preheating time can be set (0-5 minutes)	This parameter is used only when a generator is supplying AC power to the charger.	The preheating time can be set to 0 – 5 minutes. After starting the generator, the charger will not charge the battery during the preheating time.
Cooling Time	The cooling time can be set (0-5 minutes)	This parameter is used only when a generator is supplying AC power to the charger.	The cooling time can be set (0-5 minutes). After charging is completed, the charger will not charge the battery during the cooling time.

RS485 Protocol	RS485 Protocol	Select the protocol according to the communication interface of the battery.	<ol style="list-style-type: none"> 1. P01-GRW: PF Lithium battery BMS Communication Protocol RS485 Protocol 1xSxxP ESS V2.01 2. P02-LUX: 06-02-02-PTC Luxpower battery communication RS485 Protocol V03 20220706 3. P03-EG4: EG4 LFP battery communication protocol
CAN Protocol	CAN Protocol	Select the protocol according to the communication interface of the battery.	<ol style="list-style-type: none"> 1. P01-LUX Luxpowertek battery CAN protocol V06
Charging Time	The charging time can be set (0-180 minutes)	This parameter is used only when a generator is supplying AC power to the charger.	<p>If charging time is set to 30 minutes, and the charging time is reached (if the SOC Stop or Voltage Stop does not reach the end value at this time), the charging will complete, and the generator will shut down. (Clarification: When the charger is charging, the charging time starts counting.)</p> <p>NOTE: The charging time is set to "0", it will disable this function and the charging time is invalid</p>



NOTE:

1. SOC START should always be less than SOC STOP. VOLTAGE START should always be less than VOLTAGE STOP.
2. Open loop (BMS without communication), Voltage Stop should always be less than Charging Voltage.
3. The charging time is set to "0", it will disable this function, and the charging time is invalid.

LCD SETTINGS

The following section provides detailed instructions for configuring the EG4® Chargeverter Plus parameter settings using the LCD interface.



NOTE:

When configuring the EG4 Chargeverter Plus to charge by voltage, verify there is at least a 5V difference between Voltage Start and Voltage Stop. The images below are for representation purposes only.

- Hold "ENTER" for 2 seconds to display the "Generator Settings" screen shown to the right. The "Voltage" setting will be highlighted. Press the "UP/DOWN" buttons to scroll left/right through the various parameters.

Next Page	Charging	
Generator Settings [1]		
Voltage	SOC Start	Voltage Start
57.0V	80%	43.0V
Current	SOC Stop	Voltage Stop
10.0A	100%	55.0V

- To modify a parameter, scroll to the desired parameter (in this case, Voltage as shown to the right). Press the “ENTER” button to select the voltage in the highlighted area. Press the “UP” button or “DOWN” button to make changes to this value. Press “ENTER” to accept the changes or “ESC” to ignore them.

Next Page	Charging	
Generator Settings [1]		
Voltage	SOC Start	Voltage Start
56.1V	80%	43.0V
Current	SOC Stop	Voltage Stop
10.0A	100%	55.0V

- Press the “DOWN” button to highlight the “SOC Start” setting.

Next Page	Charging	
Generator Settings [1]		
Voltage	SOC Start	Voltage Start
56.1V	80%	43.0V
Current	SOC Stop	Voltage Stop
10.0A	100%	55.0V

- Press the “ENTER” button to select the SOC Start parameter in the highlighted area. Press the “UP” button or “DOWN” button to make changes to this value. Press “ENTER” to accept the changes or “ESC” to ignore them.

Next Page	Charging	
Generator Settings [1]		
Voltage	SOC Start	Voltage Start
56.1V	83%	43.0V
Current	SOC Stop	Voltage Stop
10.0A	100%	55.0V

- Press the “DOWN” button to highlight the Voltage Start setting and repeat the steps above to make and save changes to the Voltage Start parameter.

Next Page	Charging	
Generator Settings [1]		
Voltage	SOC Start	Voltage Start
56.1V	83%	43.0V
Current	SOC Stop	Voltage Stop
10.0A	100%	55.0V

- Repeat the steps above to make and save the changes to the Current, SOC Stop, and Voltage Stop parameters, as needed.



NOTE:

Verify there is at least a 5V difference between Voltage Start and Voltage Stop.

Next Page	Charging	
Generator Settings [1]		
Voltage	SOC Start	Voltage Start
56.1V	83%	43.0V
Current	SOC Stop	Voltage Stop
10.0A	100%	55.0V

- Press the “ENTER” button to go to the next page of parameters (Preheat Time and Cooling Time).



NOTE:

Select “Next Page” to proceed to Generator Settings 2 and 3.

Next Page	Charging	
Generator Settings [1]		
Voltage	SOC Start	Voltage Start
56.1V	83%	43.0V
Current	SOC Stop	Voltage Stop
10.0A	100%	55.0V

- Repeat the steps above to navigate to, adjust, and save changes to the Preheat Time, Cooling Time, RS485 Protocol, and CAN Protocol parameters, as needed.

Next Page	Charging	
Generator Settings [2]		
Preheat Time	Cooling Time	
1.0M	1.0M	
RS485 Protocol	CAN Protocol	
P01-GRW	P01-LUX	

- Repeat the steps above to make and save changes to the Charging Time.

Next Page	Charging	
Generator Settings [3]		
Charging Time		
30M		



NOTE:

Preheat Time: The preheating time can be set to 0 – 5 minutes. After starting the generator, the charger will not charge the battery during the preheating time.

Cooling Time: The cooling time can be set to 0 – 5 minutes. After the battery is charged, the generator will not be started during the cooling time.

7.3 CHARGER COMMUNICATIONS

The EG4® Chargeverter Plus includes the option to connect the charger to a properly equipped battery for communications through the CAN/RS485 communication cable. The charger will communicate with the battery to get the SOC/Voltage status and use that information to start and stop generator charging at the preset thresholds. These thresholds are adjustable via the LCD. If there is no communication between the charger and battery, the battery voltage is used to start and stop generator charging at preset voltage thresholds (Voltage Start and Voltage Stop). These voltage thresholds are also adjustable via the LCD.

The following table and diagram show the connections necessary to facilitate charger-to-battery communications using the RS485 communication cable provided with the charger. The EG4 LL-S battery series is used in this example for convenience. Connect the CAN/RS485 cable between the RJ45 jack on the right side of the charger (labeled RS485) and the RJ45 jack on the battery (labeled CAN).

RS485 JACK PIN OUT	
RJ-45 PIN	DESCRIPTION
1	BAT-RS485B
2	BAT-RS485A
3	PSU_CANH
4	BAT-CANH
5	BAT-CANL
6	PSU_CANL
7,8	NC=No Connection

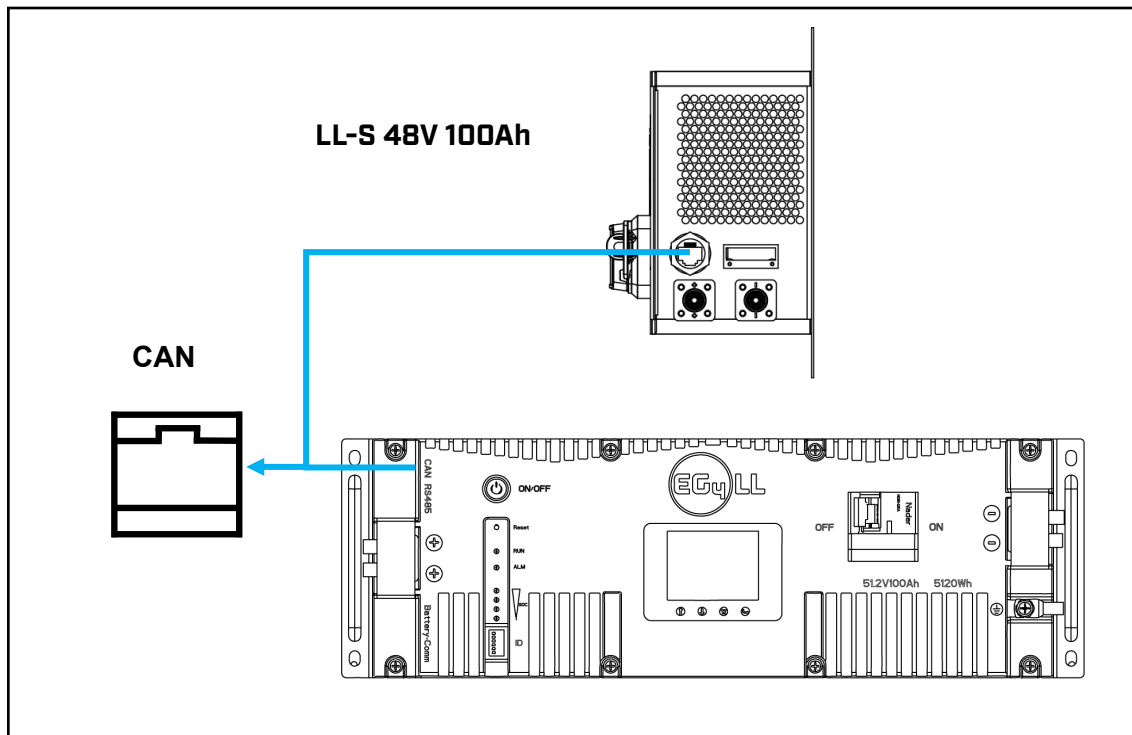

The images below show where the EG4® Chargeverter Plus connects to the LifePower4 V2 48V, WallMount All Weather 280Ah 48V, WallMount Indoor 280Ah 48V, WallMount All Weather 314Ah, and WallMount Indoor 314Ah CAN port.

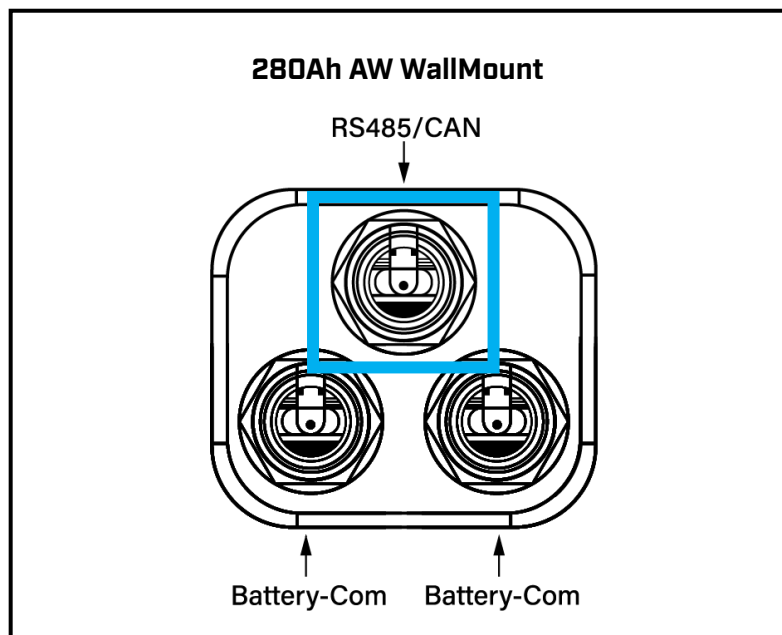
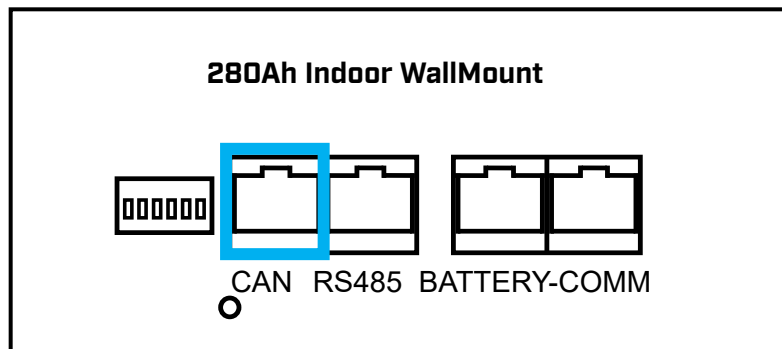
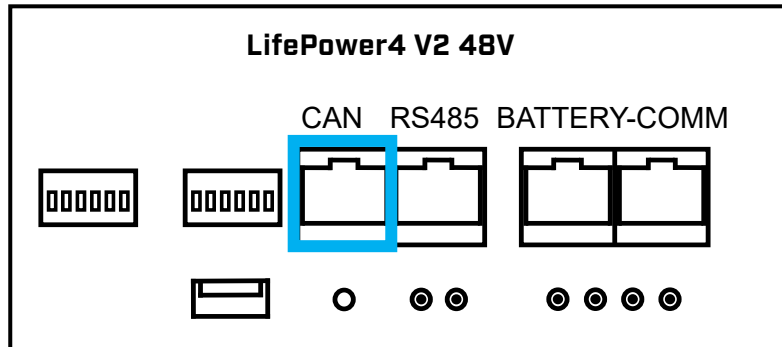

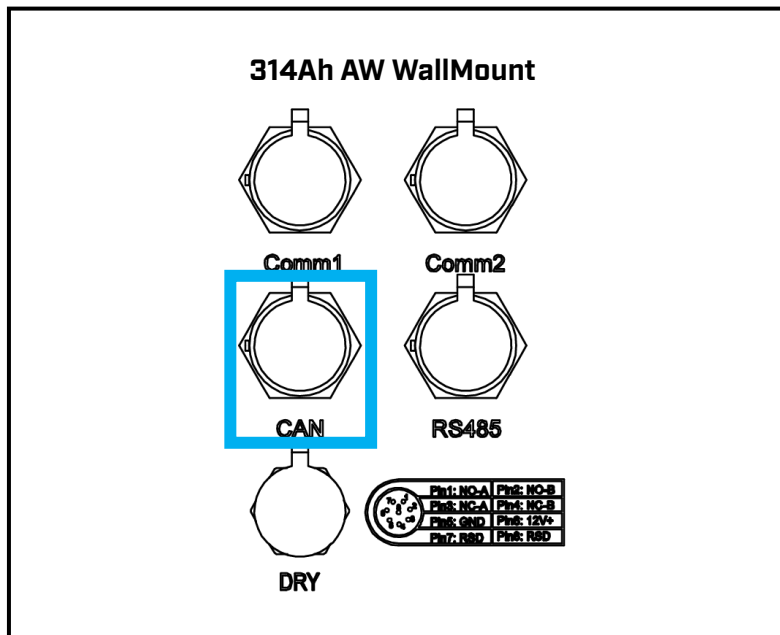
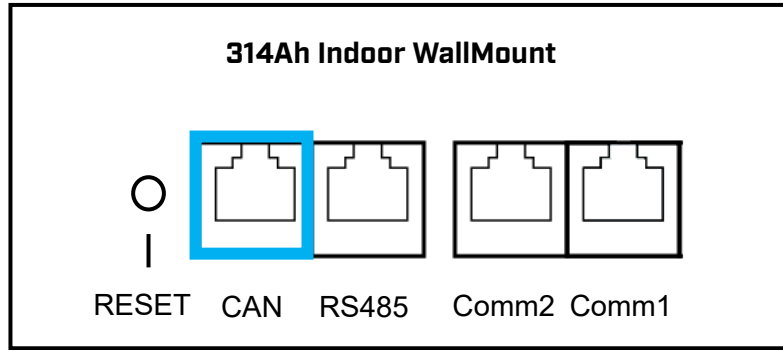

7.4 WORKING WITH A GENERATOR

The EG4® Chargeverter Plus dry contacts are specifically designed to interface with a generator. The charger AC input is simply plugged into the 240 VAC output generator, and the dry contacts are used to start/stop the generator based on user defined thresholds of battery SOC or voltage. During this mode of operation, the charger is powered from the battery's DC voltage.

The following diagram shows the necessary connections to use the generator and the charger to charge the batteries. When the battery SOC or voltage (*) reaches the user defined 'ON' threshold (SOC Start and Voltage Start, respectively), the Normally Open (NO) dry contacts will close, signaling the generator to turn ON. Once the battery SOC or voltage reaches the user defined 'OFF' threshold (SOC Stop and Voltage Stop, respectively) the Normally Open (NO) dry contacts will open, signaling the generator to turn OFF.



NOTE:

If charger-to-battery communications are being used, SOC will be used as the charging ON/OFF thresholds (SOC Start and SOC Stop, respectively). If charger-to-battery communications are not being used, voltage will be used as the charging ON/OFF thresholds (Voltage Start and Voltage Stop, respectively).

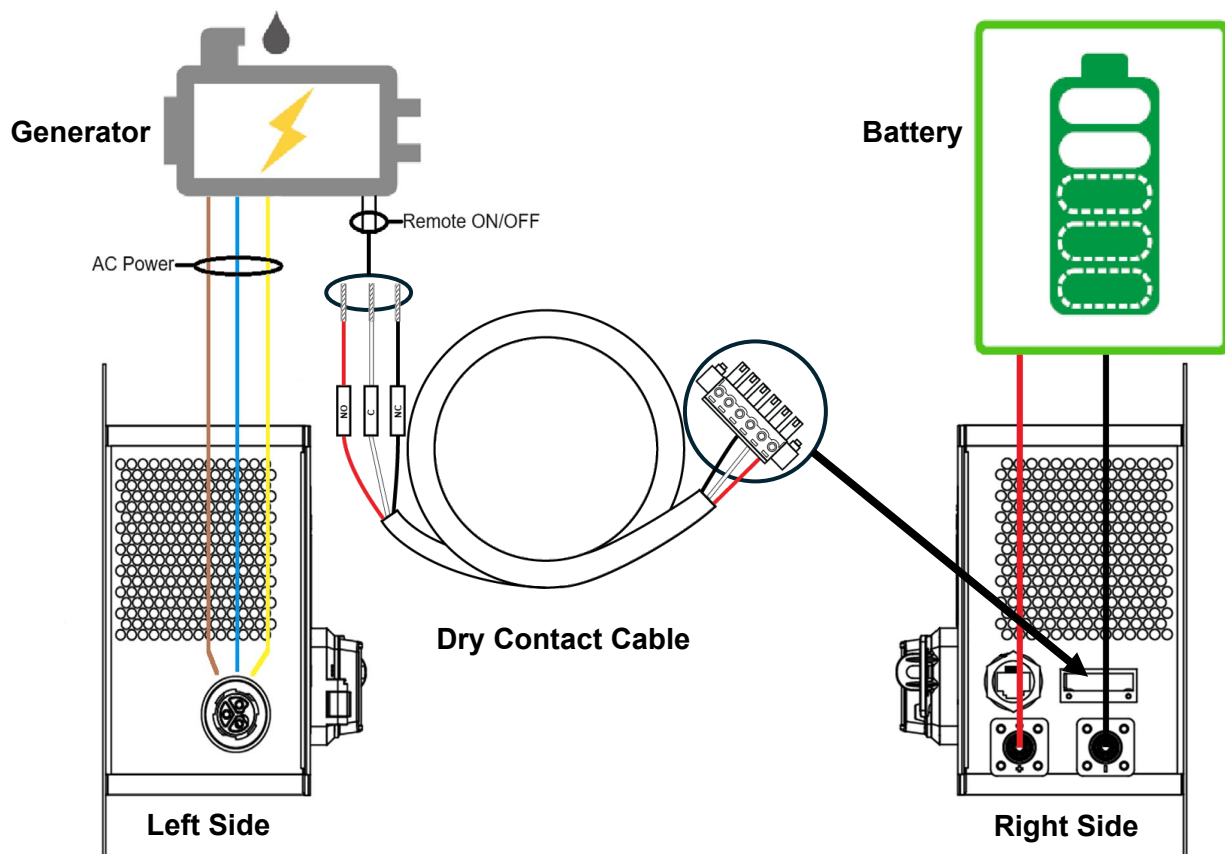

7.5 DRY CONTACT DESCRIPTION

There are dry contacts available on the right side of the EG4® Chargeverter Plus to control a generator. The dry contacts contain 6 pins used in pairs to provide a Normally Open (NO) signal, a Common (C), and a Normally Closed (NC) signal. The jack and plug pin locations are identified in the images below and the wiring and pinout details for the dry contact cable included with the charger are identified in the table below.

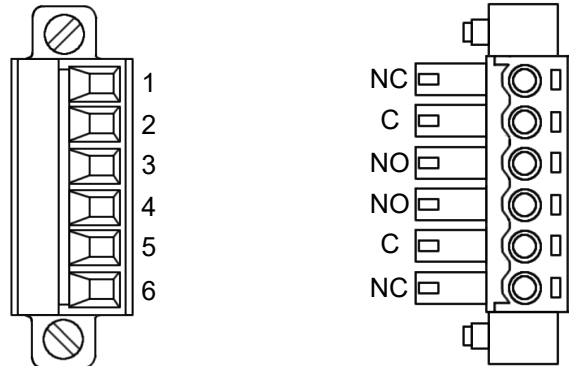

DRY CONTACT PORT PINOUT						
Pair	Pair One			Pair Two		
PIN #	1	2	3	4	5	6
Signal	NC	C	NO	NO	C	NC

These signals can be used to control a generator based on user defined thresholds of battery SOC or voltage. If the charger has communication with the battery, SOC is the priority and is available for charging start/stop thresholds. If there is no communication between the charger and battery, SOC readings are not available, and voltage is used as the charging start/stop threshold. See Section 7.3 for more information on dry contact use for generator control.

UNIT STATUS*	BATTERY CONDITION	DRY CONTACT PORT	
		NO & C**	NC & C**
Power OFF	Unit is OFF	Open	Closed
Power ON Charger to Battery Comms NOT used (No SOC)	Battery Voltage < Voltage Start	Closed (Generator ON)	Open
	Battery Voltage > Voltage Stop	Open (Generator OFF)	Closed
	Voltage Start < Battery Voltage < Voltage Stop	Closed while charging (Generator ON) Open while discharging (Generator OFF)	Open while charging Closed while discharging

*Power provided to unit with AC power (120, 208, or 240 VAC) or DC power from batteries (~48 VDC)

**NC = Normally Closed, NO = Normally Open, C = Common

The following table shows the Generator ON/OFF status based on the user defined thresholds and the Normally Open (NO) dry contacts on the Chargeverter Plus. SOC is used if charger to battery communications are being used. Voltage is used if SOC is not available.

BATTERY CONDITION	NO CONTACT [REFERENCE TO COMMON]	GENERATOR STATUS
Battery SOC < SOC Start	Closed	ON
Battery SOC > SOC Stop	Open	OFF
SOC Start < Battery SOC < SOC Stop	Closed while charging Open while discharging	ON while charging OFF while discharging
Battery Voltage < Voltage Start	Closed	ON
Battery Voltage > Voltage Stop	Open	OFF
Voltage Start < Battery Voltage < Voltage Stop	Closed while charging Open while discharging	ON while charging OFF while discharging

BATTERY WORKING STATUS	NO CONTACT [REFERENCE TO COMMON]	GENERATOR STATUS
0: Standby Mode	Open	OFF
1: Preheating State of Generator	Closed	ON
2: Battery Charging State	Closed	ON
3: Cooling State of Generator	Open	OFF
4: Discharge State	Open	OFF
5: PSU Fault State	Open	OFF

8. TROUBLESHOOTING AND MAINTENANCE

8.1 TROUBLESHOOTING

When the EG4® Chargeverter Plus has troubleshooting or fault, there will be no alarms or sound. It will appear on the main display letting the end-user know what the issue is.

The table below shows the issues and how to troubleshoot them:

ISSUES AND SOLUTIONS:

ISSUE	ACTION
No power from AC	<ol style="list-style-type: none"> 1. Verify the breaker to the outlet the Chargeverter is connected to. 2. Verify that all connections are secure and tight. 3. Verify that the power cord is in good condition and properly secured.
No power from DC	Verify that the battery cables have not been crossed.
No communication to battery	<ol style="list-style-type: none"> 1. Verify that the cable is plugged into the CAN port. 2. Verify cable has the correct pinout (see section 7.5).
No Amperage	<ol style="list-style-type: none"> 1. Verify that the breaker on the Chargeverter Plus is in the “OPEN” position. 2. Check settings. Verify that the SOC Start and Stop are correct. 3. SOC Start is more than the current battery charge. 4. Refer to “No Communication to Battery” for more actions. If communication with the battery is lost, the system will not utilize the State of Charge (SoC) settings and may either fail to start or attempt to operate using open-loop voltage settings.
No Voltage	<ol style="list-style-type: none"> 1. Check settings. Verify that the SOC Start and Stop are correct. 2. SOC Start is more than the current battery charge. 3. Verify the power cable are secured properly and the battery breaker is in the OPEN position. <p>Note: If set up correctly, resting voltage will be seen even if the charger isn’t charging.</p>
Dry Contact Communication	Verify that the pinouts to the cable are correct – (see section 7.5).



NOTE:

If any of the warnings or faults from both tables persist, please contact the distributor for additional troubleshooting steps.

9. MAINTENANCE

EG4® Chargeverter Plus must be properly maintained to increase longevity and consistency. Follow the steps below to help prevent component damage/deterioration.

ITEM	MAINTENANCE INTERVAL	MAINTENANCE SOLUTION
Generator	Every month	Inspect the generator every month and verify that it is tuned up, cables are not loose, and parameters are set correct. Note: If using a generator, verify it is maintained per the manufacturer's manual and standards before inspection.
Chargeverter Plus	Every 1-3 months	Inspect the Chargeverter Plus every month to confirm that dust is not covering the filter on the fan vents. If there is, shut down the chargeverter and clear the dust. Note: See section 9.1 on how to clean the filter.
	Every 3 months	Inspect the Chargeverter Plus every 3 months to verify the operating parameters are normal, and there is no abnormal heating or noise from any components in the system.
	Every 6 months	Inspect the Chargeverter Plus every 6 months to check for any damaged cables, accessories, or terminals.



NOTE:

If unable to identify the source of any potential abnormal operations, contact the distributor's technical support team for additional information.

9.1 CLEANING THE FILTERS

Follow the steps below to properly clean the filters in the Chargeverter Plus.

1. Remove the four screws from the left side vent to expose the filter and set these screws and vent to the side.
2. Remove the filter and clean it using warm water and mild soap. Verify the filter is completely dry before reinstalling.
3. Once dry, reinstall the filter and place the vent cover back on using the four screws from step 1.
4. Repeat all steps for the right side vent.

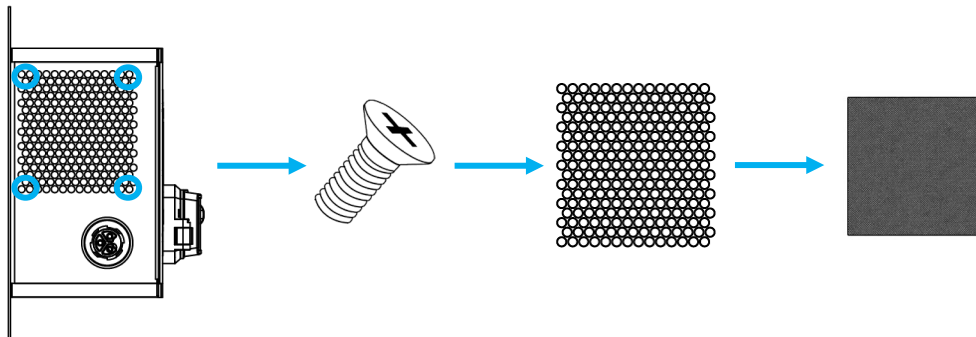

10. WARRANTY INFORMATION

For information regarding warranty registration on EG4® Electronics products, please navigate to <https://eg4electronics.com/warranty/> and select the corresponding product to begin the registration process.

11. STORAGE

Please follow these instructions for the safe storage of the unit to maintain the longevity of the Chargeverter Plus, if choosing not to install the product immediately after purchasing or unpacking the box.

There are a few steps that can be taken to ensure that the Chargeverter Plus are stored safely and in a state that will ensure they are not damaged during storage. The steps are detailed below.

11.1 ENVIRONMENTAL FACTORS

The environment the Chargeverter Plus is stored in can greatly affect the health of the Chargeverter Plus. **For best results**, the temperature should range between -40°F and 158°F (-40°C and 70°C). Mount the Chargeverter Plus in a location where it is not exposed to direct rain, standing water and ***ensure the Chargeverter Plus is mounted on non-combustible material.*** – ***Keep the Chargeverter Plus away from direct sunlight.***

12. CHANGELOG

v1.0.1

- Added cleaning the filters to maintenance section
- Added Chargeverter Power Cord-120V compatibility
- Added images of connections from WallMount 314Ah Indoor and All Weather batteries to Chargeverter Plus
- Added images of Comms connections for WallMount 314Ah Indoor and All Weather
- Added verbiage of Chargeverter Power Cord-120V to section 6.3
- Minor formatting corrections and typos
- Added Troubleshooting and Maintenance section

v1.0

- Published v1.0

EG4

ELECTRONICS

support@eg4electronics.com
(903) 609-1988
www.eg4electronics.com