

EG4[®] 18kPV HYBRID INVERTER

USER MANUAL



TABLE OF CONTENTS

1.	TECHNICAL SPECIFICATIONS.....	1
2.	ABBREVIATION LIST.....	4
3.	INVERTER SAFETY.....	5
3.1	SAFETY INSTRUCTIONS.....	5
3.2	IMPORTANT SAFETY NOTIFICATIONS.....	5
4.	SÉCURITÉ DE L'ONDULEUR.....	7
4.1	INSTRUCTIONS DE SÉCURITÉ.....	7
4.2	NOTIFICATIONS DE SÉCURITÉ IMPORTANTES.....	7
5.	SYSTEM DIAGRAMS.....	9
6.	INSTALLATION.....	10
6.1	PACKING LIST.....	10
6.2	TOOLS NEEDED FOR INSTALLATION.....	10
6.3	LOCATION SELECTION AND INSTALLATION.....	11
7.	CONNECTION OVERVIEW.....	15
7.1	PV CONNECTION.....	18
7.2	BATTERY CONNECTIONS.....	21
7.3	AC CONNECTIONS.....	24
7.4	GENERATOR CONNECTIONS.....	27
7.5	OFF-GRID WIRING.....	28
7.6	AC COUPLING INSTALLATION CONNECTION.....	28
7.7	PARALLEL SYSTEM CONNECTION.....	29
7.8	GRID, LOAD, AND AC CONNECTION.....	31
7.9	GRID AND LOAD CONNECTIONS FOR SPLIT-PHASE SERVICE.....	32
7.10	WIRING DIAGRAMS.....	32
8.	MONITOR SYSTEM SETUP.....	42
8.1	WI-FI/4G DONGLE CONNECTION.....	42
8.2	CONNECTIVITY REQUIREMENTS.....	42
8.3	ONLINE MONITORING SYSTEM USER INTERFACE.....	43
8.4	SMARTPHONE APP SETUP.....	44
8.5	ENABLE APP NOTIFICATIONS.....	46
8.6	LOCAL MONITORING SETUP WITH THE EG4® MONITOR APP.....	48
9.	OPERATION GUIDE.....	48
9.1	INVERTER START-UP AND SHUTDOWN PROCEDURE.....	48
9.2	LCD SCREEN.....	49
9.3	WORKING MODES AND RELATED SETTINGS.....	55
9.4	RAPID SHUTDOWN (RSD).....	63
10.	POWER CONTROL SYSTEM.....	65
10.1	EXPORT LIMITING FROM ALL SOURCES (PEL).....	65
10.2	ESS MODE.....	67
11.	FIRMWARE UPDATES.....	69
11.1	FIRMWARE UPDATE VIA EG4® ELECTRONICS APP.....	69
11.2	FIRMWARE UPDATE VIA MONITOR CENTER.....	70
12.	TROUBLESHOOTING AND MAINTENANCE.....	70
12.1	TROUBLESHOOTING WI-FI MODULE.....	70
12.2	REGULAR MAINTENANCE.....	71
12.3	LED DESCRIPTION.....	71
12.4	TROUBLESHOOTING BASED ON LCD SCREEN.....	72
13.	CHANGELOG.....	76

1. TECHNICAL SPECIFICATIONS

AC INPUT DATA	
NOMINAL AC VOLTAGE	120/240VAC; 120/208VAC (L1/L2/N required)
FREQUENCY	50/60Hz
MAX. AC CURRENT	50A @ 240VAC
MAX. AC INPUT POWER	12000W
MAX. AC BYPASS	200A
AC GRID OUTPUT DATA	
MAX. OUTPUT CURRENT	50A
OUTPUT VOLTAGE	120/240VAC; 120/208VAC (L1/L2/N required)
OPERATING VOLTAGE RANGE	180-270VAC
NOMINAL POWER OUTPUT	@240V 12000W @208V 10400W
FREQUENCY	50/60Hz
POWER FACTOR	0.99 @ Full Load
REACTIVE POWER ADJUST RANGE	(-0.8) ≈ (+0.8) Leading Adjustable
MAX CONT. LINE WATTAGE	6000W
PEAK POWER (SURGE CAPACITY)	w/ PV: 14700W (10 min), 15500W (5 min) w/o PV: 13500W (10 min)
THD @FULL LOAD	<5%
OPEN LOOP RESPONSE TIME (OLRT)	<2 seconds
TIME TO STEADY STATE	<10 seconds
TRANSFER TIME	20ms (Default), 10ms (Configurable) Parallel – 20ms
BACKUP/UPS AC OUTPUT DATA	
RATED OUTPUT CURRENT (240/208VAC)	50A
AC BYPASS (GENERATOR)	90A
NOMINAL OUTPUT VOLTAGE	240 120/240 120/208VAC
RATED OUTPUT POWER	@240VAC 12000W @208VAC 10400W
MAX. CONTINUOUS LINE WATTAGE	8000W per 120V
PEAK POWER	w/ PV: 14700W (10 min), 15500W (5 min) w/o PV: 13500W (10 min)
THDV (TOTAL HARMONIC DISTORTION VOLTAGE)	<5%
OPEN LOOP RESPONSE TIME (OLRT)	<2 seconds
TIME TO STEADY STATE	<10 seconds
SWITCHING TIME	10ms

PV INPUT DATA	
NUMBER OF MPPTS	3
INPUTS PER MPPT	2 (MPPT 1) 1 (MPPT 2) 1 (MPPT 3)
MAX. USABLE INPUT CURRENT	25A (MPPT 1) 15A (MPPT 2) 15A (MPPT 3)
MAX. SHORT CIRCUIT INPUT CURRENT	31A (MPPT 1) 19A (MPPT 2) 19A (MPPT 3)
DC INPUT VOLTAGE RANGE	100-600 VDC*
UNIT STARTUP VOLTAGE	100 VDC
MPPT OPERATING VOLTAGE RANGE	140-500 VDC**
NOMINAL MPPT VOLTAGE	360 VDC
MPPT VOLTAGE HIGH PROTECTION	550 VDC***
MAXIMUM UTILIZED SOLAR POWER	18000W
RECOMMENDED MAXIMUM SOLAR INPUT	21000W
EFFICIENCY	
CEC	96.9%
MAXIMUM EFFICIENCY (PV TO GRID)	97.5%
MAXIMUM EFFICIENCY (BATTERY TO GRID)	94%
MAXIMUM EFFICIENCY (PV TO BATTERY)	99.9%
IDLE CONSUMPTION (NORMAL STANDBY MODE)	~70W ~18W
BATTERY DATA	
COMPATIBLE BATTERY TYPES	Lead-acid/Lithium
MAX. CHARGE/DISCHARGE CURRENT	250A
NOMINAL VOLTAGE	48 VDC
VOLTAGE RANGE	40-60 VDC (Lithium); 40-60 VDC (Lead-acid)
RECOMMENDED BATTERY CAPACITY PER INVERTER	≥300Ah

*Do not exceed the high end of the DC Input Voltage Range. Any damage caused by reaching >600 VDC will not be covered under warranty.

When sizing the system, it is best practice to follow the nominal MPPT voltage specifications and not the minimum/maximum voltage of the MPPT operating voltage range. **Only qualified personnel need to perform these calculations.

***The value at which the inverter will fault to protect the MPPT from the overvoltage spec of 600VDC (PV Volt High). Ensure **geographical considerations, weather patterns, and panel specifications** are factored into string sizing.

See <https://eg4electronics.com/wp-content/themes/hello-elementor/eg4-solar-panel-string-sizer/> for the EG4® string sizing tool.

GENERAL DATA	
MAX. UNITS IN PARALLEL	10
PRODUCT DIMENSIONS (H×W×D)	34.3×20.5×11.2 in (870×520×285mm)
UNIT WEIGHT	121 lbs. (55kg)
DESIGN TOPOLOGY	High Frequency - Transformerless
RELATIVE HUMIDITY	0-100%
OPERATING ALTITUDE	<2000m (<6561ft)*
OPERATING AMBIENT TEMPERATURE RANGE	-13°F – 140°F (-25°C – 60°C)
STORAGE AMBIENT TEMPERATURE RANGE	-13°F – 140°F (-25°C – 60°C)
NOISE EMISSION (TYPICAL)	68dB @ 3ft
LOCKED ROTOR AMPS (LRA)	180A
COMMUNICATION INTERFACE	RS485/Wi-Fi/CAN
STANDARD WARRANTY	10-year standard warranty**
OUTDOOR RATING	NEMA 4X
SAFETY FEATURES	PV Arc Fault Protection, PV Ground Fault Protection, PV Reverse Polarity Protection, Pole Sensitive Leakage Current Monitoring Unit, Surge Protection Device, Integrated PV Disconnect

STANDARDS AND CERTIFICATIONS	
UL1741, SA, SB, PCS CRD	
RAPID SHUT DOWN (RSD) NEC 2020:690.12	
ARC-FAULT CIRCUIT INTERRUPTER (AFCI) NEC 2020:690.11 / UL1699B	
GROUND FAULT MONITORING (GFDI) NEC 2020:690.41(B)	
CSA 22.2.107.1	
CSA 22.2.330	
IEEE 1547.1:2020; IEEE 1547:2018	
HAWAII RULE 14H	
CALIFORNIA RULE 21 PHASE I, II, III	
FCC PART 15, CLASS B	

*For installations above 2000 m, the inverter needs to be derated to specific values depending on the elevation. Refer to the "Inverter Altitude and Derating Usage Restrictions" guide by navigating to <https://eg4electronics.com/wp-content/uploads/2026/04/EG4-Inverter-Altitude-Derating-Usage-Restrictions.pdf> or by scanning the QR code below.

**For information regarding warranty registration on EG4® Electronics products, please navigate to <https://eg4electronics.com/warranty/> and select the corresponding product to begin the registration process.



2. ABBREVIATION LIST

- AWG – American Wire Gauge
- A – Amps
- Ah – Amp hour(s)
- AC – Alternating Current
- AFCI – Arc-Fault Circuit Interrupter
- AHJ – Authority Having Jurisdiction
- kAIC – kilo-Amp Interrupting Capability
- ANSI – American National Standards Institute
- BAT – Battery
- BMS – Battery Management System
- COM – Communication
- CT – Current Transformer
- DC – Direct Current
- DIP – Dual In-line Package
- DOD – Depth of Discharge
- EG – Equipment Ground
- EGS – Equipment Grounding System
- EMC – Electromagnetic Compatibility
- EPS – Emergency Power System
- ESS – Energy Storage System
- E-Stop – Emergency Stop
- FCC – Federal Communication Commission
- GE – Grounding Electrode
- GEC – Grounding Electrode Conductor
- GFCI – Ground Fault Circuit Interrupter
- GFDI – Ground Fault Detector/Interrupter
- Imp – Maximum Power Point Current
- IEEE – Institute of Electrical and Electronic Engineers
- IP – Ingress Protection
- I_{sc} – Short-Circuit Current
- In-lbs. – Inch Pounds
- kW – Kilowatt
- kWh – Kilowatt-hour
- LCD – Liquid Crystal Display
- LFP – Lithium Iron Phosphate
- L1 – Line 1
- L2 – Line 2
- mm – Millimeters
- MPPT – Maximum Power Point Tracking
- mV – Millivolt
- N – Neutral
- NEC – National Electric Code
- NEMA – National Electrical Manufacturers Association
- NFPA – National Fire Prevention Association
- Nm – Newton Meters
- NOCT – Normal Operating Cell Temperature
- PC – Personal Computer
- PCB – Printed Circuit Board
- PE – Protective Earth
- PPE – Personal Protective Equipment
- PV – Photovoltaic
- RSD – Rapid Shut Down
- SCC – Standards Council of Canada
- SOC – State of Charge
- STC – Standard Testing Conditions
- UL – Underwriters Laboratories
- UPS – Uninterrupted Power Supply
- V – Volts
- VOC – Open-Circuit Voltage
- VMP – Voltage Maximum Power

3. INVERTER SAFETY

3.1 SAFETY INSTRUCTIONS

International safety regulations have been strictly observed in the design and testing of the inverter. Before beginning any work, carefully read all safety instructions, and always observe them when working on or with the inverter. The installation must follow all applicable national or local standards and regulations.

Incorrect installation may cause:

- Injury or death to the installer, operator or third party
- Damage to the inverter or other attached equipment

3.2 IMPORTANT SAFETY NOTIFICATIONS



DANGER: Hazardous Voltage Circuits!

There are various safety concerns that must be carefully observed before, during, and after the installation, as well as during future operation and maintenance. The following are important safety notifications for the installer and any end users of this product under normal operating conditions.

1. **Beware of high PV voltage.** Install an external DC disconnect switch or breaker and ensure it is in the “off” or “open” position before installing or working on the inverter. Use a voltmeter to confirm there is no DC voltage present to avoid electric shock.
2. **Beware of high grid voltage.** Ensure the AC switch and/or AC breaker are in the “off” or “open” position before installing or working on the inverter. Use a voltmeter to confirm there is no voltage present to avoid electric shock.
3. **Beware of high battery current.** Ensure that the battery module breakers and/or on/off switches are in the “open” or “off” position before installing or working on the inverter. Use a voltmeter to confirm there is no DC voltage present to avoid electric shock.
4. **Do not open the inverter while it is operating to avoid electric shock and damage from live voltage and current within the system.**
5. Do not make any connections or disconnections (PV, battery, grid, communication, etc.) while the inverter is operating.
6. An installer should make sure to be well protected by reasonable and professional insulative equipment [e.g., personal protective equipment (PPE)].
7. Before installing, operating, or maintaining the system, it is important to inspect all existing wiring to ensure that it meets the appropriate specifications and conditions for use.
8. Ensure that the PV, battery, and grid connections to the inverter are secure and proper to prevent damage or injuries caused by improper installation.
9. Some components of the system can be very heavy. Be sure to utilize team-lift among other safe lifting techniques throughout the installation.



WARNING: TO REDUCE THE RISK OF INJURY, READ ALL INSTRUCTIONS!

All work on this product (system design, installation, operation, setting, configuration, and maintenance) must be carried out by qualified personnel. To reduce the risk of electric shock, do not perform any servicing other than those specified in the operating instructions unless qualified to do so.

1. Read all instructions before installing. For electrical work, follow all local and national wiring standards, regulations, and these installation instructions.
2. Make sure the inverter is properly grounded. All wiring should be in accordance with the National Electrical Code (NEC), ANSI/NFPA 70.
3. The inverter and system can inter-connect with the utility grid only if the utility provider permits. Consult with the local AHJ (Authority Having Jurisdiction) before installing this product for any additional regulations and requirements for the immediate area.
4. All warning labels and nameplates on the inverter should be clearly visible and must not be removed or covered.
5. The installer should consider the safety of future users when choosing the inverter's correct position and location as specified in this manual.
6. Keep children from touching or misusing the inverter and relevant systems.
7. **Beware!** The inverter and some parts of the system can be hot when in use. Do not touch the inverter's surface or most of the parts when they are operating. During operation, only the LCD and buttons should be touched.



WARNING!

Cancer and Reproductive Harm – See www.P65Warnings.ca.gov for more details.

DISCLAIMER

EG4 reserves the right to make changes to the material herein at any time without notice. Please refer to www.eg4electronics.com for the most updated version of our manuals/spec sheets.

4. SÉCURITÉ DE L'ONDULEUR

4.1 INSTRUCTIONS DE SÉCURITÉ

Les réglementations internationales de sécurité ont été strictement observées lors de la conception et des tests de l'onduleur. Avant de commencer tout travail, lisez attentivement toutes les instructions de sécurité et respectez-les toujours lorsque vous travaillez sur ou avec l'onduleur. L'installation doit suivre toutes les normes et réglementations nationales ou locales applicables. Consultez l'autorité locale compétente et/ou le fournisseur d'électricité pour obtenir les permis et autorisations nécessaires avant l'installation.

Une installation incorrecte peut causer:

- Des blessures ou la mort de l'installateur, de l'opérateur ou d'un tiers
- Des dommages à l'onduleur ou à d'autres équipements connectés

4.2 NOTIFICATIONS DE SÉCURITÉ IMPORTANTES



DANGER: *Circuits à haute tension!*

Il y a divers problèmes de sécurité qui doivent être soigneusement observés avant, pendant et après l'installation, ainsi que pendant l'exploitation et la maintenance futures. Les notifications de sécurité suivantes sont importantes pour l'installateur et tout utilisateur final de ce produit dans des conditions normales de fonctionnement.

1. **Attention à la haute tension PV.** Installez un interrupteur ou disjoncteur externe de déconnexion DC et assurez-vous qu'il est en position "off" ou "ouvert" avant d'installer ou de travailler sur l'onduleur. Utilisez un voltmètre pour confirmer qu'il n'y a pas de tension DC présente afin d'éviter les chocs électriques.
2. **Attention à la haute tension du réseau.** Assurez-vous que l'interrupteur AC et/ou le disjoncteur AC sont en position "off" ou "ouvert" avant d'installer ou de travailler sur l'onduleur. Utilisez un voltmètre pour confirmer qu'il n'y a pas de tension présente afin d'éviter les chocs électriques.
3. **Attention au courant élevé de la batterie.** Assurez-vous que les disjoncteurs des modules de batterie et/ou les interrupteurs on/off sont en position "ouvert" ou "off" avant d'installer ou de travailler sur l'onduleur. Utilisez un voltmètre pour confirmer qu'il n'y a pas de tension DC présente afin d'éviter les chocs électriques.
4. **Ne pas ouvrir l'onduleur pendant qu'il fonctionne pour éviter les chocs électriques et les dommages dus à la tension et au courant en direct dans le système.**
5. Ne pas effectuer de connexions ou de déconnexions (PV, batterie, réseau, communication, etc.) pendant que l'onduleur fonctionne.
6. Un installateur doit s'assurer d'être bien protégé par un équipement isolant raisonnable et professionnel (par exemple, équipement de protection individuelle (EPI)).
7. Avant d'installer, d'exploiter ou de maintenir le système, il est important d'inspecter tous les câblages existants pour s'assurer qu'ils répondent aux spécifications et conditions appropriées pour l'utilisation.
8. Assurez-vous que les connexions PV, batterie et réseau à l'onduleur sont sécurisées et appropriées pour éviter les dommages ou les blessures causés par une installation incorrecte.
9. Certains composants du système peuvent être très lourds. Assurez-vous d'utiliser des techniques de levage en équipe parmi d'autres techniques de levage sûres tout au long de l'installation.



AVERTISSEMENT : POUR RÉDUIRE LE RISQUE DE BLESSURE, LISEZ TOUTES LES INSTRUCTIONS !

Tous les travaux sur ce produit (conception du système, installation, exploitation, réglage, configuration et maintenance) doivent être effectués par du personnel qualifié. Pour réduire le risque de choc électrique, ne réalisez aucun entretien autre que ceux spécifiés dans les instructions de fonctionnement, sauf si vous êtes qualifié pour le faire.

10. Lisez toutes les instructions avant d'installer. Pour les travaux électriques, suivez toutes les normes et réglementations locales et nationales de câblage, ainsi que ces instructions d'installation.
11. Assurez-vous que l'onduleur est correctement mis à la terre. Tous les câblages doivent être conformes au Code National de l'Électricité (NEC), ANSI/NFPA 70.
12. L'onduleur et le système peuvent se connecter au réseau électrique uniquement si le fournisseur d'électricité le permet. Consultez l'autorité locale compétente avant d'installer ce produit pour toute réglementation et exigence supplémentaire pour la zone immédiate.
13. Toutes les étiquettes d'avertissement et les plaques signalétiques sur l'onduleur doivent être clairement visibles et ne doivent pas être retirées ou couvertes.
14. L'installateur doit tenir compte de la sécurité des futurs utilisateurs lors du choix de la position et de l'emplacement corrects de l'onduleur, comme spécifié dans ce manuel.
15. Empêchez les enfants de toucher ou de mal utiliser l'onduleur et les systèmes pertinents.
16. **Attention !** L'onduleur et certaines parties du système peuvent être chauds lorsqu'ils sont utilisés. Ne touchez pas la surface de l'onduleur ou la plupart des pièces lorsqu'elles fonctionnent. Pendant le fonctionnement, seuls l'écran LCD et les boutons doivent être touchés.



AVERTISSEMENT !

Cancer et dommages reproductifs – Voir www.P65Warnings.ca.gov pour plus de détails.

DISCLAIMER

EG4® se réserve le droit de modifier le contenu de ce document à tout moment sans préavis. Veuillez consulter www.eg4electronics.com pour la version la plus récente de nos manuels/fiches techniques.

5. SYSTEM DIAGRAMS

This unit and its associated system are suitable for the following applications:

A. Solar and battery storage system

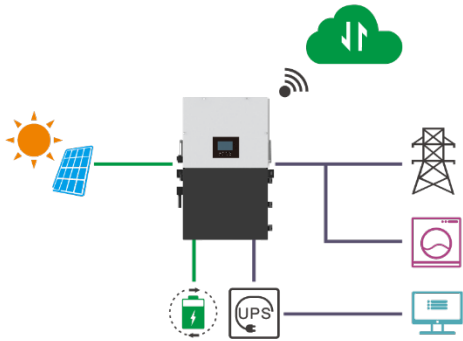

B. AC Coupling with existed solar system

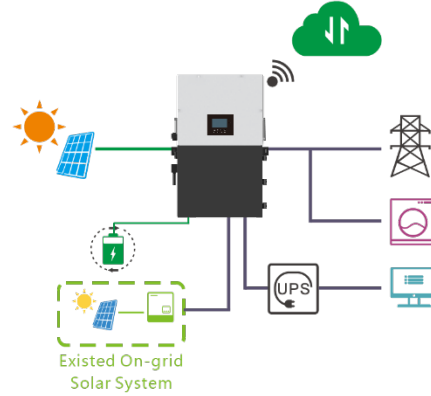

C. On-grid solar system without battery (Support EPS even without battery)

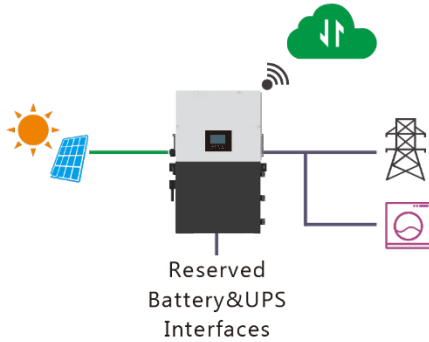

D. Off-grid and back-up applications

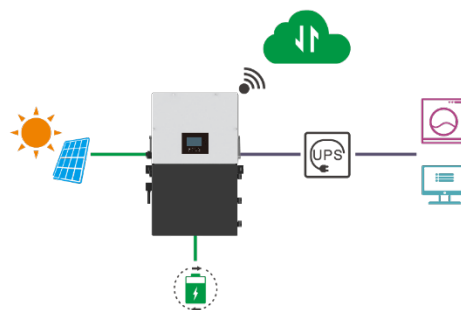

E. Single and three phase paralleling system

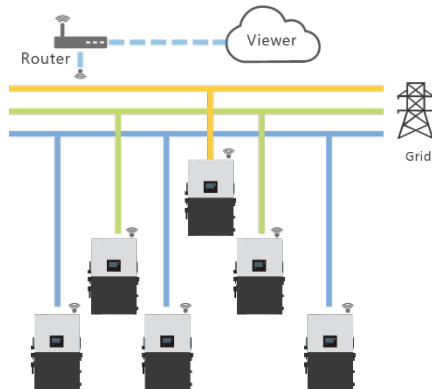

F. Energy storage system with peak shaving Function

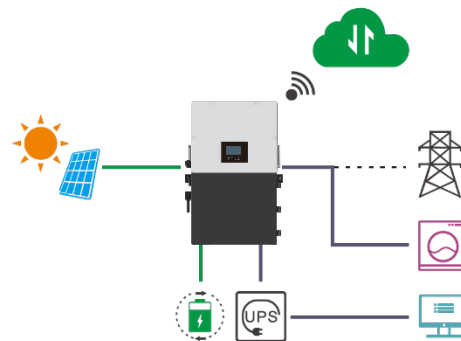

6. INSTALLATION

6.1 PACKING LIST

When the product is unpacked, the contents should match those listed below:
Pictures for reference only.

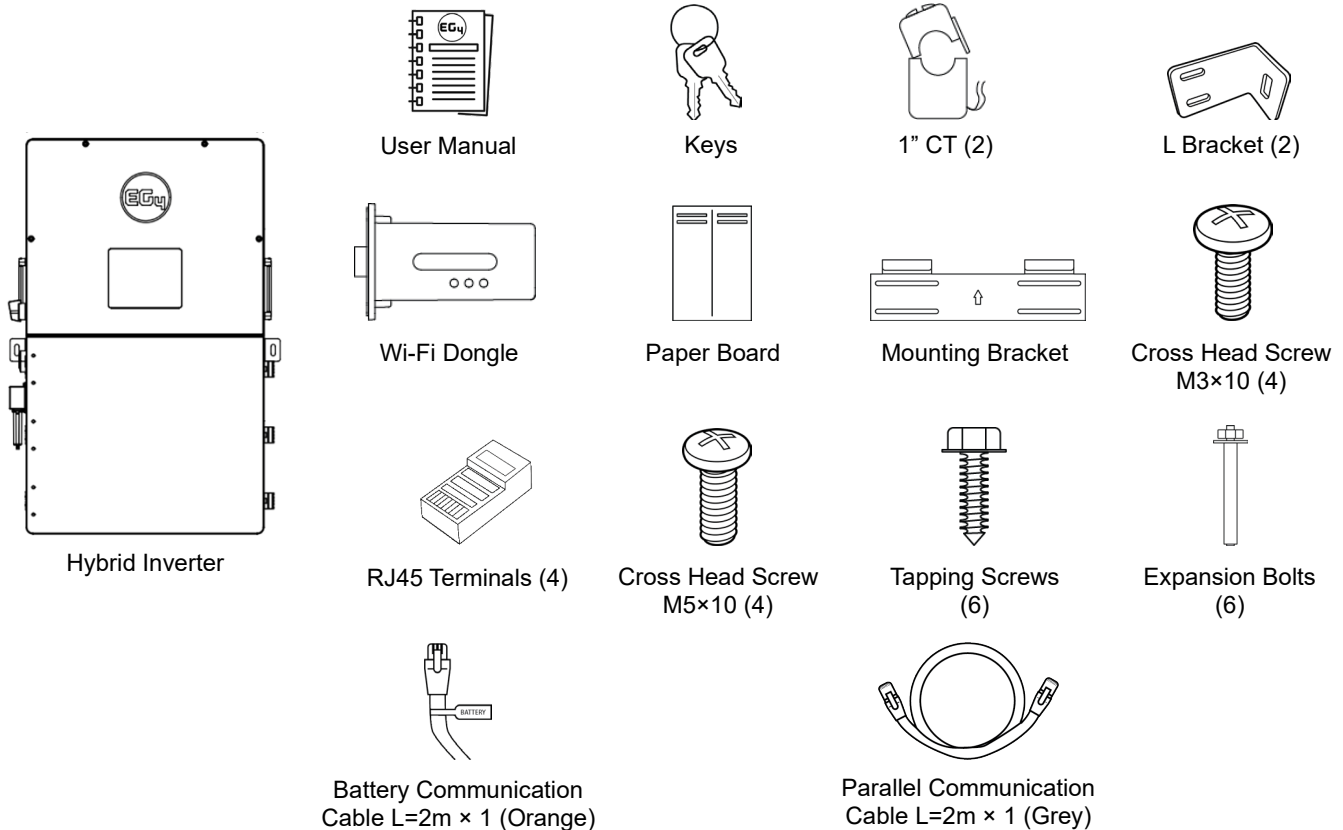

6.2 TOOLS NEEDED FOR INSTALLATION

- Hand truck with all-terrain tires
- Tape measure
- Drill and drill bits (5/16)
- Wire strippers
- Small straight slot
- Lineman's Pliers, rabbit ears or side cutters
- M8 Hex
- M5 Hex
- Multimeter
- Tech screwdriver
- 14 mm or 9/16 socket for anchors
- Medium flat head screwdriver for PV connection
- 13 mm or ½ socket for lag screws
- Level
- Channel Locks
- Self-tapping screws (2)
- Torque wrench
- Heavy duty wood screws (4) – if anchoring in wood OR
- Hammer Drill or masonry bit (9/16)—if anchoring in concrete

6.3 LOCATION SELECTION AND INSTALLATION

Requirements for Installation Location



DANGER:

Ensure there is at least 7.9 inches of space around the inverter for heat to dissipate or else there is a risk of fire. Ensure the inverter is mounted away from all combustible materials.

1. The mounting wall should be strong enough to bear the weight of the inverter.
2. Maintain the minimum clearances presented below for adequate heat dissipation.

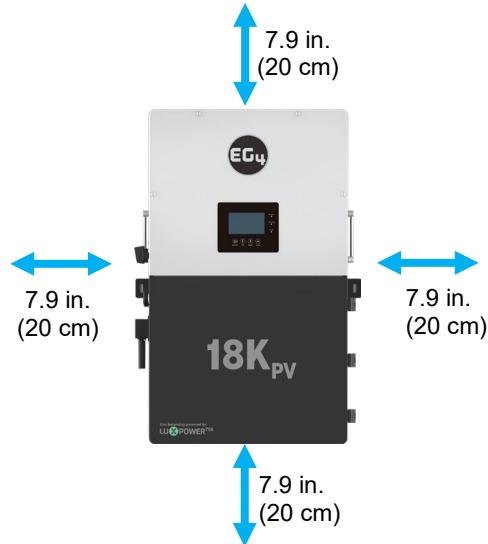

3. Never position the inverter in direct sunlight. Refer to the figure below and choose a well-shaded site or a shed to protect the inverter from direct sunlight. Protect the LCD screen from excessive UV exposure. The inverter should be installed upright on a vertical surface.

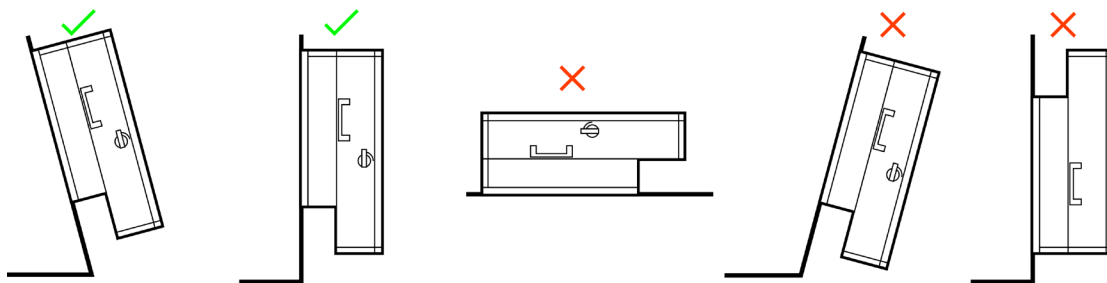

Installing the Inverter

The inverter is designed to be wall-mounted on a vertical, solid **non-combustible** surface such as brick or concrete. Two or more people may be needed to install the inverter due to its weight. The slots on the mounting bracket can accommodate various stud spacings from 12 in. (305 mm) to 16 in. (406 mm).

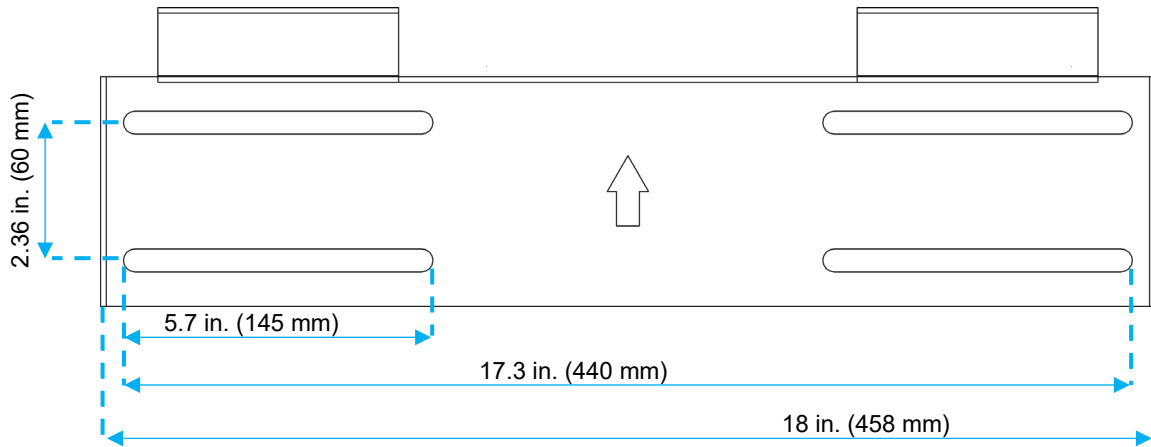

Mounting Steps:

1. Select a location for the inverter's final placement.
2. Use the cardboard template to mark where the mounting bracket screws will be installed.

When installing the bracket to studs, verify the marks for the screws are centered over a stud.

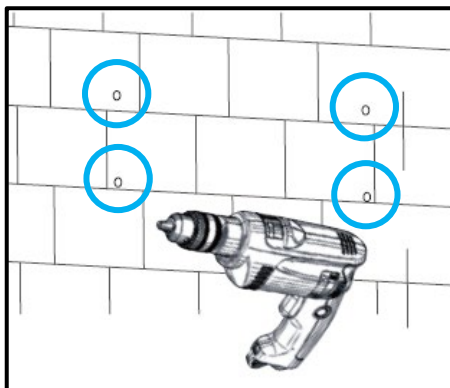
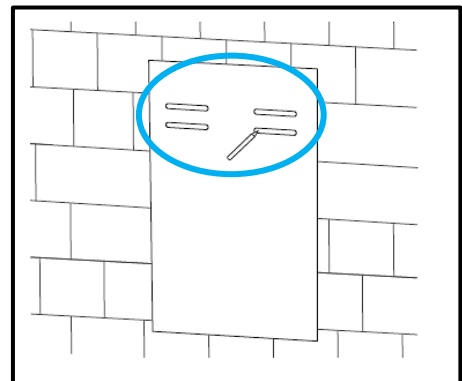

3. When installing the bracket to concrete or brick, drill 5/16 in. (8 mm) diameter holes on the marks, making sure the holes are deeper than 2 in. (50 mm) when using the included expansion bolts. When installing the bracket to studs, drill a pilot hole recommended for the screw diameter used. Ensure the studs are spaced 12 to 16 in. apart.

4. For concrete or brick wall installation, insert the expansion bolts into the drilled holes. Install the bracket to the wall, ensuring the arrow is pointing up. Use the corresponding nuts and washers (packaged together with the expansion bolts) to affix the bracket to the wall. For stud wall installation, use the proper screws and affix the bracket to the wall.

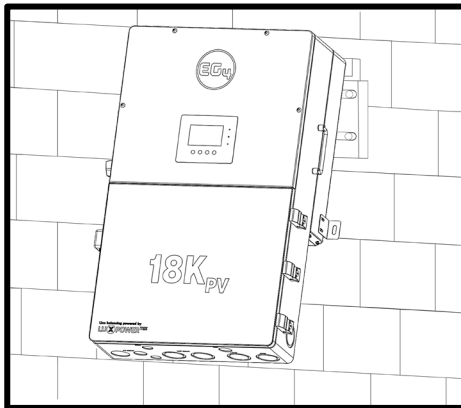
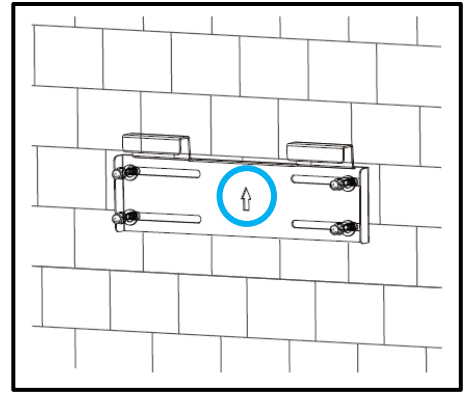

5. Use the team lift technique, place the inverter on to the wall bracket, securing it to the wall.

6. Temporarily mount the L bracket to the side of the inverter (located at the bottom, one on each side). Mark holes on the wall based on the hole location on the right-angled bracket (repeat this step for both sides).

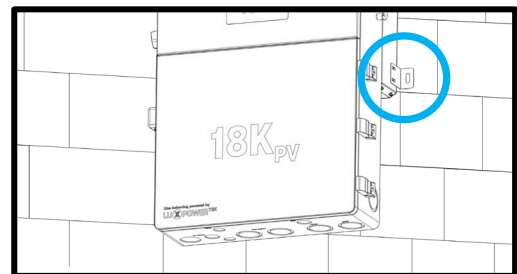

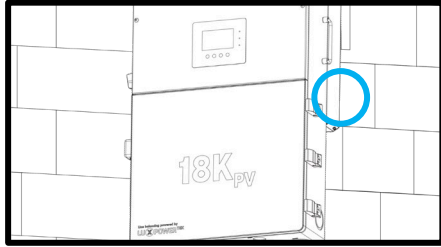

7. Remove the angle bracket and drill a hole at the marking. Use the drill bit size based on the anchor type or screw size as directed in step 3 (repeat this step for both sides).

8. Attach the angle brackets (one on each side) to the inverter and to the wall using the correct hardware. Once the bracket is secure, the wall installation is complete.

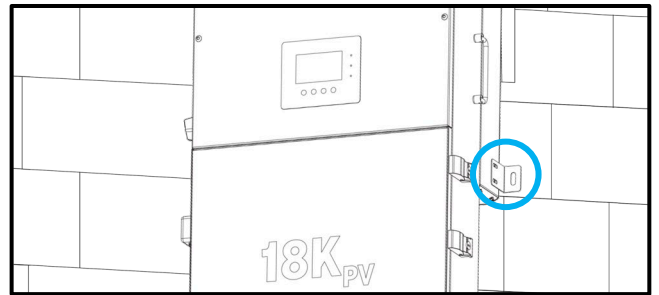

7. CONNECTION OVERVIEW

Breaker selection recommendation for both DC and AC:

Label	Breaker/Switch	Description
A	PV Input	See Section 7.1
B	Integrated Bonded Battery Breaker	200A × 2
C	Integrated Bonded Load Breaker	L1:200A L2:200A
D	AC Input/Output	See Section 7.3
E	Generator	240VAC/100A

Overview of the Cable Box

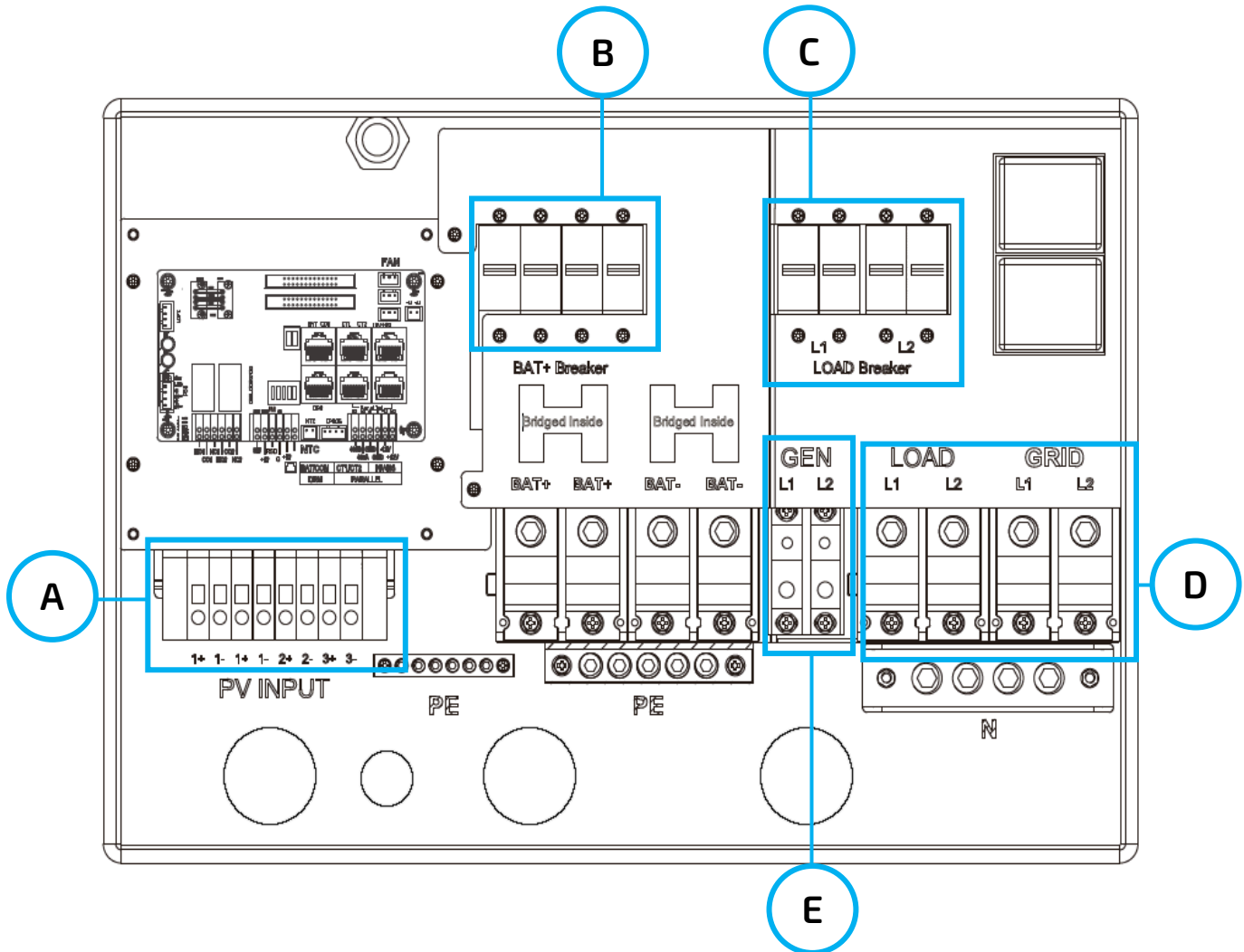

For more information on wiring and connections, see section 7.

Overview of Connection Ports

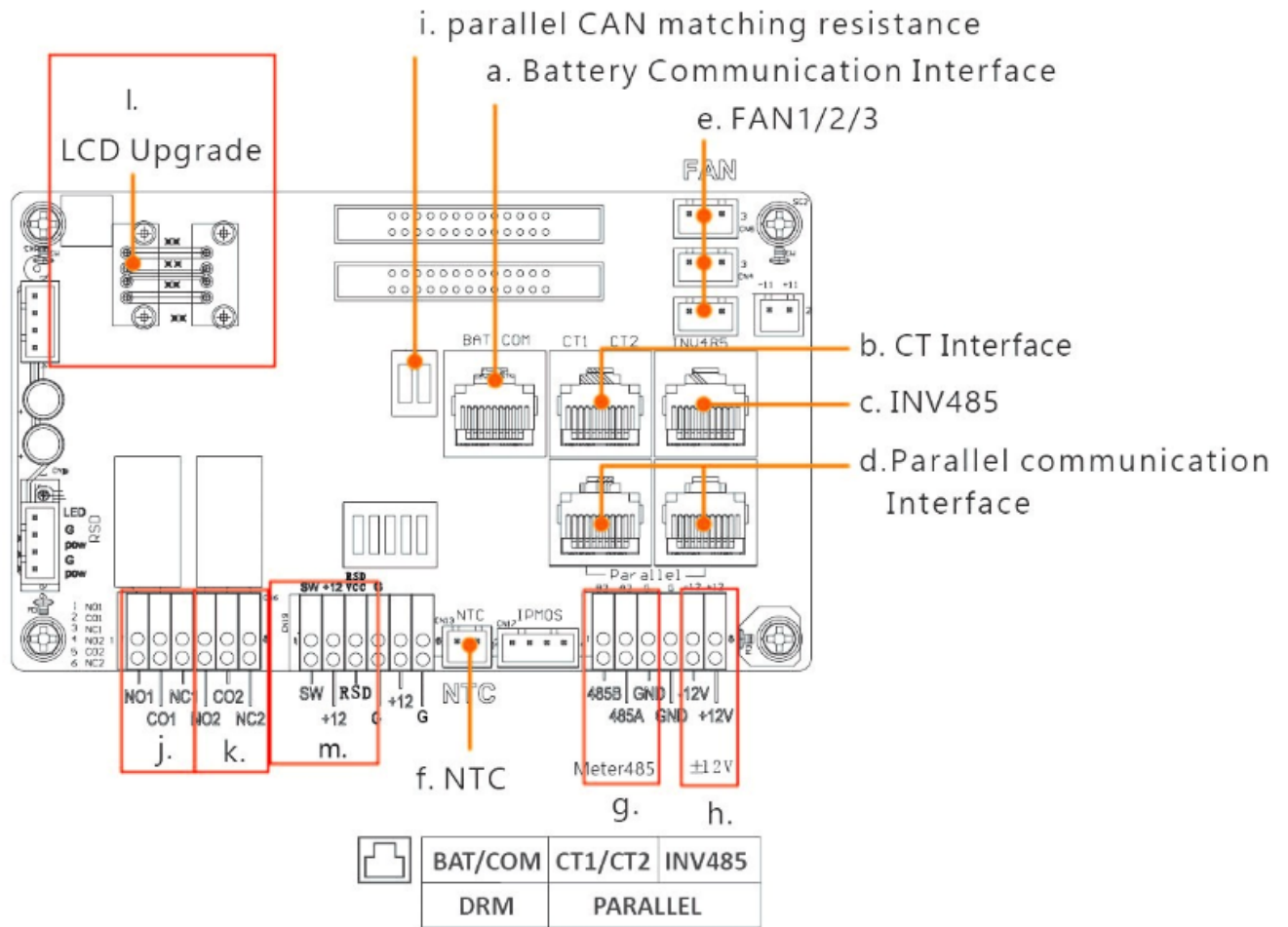

- a. Battery communication port (CAN & RS485)
- b. CT interface (refer to Section 7.3 for CT connection)
- c. INV 485: debugging port
- d. Parallel communication port (refer to Section 6.6 for parallel connection)
- e. Fans 1/2/3
- f. Temp sensor connection for lead-acid battery
- g. Meter 485B & 485A: for meter communication

- h. $\pm 12V$: reserved for customer to use 500mA Max
- i. CAN matching resistance: set DIP switch when using inverters in parallel
- j. Connection for generator auto-start function: GEN (NO, NC)
- k. Reserved: DRY (NO, NC)
- l. LCD UI upgrade port
- m. RSD Terminals

Back View of the Cable Box Knockouts

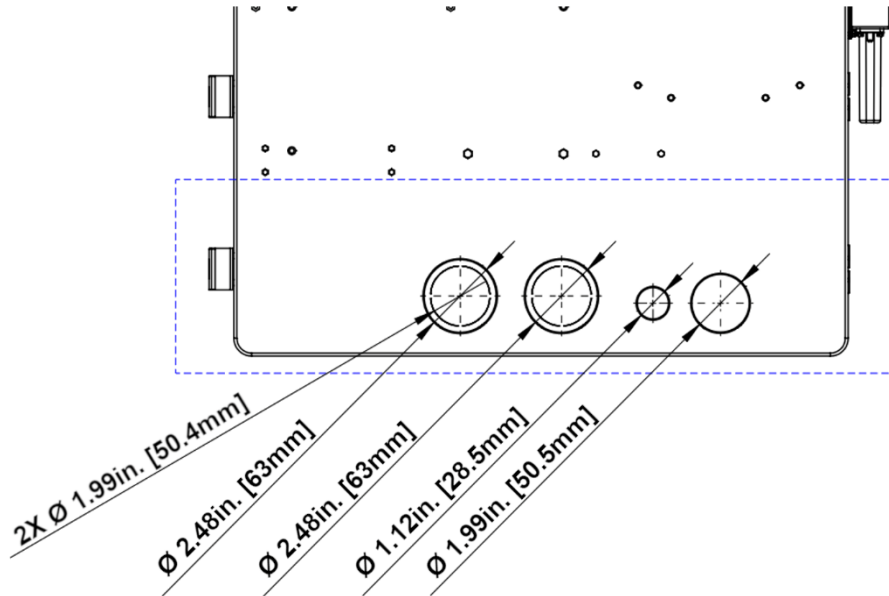

Bottom View of Cable Box Knockouts

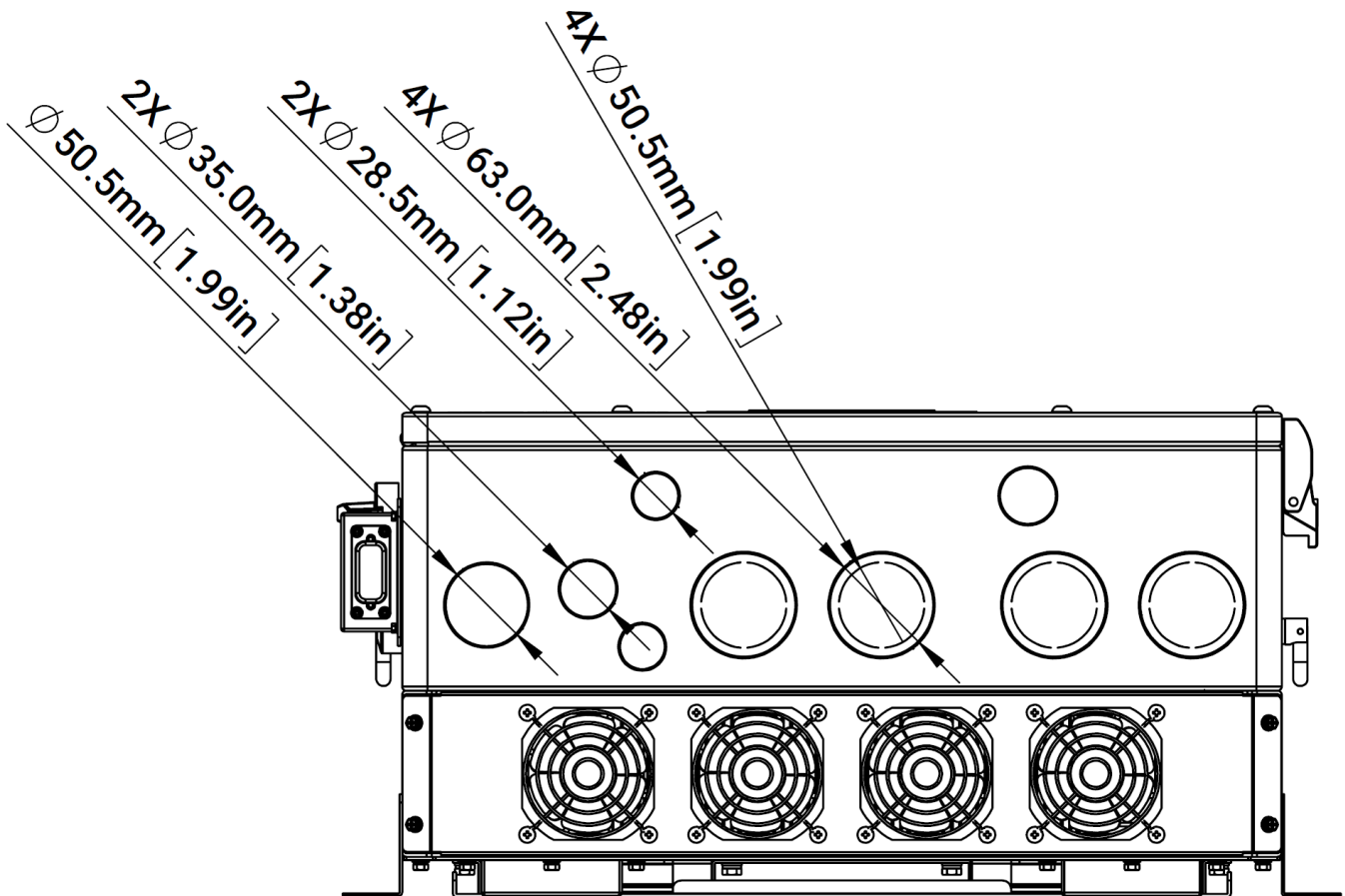

7.1 PV CONNECTION

Cable Requirements*:

Cable Size	Minimum Insulator Voltage
10 AWG – 6 AWG (Max.) (6 mm ² – 16 mm ²)	600V

**Consult installer to ensure that appropriate cable sizing is used due to various factors such as voltage drop and Voc.*



IMPORTANT:

Verify the lowest ambient temperature of the installation location. The rated Voc on the solar module nameplate is obtained at STC (77°F/ 25°C). As the ambient temperature drops, the solar module Voc increases. Ensure the maximum solar string voltage, corrected at the lowest temperature, does not exceed the inverter's maximum input voltage of 600V

PV Input Data	Description	Parameter
DC Input Voltage Range	Range required for the unit to operate up to maximum input	100 – 600VDC
Unit Startup Voltage	Voltage needed for the LCD to turn on	100VDC
Load Output Minimum Voltage	Minimum voltage needed to output power on Load side	>140VDC
MPPT Operating Voltage Range	Range where the MPPT can track	120 – 500VDC
Full Power MPPT Voltage Range	Range where the MPPT operates at maximum capabilities	230 – 500VDC
Nominal MPPT Voltage	The MPPT will operate most optimally at this voltage	360VDC
Maximum Utilized Solar Power	Number of watts the unit can utilize from array after considering all power loss factors	18,000W
Rec. Maximum Solar Input	The suggested PV power input to the device for it to utilize the full 18kW of PV that it can process.	21,000W

String Sizing

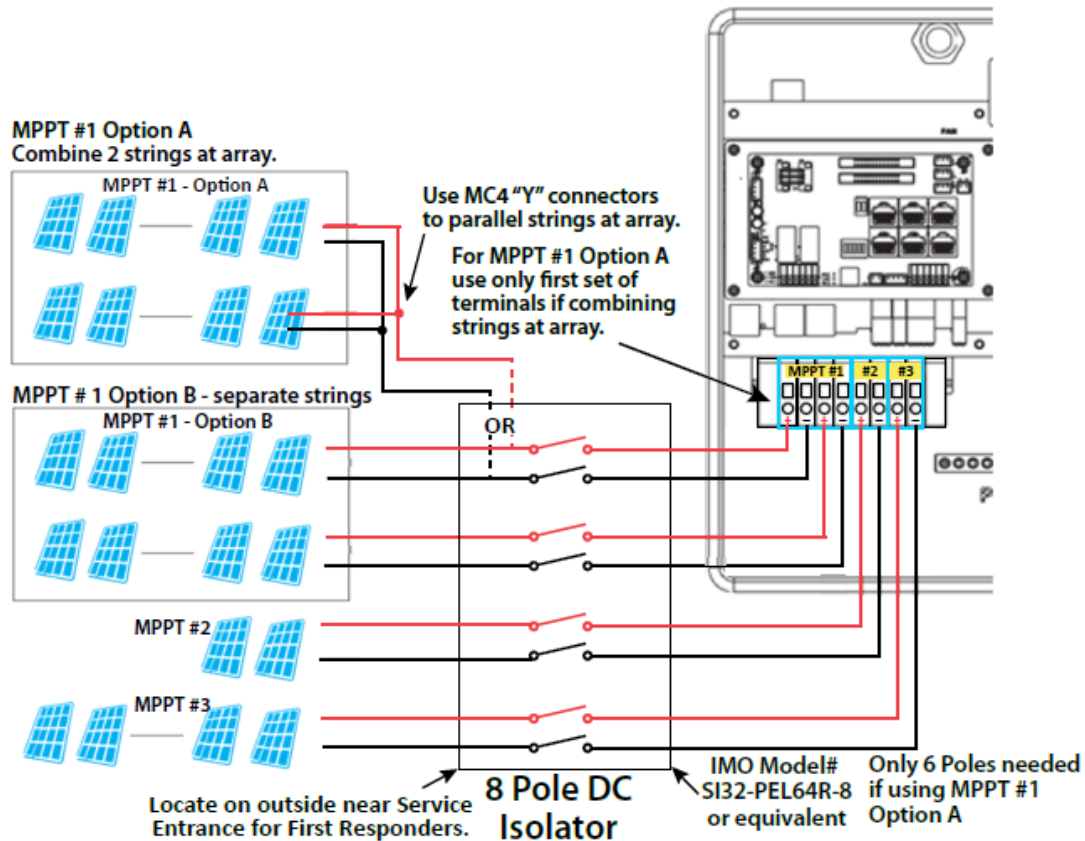

NOTE:

To determine how many modules per string, first verify the lowest possible ambient temperature of the installation location. Next, find the rated VOC, VMP, Isc and Imp of the solar module at 25°C and the temperature coefficients for voltage and power. Then, calculate the highest possible VOC for the entire string when the ambient temperature falls to the lowest possible ambient temperature upon sunrise. To make this calculation, use a string calculator or consult a solar designer or solar electrician. For all modules, the calculations must be verified by consulting a professional.

To use EG4's new solar string sizing tool, navigate to

<https://eg4electronics.com/wp-content/themes/hello-elementor/eg4-solar-panel-string-sizer/>.



DANGER:

DAMAGE WILL OCCUR if the string voltage on a cold, sunny morning exceeds the inverter's maximum input voltage of 600V!

- When solar modules are put in a series string, the voltage multiplies times the number of modules and the amperage stays the same as each module.
- Calculate the maximum current of the string so as not to exceed the inverter's MPPT circuit ratings. Double check if the calculated V_{mp} range is within the 230 – 500VDC optimal MPPT circuit operating range. Consult a solar designer if needed.
- When solar modules are put in parallel, the amperage multiplies by the number of modules and the voltage stays the same as each module.
- The inverter has three MPPT PV charging circuits. MPPT #1 will use up to 25 amps, which means two strings can be paralleled for any modules having less than a 12.5A (I_{mp}) rating. MPPT #2 and MPPT #3 will use up to 15 amps each, so they are usually limited to one string (Unless the module has $<7.5Amps$).
- Each string should ideally contain the same model, brand, and quantity of panels for ease of design, racking, and wiring. However, varying string sizes can be used for unique MPPTs. If two strings are used for MPPT #1 they MUST be the same model, brand and number per string. MPPT#2 and MPPT #3 could differ in model, brand, and number per string (same make/model per string) on the condition that each string complies with the lowest temperature (maximum string number) and maximum amperage calculations above.
- All panels on a series/parallel string should face the same orientation and hopefully be exposed to roughly the same shading across the string. Consideration should be placed on string location and wiring order on the racking to minimize shading effects. One shaded module can disproportionately reduce output for the entire string, so avoiding linear strings in favor of rectangular strings can increase output. Optimizers can also achieve this.
- The inverter will limit the total MPPT current to 25A for MPPT #1, 15A for MPPT #2, and 15A for MPPT #3.



NOTE:

The array can have a higher I_{mp} than the 26A/15A specified, but the MPPTs will not make full use of the extra current. Having an array that can produce more current than the MPPTs can utilize is useful for increasing morning, winter, or cloudy day solar production.

Steps for PV Wiring

1. Ensure all breakers and disconnect switches are in the OFF position before connecting or disconnecting wires. Use a voltmeter to confirm there is no voltage present.
2. Strip off 1/2 in. – 2/3 in. (12.7 mm – 17 mm) insulation on the PV string's positive and negative conductors.
Note: Use wire ferrules for the PV string conductors if they are stranded wire.
3. Insert the conduit fitting into the opening for the PV connection and tighten it from the inside using the counter nut.
4. Route the PV conductors through the conduit fitting and into the inverter.
5. Secure the PV conductors in place into the inverter inputs. Verify that they are secured properly by *lightly* pulling on them.
6. Ensure the conduit and conduit fittings are fastened securely and the cable entry holes are sealed.

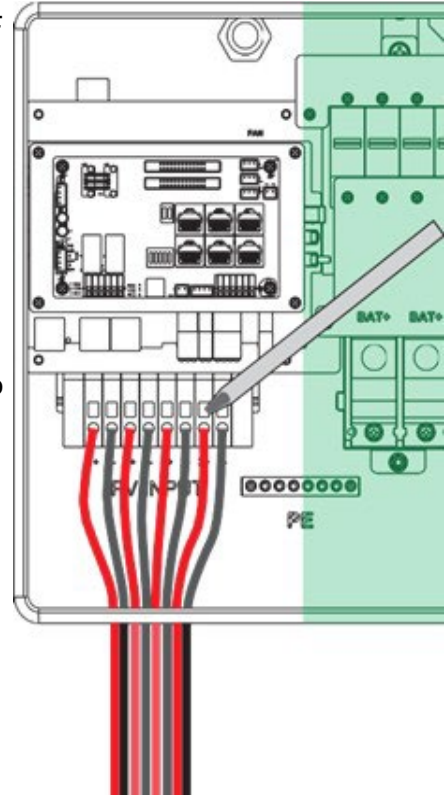

7.2 BATTERY CONNECTIONS

Cable Requirements*

# of cables	Cable Size (90°C)	Max. Distance	Torque for cable connection
2 sets	1/0AWG (53.5 mm ²)	10 ft.	165 in-lbs. (18.6Nm)
2 sets	2/0AWG (67.4 mm ²)	20 ft.	165 in-lbs. (18.6Nm)
1 set	4/0AWG (107 mm ²)	10 ft.	Max. 275 in-lbs. (31.1Nm)
1 set	250kcmil (127 mm ²)	20 ft.	Max. 275 in-lbs. (31.1Nm)

*Suggestions based on distance and battery bank quantity

Battery Power Cable Connection

1. Place all breakers in the OFF position before connecting or disconnecting wires. Ensure that there is no voltage present with a voltmeter.
2. Strip 3/5 in. – 4/5 in. (15 mm – 20 mm) insulation from the cable end.
3. Route the battery power cable, connecting positive to BAT +, and negative to BAT -.
4. Secure the conduit fitting to the enclosure using the counter nut.
5. Fasten battery positive and negative cables to the mechanical terminals according to the markings with an M8 hex wrench.

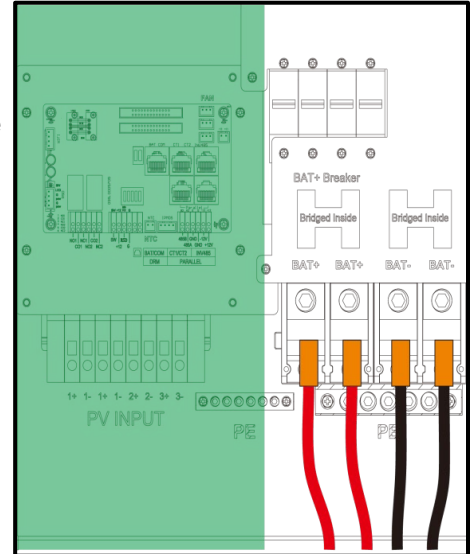

Battery Communication Cable Connection

1. Use the included battery communication cable to connect the battery to the inverter and choose “Lithium” as the battery type*. Select the “Lead-Acid” setting if the lithium battery cannot communicate with the inverter. The battery communication port on the inverter is an RJ45 socket with the pinout for the RJ45 plug shown on the following image. Users can make the communication cable according to the inverter pin description below and the correct pinout of the communication port on the battery. The inverter supports both CAN and RS485 communication.

**For inter-battery communication and battery bank setup with EG4® batteries, refer to the respective battery manual.*

Pin	Description
1	BAT RS485 B
2	BAT RS485 A
3	NC
4	BAT CAN H
5	BAT CAN L
6	NC
7	NC
8	NC

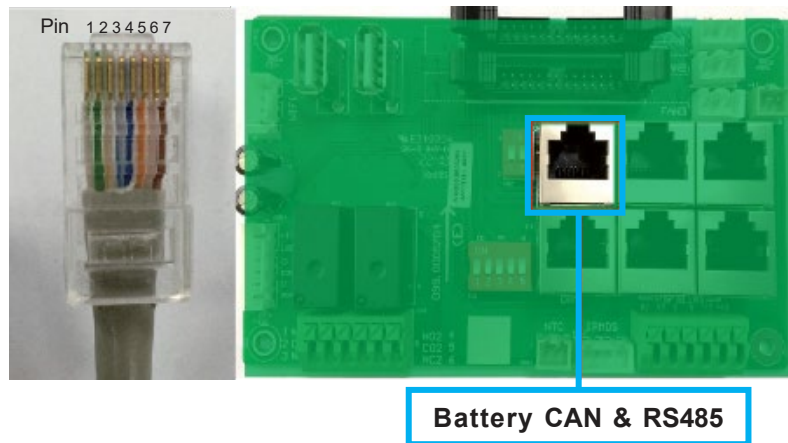

- After connecting the battery power and communication cables, enter the “Advanced” settings to choose the battery type and brand. When prompted, enter “00000” as the password to enter the settings menu.

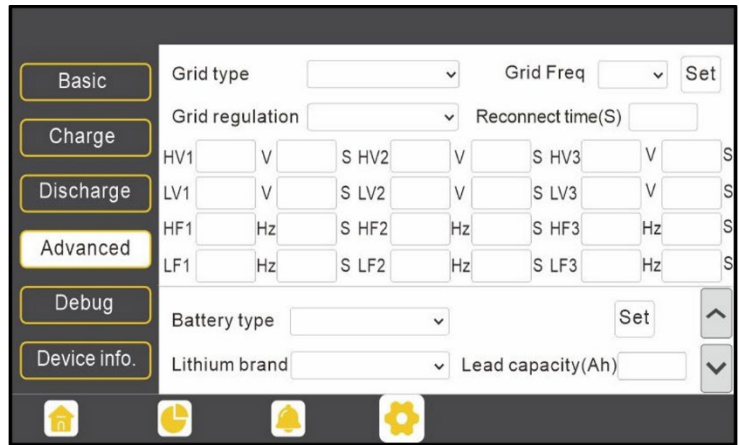

NOTE:

If using EG4® LifePower4 V1 batteries in the system, a firmware update is required for closed-loop communications. Contact the distributor for this file or navigate to <https://www.eg4electronics.com/> for the most recent updates and documentation. For communication with EG4 batteries, select “Lithium” under “Battery Type” and then select “1” under “Lithium brand”.

- If using LifePower4 V1 batteries or RS485 communications, use “0:EG4” under “Lithium brand”.

For Lithium Battery:

Ensure that the lithium battery being used is compatible with the inverter. EG4® strongly recommends using closed-loop communications between the battery and inverter. Contact the distributor or support@eg4electronics.com for an updated battery closed-loop communications list. If using multiple battery modules with the inverter, the inverter communication cable must be connected to the master battery. Check with the battery supplier for battery master and slave settings.

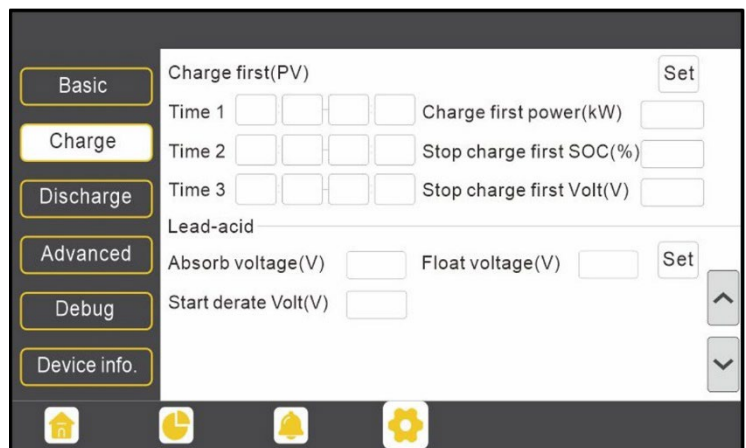

For Lead-Acid Battery:

The temperature sensor for Lead-Acid batteries is optional. There are three stages for lead-acid battery charging.



Battery Wiring Diagrams

7.3 AC CONNECTIONS

When sizing AC wires, adhere to the following information.

Cable Requirements:

Terminal Connection	Wire Size	Torque Values
GRID	6 – 4/0AWG (26.7 mm ² – 107 mm ²)	95 – 165 in-lbs. (10.7Nm – 18.6Nm) depending on wire
GEN	Size according to generator output	95 – 165 in-lbs. (10.7Nm – 18.6Nm) depending on wire
LOAD	6 – 4/0AWG (26.7 mm ² – 107 mm ²)	95 – 165 in-lbs. (10.7Nm – 18.6Nm) depending on wire

Ground-Neutral Bonding

The information below describes the nature of the ground and neutral in the inverter and their relationship to the system. Always consult with an installer or a licensed electrician to ensure that the right configuration is being used:

- The neutral line is a solid connection between AC input and AC output (known as a Common Neutral Architecture).
- The neutral line between the AC input and AC output is never disconnected.
- **The inverter never creates a ground-neutral bond in any mode of operation.**



IMPORTANT:

The system should have only one ground-neutral bond (this is typically the Main Bonding Jumper located at the first grid system disconnect).

After connecting all AC wiring, put the build in LOADS breaker back to the ON position before providing power to the load.

CT Connection

1. Before connecting or disconnecting AC wires, ensure all breakers are in the OFF position. Check that there is no voltage present with a voltmeter.
2. Strip off 3/5 in. – 4/5 in. (15.2 mm – 20.3 mm) insulation from the AC cables.
Note: Use wire ferrules if the cables are made of fine stranded wires.
3. Secure the conduit fitting to the enclosure using the counter nut of the fitting.
4. Fasten the GRID and LOAD cables to the terminal block in accordance with the terminal labels using an M8 hex wrench (For ground terminal, use an M5 hex wrench.).
5. Secure conduit to the conduit fitting.
6. Check that the cables are connected properly. Take appropriate measures to ensure that the conduit and conduit fitting are properly secured and seal the cable entry holes.

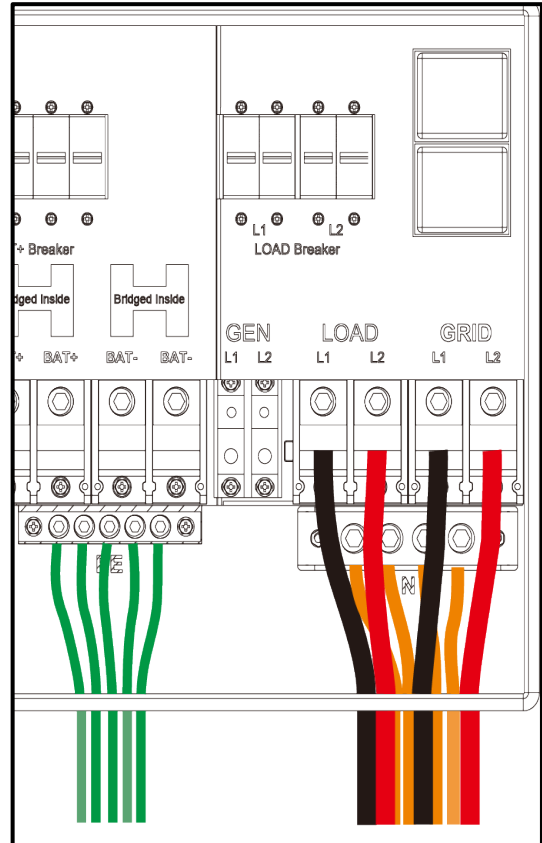

WARNING:

Do not install the CTs when using this inverter with EG4® GridBOSS. If installed, the inverters current output can show false readings in EG4 Monitor Center.

To measure the power imported from and exported to the grid, a pair of CTs or one three-phase meter must be installed at the service entry point in or near the main service panel. Two CTs are provided with each inverter.

CT Type:

Model: CTSA024-300A/100mA **Technical Specification:** 240V/208V, 300A/100mA

CT Port Pin Definition

The CT interface for the two (2) CT connections is an RJ45 port. The two (2) CTs come with premade plugs that can be connected directly to the port.

Pin	Description
1 – 4	Reserved
5	CT2N
6	CT2P
7	CT1N
8	CT1P

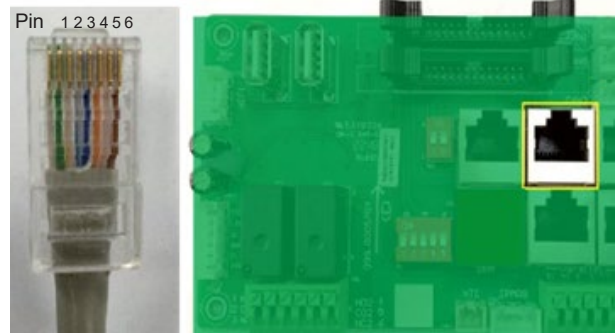

Refer to the connection diagram to the right for the correct position of the CTs. Clamp the 2 CTs onto the L1 and L2 wires at the service entry point in the main service panel.

The arrows on the CTs must point toward the inverter and be placed on the proper line based on their number. (CT 1 for L1, CT 2 for L2)

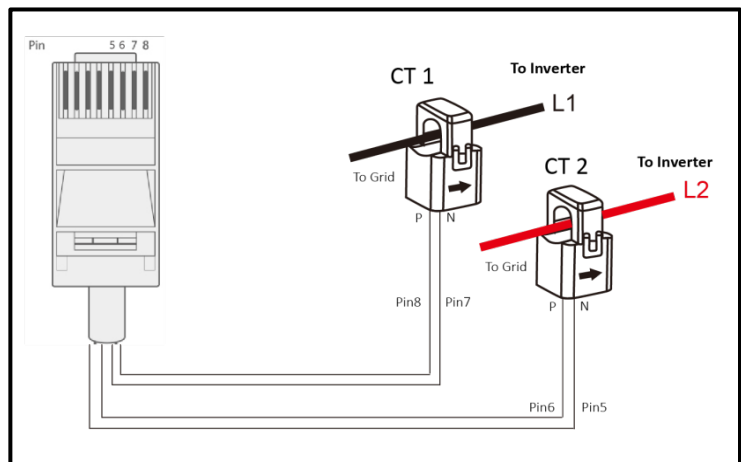

CT Clamp Ratio:

The inverter supports three ratios of CT clamps: 1000:1, 2000:1, and 3000:1. The included CT is 3000:1.

If using a 3rd party CT, ensure that the CT ratio is of the supported types. Be sure to select the correct CT ratio setting on the inverter.

Black= L1

Red= L2

Orange= Neutral

Grey= Communication Cable

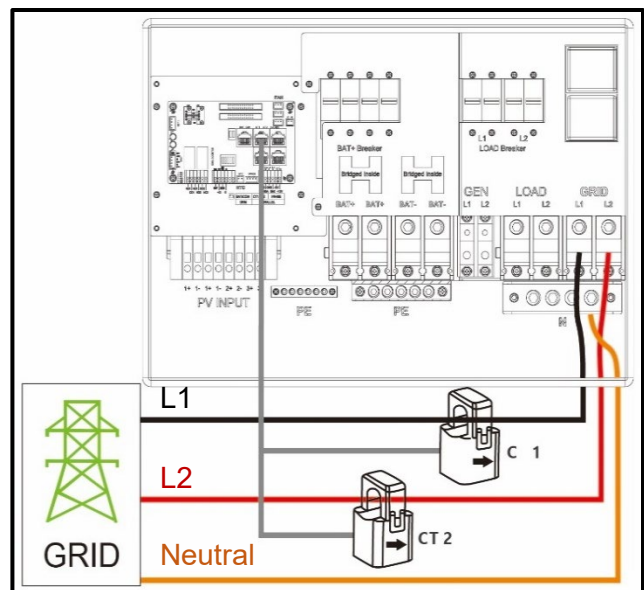

Extending the CT Clamp Cable

The CT wires can be extended with a common ethernet cable if they are not long enough. An RJ45 adapter is needed for the extension. The CT wires can be extended up to 300 ft. (around 90 m).

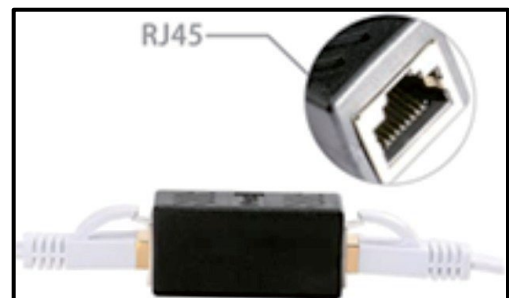

7.4 GENERATOR CONNECTIONS

Generator System Connection

This hybrid inverter can work with a generator by connecting it to the GEN terminals on the inverter. When the generator is started, it will supply the inverter with the generator's maximum power. If the generator's power is not adequate to power all loads, the inverter will pull from the battery bank as supplemental power.

Generator requirements:

1. Generator should be a 120/240VAC, 60Hz generator.
2. Generator capacity should be **between 6kW – 21.6kW**.
3. Generator THD should be <3%.

Connecting the Generator Start Signal (2-Wire Start)

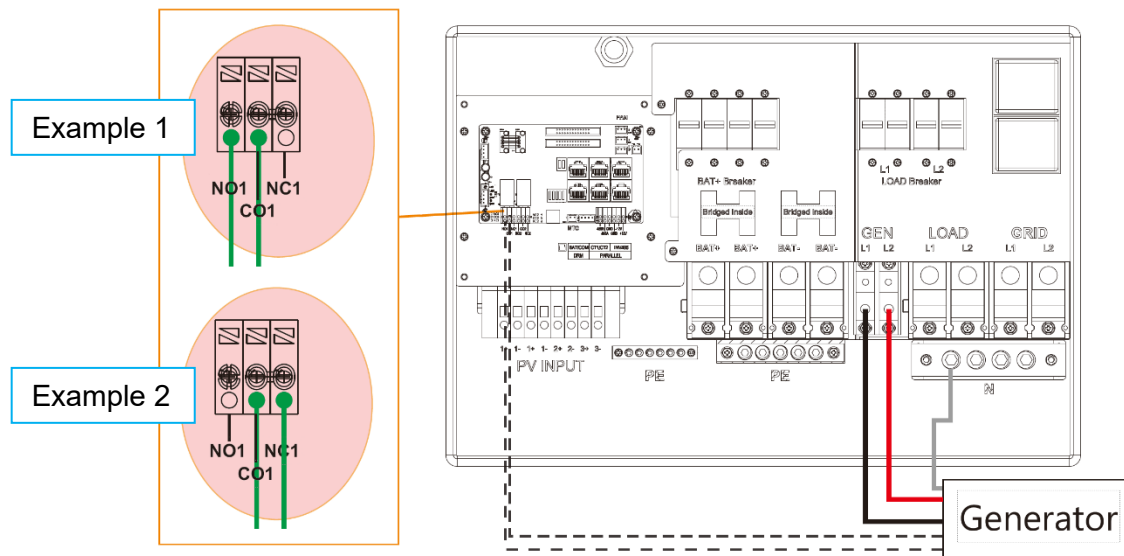

When the generator is started, all the loads connected to the LOAD terminals will be supplied by the generator while still charging batteries; the generator will become the primary source of power for the inverter. The pass-through relay on the generator terminal is 90A. When the generator is on, ensure the total load and charge current does not exceed 90A. The generator start signal will be connected to the COM board GEN Normally Open (NO1 and CO1), or Normally Closed (NC1 and CO1) terminals, if users want to start generator remotely. See diagram above for 2 examples.

Generator 2-Wire Start Specs:

- Maximum Voltage 30VDC, 277VAC.
- Maximum NO Contact Current: 5A
- Maximum NC Contact Current: 3A

Generator Start and Stop Settings

The “Operating Mode” setting will determine whether the system will use battery SOC or battery voltage to start or stop the generator.

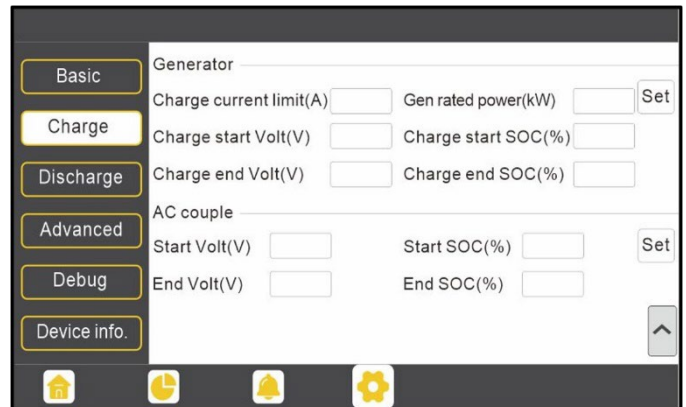
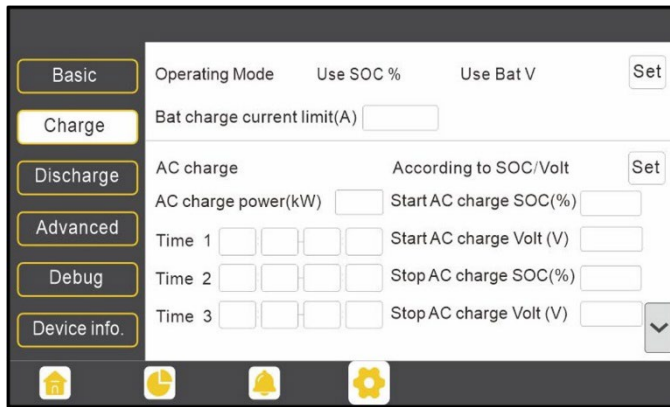

Generator Start Conditions

The generator will start when utility fails and one of the following conditions is met:

- When battery bank is discharged to the cut-off setting OR
- There is a force charge request from battery bank OR
- When the battery voltage or SOC is lower than the generator “Charge start Volt/SOC” setting.

Generator Stop Conditions

When battery voltage or SOC is higher than the “Charge end Volt/SOC” settings.

7.5 OFF-GRID WIRING

The 18kPV can fully function in off-grid only mode. It does not need the utility or generator to function. Purely off-grid systems that do not have access to the utility should strongly consider having a 2-wire start backup generator for extended cloudy periods (8 – 12kW diesel recommended per 18kPV inverter, 21kW max. per inverter). Off-grid systems should have robust battery banks sized to ensure multiple days of power and to reduce generator run time.

The 18kPV can also utilize AC coupled solar input through the GEN port in purely off-grid systems.

The generator can then be connected to the GRID port.

The 18kPV can accept up to 90Amps (21kW) of generator power and will pass through all available power to the loads. Therefore, the LOADS subpanel can be sized up to the size of the backup generator with a 60 amp minimum per inverter.

7.6 AC COUPLING INSTALLATION CONNECTION

The inverter can accept PV solar inputs to both MPPT channels and AC coupled solar input at the same time. The AC coupled solar input can be up to 90A of AC power or 21.6kW of solar. The MPPT channels can handle up to 18kW of solar, with 12kW available to feed back to the grid. Therefore, up to 33.6kW of AC power could be sent back to the grid. For this amount of back feed, users will need either a feeder tap or supply side tap as the point of utility interconnection. The existing solar system is connected to the inverter's GEN terminal.

After the AC couple function is enabled:

When the grid is on, the 18kPV sends the AC power of the grid-interactive inverter to the loads and battery bank. Any remaining energy will be exported to the grid.

When the grid is off, the 18kPV enables the grid-interactive inverter to provide PV power to loads and battery bank. Loads will be supplied by PV first, then battery power. When solar power exceeds the sum of loads' power consumption and maximum battery charging power, the inverter will signal the grid interactive inverter to reduce power via the frequency-shifting, power-reduction mechanism.

What is frequency-shifting power reduction?

All UL1741SA compliant grid-interactive inverters have the Frequency-Watt feature, which requires the grid-interactive inverter to reduce power with increasing grid frequency. The power will drop to zero before the over-frequency trip threshold is reached.

When the grid is down and the hybrid inverter requires an AC coupled inverter to reduce power, it simply shifts the output frequency up slightly, and the grid-interactive inverter will limit its output power accordingly after sensing this frequency shift.

When the grid is up, the frequency is dictated by the grid and the hybrid inverter will reduce exported power if the frequency goes up.

AC Coupling Settings: The “AC couple” setting must be enabled when connecting an existing on-grid system to the GEN terminal.

Start SOC/Voltage (%/V): The SOC or Voltage at which the AC coupled inverters are turned on when in off-grid mode (50% to 70% recommended).

End SOC/Voltage (%/V): The SOC or Voltage at which the AC coupled inverters are shut down when in off-grid mode (90% recommended).

When on-grid and export to grid is enabled, the AC coupled inverter will always be on, and it will sell any extra power back to the grid. Ensure “Grid Sell Back” is allowed with the utility provider when using AC coupled PV arrays on-grid.



NOTE:

It is recommended to keep the Start V/SOC and the End V/SOC within 5 – 10% of each other for optimal operations when utilizing AC coupling.

If looking to frequency shift when AC coupling, it is recommended to set the Start SOC to 99% and the End SOC to 100%.

7.7 PARALLEL SYSTEM CONNECTION

Connections for Parallel System

The hybrid inverter supports parallel connection to expand power and energy capacity to suit different usage scenarios. **Up to 10 units can be paralleled to reach a capacity of 120kW.**

The parallel wiring diagrams are as follows. The manual bypass switch connects the loads to LOAD panel as default. If the inverters fail, users can switch the loads to utility. **Contact the inverter supplier for more detailed guidance on paralleling the system.**



REMINDER:

Put the CAN communication pin to ON status for the first and the last inverter and OFF for inverters in between. Both switches in the “ON” position translates to address 1. Both switches in the “OFF” position translates to address 0.

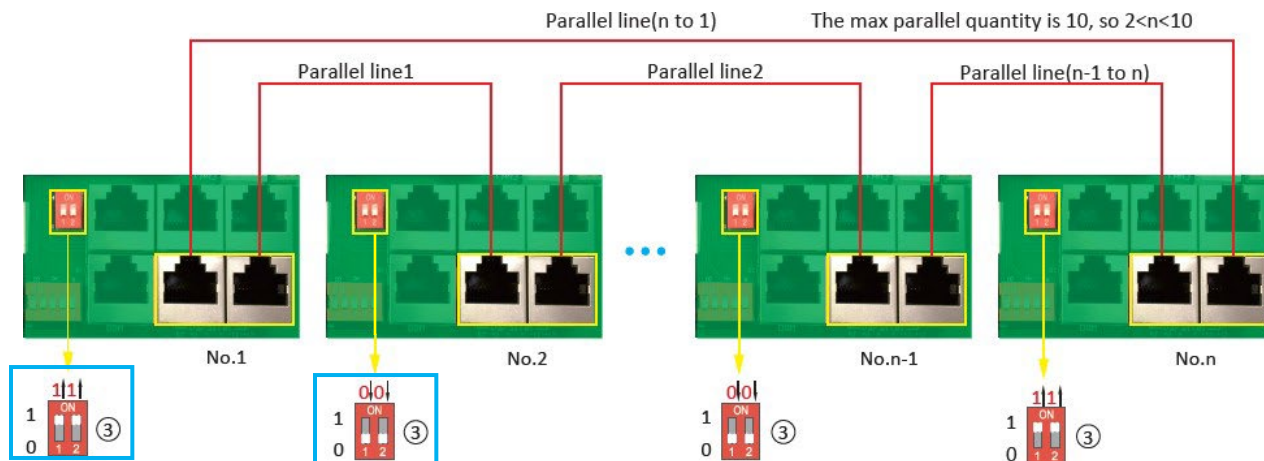



REMINDER:

If the inverter-to-inverter paralleling cable needs to be extended, ensure the cable is a straight-through CAT5 and up cable. See image below for reference

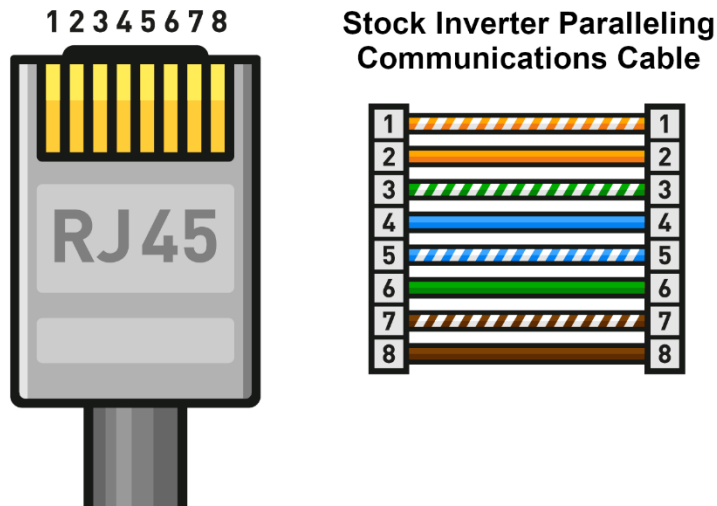

Parallel Information Display

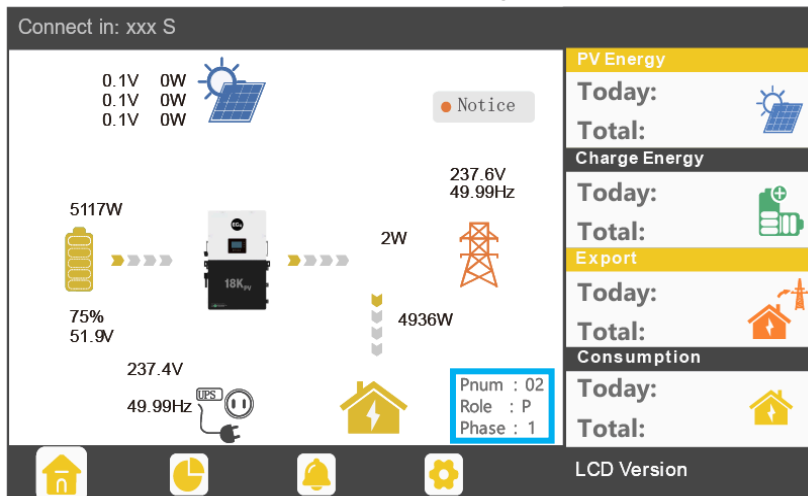

The information in the blue box shows the parallel information:

- **Pnum:** 01 – 10
 - a. Display number of parallel units
- **Role:** P or S:
 - a. P = Master
 - b. S = Slave
- **Phase:** 1 – 3:
 - a. 1: U Phase
 - b. 2: V Phase
 - c. 3: W Phase

Notices for parallel system:

- Ensure that the generator is connected to all inverters in parallel (if available).
- If the number of PV panels connected to each inverter cannot be divided evenly, it is recommended to have more PV panels on the master inverter.
- The values shown on the LCD of each inverter represent the inverter's contribution to the system, **not the system's total**.

Parallel Configuration:

1. Verify that all inverters are updated with the latest firmware. Contact the distributor to confirm the latest version.
2. Make sure the power cables and parallel communications cables have been wired correctly and verify the DIP switch configurations are correct.
3. Power on the inverters and set them to standby via the “Basic” page in the settings.
4. Verify that the inverter status is “0”.
5. Select which unit to set as the Master by selecting “1 phase primary” in “Advanced” settings. Set the others as “Slave.”
6. Ensure all inverters are set to “U Phase.”
7. Enable “Share Battery” on all inverters and ensure the communication cable from the battery is connected to the Master unit.

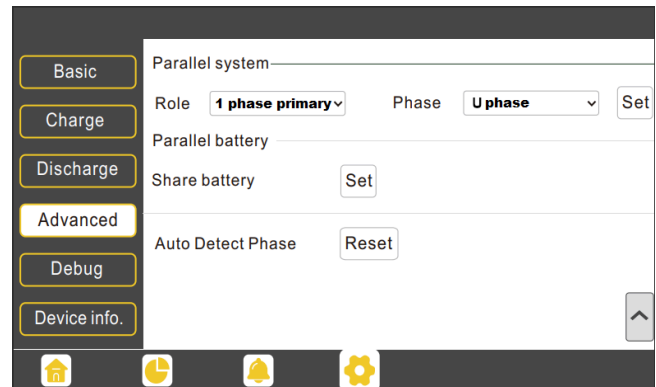
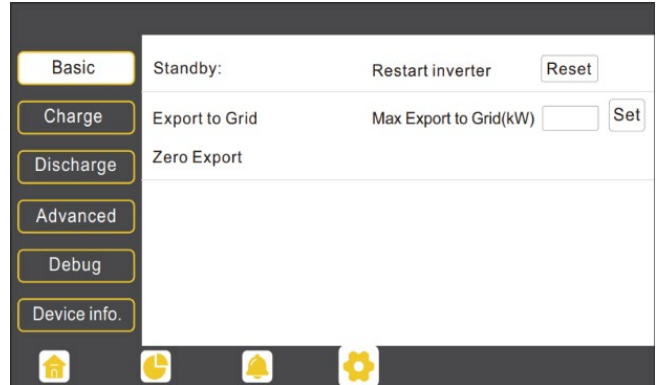

Commissioning Steps:

1. Turn on the battery and make sure the communication works on all units.
2. Check the parallel info via the Home page.
3. Turn on the “Off-grid output” function in the “Advanced” page.
4. Before connecting load to load output terminal, check the output of L1 and L2, and L1 and N.
5. Add small loads to the load output and verify power output.
6. Finish the commissioning.

7.8 GRID, LOAD, AND AC CONNECTION

This inverter can be used in 120/240V or 120/208V phase systems. This inverter has passed the main grid connection regulations in the U.S. Users can choose the different grid type and regulation in the “Advanced” program.

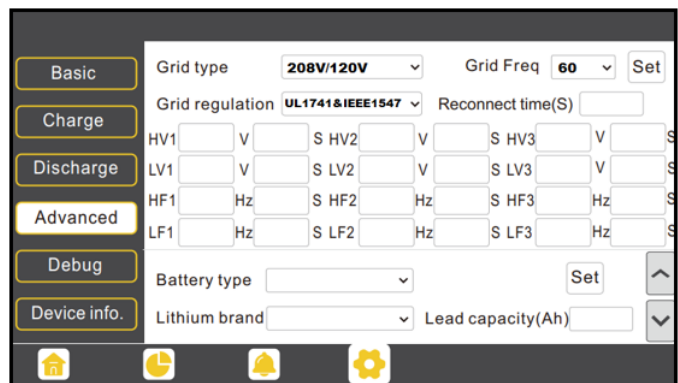

IMPORTANT:

Make sure the safety standard and grid type configurations are consistent.

7.9 GRID AND LOAD CONNECTIONS FOR SPLIT-PHASE SERVICE

The inverter can withstand up to 8kW of imbalance between L1 and L2. However, the loads should be balanced as much as possible to avoid damaging the load side equipment.

The inverter can be connected to the load side of the service disconnect. This means if the busbar rating in the main panel must meet the NEC705.12(B)(3) requirements. Otherwise, a Line side connection can be made to avoid an expensive main panel upgrade.

The default setting for split-phase is 120/240; the inverter is capable of 120/208 under electrician or installer advisement.



DANGER:

There is a very real danger of overloading the service entrance wires with supply side taps (refer to NEC 220). Users could essentially be adding loads to a possibly already fully loaded service entrance.

DO THIS ONLY UNDER ADVISEMENT OF AN ELECTRICIAN AND/OR INSPECTOR.

7.10 WIRING DIAGRAMS

For specific use cases, scan the following codes:



System Wiring Diagrams



System Wiring Diagrams
Batteries



System Wiring Diagram
AC Coupling



System Wiring Diagram
Generator



System Wiring Diagram
Smart Loads



MPPT String
Configuration

Partial Home Backup with Supply Side Tap

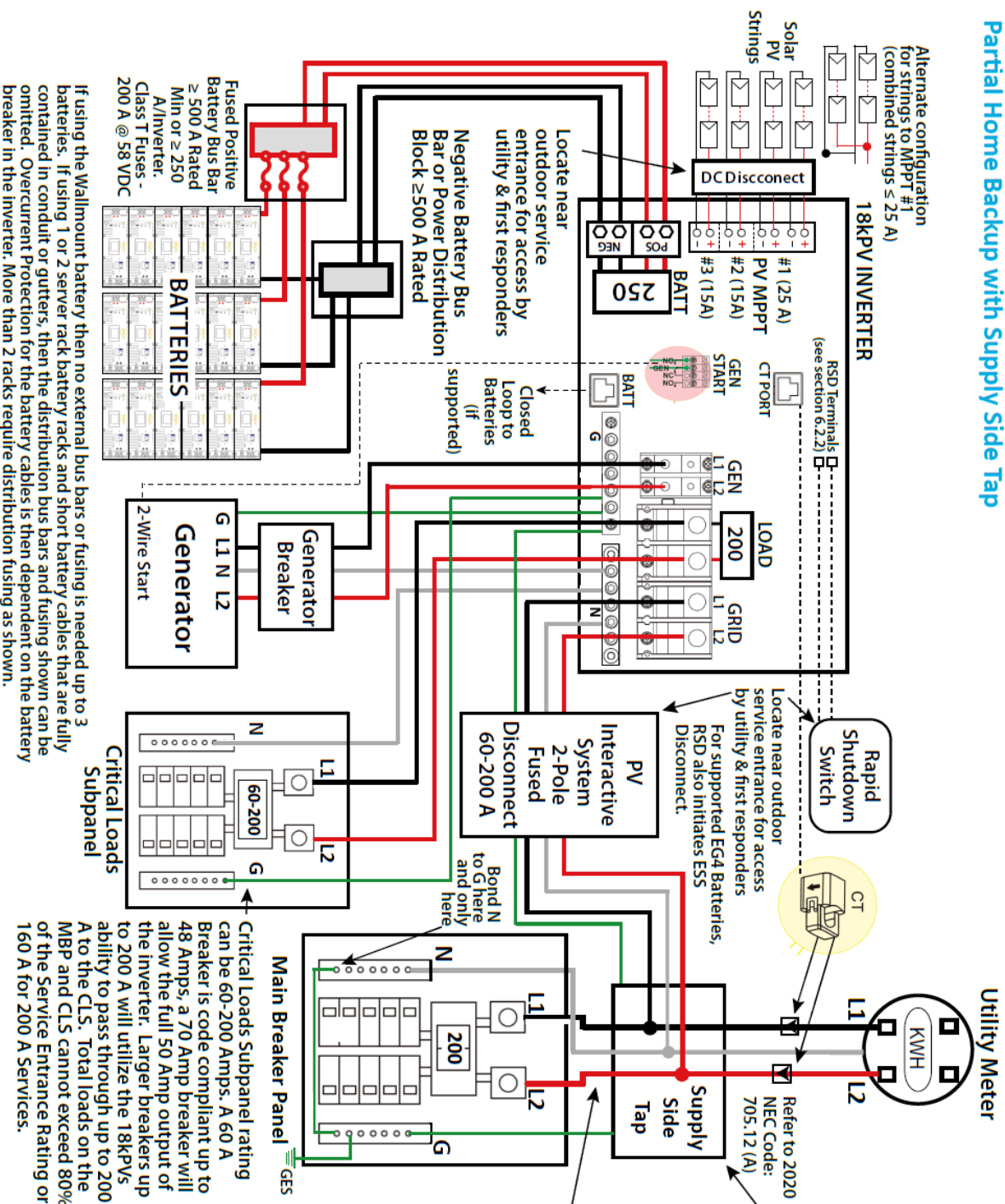

SUPPLY SIDE TAPS - If your home has - like most homes do - a 200 Amp Rated Main Panel and a 200 Amp Main Breaker and therefore cannot use a 60 or 70 A Backfed Breaker (see Backfed Breaker diagram) then a supply side tap with a Critical Loads Subpanel may be your solution. This only works when you can find a place in your meter main that will allow your electrician to make a tap between the utility meter and the main 200 Amp breaker. Some Meter-Mains have an actual cable that runs between the meter socket outputs and the Main Breaker allowing for a KUP-L-type tap or equivalent.

CAUTION: There is a possible danger of overloading your service entrance conductors with this configuration. You will be essentially adding a 50 A battery charger to your - perhaps already fully loaded Service Entrance without any breaker capacity to protect it. Check with your electrician or AHJ to approve this installation.

Upgrading your Service Entrance to the Feeder Tap configuration. (See Feeder Tap Diagram).

Refer to NEC Code:
 2020: 705.12 (A) & (B)
 2023: 705.11 and 705.12

Note: The amperage rating of the PV Interactive System Disconnect should be at least 70 Amps and should match the amperage of the Critical Loads Subpanel's Main Breaker. Consult your electrician for sizing of the Supply Side Tap conductors, the PV Interactive System Disconnect, and the Critical Loads subpanel.

If using the Wallmount battery then no external bus bars or fusing is needed up to 3 batteries. If using 1 or 2 server rack battery racks and short battery cables that are fully contained in conduit or gutters, then the distribution bus bars and fusing shown can be omitted. Overcurrent Protection for the battery cables is then dependent on the battery breaker in the inverter. More than 2 racks require distribution fusing as shown.

Whole Home Backup using a Feeder Tap

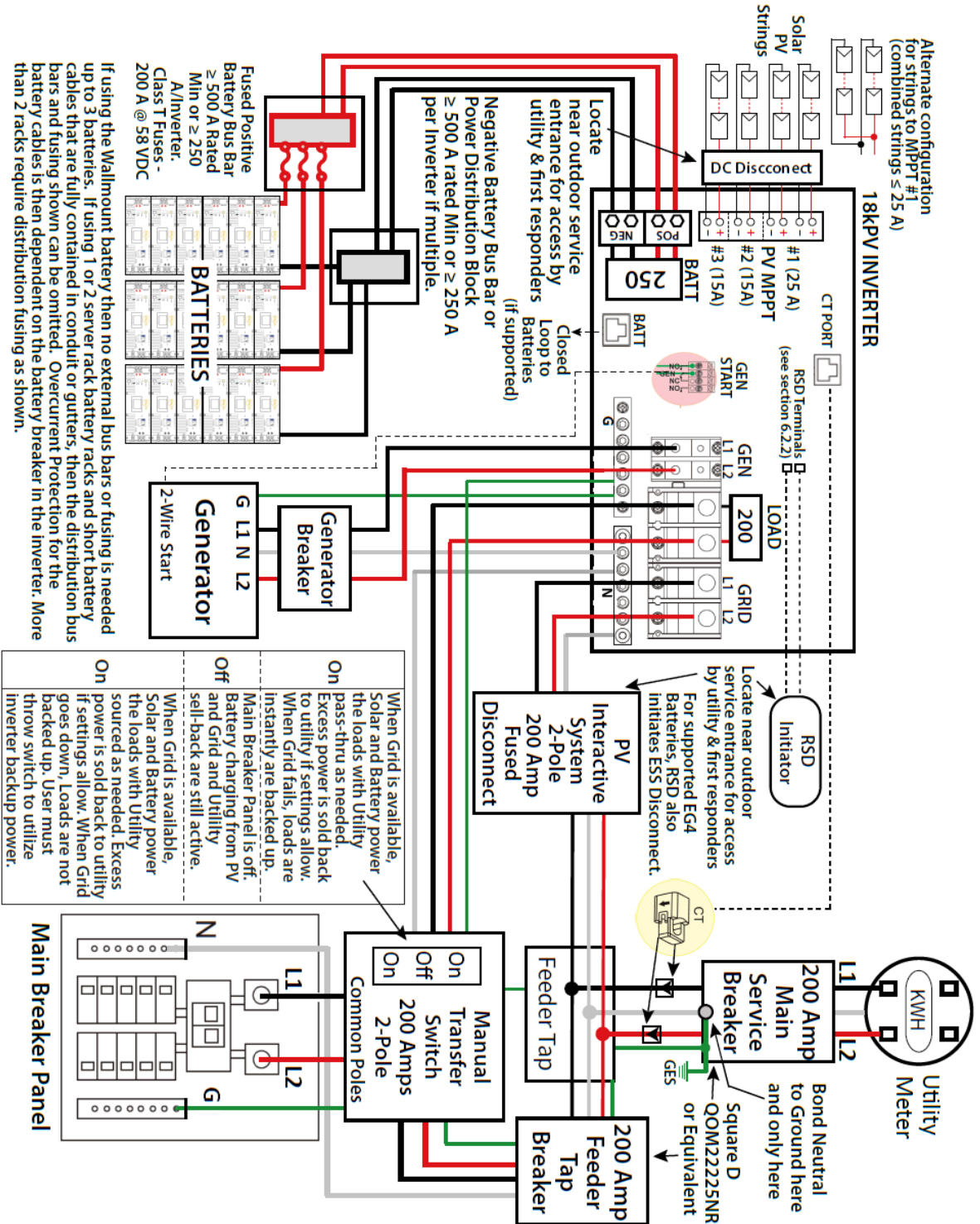

FEEDER TAPS ARE THE IDEAL AND SAFEST WAY TO TIE YOUR INVERTER TO THE UTILITY GRID while achieving whole home backup, full solar backed, and full battery charging capability while fully protecting your home's wiring.

However, Feeder Taps must be installed correctly.

Refer to NEC Code:
2020: 705.12 (B)(1&2)
2023 705.12

The Main Service Breaker and the Feeder Tap Breaker must be a stand-alone breaker - not a load center. There can be no loads between the Utility Meter and the Feeder Tap. If the Main Breaker Panel has a Main 200 Amp Breaker and it is within 10' of the Feeder Tap then some inspectors will allow omitting the 200 Amp Feeder Tap Breaker. However if this is done the conductors between the Feeder Tap and the Main Breaker Panel - as well as the Manual Transfer Switch are subject to the combined ampereage of the Utility (200 Amps) and the backfeed capability of the inverter (50 Amps) while only being rated to 200 Amps. Best to include that breaker as shown.

Feeder Taps should be done by a professional electrician. Ilisco KUP-L-Taps are recommended but must be adhere strictly to installation instructions with proper torque applied measured by a torque wrench. Alternatively a Polaris or Burnby Insulated MultiTap Connector can be used but these need to be torqued twice - once upon installation and once 24 hours later.

3 x 18kV Inverters - Whole House Backup with Feeder Tap - 120/240 VAC

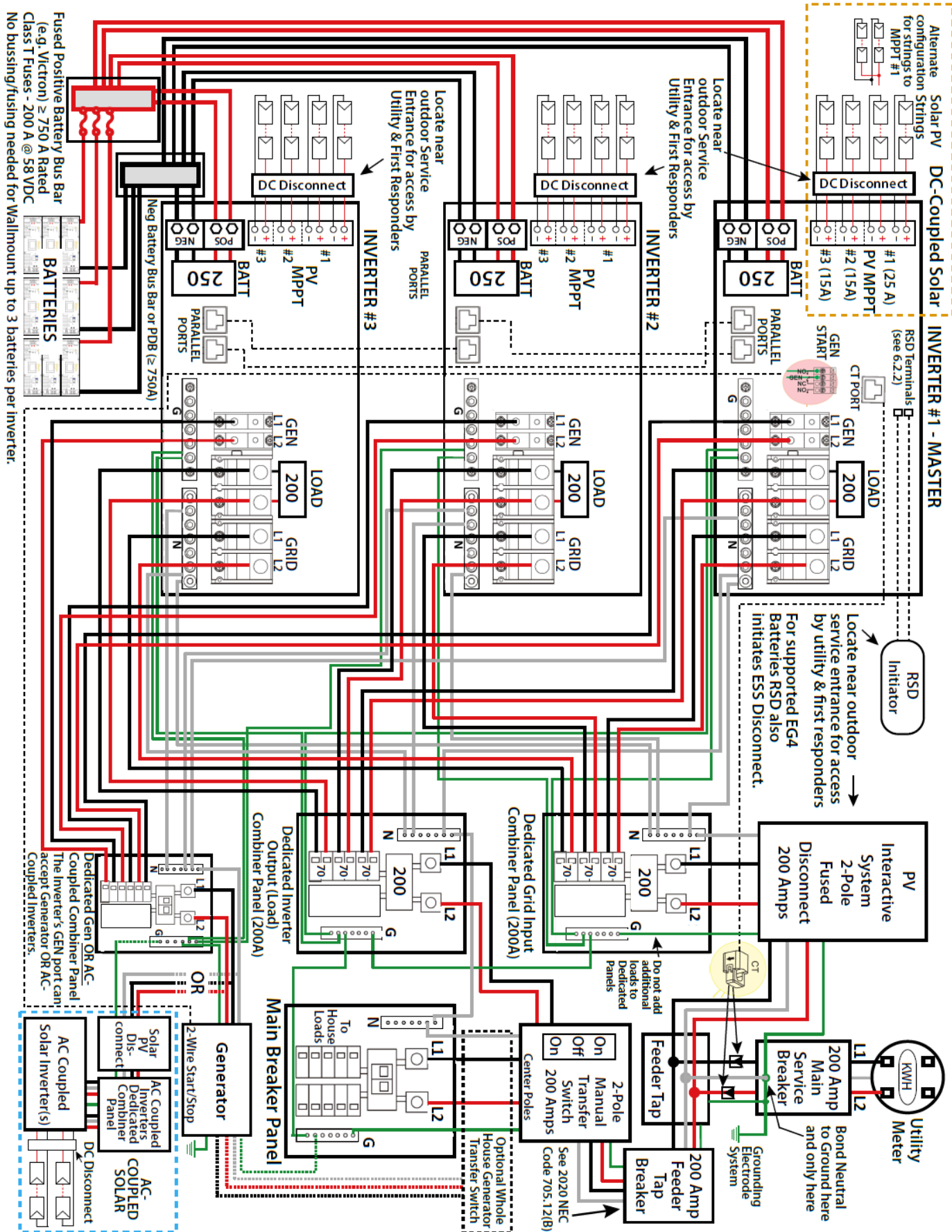

3 x 18kV Inverters - Whole Service Backup with Feeder Tap - 3 phase -120/208 VAC

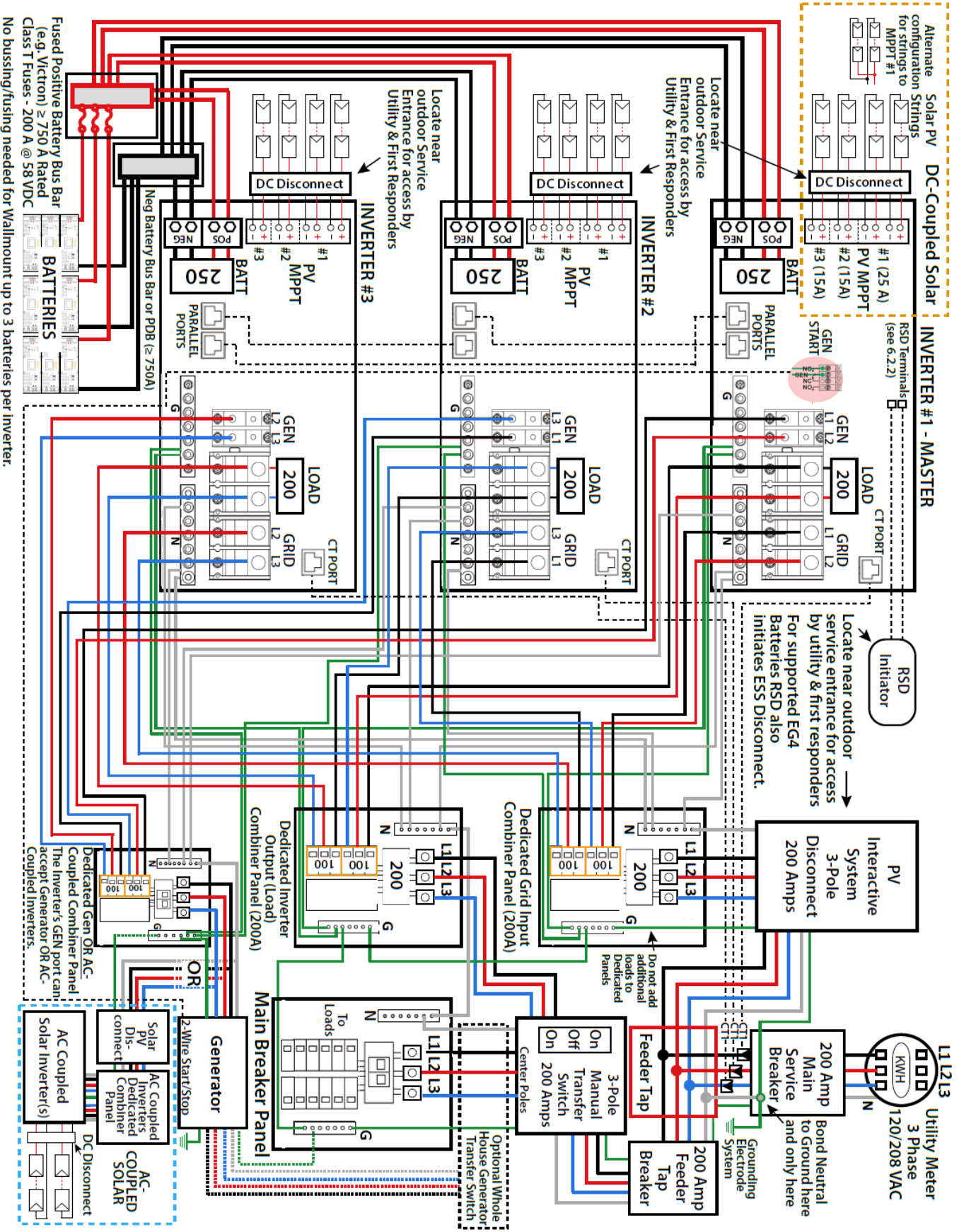

Alternate Solar PV configuration strings for strings to MPPT #1

Locate near outdoor service entrance for access by utility & first responders

Locate near outdoor service entrance for access by utility & first responders

Locate near outdoor service entrance for access by utility & first responders

Fused Positive Battery Bus Bar (e.g. Victrol) ≥ 750 A Rated Class T Fuses - 200 A @ 58 VDC

Neg Battery Bus Bar or PDB (≥ 750A)

BATTERIES

No bussing/fusing needed for Wallmount up to 3 batteries per inverter.

OFF-GRID

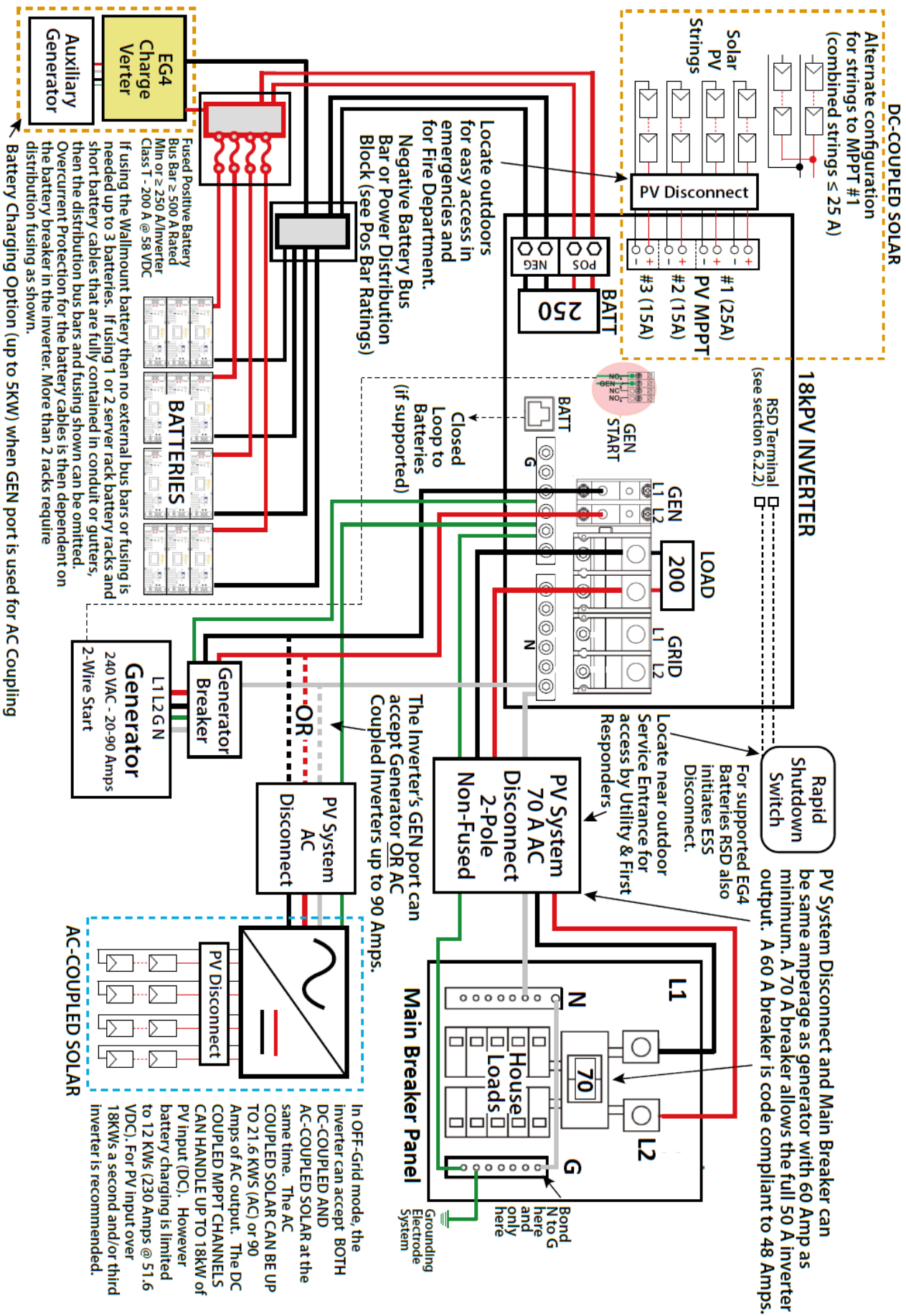

AC COUPLING

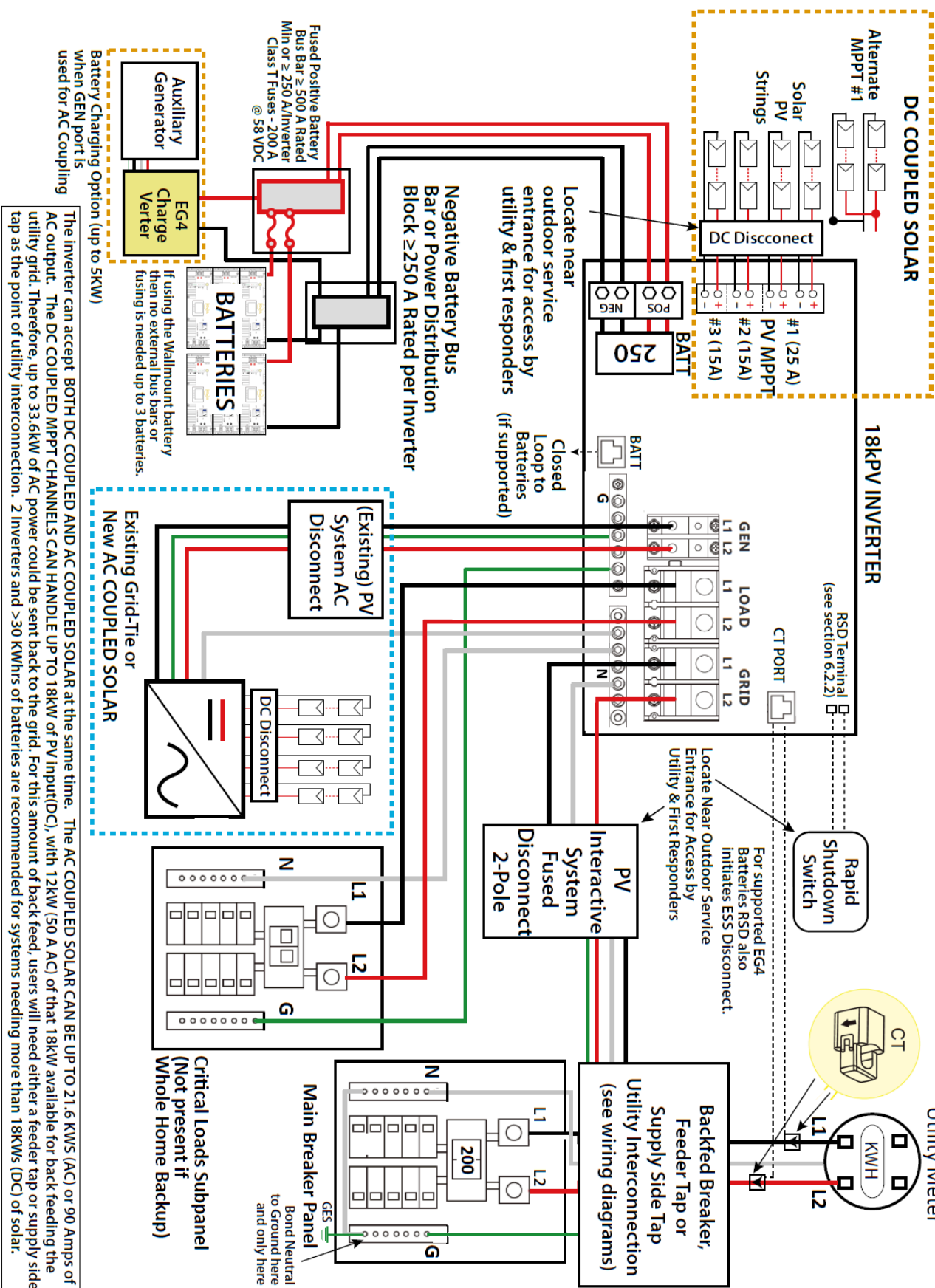

The inverter can accept BOTH DC COUPLED AND AC COUPLED SOLAR at the same time. The AC COUPLED SOLAR CAN BE UP TO 21.6 KWS (AC) or 90 Amps of AC output. The DC COUPLED MPPT CHANNELS CAN HANDLE UP TO 18kW of PV Input(DC), with 12kW (50 A AC) of that 18kW available for back feeding the utility grid. Therefore, up to 33.6kW of AC power could be sent back to the grid. For this amount of back feed, users will need either a feeder tap or supply side tap as the point of utility interconnection. 2 Inverters and >30 kWhs of batteries are recommended for systems needing more than 18KWs (DC) of solar.

8. MONITOR SYSTEM SETUP

Besides the LCD screen, the inverter can be programmed and monitored with the EG4® Monitor Center Website (monitor.eg4electronics.com) and the EG4 Monitor App. The following sections discuss the various ways to communicate with the inverter.



Monitor Center
Website



Monitor Center
Overview



Monitor App
for Android



Monitor App
for Apple

8.1 WI-FI/4G DONGLE CONNECTION

A Wi-Fi/4G dongle can be used to monitor the inverter and remotely view the monitoring data on a computer or smart phone. Attach this module by plugging it in to the side of the inverter and securing it with the four (4) Phillips head screws (see image below).

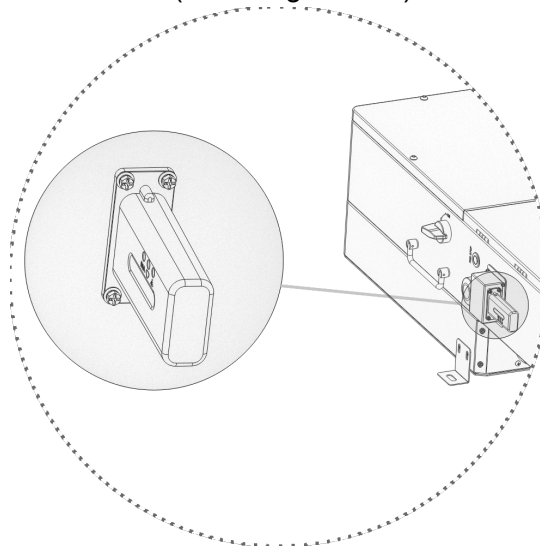

8.2 CONNECTIVITY REQUIREMENTS

Due to certain limitations of the Wi-Fi Dongle, please ensure that the home Wi-Fi network signal and security settings meet the following requirements:

- The Wi-Fi dongle only supports wireless networks in the 2.4GHz frequency band. If the router supports the 5GHz or 6GHz network frequencies, please confirm the router supports the 2.4GHz network frequency band and it is enabled.
- The Wi-Fi dongle is compatible with WPA1, WPA2, and WPA3 security protocols on the 2.4GHz network only.
- Ensure the Wi-Fi dongle can obtain an IP address by verifying the home Wi-Fi router has DHCP (Dynamic Host Configuration Protocol) setup and it is enabled.
- It is recommended the home Wi-Fi network name length does not exceed 19 characters, and the password length does not exceed 24 characters. It is *not* recommended to use any of the following special symbols in the password: @, #, \$, %, &, *, ?, _, /, or using a space “keyboard spacebar”.

View data on smart phone:

A QR code with a link to our website with app installation steps can be found on the side of the inverter. Or visit our downloads page at www.eg4electronics.com for more information.

8.3 ONLINE MONITORING SYSTEM USER INTERFACE



NOTE:

The monitoring system may change due to updates, the following UI descriptions may vary from the current pages on the site. For any questions, or to create distributor or installer accounts, contact support@eg4electronics.com for assistance.

After connecting the Wi-Fi dongle, create an account by registering at monitor.eg4electronics.com. The “customer code” is a code assigned by the distributor or installer. Contact the supplier for this code.

For more information on the Monitoring Center and the settings that can be adjusted there, scan the following QR code:



Monitor Center
Overview

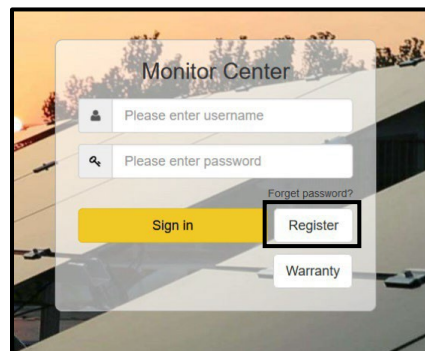

Using the Web interface to set Wi-Fi password.

1. Power on the inverter and connect a mobile phone or laptop to the hotspot after the INV LED on the Wi-Fi module is solid on. The name of the hotspot is the same as the SN on the Wi-Fi dongle shell.
2. Enter 10.10.10.1 in the browser window. The username and password are both "admin" for this dialog box. After logging in, select English on the right side.

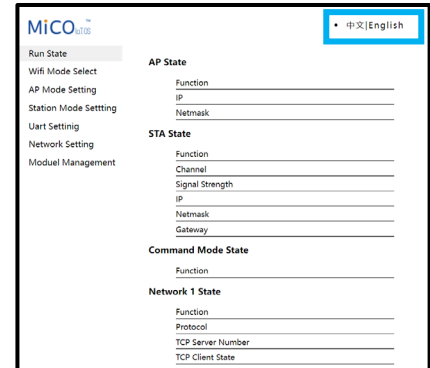
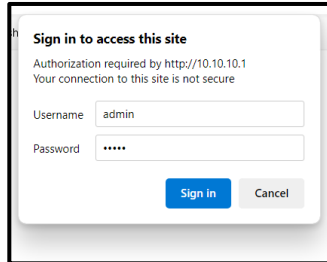
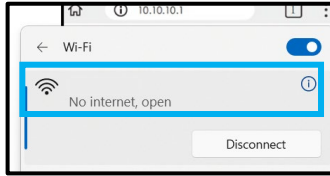

3. Go to the "Station Mode Setting" page. Select "Scan."
4. Choose the desired Wi-Fi network to connect to and select "OK." Input the Wi-Fi password and select "save."
5. After saving the settings, the dongle will restart. After setting the password, three lights will be solid on, which means the inverter is connected to the server.
6. Navigate to the Monitor Center Website (monitor.eg4electronics.com) or the EG4® Monitor App. Input account login and password to begin monitoring the system.

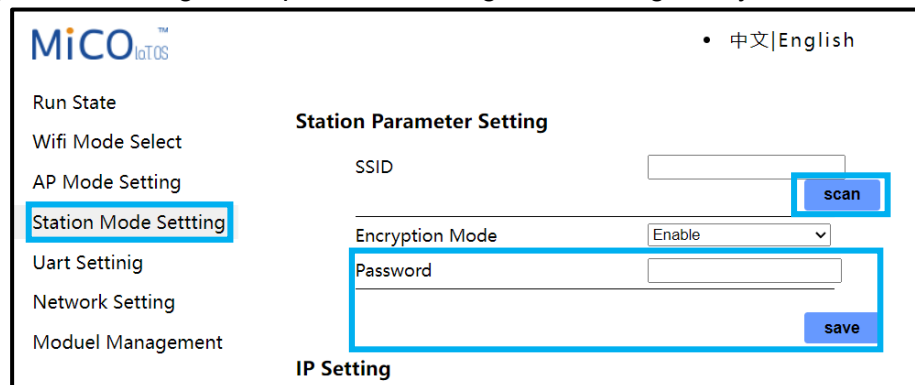

8.4 SMARTPHONE APP SETUP

Register a monitoring account and set the Wi-Fi password for the Wi-Fi dongle *before* using EG4's monitoring system.

1. Register an account:

Visit monitor.eg4electronics.com or download the "EG4® Monitor" app to register for an end-user account. Contact support@eg4electronics.com for distributor or installer accounts.

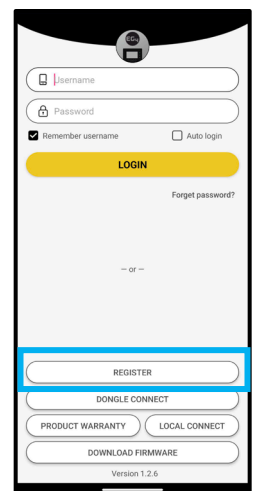

2. **When registering the account, provide the following information:**

- Customer code: Contact the distributor or installer to obtain this code.
- Dongle SN: The serial number is attached to the dongle shell.
- Dongle PIN: PIN is attached to the dongle shell below the SN.

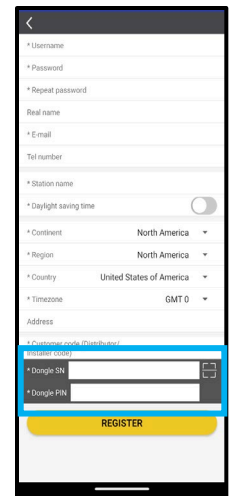

3. **Set the Wi-fi password:**

- Plug in the Wi-Fi dongle, and power on the inverter.
- Wait until the INV LED on the Wi-Fi module is solid on, then connect the mobile device to the Wi-Fi hotspot. The hotspot name is the same as the Wi-Fi dongle serial number.

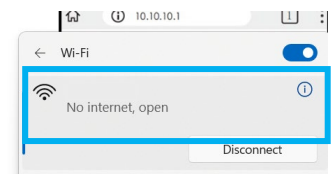

- Open the app. Select "**DONGLE CONNECT**".
- Select the Yellow refresh button to display a list of available networks. Select the wireless network name and enter password.
- After selecting Home Wi-Fi Connect, the Wi-Fi dongle will reset. After the correct password is set, three lights will be solid on, which means the inverter is connected to the server. Return to the login page and input account and password to begin monitoring the system.

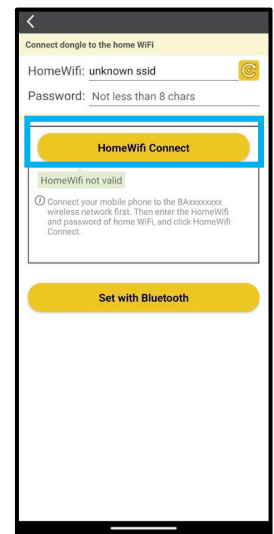
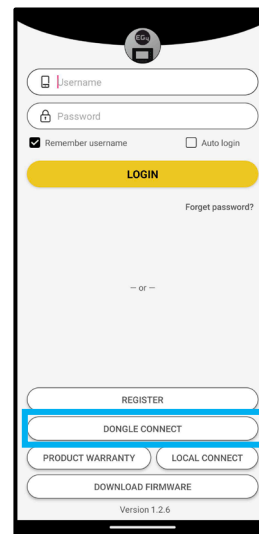

8.5 ENABLE APP NOTIFICATIONS

The EG4® Mobile App allows the end-user to easily check real-time system information regarding the inverters, batteries, and other informative values.

Enable Notifications in Monitor Center:

1. Go to monitor.eg4electronics.com and log in.
2. At the top of the screen, select “Configuration”, then “Users.”

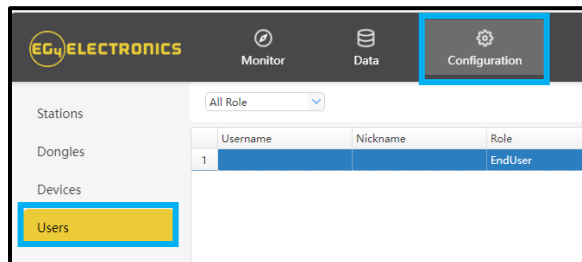

3. Select “User Management”, then “APP Notice.”

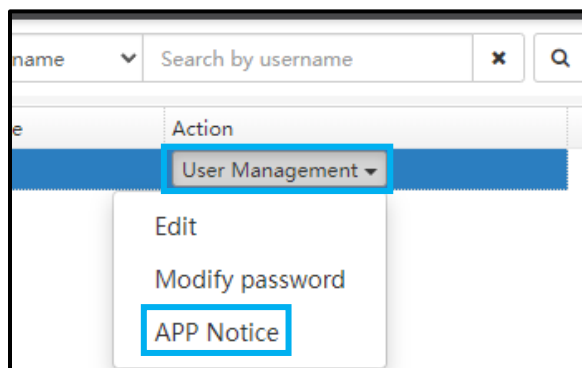

4. Choose which settings to enable, and at what values to be notified. Select “Edit”.

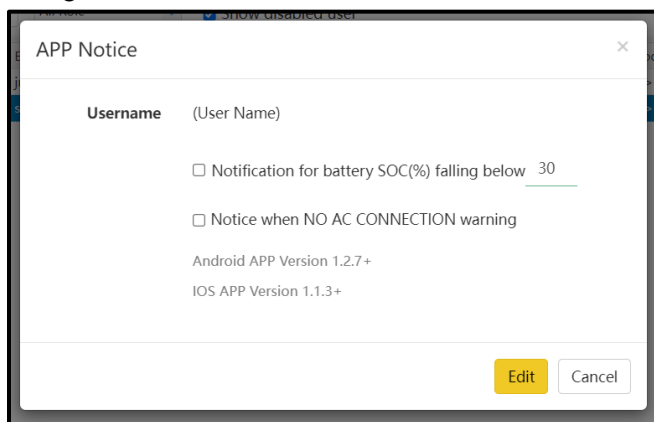

Enable Notifications on a Mobile Device:



NOTE:

Make sure the app is up to date before beginning!

1. Login to the EG4® Monitor App. Select the user icon at the top right corner of the screen.

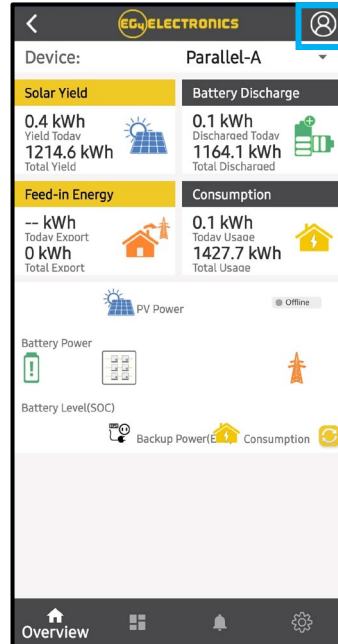
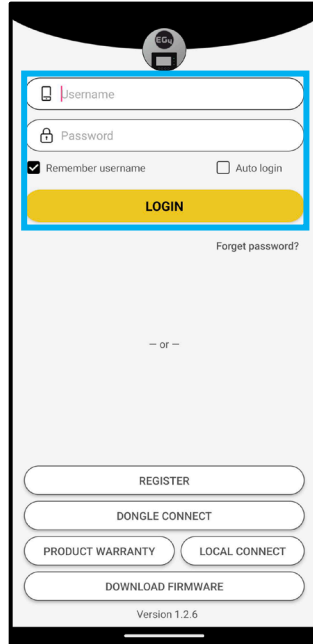

2. Select “Notifications” > “Allow Notifications,” and make selections for which notifications to receive. Toggle selection on to “Allow Notifications” on device and choose how to receive notifications.

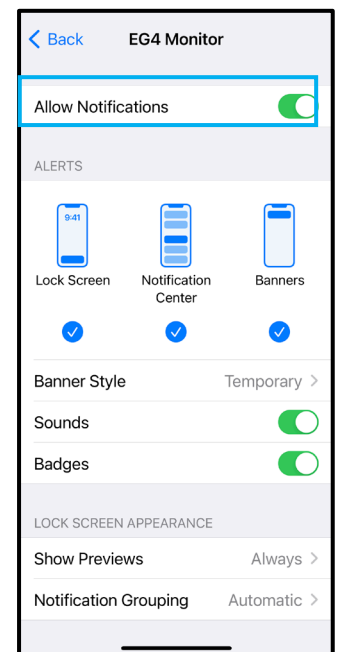
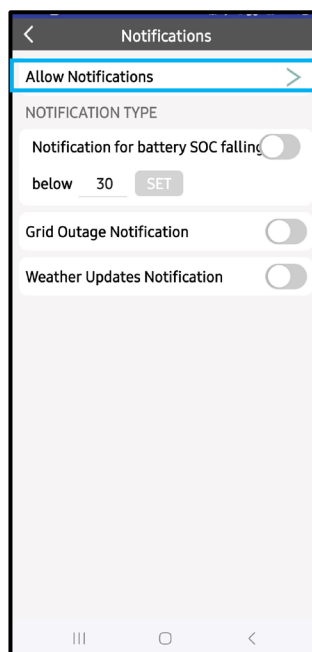
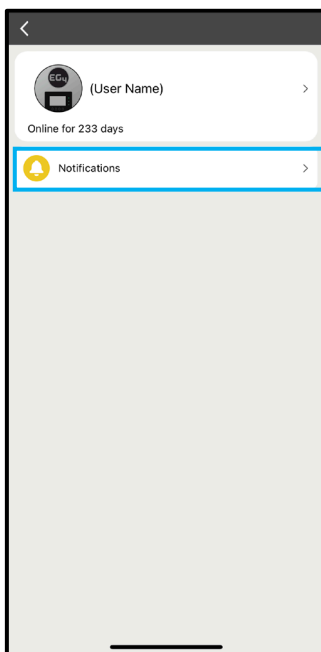

8.6 LOCAL MONITORING SETUP WITH THE EG4® MONITOR APP

If there is no Wi-Fi available at the location, use the local function to monitor or set up the system:

1. Download the EG4 Monitor app.
2. Connect the mobile device to the Wi-Fi hotspot after the INV LED on the Wi-Fi module is solid on. The name of the hotspot is the same as the serial number on the Wi-Fi module shell.
3. Select “Local Connect.” Now the system can be monitored and set up either through Bluetooth or through the hotspot connection.

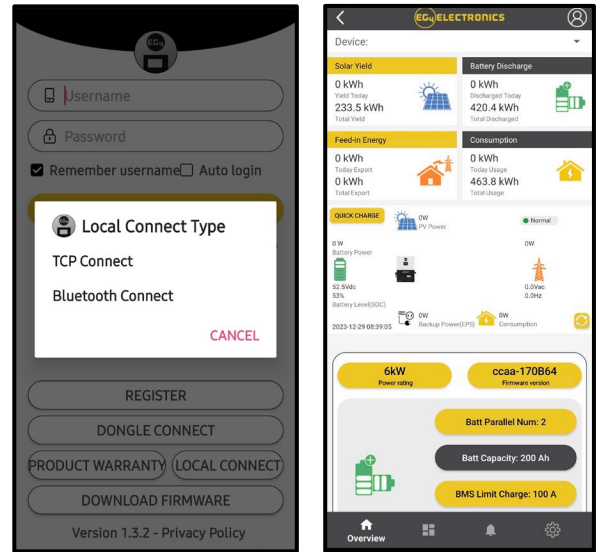

9. OPERATION GUIDE

9.1 INVERTER START-UP AND SHUTDOWN PROCEDURE

Starting up the inverter

1. If equipped, turn on (close) the DC breaker between battery and inverter first. Turn on the BAT breaker located in the cable box of the inverter and then power on the battery system.
2. Make sure the PV voltages of the strings are within operating parameters. Turn on (close) PV isolator switches between the inverter and array and then on the side of the inverter.
3. Make sure Steps 1 and 2 are running properly before turning on the grid power or generator breaker.
4. Power on the load breakers in the cable box of the inverter and then in the load panel.



DANGER:

NEVER disconnect the battery, PV, or AC input power under load. If there is an emergency and users must shut down the inverter, follow the steps outlined below or use the RSD safety feature.

Shutting down the inverter

1. Set the inverter into Standby mode following section 9.2.
2. Turn off the grid breaker feeding the inverter.
3. Switch off the load breaker.
4. Turn off the PV Isolator switch and then battery breaker. Wait for the LCD to go off.

9.2 LCD SCREEN

Running status, real-time power, and daily and accumulated energy information can all be conveniently viewed on the inverter's LCD screen. Additionally, users can check the alarm and fault record on the display for troubleshooting. For more information on the LCD screen, scan the following code:











LCD Menu Map

Viewing Information and Alarm Fault/Record Home Screen

Connect in: xxx S

Touch the LCD screen to light it up when in sleep mode. The home page will appear on the display. Users will see a system overview diagram along with real-time information of each component such as battery SOC, battery charging/discharging power, grid import/export power, load power, etc. On the right side of the screen, users can check daily and accumulated solar energy, battery charge/discharge energy, grid import/export energy, as well as load consumption.

PV Energy
Today: 
Total: 
Charge Energy
Today: 
Total: 
Export
Today: 
Total: 
Consumption
Today: 
Total: 

LCD Version :

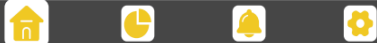

Setting Parameters

Select the gear icon at the bottom of the screen to get into the parameter setting page for the inverter. If prompted during setting changes, enter “00000” as the password.

1. Basic Settings:

- “Standby”: This setting is to set the inverter to normal or standby status. In standby status, the inverter will stop any charging, discharging, or solar feed-in operations.
- “Restart Inverter”: This selection restarts the system.
Note: power may be interrupted when the unit is restarted.

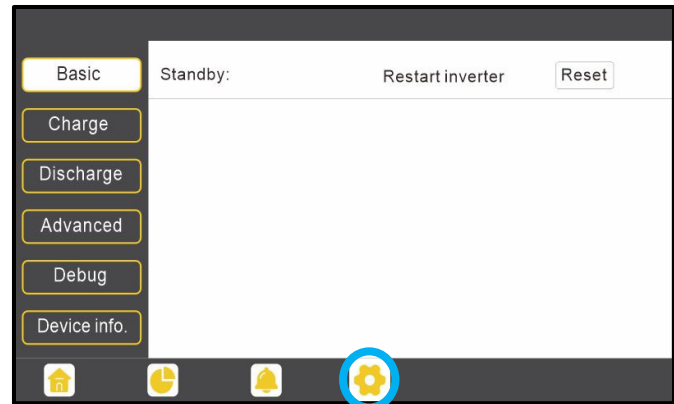

2. Charge Settings:

- “Operating Mode”: Users can decide to use state of charge (SOC) or battery voltage (Bat V) to control charge and discharge logic depending on battery type.
- “Bat. charge current limit (A)”: Set the maximum charge current.
- “AC Charge”: Grid charge configuration. To use grid power to charge the battery bank, enable “AC Charge” and set up to three different time periods when AC charging can happen.
 - Set “AC charge power (kW)” to limit grid charging power.
 - Set “Stop AC Charge SOC (%)” as the target SOC for grid charging.
 - Set “Stop AC charge Volt (V)” as the target battery voltage for grid charging

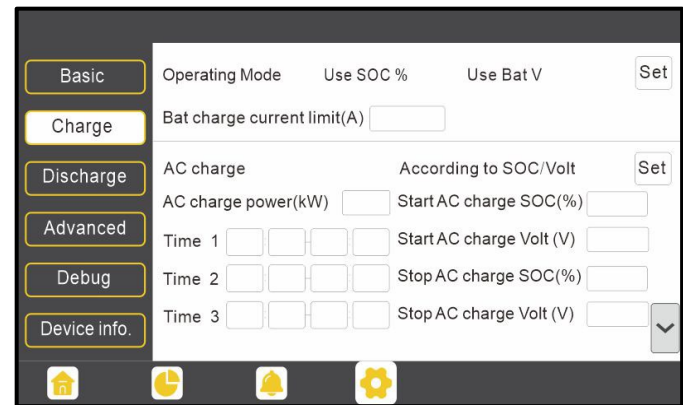

- “Charge first (PV)”: PV charge configuration. PV will charge the battery bank first. Set up to three different time periods when PV charge can happen.
- “PV Charge Priority power (kW)”: Limits PV charge power.
- “Stop PV Charge Priority SOC(%)”: The target SOC for PV Charge Priority.
- “Stop PV Charge Priority Volt(V)”: The target battery voltage for PV Charge Priority.
- “Lead-Acid”: When using a lead-acid battery, set parameters in these programs. Follow the battery manufacturer’s recommendation for these settings.

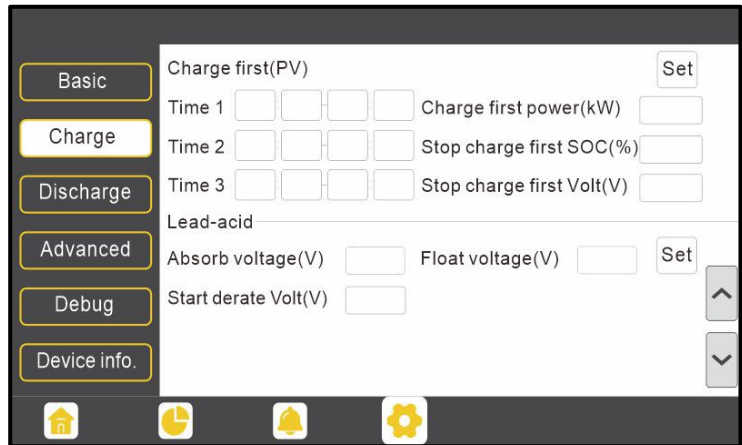

3. Discharge Setting

- “Operating Mode”: Users can choose “Use SOC%” or “Use Bat V” to control the battery discharge state.
- “Discharge current limit(A)”: The maximum discharge current from the battery.
- “Discharge start power(W)”: The minimum value can be set to 50. When the inverter detects the import power is higher than this value, the battery starts discharging; otherwise, the battery will stay in standby.
- “On-grid Cut-off (%), Off-grid Cut-off (%) / On-Grid Cut-off(V), Off-grid Cut-off (V)”: Choose when to stop discharging the battery bank when on or off-grid based on SOC or voltage*.
- “Forced discharge”: This setting will force the battery to discharge within the programmed period. In the preset period, the inverter will discharge the battery at the power set by “Discharge power (kW)” until battery SOC or voltage reaches “Stop discharge” value.

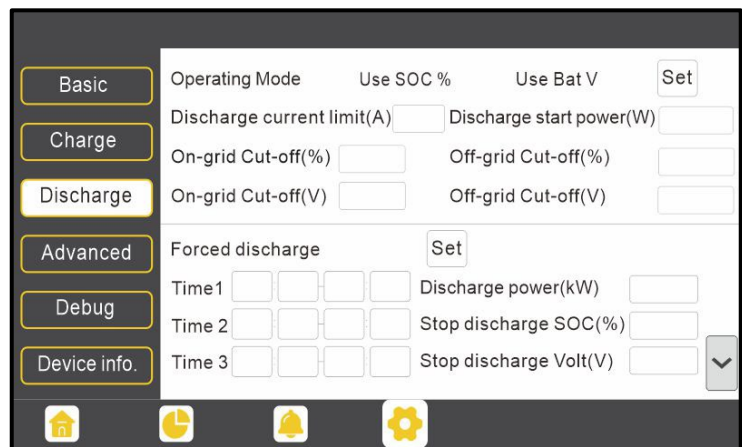

NOTE:

*When using EG4® batteries with the 18kPV inverter, it is recommended to set the cut-off SOC to 20% to maintain the 80% Depth of Discharge (DOD).

- “Grid peak-shaving”: Peak-shaving is used to avoid peak demand charges from the grid. Peak-shaving can be accomplished by halting grid charging at specific time.
- “Grid peak-shaving Power(kW)”: The maximum power the inverter can draw from the grid.
- “Grid peak-shaving Start SOC/Volt”: The voltage or SOC at which grid peak-shaving will start.

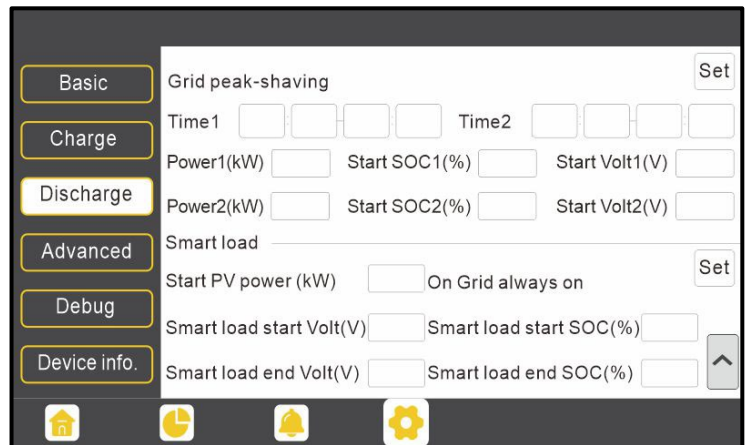

4. Generator:

- “Bat. charge current limit(A)”: Maximum battery charge current from the generator. The generator will start charging according to the “Charge start Volt/SOC” and stop charging when the battery voltage or SOC reaches the “Charge end Volt/SOC” value.
- “Gen rated power(kW)”: The inverter has a peak-shaving function. Enable and set up gen peak-shaving power with this setting.

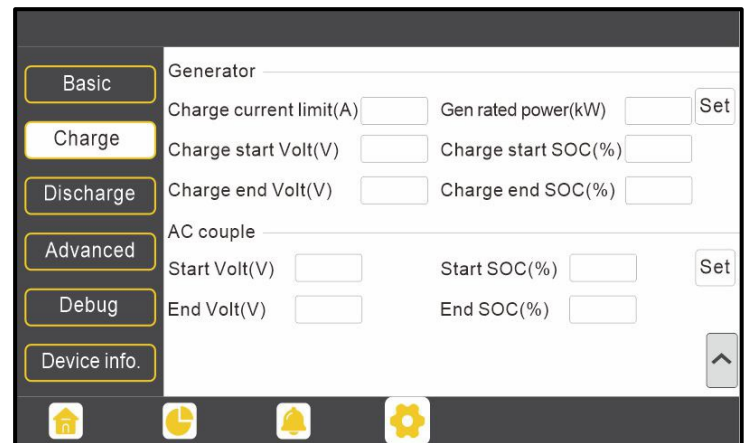



IMPORTANT:

The following settings may need to be adjusted by the installer after installation. Consult with the installer/ distributor before making any changes to avoid conflicting settings or damage the system!

5. Advanced Settings:

- “Grid type”: Choose 240/120V or 220/208
- “Grid Regulation”: Select the correct grid safety regulation.
- “Grid Frequency”: If the Grid Frequency is nominal at 50Hz, then the inverter’s frequency will be adjusted to 50Hz automatically. If there is no grid power, and frequency is read as 50Hz, but the devices are 60Hz, set to 60Hz manually. This is based on the rated frequency of the local grid regulation and devices.
- “Battery type”: Select “No battery”, “Lead-acid”, or “Lithium”.
 - If “Lead-acid” battery is selected, input the correct battery capacity.
 - If “Lithium” battery is selected, choose the battery’s brand in the Lithium brand drop-down list.
- “Off-grid output”: enabling this setting will cause the inverter to provide backup power if the grid is lost.
- “Seamless switch”: must be enabled to transfer the load seamlessly to the inverter backup power.
- “No Battery”: enable to use solar power to supply load when the grid fails, or load-shedding happens. If users do not have a battery bank installed yet, but still wish to have inverter backup power with only solar panels connected, this setting can be enabled.
- “Micro-grid”: only set when a generator is connected to the inverter’s GRID terminal. With this option enabled, the inverter will use AC power to charge the battery bank and will not export any power through the GRID terminal if AC power is present.
- “Charge last”: uses solar power in the following order: 1. Loads > 2. Grid export > 3. Battery charging. *Note: Grid Export limits must be set through grid peak-shaving settings under Discharge Settings.*
- “CT direction reversed”: occurs when both CTs are installed in the wrong direction; the installer can remedy this by checking this box.



NOTE:

Zero Export cannot prevent export of energy supplied by inverters that are AC coupled to the 18kPV

- “Export to Grid”: This selection is to set a zero-export function. If exporting solar power is not allowed, disable the “Export to Grid” option. If a user’s grid meter is tripped with minimal solar export, “Zero Export” can be enabled, thus, the export detection and adjustment will take place every 20ms, which will effectively avoid any solar power being exported. If export is allowed, users can enable “Export to Grid” and set a maximum allowable export limit in “Max Export to Grid(kW).”
- “Role”: In a parallel system, only one inverter is allowed to be set as Master and the others are set as Slaves. Inverter is set to “1 phase master” by default
- “Phase”: The phase code setting of the load output. The system will automatically detect the phase sequence of the inverter (consistent with the phase sequence of the connected grid mains) and display it on the inverter after it is connected to the grid.
- “Share battery”: If all inverters are connected to the same battery bank when configured as a parallel system, this setting must be enabled. If the inverters are configured as a parallel system, and are connected to independent battery banks, this setting must be disabled.

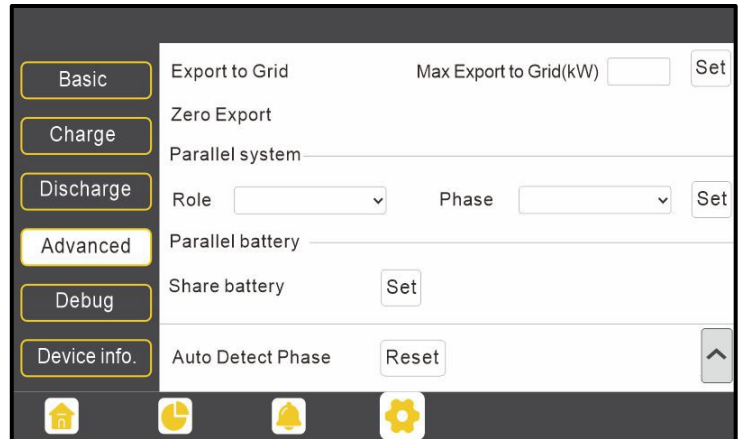

REMINDER:

- All setting changes for parallel inverters must be done while in standby mode.
- If the system is connected to a lithium battery, the host of the battery bank needs to communicate with the inverter that is set as Master in the parallel system.
- Keep all setting the same for each inverter in the parallel system on the LCD screen or remote monitor center.

6. Debug

Frequently asked questions for simple troubleshooting issues. Touch each question to see the answers for each question. If an issue is not addressed on this page, contact the distributor.

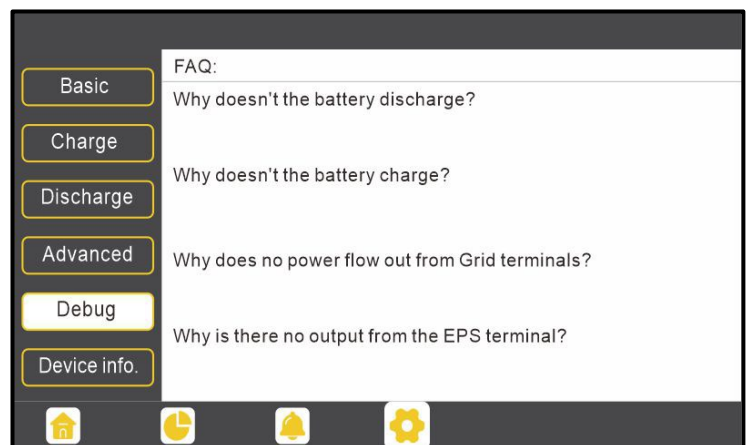

7. Device Info.

- “Time”: the format for inputting the time is the four-digit year, two-digit month, two-digit day. Followed the two-digit hour, two-digit minute, and two-digit second (in 24-hour format.)
- “Backlight time(S)”: how long the backlight will stay lit.
- “Inverter information”: this information is not editable. It will update as the inverter is updated. For more information on how to update the inverter, see section 10.

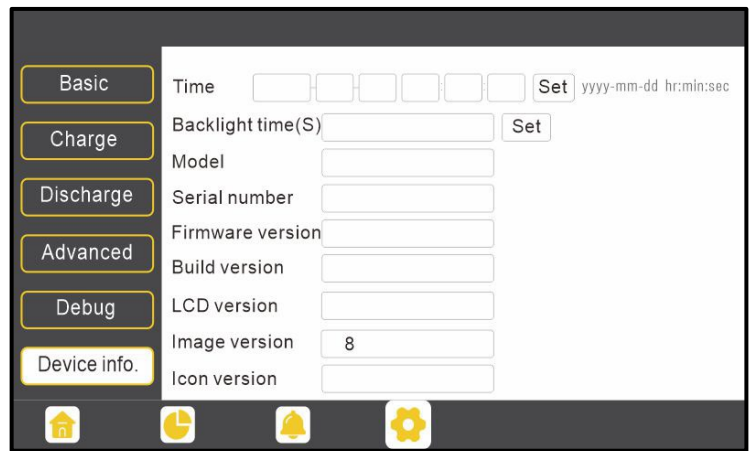

For more information on LCD settings, scan the following code:



LCD Menu Map

9.3 WORKING MODES AND RELATED SETTINGS

Time of Use:

Time of use is a setting that is applicable to numerous scenarios to maximize cost savings by adjusting the battery’s usage patterns. It enables the system to meet energy demands across different time periods, provide real-time system status, and provide detailed reports. This feature is customizable for fluctuations in electricity prices and to individual needs.

To enable this feature, select “Maintenance” at the top of the Monitor Center Webpage. Select “Weather Optimization” to the left of the screen. Select the desired inverter and select the location button. Input the inverter’s information on the next screen. Afterwards, enable the times of use for battery charging/discharging under the “Maintenance” tab.

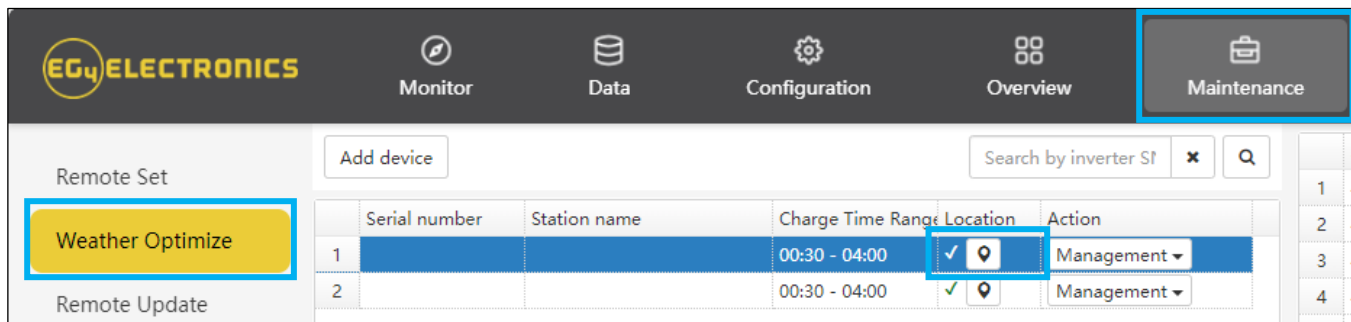

Weather Optimize Function:

Used to collect real-time weather data to automatically adjust the state of charge. This maximizes the efficient use of solar energy by ensuring the battery bank remains adequately charged for stable electricity consumption. “Charge Priority Mode” prioritizes battery charging to ensure stable electricity usage, making it ideal for areas with unstable power supply. “Self-Consumption Mode” prioritizes self-generated solar power to meet household electricity demands, making it ideal for areas with high electricity prices. “Forced Charge/Discharge Mode” chooses to charge or discharge batteries based on electricity pricing, making it ideal for time-of-use pricing areas.

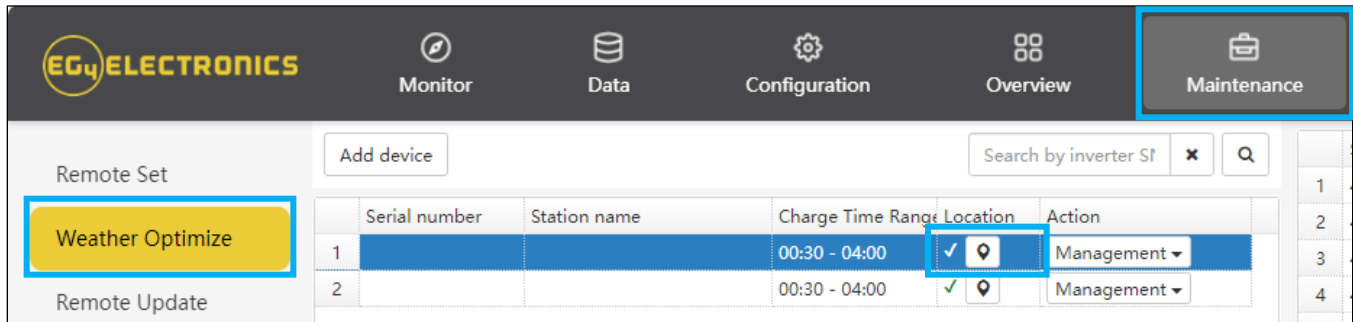

- To enable this feature, select “Maintenance” at the top of the Monitor Center Webpage. Select “Weather Optimization” to the left of the screen. Select the desired inverter and select the location button.

The screenshot shows a form for setting station information. Fields include: Station name (with a checkmark), LNG-LAT (with a location icon), Create time, Continent (North America), Region (North America), Country (United States of America), and Timezone (GMT -6). There are radio buttons for Daylight saving time (Yes/No) and buttons for Update, Export, and Cancel.

- Input the inverter’s information and select “Update”.

- Afterwards, select “Management” and click “Edit”. Here, users can set charging times and percentages based on their electricity use patterns and weather conditions. The platform sends user settings to the inverter, and the inverter provides feedback, confirming the receipt of setting and executing charging operations according to user-defined parameters.

The screenshot shows a form for setting charging parameters. Fields include: Serial number, Charge Start Time (00:00), Charge End Time (00:00), and a section for 'Charge percent(%) by weather'. This section has input fields for: Clear sky, Few(11%-25%) clouds, Scattered(25%-50%) clouds, Broken(51%-84%) clouds, Overcast(85%-100%) clouds, Light rain, Moderate rain, Heavy rain, and Other. There are 'Edit' and 'Cancel' buttons at the bottom.

Working Modes:

Working modes are pre-set priority systems that allow users to configure the system to meet their demands through extensive customizations. These modes can be found under the Maintenance tab by selecting “Working Mode.” Scroll past “Application Setting” to the “Working Mode Setting” section.



Working Mode Definitions:

- **Backup Mode:** Used to save battery power as a last resort. The solar arrays power the loads, and when PV is insufficient, loads will pull from the grid. The inverter will only power loads with battery when there are no other options.
- **Peak Shaving:** Used to avoid peak demand charges from the grid by using a combination of settings to limit the power drawn from the grid.
- **AC Charge Mode:** Used to charge battery bank with the grid while loads are supported by PV. Batteries can then be used when electricity prices are high.
- **PV Charge Priority:** Used to charge battery bank with PV; once battery bank is charged, then PV will be used to power loads.
- **Forced Discharge/Export PV Only:** Used to sell PV and/or battery power back to the grid.
- **Self-Consumption:** Used to significantly lower grid consumption. Solar arrays power loads, then, when PV is insufficient, batteries power loads, and AC is only used as a last resort.

Backup Mode

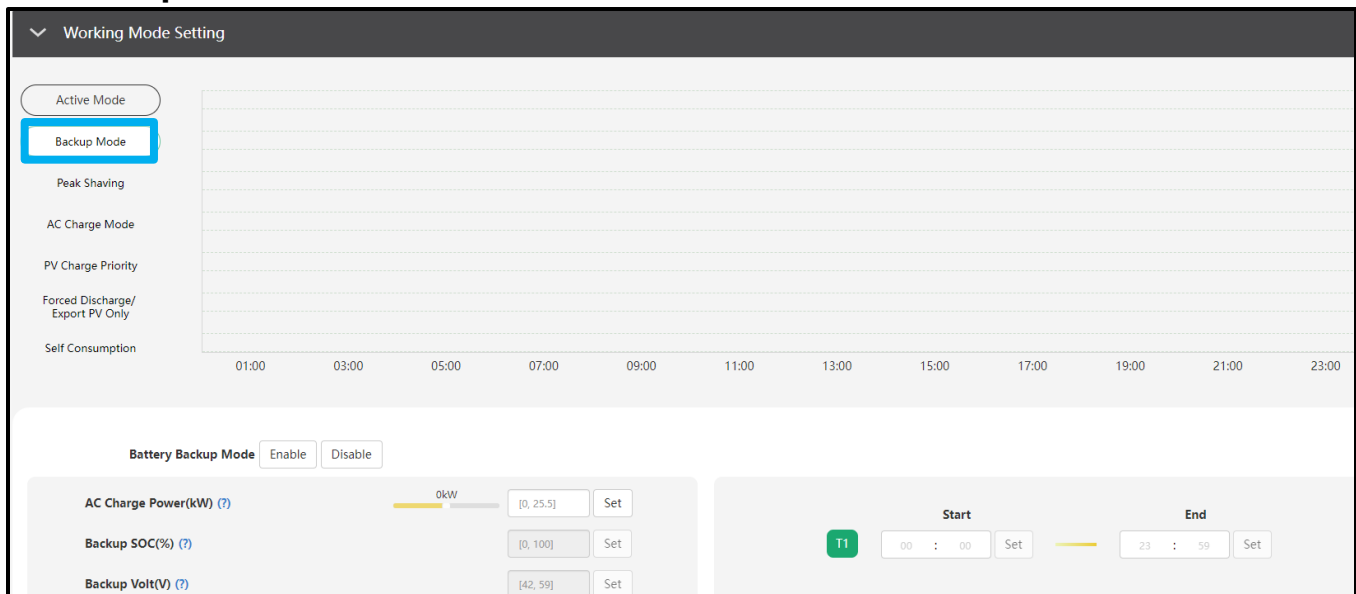

When setting the station in this mode, the inverter will use batteries as a last resort. The user will be able to configure the system to set how much power is drawn from the grid; at what percentage, voltage, and time to stop and start charging.

Upon selecting the working mode, the system must be configured using the settings listed below:

- **Battery Backup Mode:** “Enable” “Battery Backup Mode”.
- **AC Charge Power(kW):** Set the maximum amount of power to draw from the grid.
- **Backup SOC (%) / Volt (V):** Percentage or voltage at which the system will stop charging batteries from the grid.
- **T1 Start/ T1 End:** Set the start and end time of charging.

Peak Shaving:

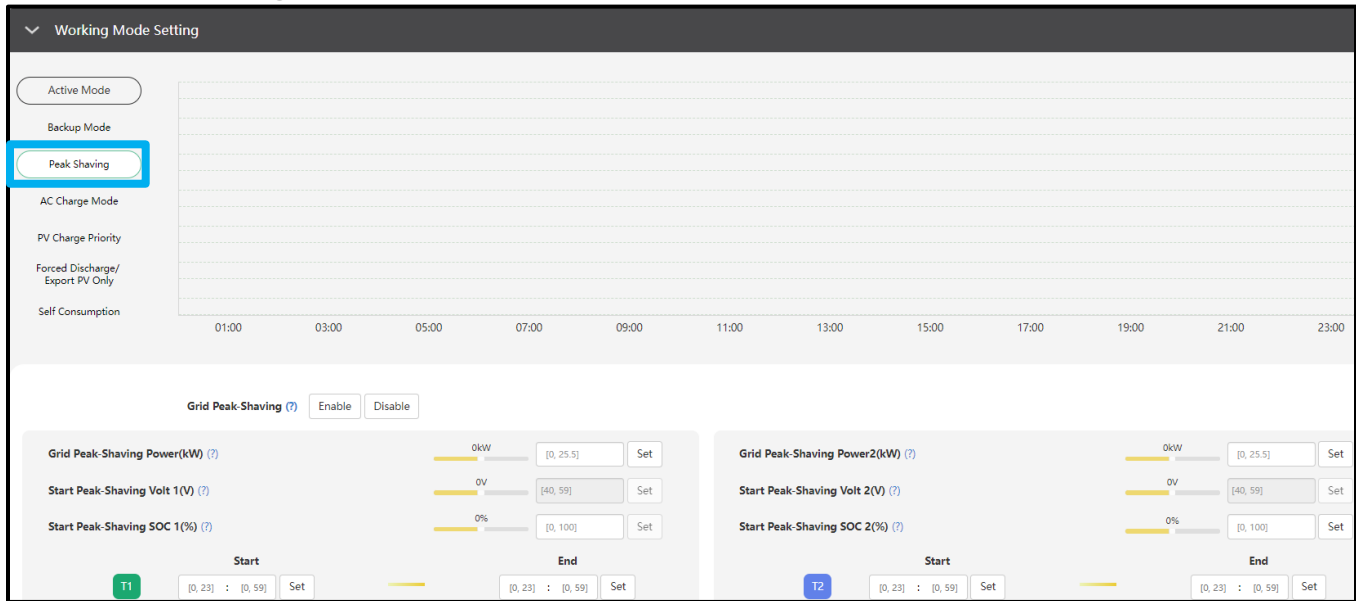

When setting the station into this mode, the inverter will use peak-shaving to avoid peak demand charges from the grid. The user will be able to configure the system to pull limited (or no) power from the grid by setting maximum power pulled from the grid, the SOC/voltage of the battery bank in which to start grid peak-shaving, and by setting time of use.

Upon selecting the working mode, the system must be configured using the settings listed below:

- **Grid Peak-Shaving:** “Enable” “Grid Peak-Shaving”.
- **Grid Peak-Shaving Power(kW)/Grid Peak-Shaving Power2(kW):** Set the maximum amount of power that will be drawn from the grid.
- **Start Peak-Shaving Volt 1(V)/Start Peak-Shaving Volt 2(V):** Set the starting point of peak-shaving when using voltage setpoints for batteries.
- **Start Peak-Shaving SOC 1(%) / Start Peak-Shaving SOC 2(%):** Set the starting point of peak-shaving when using SOC setpoints for batteries.
- **T1/T2 Start:** Set the start time of peak-shaving depending on SOC/voltage as configured above.
- **T1/T2 End:** Set the end time of peak-shaving depending on SOC/voltage as configured above.

AC Charge Mode:

The screenshot displays the 'Working Mode Setting' interface. The 'AC Charge Mode' option is highlighted in the left-hand menu. The main area contains a large empty grid for monitoring. Below the grid, the 'AC Charge Enable' toggle is set to 'Enable'. The configuration section includes several settings: 'AC Charge Power(kW)' is set to 25.5; 'AC Charge Based On' is set to '<Empty>'; 'Start AC Charge SOC(%)' is set to 42.59; 'Stop AC Charge SOC(%)' is set to 100; 'Start AC Charge Volt(V)' is set to 40.57; and 'Stop AC Charge Volt(V)' is set to 42.59. On the right side, there are three time periods (T1, T2, T3) with 'Start' and 'End' time settings.

Users can charge battery bank with grid power when electricity prices are low, then use battery power to run loads or export to the grid when electricity prices are high. When setting the station into Backup/AC Charge mode, the user can configure the system to prioritize charging batteries from grid power. The user can configure the settings to charge with grid based on maximum power in kW, SOC/voltage, or by setting times of use.

Upon selecting the working mode, the system must be configured using the settings listed below:

- **AC Charge Enable:** “Enable” the system’s ability to charge batteries from the grid.
- **AC Charge Power(kW):** Set the maximum power drawn from the grid to charge batteries.
- **AC Charge Based On (SOC/Volt/Time):** Configure how the system will charge batteries from the grid by setting custom voltage points, SOC% of batteries, or by time.
- **Start/Stop AC charge SOC (%) / Volt (V):** Percentage or voltage at which the system will start and stop charging batteries from the Grid.
- **T1/T2/T3 Start and End:** The time periods in which the system can charge the battery bank.

PV Charge Priority:

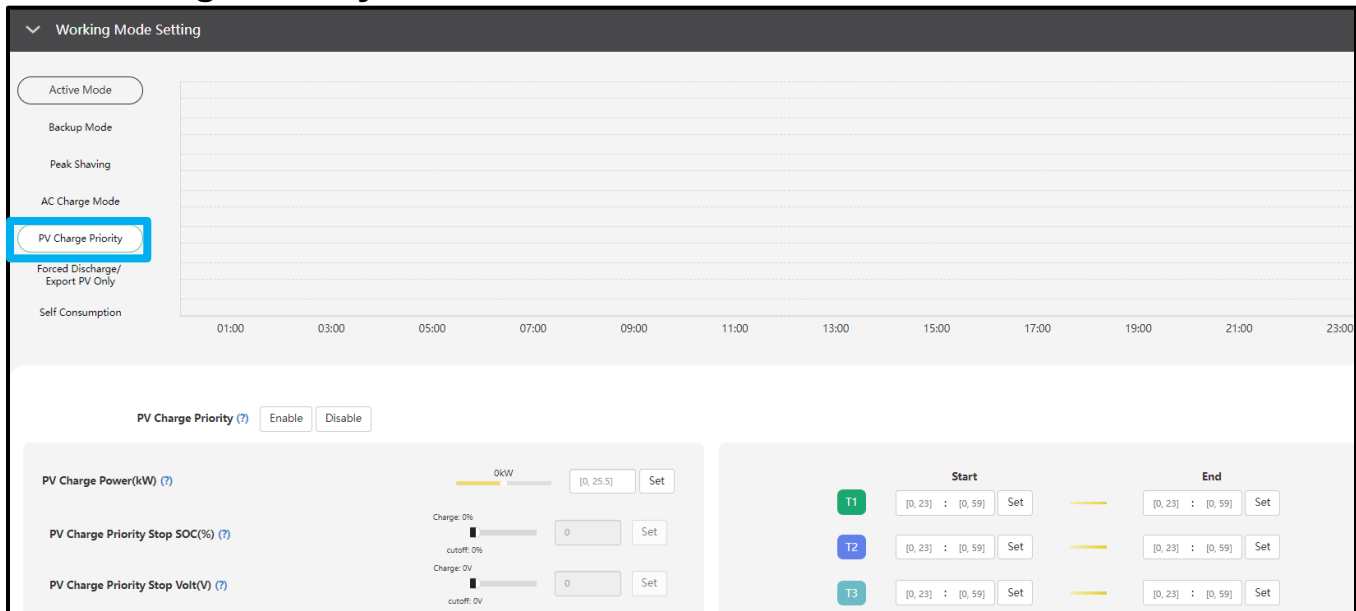

The order of priority for solar power usage will be Battery >Load >Grid. During the “PV Charge Priority” period, loads are first supplied power from the grid. If there is excess solar power after charging batteries, the excess solar will power the loads along with grid power.

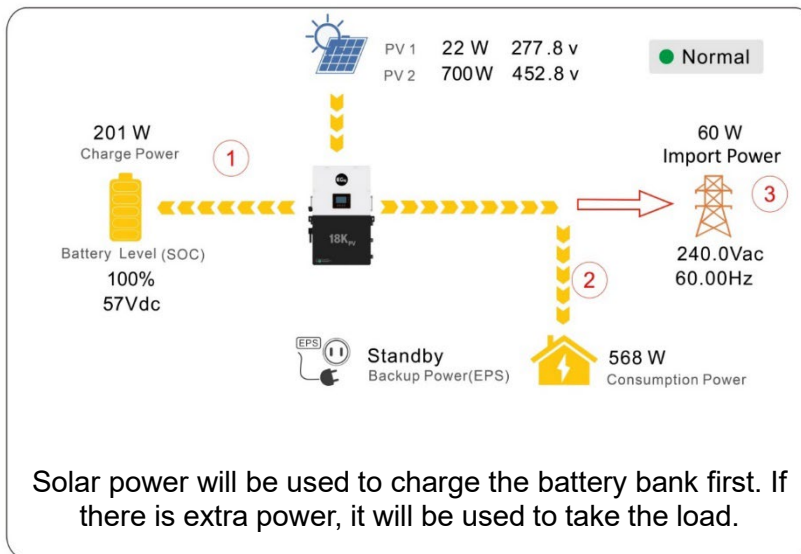

Upon selecting the working mode, the system must be configured using the settings listed below:

- **PV Charge Priority:** “Enable” “PV Charge Priority” working mode.
- **PV Charge Power(kW):** Set the maximum amount of power to charge the batteries from solar.
- **PV Charge Priority Stop SOC (%):** Set the stop point for “Battery Priority” according to SOC%.
- **T1/T2/T3:** Set up to 3 different start and stop times for the PV Charge Priority working mode.

Forced Discharge/Export PV Only:

The screenshot displays the 'Working Mode Setting' interface. On the left, a sidebar lists various modes: Active Mode, Backup Mode, Peak Shaving, AC Charge Mode, PV Charge Priority, **Forced Discharge/Export PV Only** (highlighted), and Self Consumption. The main area shows a time-based graph for 'Self Consumption' with a horizontal axis from 01:00 to 23:00. Below the graph, the configuration for the selected mode is shown:

- Forced Discharge Enable**: Enable/Disable buttons.
- Export PV Only**: Enable/Disable buttons.
- Forced Discharge Power(kW)**: Input field [0, 25.5] and Set button.
- Stop Discharge SOC(%)**: Input field [0, 100] and Set button.
- Stop Discharge Volt(V)**: Input field [40, 56] and Set button.
- Time Periods (T1, T2, T3)**: A table with columns for Start and End times, each with input fields and Set buttons.

When setting the station into this mode, the batteries will be forced to discharge within the set periods of time. During this period, the inverter will discharge the battery at the power set by “Forced Discharge Power(kW)” until the battery SOC or voltage set point reaches the “Stop Discharge” value.

Note: EG4® suggests setting this value no lower than 20% to maintain the recommended 80% Depth of Discharge (DOD).

Upon selecting the working mode, the system must be configured using the settings listed below:

- **Forced Discharge Enable:** “Enable” this setting to forcefully discharge the station’s battery bank.
- **Export PV Only:** “Enable” this setting to sell back generated PV power to the grid.
- **Forced Discharge Power(kW):** Set the maximum power limit of battery discharge.
- **Stop Discharge SOC (%):** Stop the forced discharge upon reaching the set SOC%.
- **Stop Discharge Volt(V):** Stop the forced discharge upon reaching the set voltage point.
- **T1/T2/T3:** Set up to 3 different start and stop times for the Force Discharge/Sell to Grid working mode.

Self-Consumption:

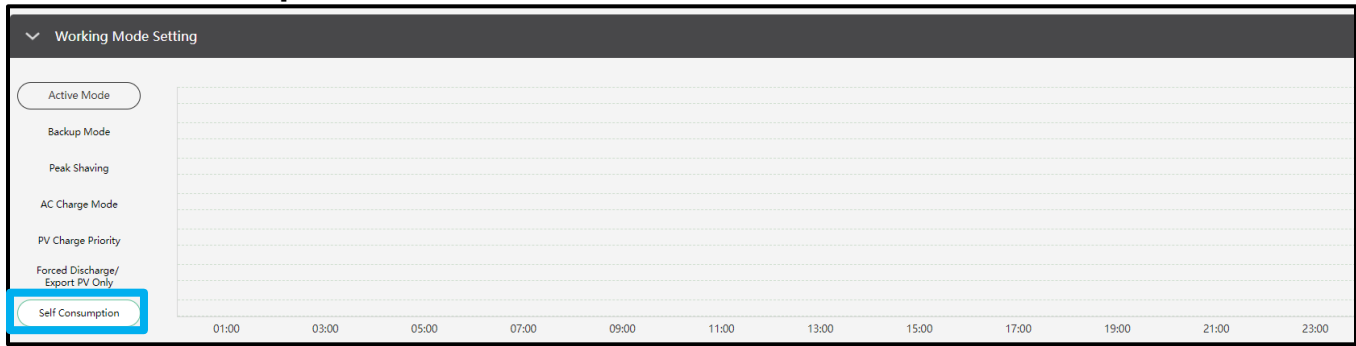

The station will default to Self-Consumption mode. The order of priority for powering loads is Solar > Battery > Grid. The order priority for solar power is Load > Battery > Grid which creates an ideal scenario when needing to prioritize solar power generation over other types of power. Self-Consumption mode will increase the self-consumption rate of solar power and reduce energy bills significantly. Effective when Charge Priority, AC Charge, and Forced Discharge are disabled.

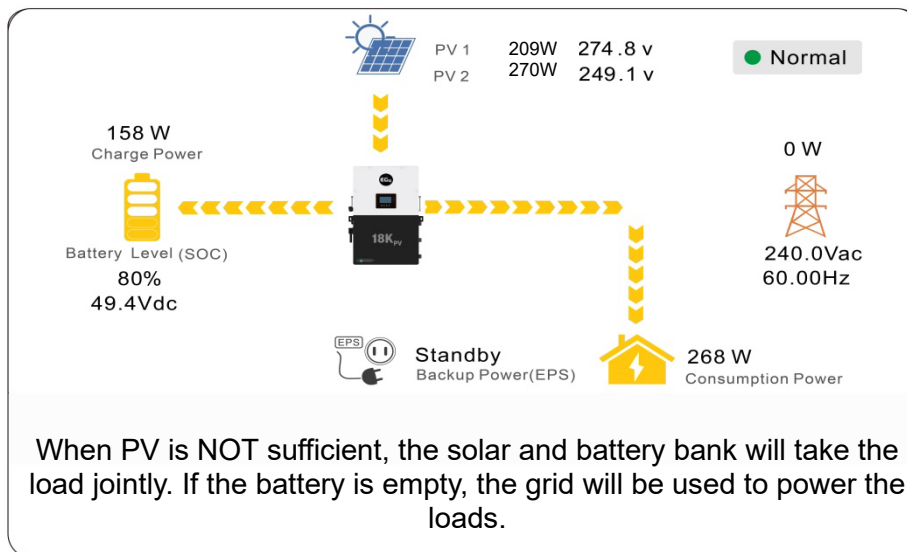
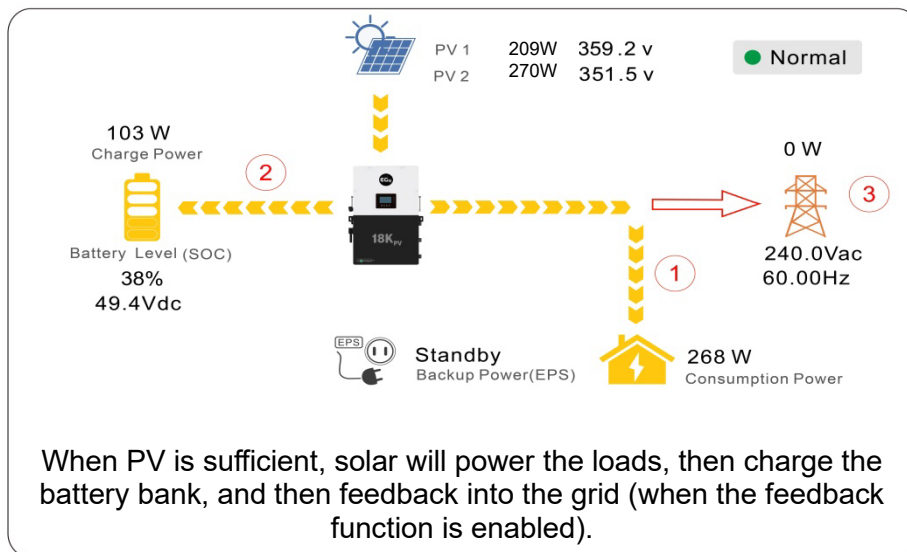

9.4 RAPID SHUTDOWN (RSD)

The inverter includes a rapid shutdown system that complies with 2017 and 2020 NEC 690.12 requirements. A rapid shutdown switch should be connected to the RSD terminals on the inverter and mounted on a readily accessible location outdoors (check with the local AHJ for requirements).



NOTE:

When using supported EG4® batteries in closed-loop communications with the inverter, the RSD also initiates ESS Disconnect as required by NEC code.

External RSD

The system can also utilize an External E-Stop Switch if the local AHJ deems it necessary.

The external switch must be “Normally Open” by default, and “Closed” when the button is pressed for emergency shutdown.

If utilizing an external E-Stop switch, see the following subsection for instructions.

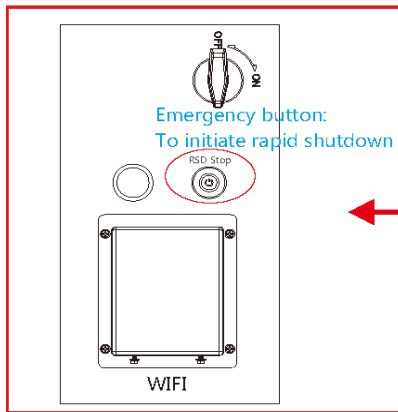
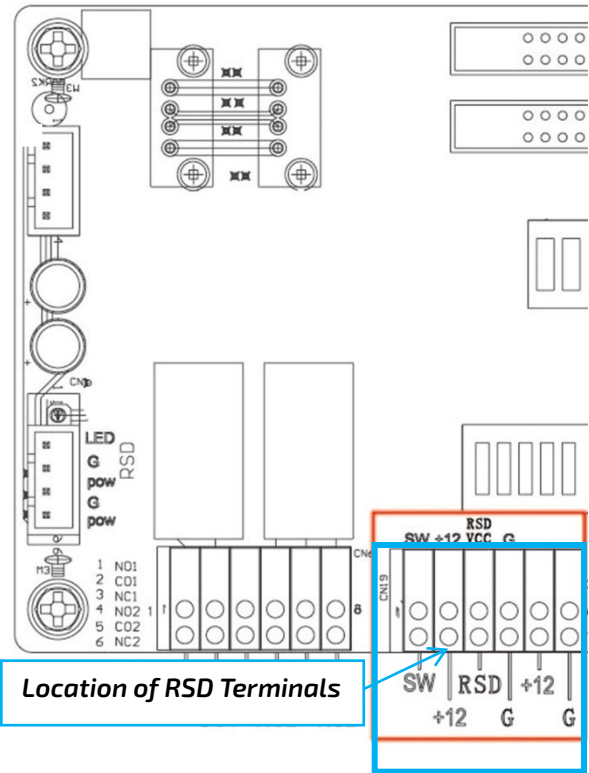

RSD Transmitter

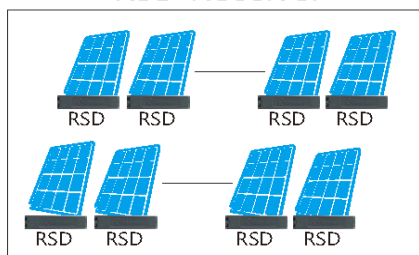
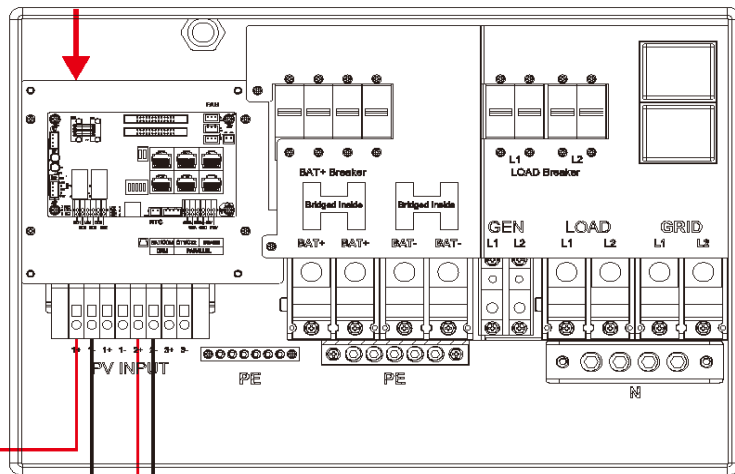

In case of emergency, press the rapid shutdown button to cut off the RSD power supply, in turn cutting the inverter's AC Output along with dropping the PV Conductors voltage to <30V in 30 seconds.

External RSD Wiring Instructions



NOTE:

If the inverter does not have the RSD terminals located in the image, contact the distributor for information regarding the steps for RSD installation.

Wire the E-Stop Switch into the RSD terminals according to the switch's specifications.

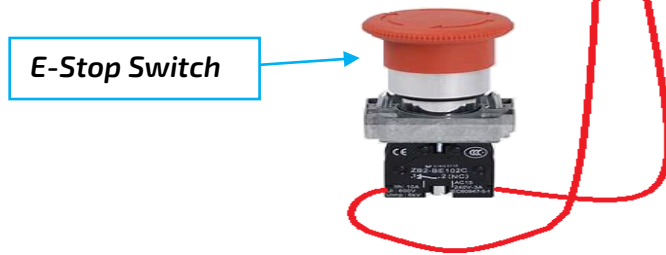
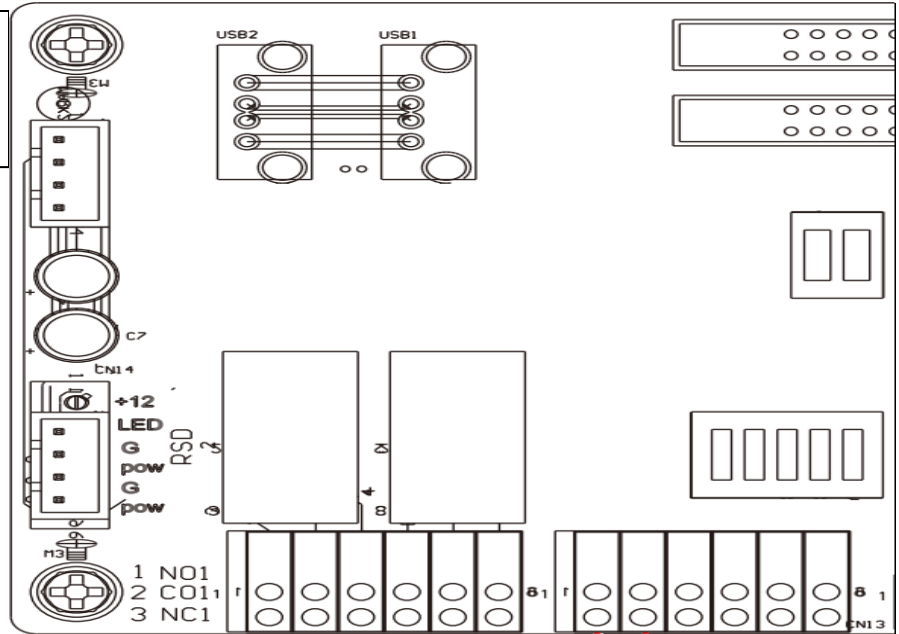

For more information on Rapid Shut Down, see the following link.



Rapid Shut Down
Wiring Guide

10. POWER CONTROL SYSTEM

10.1 EXPORT LIMITING FROM ALL SOURCES (PEL)

- A. **Export to Grid:** Enables power export to the grid.
- B. **Max export to Grid (kW):** Sets the maximum allowable power export to the grid setting.
 - a. **Note:** To allow power export from the inverter to the grid, "Export to Grid" must be enabled, and "Max Export to Grid" must be set to a value greater than 0. This value defines the upper limit of export power.
- C. **Zero Export:** Disables all power export to the grid.

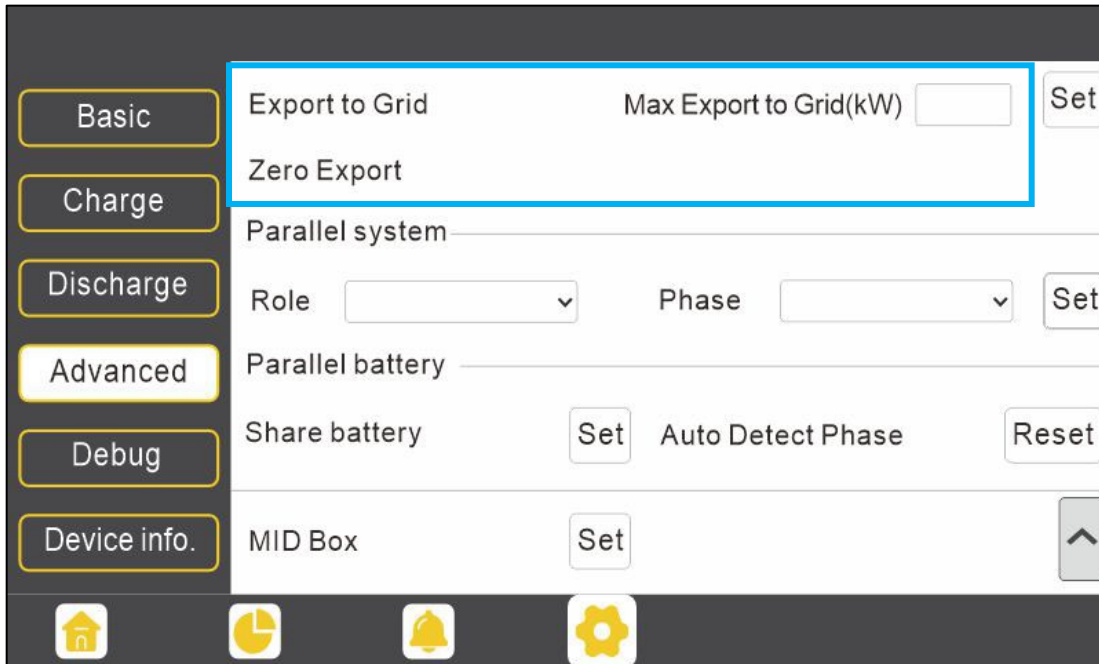

- D. **Discharge current limit (A):** Defines the maximum discharge current allowed from the battery.

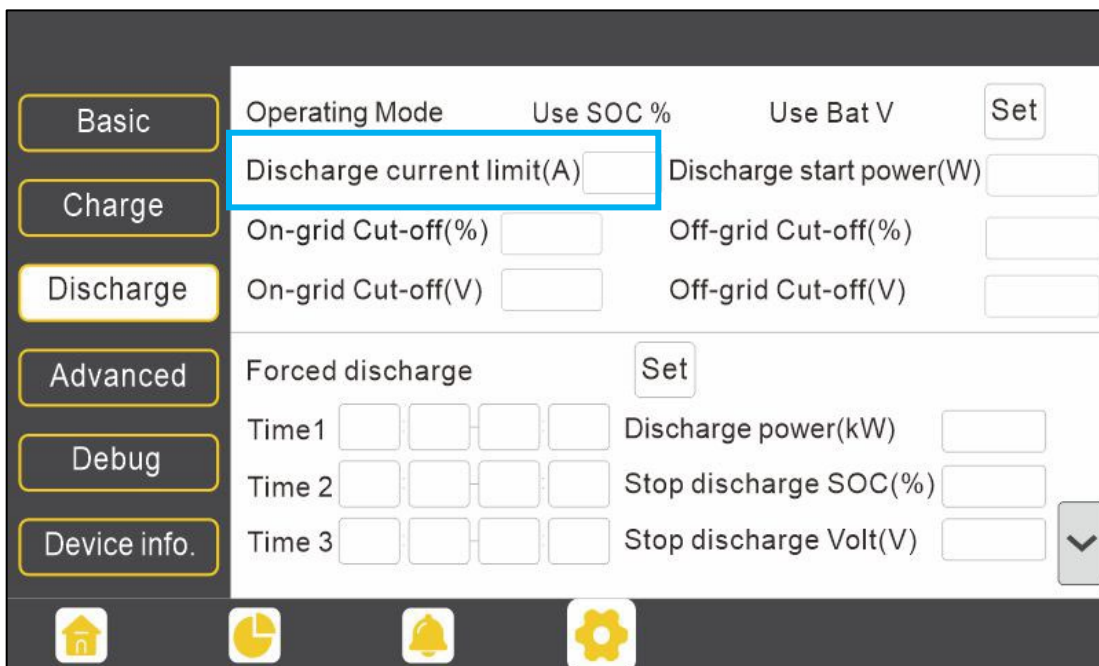

- E. **Discharge power (kW):** Sets the maximum power the battery can deliver when the *Forced Discharge* function is enabled.

The screenshot shows the EG4 battery management system interface. On the left, there is a vertical menu with buttons for 'Basic', 'Charge', 'Discharge', 'Advanced', 'Debug', and 'Device info.'. The 'Discharge' button is highlighted. The main area displays various settings for the battery system. Under the 'Discharge' section, the 'Forced discharge' option is checked, and the 'Discharge power(kW)' field is highlighted with a blue box. Other settings include 'Discharge current limit(A)', 'Discharge start power(W)', 'On-grid Cut-off(%)', 'Off-grid Cut-off(%)', 'On-grid Cut-off(V)', and 'Off-grid Cut-off(V)'. At the bottom, there is a navigation bar with icons for home, battery status, notifications, and settings.

Prerequisite: Export to Grid is Enabled.

For example: Max Export to Grid is 5kW.

- If the system has battery power but there is no PV coming in (perhaps because the sun is down, or because it does not have PV established in the system). To export power to the grid, the *Forced Discharge* function must be enabled.
 - If Discharge Power is set to 4kW, and the Discharge Current Limit is set to 200A, with a nominal battery voltage of 50V ($200A * 50V = 10,000W$, indicating the power that the battery can output), then the system will export 4kW to the grid.
 - If the Discharge Current Limit is reduced to 50A (With the other settings unchanged from the previous example), the system will export only 2.5kW ($50A * 50V$).
- If the system has PV and battery, but *Forced Discharge* is disabled:
 - Only excess PV power is exported to the grid. The battery does not discharge to the grid.
- If the system has PV and battery, and *Force Discharge* is enabled:
 - Both PV and battery output their available power to the grid, up to the set limits.

10.2 ESS MODE

- **Unrestricted Mode:** The ESS may import active power from the Area EPS while charging and may export active power to the Area EPS while discharging.
- **Export Only Mode:** The ESS may export active power to the Area EPS during discharging but shall not import active power from the Area EPS for ESS charging purposes.
- **Import Only Mode:** The ESS may import active power from the Area EPS for charging purposes but shall not export active power from the ESS to the Area EPS.
- **No Exchange Mode:** The ESS shall not exchange active power with the Area EPS for charging or discharging purposes.



NOTE: This mode is alternatively known as “No Export Mode”.

Mode	Maximum Current (Charging)	Maximum Current (Discharging)	Overcurrent Protection (Charging)	Overcurrent Protection (Discharging)
Unrestricted Mode	57.7A/208V 50A/240V	50A	72.125A (125%)	62.500A (125%)
Export Only Mode	0A	50A	N/A	62.500A (125%)
Import Only Mode	57.7A/208V 50A/240V	0A	72.125A (125%)	N/A
No Exchange Mode	0A	0A	N/A	N/A

Schematic Diagram

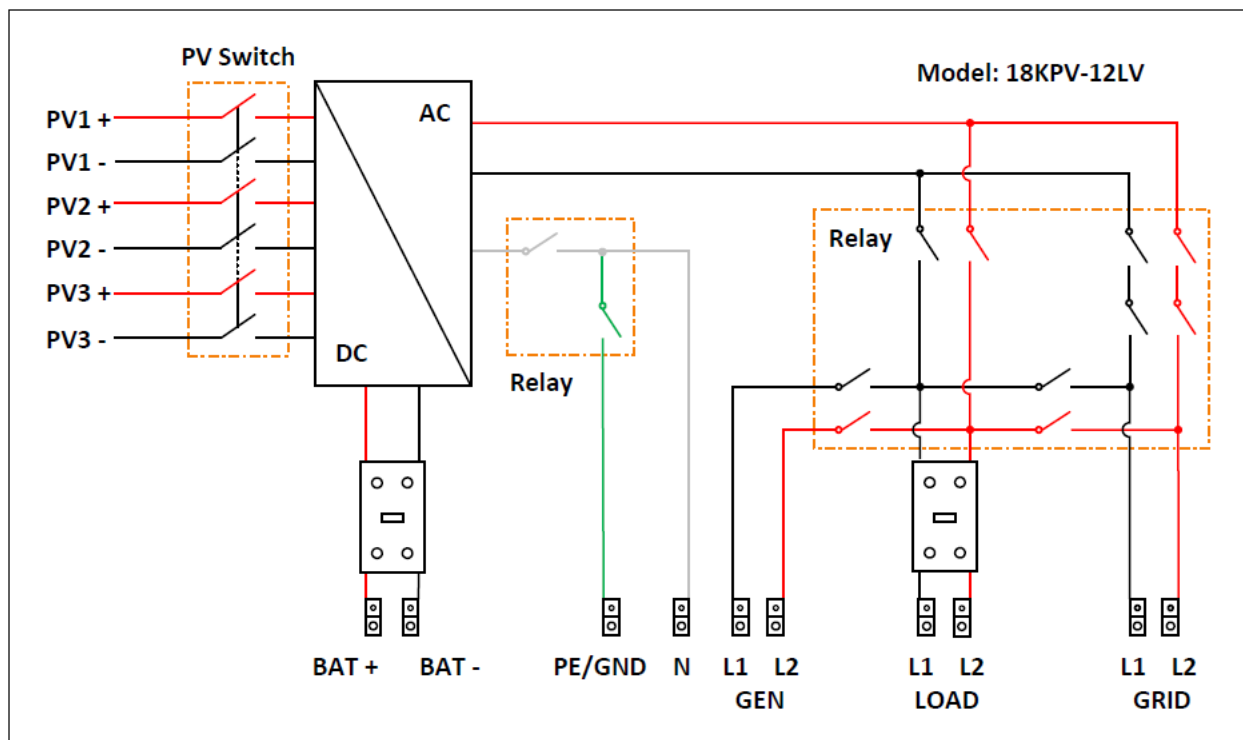

Mode Descriptions

Item	Mode	Time
1	Step Change in Load Test	The average open loop response time: 0.37s The maximum open loop response time:0.85s
2	Step Change in Generation Test	The average open loop response time:0.12s The maximum open loop response time:0.35s
3	Export limiting from all sources	The average open loop response time:1.92s The maximum open loop response time:2.00s
4	Import limiting from all sources	The average open loop response time:1.11s The maximum open loop response time:1.95s
5	ESS Operating Modes Unrestricted Mode	The average open loop response time:0.37s The maximum open loop response time:0.85s
6	ESS Operating Modes Export Only Mode	The average open loop response time:0.22s The maximum open loop response time:0.70s
7	ESS Operating Modes Import Only Mode	The average open loop response time:0.43s The maximum open loop response time:0.95s
8	ESS Operating Modes No Exchange Mode	The average open loop response time:0.12s The maximum open loop response time:0.35s
9	Export limiting from Energy Storage Systems	The average open loop response time:0.22s The maximum open loop response time:0.70s
10	Import limiting to Energy Storage Systems	The average open loop response time:0.43s The maximum open loop response time:0.95s

11. FIRMWARE UPDATES

11.1 FIRMWARE UPDATE VIA EG4® ELECTRONICS APP



NOTE:

When updating firmware through the EG4 app, be sure to have plenty of battery on the device and do not close the application. Make sure the Wi-Fi dongle is connected securely and correctly configured (see section 8.1 for Wi-Fi dongle steps) for the inverter before performing the following steps.

1. Open the EG4 Electronics app on a mobile device and select the “*DOWNLOAD FIRMWARE*” button.
2. Choose the correct firmware file (contact distributor for most up-to-date files) and select “*DOWNLOAD*” on the right side to download the file to the mobile device.
3. Keep the app running and go to the mobile device’s Wi-Fi settings. Connect the mobile device to the dongle’s network. The dongle’s network ID will be the same as the dongle’s serial number.

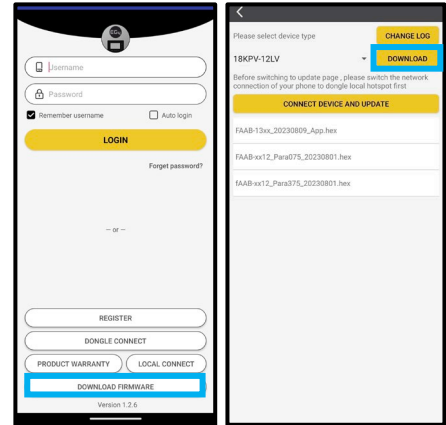

4. Return to the home screen of the app and select “*LOCAL CONNECT*”.
5. After completing step 4, the Local Set Interface will appear. Swipe upward on the screen of the mobile device until the “*UPDATE FIRMWARE*” button is visible at the bottom of the app’s display.
6. Choose the correct installation package in the dropdown box and select “*UPDATE FIRMWARE*” to begin the updating process.

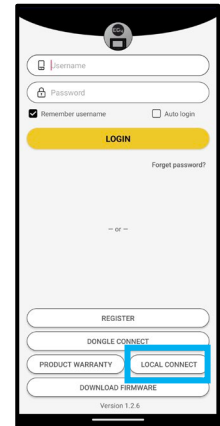

After selecting the “*UPDATE FIRMWARE*” button, the update will begin. Update progress can be viewed via the APP as well as the inverter’s LCD screen. Once the update is completed, a notification will appear confirming that the firmware has been successfully updated. After successfully updating firmware, the inverter will restart itself. Make sure to update all inverters in the same ESS to the latest firmware.

11.2 FIRMWARE UPDATE VIA MONITOR CENTER

1. Distributors and installers can update the firmware for their inverters by using the EG4® Electronics website monitoring system. Contact EG4 to confirm the files are most up to date.
2. Log into the EG4 Electronics Monitor System. Select “Maintenance,” and then select “Remote Update.”
3. Choose the inverter to update and then select “Standard Update”. The Monitor Center will begin updating both firmware files in the inverter. The latest version of the firmware will be displayed in the bottom right window.

The screenshot shows the EG4 Electronics Monitor System interface. The top navigation bar includes 'Monitor', 'Data', 'Configuration', 'Overview', and 'Maintenance' (highlighted with a blue box). Below the navigation bar, there are search filters for 'Station' and 'Serial number', and checkboxes for 'Online Device' and 'Auto Reload'. A table lists three inverters with columns for 'Serial number', 'Dongle', 'Firmware version', 'Connect Status', and 'Action'. The 'Action' column for the first inverter (Serial number 1, Firmware version FAAB-0E0E, Connect Status Lost) has a 'Standard Update' button highlighted with a blue box. A 'Remote Update' button is also highlighted in a yellow box on the left side of the interface.



IMPORTANT:

Throughout the update, the inverter will automatically cycle power as it moves from one update to the next; however, if at any time an “Update Failed” alert appears, restart the full update from the first task. The “Update Failed” alert will only appear in the monitoring center. The software may need more than one attempt to update. If unable to successfully update the firmware, contact the distributor.

12. TROUBLESHOOTING AND MAINTENANCE

12.1 TROUBLESHOOTING WI-FI MODULE

Why is the middle light for the Wi-Fi module flashing?

After setting the correct Wi-Fi password, all three lights should be solidly on. If they are still flashing, try the following.

1. Check if the Wi-Fi is connected and that the correct password has been entered: Use a device to connect to the Wi-Fi hotspot and visit the website 10.10.10.1; the TCP client status should be “Connected”. The username and password are both “admin”. Check the Wi-Fi name and password.

The screenshot shows the MICO IoTOS web interface. The top right corner has a language selector for '中文|English'. The left sidebar contains navigation options: 'Run State', 'Wifi Mode Select', 'AP Mode Setting', 'Station Mode Setting', 'Uart Setting', 'Network Setting', and 'Moduel Management'. The main content area is divided into several sections: 'AP State' (Function, IP, Netmask), 'STA State' (Function, Channel, Signal Strength, IP, Netmask, Gateway), 'Command Mode State' (Function), and 'Network 1 State' (Function, Protocol, TCP Server Number, TCP Client State). The 'TCP Server Number' and 'TCP Client State' fields are highlighted with a blue box.

2. Prior to setting the password, add the dongle to the system. After registering and entering the Wi-Fi SN and PIN, the dongle is automatically added to the system. While logged in, go to the "Configuration" tab. Select "Dongles", and "Add dongle, on monitor.eg4electronics.com to add this dongle to the current configuration if there is more than one dongle. Restart the Wi-Fi module by unplugging it and plugging it back in.

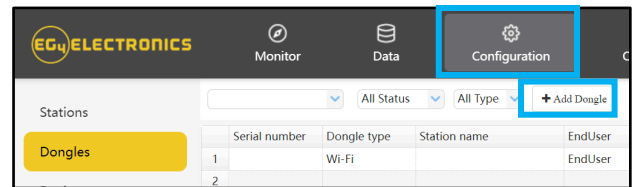

For more information on Wi-Fi dongle troubleshooting, scan the following code:



Dongle Troubleshooting Guide

12.2 REGULAR MAINTENANCE





Inverter Maintenance

- Inspect the inverter every 6 months to check for any damaged cables, accessories, or terminals, and inspect the inverter itself.
- Inspect the inverter every 3 months to verify if the operating parameters are normal and there is no abnormal heating or noise from all components in the system.
- Inspect the inverter every month to confirm nothing covers the inverter heat sink. If there is, shut down the inverter and clear the heat sink to restore proper cooling.

Battery Maintenance

- Follow the manufacturer's requirements for maintenance. When users carry out maintenance on batteries, make sure to fully shut down the inverter for safety.

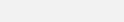
12.3 LED DESCRIPTION

LED	Display	Description	Action
Green LED	Solid lit 	Working normally	No action needed
	Flashing 	Firmware upgrading	Wait until update is complete
Yellow LED	Solid lit 	Warning, inverter may stop working	Needs troubleshooting
Red LED	Solid lit 	Fault, inverter will stop working	Needs troubleshooting

12.4 TROUBLESHOOTING BASED ON LCD SCREEN

Once there is any warning or fault occurring, users can troubleshoot according to the LED status description and the warning/fault information on the LCD screen.

Faults on the LCD and Fault List

If the dot on the left of the fault item is **red**, it means the fault is active.
When the dot is **grey**, it means the fault is inactive.

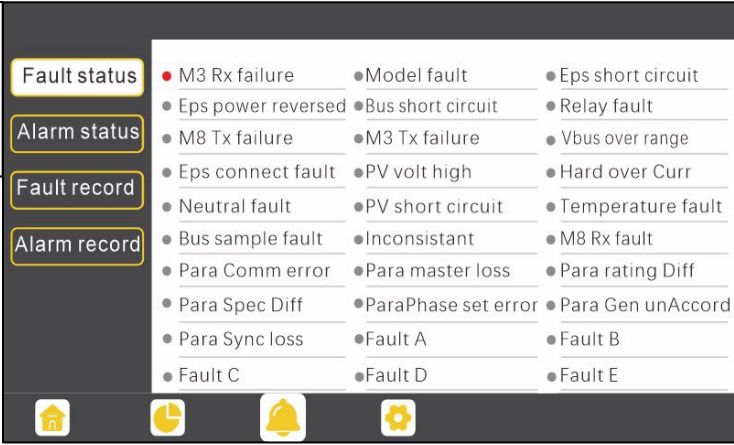

Fault	Meaning	Troubleshooting
M3 Rx failure	M3 microprocessor fails to receive data from DSP	Restart the inverter. If the error persists, contact the supplier.
Model fault	Incorrect model value	
EPS short circuit	Inverter detected short-circuit on load output terminals	<ol style="list-style-type: none"> 1. Check if the L1, L2, and N wires are connected correctly at the inverter load output terminal. 2. Disconnect the load breaker to see if fault remains. If the fault persists, contact the supplier.
EPS power reversed	Inverter detected power flowing into load terminal	Restart the inverter. If the fault persists, contact the supplier.
Bus short circuit	DC Bus is short circuited	
Relay fault	Relay abnormal	
M8 Tx failure	DSP fails to receive data from M8 microprocessor	
M3 Tx failure	DSP fails to receive data from M3 microprocessor	Ensure the PV string voltage is within the inverter specification. If string voltage is within range and this fault persists, contact the supplier.
Vbus over range	DC Bus voltage too high	
EPS connect fault	Load terminal and grid terminal are connected wired incorrectly or reversed	Check if the wires on load terminal and grid terminal are wired correctly. If the fault persists, contact the supplier.
PV volt high	PV voltage is too high	Check if the PV string voltage is within the inverter specification. If string voltage is within range and this fault persists, contact the supplier.
Hard over curr	Hardware level over current protection triggered	Restart the inverter. If the fault persists, contact the supplier.

Neutral fault	Voltage between N and G is greater than 30V	Ensure the neutral wire is connected correctly.
PV short circuit	Short circuit detected on PV input	Disconnect all PV strings from the inverter. If the error persists, contact the supplier.
Temperature fault	Heat sink temperature too high	Install the inverter in a place with good ventilation and no direct sunlight. If the installation site is okay, check if the NTC connector inside the inverter is loose.
Bus sample fault	Inverter detected DC bus voltage lower than PV input voltage	Restart the inverter, if the fault persists, contact the supplier.
Inconsistent	Sampled grid voltage values of DSP and M8 microprocessor are inconsistent	
M8 Rx fault	M8 microprocessor fails to receive data from DSP	
Para Comm error	Parallel communication abnormal	<ol style="list-style-type: none"> 1. Check whether the connection of the parallel cable is loose. Connect the parallel cable correctly. 2. Ensure the PIN status of the CAN communication cable from the first to the end inverter is connected correctly.
Para master loss	No Master in the parallel system	<ol style="list-style-type: none"> 1. If a Master has been configured in the system, the fault will automatically be removed after the Master works. 2. If a Master has not been configured and there are only Slaves in the system, set the Master first. Note: For a single-unit system, the role of the inverter should be set as "1 phase Master."
Para rating Diff	Rated power of parallel inverters are inconsistent	Confirm that the rated power of all inverters is the same.
Para Phase set error	Incorrect setting of phase in parallel	First confirm the wiring for the parallel system is correct. Once verified, connect each inverter to the grid. The system will automatically detect the phase sequence and the fault automatically resolves after the phase sequence is detected. If the fault persists, contact the supplier.
Para Gen in Accord	Inconsistent generator connection in parallel	Some inverters are connected to generators, and some are not. Confirm <i>all</i> inverters in parallel are connected to common generator output, or <i>none</i> are connected to generators.
Para sync loss	Parallel inverter fault	Restart the inverter. If the fault persists, contact the supplier.

Alarm on the LCD and Alarm List

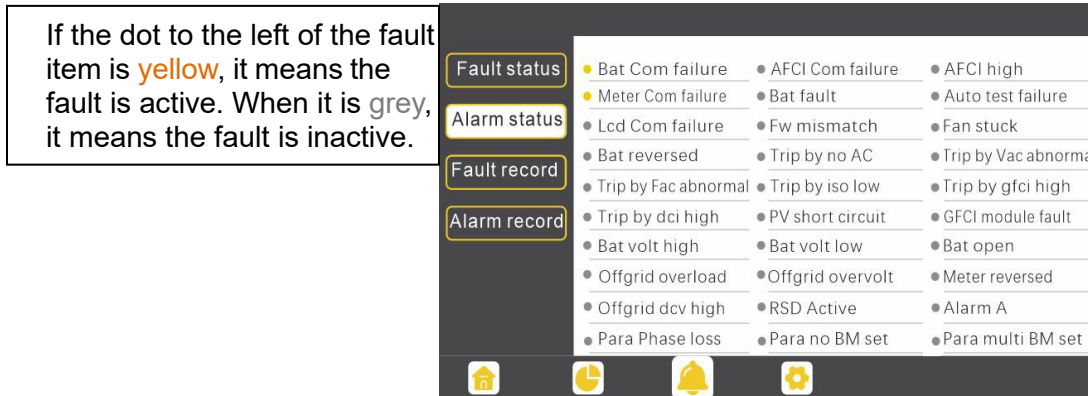

Alarm	Meaning	Troubleshooting
Bat com failure	Inverter fails to communicate with battery	Check if the communication cable pinout is correct, and if the correct battery brand on the inverter's LCD is selected. If all is correct but this alarm persists, contact the supplier.
AFCI com failure	Inverter fails to communicate with AFCI module	Restart inverter. If the error continues, contact the supplier.
AFCI high	PV arc fault is detected	Check each PV string for correct open-circuit voltage and short-circuit current. If the PV strings are in good condition, clear the alarm on the inverter LCD.
Meter com failure	Inverter fails to communicate with the meter	Check if the communication cable is connected correctly and in good working condition. Restart inverter. If the alarm persists, contact the supplier.
Bat Fault	Battery cannot charge or discharge	<ol style="list-style-type: none"> 1. Check the battery communication cable for correct pinout on both inverter and battery end. 2. Check if an incorrect battery brand is selected. 3. Check if there is fault on battery's indicator. If there is a fault, contact the battery supplier.
LCD com failure	LCD fails to communicate with M3 microprocessor	Restart the inverter. If the fault still occurs, contact the supplier.
Fwm mismatch	Firmware version mismatch between the microprocessors	Update the inverter; if the fault persists, contact the supplier.
Fan stuck	Cooling fan(s) are stuck	Check for debris, if the issue persists, contact the supplier.
Trip by GFCI high	Inverter detected leakage current on AC side	<ol style="list-style-type: none"> 1. Check if there is ground fault on grid and load side. 2. Restart inverter. If the alarm persists, contact the supplier.
Trip by dci high	Inverter detected high DC injection current on Grid terminal	Restart inverter. If the alarm persists, contact the supplier.

PV short circuit	Inverter detected a short circuit in PV input	<ol style="list-style-type: none"> 1. Check whether each PV string is connected correctly. 2. Restart inverter. If the alarm persists, contact the supplier.
GFCI module fault	GFCI module is abnormal	Restart inverter. If the alarm persists, contact the supplier.
Bat volt high	Battery voltage too high	Check whether the battery voltage exceeds 59.9V; battery voltage should be within inverter specification.
Bat volt low	Battery voltage too low	Check whether the battery voltage is under 40V; battery voltage should be within inverter specification.
Bat open	Battery is disconnected from inverter	Check battery breaker or battery fuse. Reconnect as needed.
Off-grid overload	Overload on Load terminal	Check if load power on inverter LOAD terminal is within inverter specification.
Off-grid overvolt	Load voltage is too high	Restart inverter. If the alarm persists, contact the supplier.
Meter reversed	Meter connection is reversed	Check if the meter communication cable is connected correctly on the inverter and meter sides.
Off-grid dcv high	High DC voltage component on load output when running off-grid	Restart inverter. If the alarm persists, contact the supplier.
RSD Active	Rapid shutdown activated	Check if the RSD switch is pressed.
Para phase loss	Phase losing in parallel system	Confirm that the wiring of the inverter is correct. If the Master is set to 3-phase Master, the number of parallel inverters must be ≥ 3 . (The grid input for each inverter should be connected correctly to Grid L1, L2, L3.) If the Master is set to 2x 208 Master, the number of parallel inverters needs to be ≥ 2 . (And the grid input of each inverter should be connected correctly to Grid L1, L2, L3.)
Para no BM set	Master is not set in the parallel system	Set one of the inverters in the parallel system as the Master.
Para multi BM set	Multiple Primaries have been set in the parallel system	There are at least two inverters set as the Master in the parallel system. Keep one Master and set the other as Slave.

13. CHANGELOG

V2.7.5

- Added information and QR code to Spec Sheet about derating power to install in higher altitudes.

V2.7.4

- Added Warning note to section 7.3 page 25

V2.7.3

- Modified “Recommended Battery Capacity Per Inverter” from >200Ah to ≥ 300 Ah in spec sheet.
- Added PV Volt Protection High value to spec sheet

V2.7.2

- Updated “CT Typing” information in conjunction with UL3141 update. See Sect. 7.3.
- Created/Added sections 10 – “Power Control System”, 10.1 – “Export Limiting From All Sources (PEL), and 10.2 – “ESS Mode” to cover PCS information
- Added additional step of setting inverter to standby before full shutdown

V2.7.1

- Updated third-party monitoring information

V2.7.0

- Added an asterisk to MPPT Operating Voltage Range line in spec sheet
- Added note after the spec sheet regarding MPPT Operating Voltage Range asterisk

V2.6.9

- Modified communication protocol selection information and structure in section 7.2
- Modified verbiage in section 9.4 for External E-Stop Switch

v2.6.8

- Added French warnings/danger statements
- Added Locked Rotor Amps value to spec sheet

v2.6.5

- Removed word “Meter” from section 6.2

v2.6.4

- Modified wire strip length in PV connections and AC connections steps.

v2.6.3

- Modified verbiage on Packing List

v2.6.2

- Modified warranty information

v2.6.1

- Added recommended generator THD (Section 6.3)

v2.5

- Modified wiring diagrams (Section 7)

- Updated Warranty information (9/16/2024)

v2.4.1

- Removed duplicate “Frequency” value from spec sheet.

v2.2.1

- Added straight-through cable pinout image for more clarity (Section 5.9.1)

v2.2.0

- Removed knockout plugs from Section 5.1, packing list.
- Modified knockout pattern images to reflect latest changes. (Section 5.3)
- Modified connection board images to reflect added +12V/G terminals. (Section 5.3, 12.2)

v2.1.0

- Expanded upon External RSD section with new diagrams and instructions in Section 11.2
- Added and modified existing settings descriptions for “Off-Grid Enable” and “Battery Priority”
- Expanded on AC Couple settings descriptions
- Added a note below AC Coupling explaining how to achieve frequency shifting

v2.0.3

- Added additional context behind BMS communications

v2.0.2

- Revised wiring diagrams for 3-phase with 2 and 3 inverters
- Formatting changes for readability and flow
- Added QR code to cover page for latest documents

v2.0.1

- Revised multiple sections for formatting/spacing purposes
- Added 3-phase wiring diagram with 2 inverters to wiring diagram section

v2.0.0

- Updated multiple sections
 - Added wiring diagrams
 - Updated existing line diagrams
 - Replaced all images with current models/applications
 - Integrated new hybrid settings guide
 - Removed term “EPS” and replaced with “inverter”
 - Updated GUI images to represent company branding
 - Expanded on Wi-Fi dongle installation
 - Updated BMS Communication section to reflect LifePower4 batteries needing FW update for closed-loop comms



CONTACT US

support@eg4electronics.com

(903) 609-1988

www.eg4electronics.com