

Installation Manual

Generac PV Link™

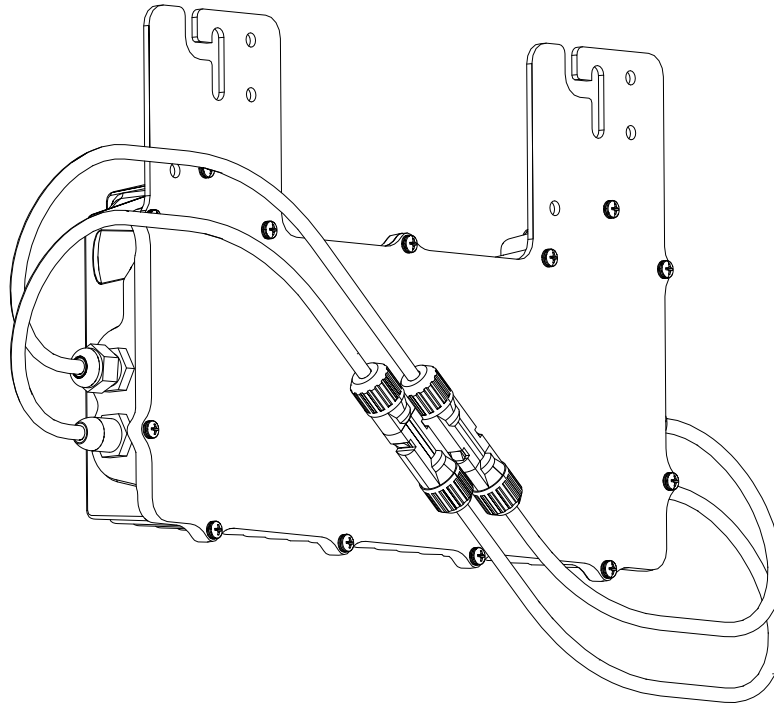

010023



WARNING

Loss of life. This product is not intended to be used in a critical life support application. Failure to adhere to this warning could result in death or serious injury.

(000209b)

Register your Generac product at:

<https://register.generac.com/>

1-888-GENERAC
(888-436-3722)

Para español, visita: <http://www.generac.com/service-support/product-support-lookup>

Pour le français, visiter: <http://www.generac.com/service-support/product-support-lookup>

SAVE THIS MANUAL FOR FUTURE REFERENCE

Use this page to record important information about your Generac Product

Record Generac PV Link™ and Generac SnapRS™ information for your PWRcell system on this page.

When contacting a Generac Products Authorized Service Dealer (ASD) about parts and service, always supply complete model number and serial number information.

Operation and Maintenance: Proper maintenance and care of the energy storage system ensures a minimum number of problems and keeps operating expenses at a minimum. It is the operator's responsibility to perform all safety checks, to verify that all maintenance for safe operation is performed promptly, and to have the equipment checked periodically by an ASD. Normal maintenance, service and replacement of parts are the responsibility of the owner/operator and, as such, are not considered defects in materials or workmanship within the terms of the warranty. Individual operating habits and usage may contribute to the need for additional maintenance or service.

Table 1 - Generac PV Link Important Information

PV Link Number	Location	Serial Number	RCP Number	Parallel Input?	Number of SnapRS	SnapRS Date of Manufacture
1						
2						
3						
4						
5						
6						

 **WARNING**

CANCER AND REPRODUCTIVE HARM

www.P65Warnings.ca.gov

(000393a)

Table of Contents

Section 1: Safety Rules & General Information

Introduction	1
Read This Manual Thoroughly	1
Safety Rules	1
How to Obtain Service	1
General Hazards	2
PVRSE Warning	2
Electrical Hazards	3
Safety Shutdown	3

Section 2: General Information

Specifications	5
Serial Number Location	5
Unit Dimensions	5
About PV Link	6
GFCI Information	6
AFCI Information	6
PVRSS Information	6
Component Locations	6

Section 3: Installation Design

Installation Design Worksheet	7
--------------------------------------------	----------

Section 4: PVRSS Compliance Guidelines

2011 NEC and Older Editions	9
2014 NEC	9
2017 and 2020 NEC	9

Section 5: Mounting and Connecting

Installation Guidelines	11
Attachment and Grounding	11
Installing to Metallic or Grounded Structures	11
Installing to Nonmetallic or Ungrounded Structures ..	11
Installing to a Grounded Rail	11
Connecting to Inverter	12
Connecting PV Modules	12
2014 NEC and Earlier Editions	12
2017 and 2020 NEC Compliant Systems	13

Section 6: Operating Instructions

User Interface via Inverter	15
Commissioning the REbus System	15
PVRSS Commissioning with SnapRS Devices	15
PVRSS Commissioning Troubleshooting	16
Disabling PV Link	17
AFD Self-Test	17
PVRSS Self-Test	17

Section 7: Maintenance

Maintenance	19
Service	19

This page intentionally left blank.

Section 1: Safety Rules & General Information

Introduction

Thank you for purchasing a Generac PV Link™. The PV Link connects solar photovoltaic (PV) modules to the Generac PWRcell™ Inverter for efficient, safe, and smart transfer of solar generated power.

This manual provides instructions for installing PV Link, including mounting and wiring information. It also contains information for installing and commissioning Generac SnapRS™ devices. Consult the installation and operation manuals for other Generac PWRcell system components, as applicable.

The information in this manual is accurate based on products produced at the time of publication. The manufacturer reserves the right to make technical updates, corrections, and product revisions at any time without notice.

Read This Manual Thoroughly



Consult Manual. Read and understand manual completely before using product. Failure to completely understand manual and product could result in death or serious injury. (000100a)

If any section of this manual is not understood, contact the nearest Independent Authorized Service Dealer (IASD) or Generac Customer Service at 1-888-436-3722 (1-888-GENERAC), or visit www.generac.com for assistance. The owner is responsible for correct maintenance and safe use of the unit.

This manual must be used in conjunction with all other supporting product documentation supplied with the product.

SAVE THESE INSTRUCTIONS for future reference. This manual contains important instructions that must be followed during placement, operation, and maintenance of the unit and its components. Always supply this manual to any individual that will use this unit, and instruct them on how to correctly start, operate, and stop the unit in case of emergency.

Safety Rules

The manufacturer cannot anticipate every possible circumstance that might involve a hazard. The alerts in this manual, and on tags and decals affixed to the unit, are not all inclusive. If using a procedure, work method, or operating technique that the manufacturer does not specifically recommend, verify that it is safe for others and does not render the equipment unsafe.

Throughout this publication, and on tags and decals affixed to the unit, DANGER, WARNING, CAUTION, and NOTE blocks are used to alert personnel to special instructions about a particular operation that may be hazardous if performed incorrectly or carelessly. Observe them carefully. Alert definitions are as follows:

DANGER

Indicates a hazardous situation which, if not avoided, will result in death or serious injury.

(000001)

WARNING

Indicates a hazardous situation which, if not avoided, could result in death or serious injury.

(000002)

CAUTION

Indicates a hazardous situation which, if not avoided, could result in minor or moderate injury.

(000003)

NOTE: Notes contain additional information important to a procedure and will be found within the regular text of this manual.

These safety alerts cannot eliminate the hazards that they indicate. Common sense and strict compliance with the special instructions while performing the action or service are essential to preventing accidents.

How to Obtain Service

For assistance, contact the nearest Independent Authorized Service Dealer (IASD) or Generac Customer Service at 1-888-GENERAC (1-888-436-3722), or visit www.generac.com.

When contacting Generac Customer Service, always supply the complete model and serial number of the unit as given on its data decal located on the unit. Record the model and serial numbers in the spaces provided on the front cover of this manual.

General Hazards

DANGER

Automatic start-up. Disconnect utility power and render unit inoperable before working on unit. Failure to do so will result in death or serious injury.

(000191)

WARNING

Risk of injury. Do not operate or service this machine if not fully alert. Fatigue can impair the ability to service this equipment and could result in death or serious injury.

(000215)



WARNING

Loss of life. This product is not intended to be used in a critical life support application. Failure to adhere to this warning could result in death or serious injury.

(000209b)

WARNING

Equipment damage. Connect only to REbus-compatible devices to the DC bus. Never connect to any other DC power source. Connecting to other DC power sources could result in equipment damage.

(000598)

WARNING

Electric shock. Only a trained and licensed electrician should perform wiring and connections to unit. Failure to follow proper installation requirements could result in death, serious injury, and equipment or property damage.

(000155a)

WARNING

Equipment damage. Only qualified service personnel may install, operate, and maintain this equipment. Failure to follow proper installation requirements could result in death, serious injury, and equipment or property damage.

(000182a)

WARNING

Equipment damage. Never open Generac PV Link. The optimizer is factory-sealed and contains no field-serviceable parts. Opening the optimizer could result in equipment damage.

(000655)

WARNING

Equipment damage. Never operate Generac PV Link in ambient temperatures greater than 158° F (70° C). Operating Generac PV Link in high temperature conditions will result in equipment damage.

(000669)

WARNING

Hot Surfaces. Locate and install the Generac PV Link so as to avoid inadvertent contact. When operating in hot weather the optimizer will become hot and could result in personal injury.

(000670)

- Connecting Generac PWRcell to the electric utility grid must only be done after receiving prior approval from the utility company.
- Only competent, qualified personnel should install, operate, and service this equipment. Strictly comply to local, state, and national electrical and building codes. When using this equipment, comply with regulations established by the National Electrical Code (NEC), CSA Standard; the Occupational Safety and Health Administration (OSHA), or the local agency for workplace health and safety.
- Protection against lightning surges in accordance with local electric codes is the responsibility of the installer.
- If working on this equipment while standing on metal or concrete, place insulative mats over a dry wood platform. Work on this equipment only while standing on such insulative mats.
- Never work on this equipment while physically or mentally fatigued.
- Any voltage measurements should be performed with a meter that meets UL3111 safety standards, and meets or exceeds overvoltage class CAT III.

PVRSE Warning

This Photovoltaic Rapid Shutdown Equipment (PVRSE) does not perform all of the functions of a complete Photovoltaic Rapid Shutdown System (PVRSS). This PVRSE must be installed with other equipment to form a complete PVRSS that meets the requirements of NEC (NFPA 70) section 690.12 for controlled conductors outside the array. Other equipment installed in or on this PV system may adversely affect the operation of the PVRSS. It is the responsibility of the installer to ensure the completed PV system meets the rapid shutdown functional requirements. This equipment must be installed according to the manufacturer's installation instructions.

Electrical Hazards



⚠ DANGER

Electrocution. Water contact with a power source, if not avoided, will result in death or serious injury.

(000104)



⚠ DANGER

Electrocution. In the event of electrical accident, immediately shut power OFF. Use non-conductive implements to free victim from live conductor. Apply first aid and get medical help. Failure to do so will result in death or serious injury.

(000145)



⚠ DANGER

Electrocution. Turn battery disconnect OFF and de-energize REbus before touching terminals. Failure to do so will result in death, serious injury, equipment and property damage.

(000599)



⚠ DANGER

Electrocution. Verify electrical system is properly grounded before applying power. Failure to do so will result in death or serious injury.

(000152)



⚠ DANGER

Electrocution. Do not wear jewelry while working on this equipment. Doing so will result in death or serious injury.

(000188)

⚠ WARNING

Electric Shock. Avoid contact with DC conductors. DC conductors of this photovoltaic system are ungrounded and may be energized regardless of sun exposure. Contact with conductors could result in death or serious injury.

(000666)



⚠ WARNING

Electrocution. Potentially lethal voltages are generated by this equipment. Render the equipment safe before attempting repairs or maintenance. Failure to do so could result in death or serious injury.

(000187)

Safety Shutdown



⚠ DANGER

Electrocution. Initiate a system-wide safety shutdown and turn PWRcell Disconnect Switch OFF on all connected batteries before performing service. Failure to do so will result in death, serious injury, equipment and property damage.

(000600)

NOTE: A loss of grid power will not de-energize REbus in a system configured to island or provide backup power.

See [Figure 1-1](#). Shutdown button (A) on the Generac PWRcell Inverter control panel activates Safety Shutdown. Safety Shutdown signals connected devices to shutdown and limit output voltage to a safe level. An external shutdown button may also be installed, given appropriate labeling. See the Generac PWRcell Inverter Installation Manual for more information.

To enter Safety Shutdown, press and hold Shutdown (A). Safety shutdown LED (B) will illuminate and LCD screen (C) will indicate Safety Shutdown has been initiated.

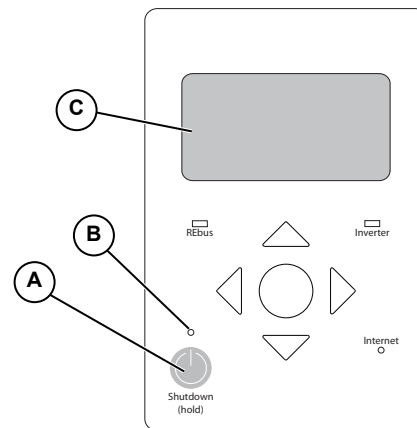

009918

Figure 1-1. Safety Shutdown Button (Located on Inverter Control Panel)

Upon entering Safety Shutdown, a shutdown signal will be transmitted to all devices connected to REbus. In Safety Shutdown:

- Generac PWRcell Inverter will disconnect from the grid.
- Generac PWRcell Inverter will stop sourcing power to REbus, and immediately disable all sources on REbus by sending a global shutdown signal.
- All Generac PV Link Optimizers will disconnect their output.
- Safety Shutdown LED (B) will be illuminated to show that the inverter has entered safety shutdown. REbus DC bus voltage will be displayed on the inverter screen.

This page intentionally left blank.

Section 2: General Information

Specifications

Description	Units	S2502
Rated power	W	2500 (continuous)
Peak efficiency	%	99
MPPT input voltage	VDC	60–360
Rated power input voltage	VDC	200–360
Maximum input voltage	VDC	420 (absolute maximum)
Maximum output voltage	VDC	420 (open circuit)
Nominal output	-	REbus DC nanogrid (380 VDC + data)
Maximum output current	A	8
Standby power	W	<1
Topology	-	Boost converter
Protections	-	Ground-fault protection, arc-fault protection
Maximum operating temperature	°F (°C)	158 (70)
Enclosure	-	Type 3R
Weight	lb (kg)	7.3 (3.3)

Specifications are subject to change without notice. Refer to the product specification sheet for complete list.

Serial Number Location

Refer to **Figure 2-1** to locate the unit serial number and RCP number (A). Record the information from this tag in **Table 1: Generac PV Link Important Information** on the inside front cover of this manual so it is available if the tags are lost or damaged. When requesting assistance, you may be asked to provide this information.

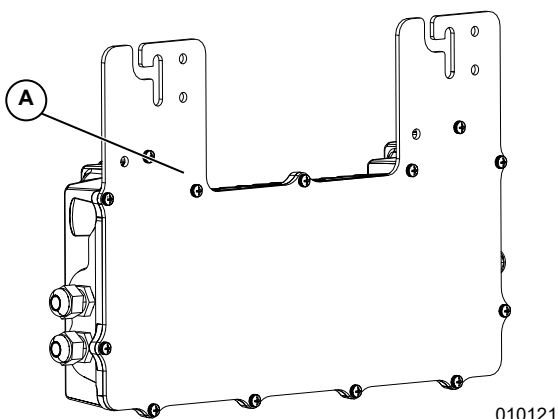

Figure 2-1. Serial Number Location

Unit Dimensions

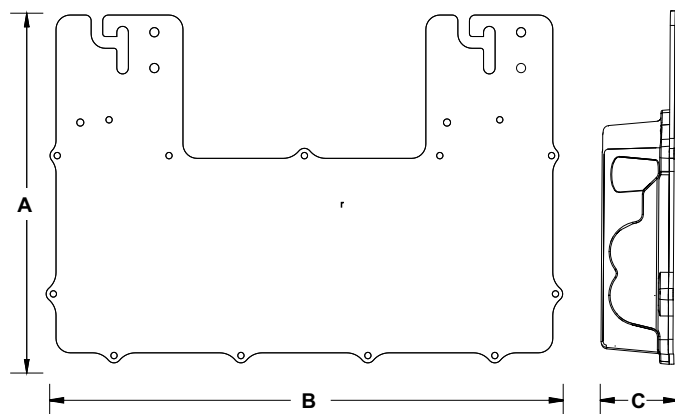

Figure 2-2. Unit Dimensions

A	9.6 (243)
B	15.4 in (390 mm)
C	2 in (50 mm)

About PV Link

The PV Link is a nonisolated, interleaved DC-DC converter that boosts PV input to a higher voltage and outputs it to Rebus™, Generac's regulated 380 VDC bus. The PV Link provides droop-mode power management, enabling multiple optimizers to connect in parallel on a common bus, and its DC output carries a bidirectional power line communication (PLC) protocol for communicating with inverters and other devices on REbus.

The PV Link is sealed in a type 3R enclosure at the factory and is designed for attachment to standard PV racking. Safety features include ground fault detection, arc fault detection, and rapid shutdown capability.

GFCI Information

The PV Link's internal ground-fault circuit interrupter (GFCI) is designed to trip at 240 mA (\pm 40 mA) of PV DC voltage ground current. Ground faults are displayed on the Generac PWRcell Inverter control panel. The PV Link meets the ground-fault protection requirements in NEC Article 690.41(B).

AFCI Information

The PV Link is a Photovoltaic DC Arc-Fault Circuit Protection Type 1 device that incorporates an internal arc fault circuit interrupter (AFCI) and meets the Arc-Fault circuit protection requirement in NEC Article 690.11.

PVRSS Information

PV rapid shutdown system (PVRSS) requirements have evolved over time and are defined by the National Electrical Code (NEC) in conjunction with UL 1741. Determine what level of rapid PV shutdown is required for your jurisdiction.

- The 2011 NEC and older editions do not require PVRSS capability.
- The 2014 NEC requires rapid shutdown only on the conductors leaving the PV array.
- The 2017 and 2020 NEC require rapid shutdown at the PV module level and on the conductors leaving array.

PV Link is a PV rapid shutdown system equipment (PVRSE) component within a PVRSS. It only provides rapid shutdown for the conductors leaving the array. SnapRS devices are required for PV module level rapid shutdown. See [PVRSS Compliance Guidelines](#) for more information.

Component Locations

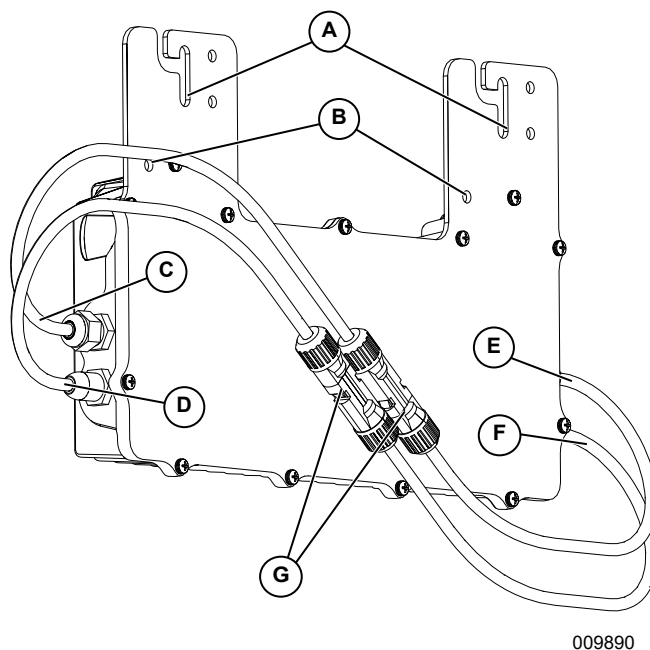

Figure 2-3. Component Locations

- A Attachment Flange Slots
- B Grounding Terminals
- C REBus DC Nanogrid Output Negative (-) Lead
- D REBus DC Nanogrid Output Positive (+) Lead
- E PV Substring Input Negative (-) Lead
- F PV Substring Input Positive (+) Lead
- G MC4 Connectors

Section 3: Installation Design

Installation Design Worksheet

Use this worksheet to determine the maximum number of PV modules of a given type that can be connected to a PV Link.

NOTE: Fewer PV modules can be used as long as the minimum MPPT input voltage is met.

1. Calculate an adjusted open circuit voltage (VOC) for the module being installed using the applicable NEC cold factor from **Table 1: NEC Cold Factor Conversion**.

NOTE: The temperature correction factor listed on the module nameplate can be used if available.

Panel VOC	X	NEC Cold Factor	=	Adjusted VOC

2. Divide the PV Link Max VOC by the Adjusted VOC from step 1 and round down to determine the number of panels that can be connected in series to the PV Link without exceeding the open-circuit voltage limit.

PV Link Max VOC	÷	Adjusted VOC	=	VOC Limit Result
420 V				

3. Divide the PV Link voltage at maximum power (VMP) by the panel VMP and round down to determine the number of panels that can be connected in series to the PV Link without exceeding maximum power voltage.

PV Link Max VMP	÷	Panel VMP	=	VMP Limit Result
360 V				

4. Compare the results from step 2 and step 3 and choose the smaller number. Round down to the nearest integer and record it below. This is the maximum number of modules of this type that can be connected to the PV Link given the specified NEC cold factor.

Maximum Panels per Substring

Table 1 - NEC Cold Factor Conversion

Minimum Temperature (°F)	NEC Cold Factor	Minimum Temperature (°C)
49 to 41	1.08	9 to 5
40 to 32	1.10	4 to 0
31 to 23	1.12	-1 to -5
22 to 14	1.14	-6 to -10
13 to 5	1.16	-11 to -15
4 to -4	1.18	-16 to -20
-5 to -13	1.20	-21 to -25
-14 to -22	1.21	-26 to -30
-23 to -31	1.23	-31 to -35
-32 and below	1.25	-36 and below

This page intentionally left blank.

Section 4: PVRSS Compliance Guidelines

2011 NEC and Older Editions

The 2011 NEC and older editions do not require any PVRSS compliance. Installation that follows the instructions in this manual is all that is required.

2014 NEC

The 2014 NEC 690.12 introduced a new requirement for PV systems that is commonly referred to as PV rapid shutdown.

To meet 2014 NEC compliance:

1. Install the Generac PWRcell Inverter as specified in the Generac PWRcell Inverter Installation Manual.
2. Install the PV Link as specified in this manual.
3. Press the Shutdown button on the inverter control panel for several seconds until the system de-energizes. See [Safety Shutdown](#) for more information.

NOTE: A remotely located external shutdown switch can be an additional PVRSS initiator, if so equipped. See the Generac PWRcell Inverter Installation Manual for more information.

Rapid shutdown response time is less than 30 seconds.

2017 and 2020 NEC

The 2017 and 2020 NEC have PVRSS requirements mandating the need to reduce voltages of controlled conductors to less than 80 VDC within the array, as well as some specification for the location of the PVRSS initiator and its labeling.

To meet 2017 and 2020 compliance:

1. The 2017 and 2020 NEC requires the PVRSS initiator be located at a readily accessible location outside the building.
 - The DC disconnect under the Generac PWRcell Inverter cover labeled PV can be used as the PVRSS initiation device. This requires the inverter to be mounted externally and in close proximity to the utility meter.

NOTE: Provide signage indicating the PVRSS initiation device is the REbus PV DC disconnect located under the front cover of the inverter.

- An externally mounted PVRSS initiation device is required to be installed at a readily accessible location when the Generac PWRcell Inverter is installed within a one- or two-family dwelling unit.

NOTE: Provide signage indicating where the PVRSS initiation device is located.

2. Provide signage complying with section 690.565(C) of the NEC (NFPA 70), stating all conductors are controlled.
3. Install the Generac PWRcell Inverter as specified in the Generac PWRcell Inverter Installation Manual.
4. Install the PV Link to the PV array using a Generac SnapRS™. These devices attach to module MC4 connectors between panels and allow the system to achieve 2017 NEC and 2020 NEC 690.12 compliance.

NOTE: Install one SnapRS to the negative whip (-) of each PV module connected to the PV Link. See the Generac SnapRS Installation Manual for more information.

5. Install the PV Link. See [Installation Guidelines](#) for more information.

Upon initiation of rapid shutdown, both inputs and outputs of the PV Link are controlled to be less than 80 VDC. Rapid shutdown response time is less than 30 seconds, in accordance with section 690.12 of the NEC (NFPA 70).

This page intentionally left blank.

Section 5: Mounting and Connecting

Installation Guidelines

⚠ WARNING

Hot Surfaces. Locate and install the Generac PV Link so as to avoid inadvertent contact. When operating in hot weather the optimizer will become hot and could result in personal injury.

(000670)

- Install PV Links close to the edge of the array for best cooling and easier service access.
- Calculate maximum substring length using the [Installation Design](#) worksheet in Section 3 of this manual.
- The modules within each substring must be the same type, and all should be mounted at the same pitch and orientation.
- When installing a system with multiple PV Links, it is not necessary to match the number of modules, roof pitch, or orientation across all substrings in an array.
- Ensure at least a 1 in (25.4 mm) clearance between the heatsink fins and adjacent surfaces to allow sufficient air flow for cooling.
- The PV Link can be installed in any orientation. Cooling is most effective if fins are oriented vertically.
- Mount the optimizer at least 3 ft (0.9 m) from the ground.
- Ensure the PVRSE enclosure is a minimum ½ in (12.7 mm) from the PV module substrate.
- Review the PV module instructions to determine if any restrictions for mounting devices under the module exist as part of the PV module listing.

Attachment and Grounding

⚠ CAUTION

Equipment damage. Never leave the PV Link MC4 connectors open and exposed to the atmosphere overnight or during rain. Unwired connectors should remain plugged together as originally packaged. Failure to do so could cause equipment damage.

(000657)

NOTE: Proper grounding is necessary for REbus communication.

Installing to Metallic or Grounded Structures

See [Figure 5-1](#). Install the PV Link with label (A) facing up. Attachment flange slots (B) accept fasteners up to M8 or 5/16" in diameter.

Installing to Nonmetallic or Ungrounded Structures

- Use two fasteners appropriate for the structure.
- See [Figure 5-1](#). Fasten to grounding terminal (C) the equipment grounding conductor using a lug (such as, 6-14 AWG Copper Set Screw Lug, McMaster P/N: 6923K31) or equivalent.
- Use listed bonding hardware only.
- Size equipment grounding conductor per NEC requirements and torque per manufacturer specifications.

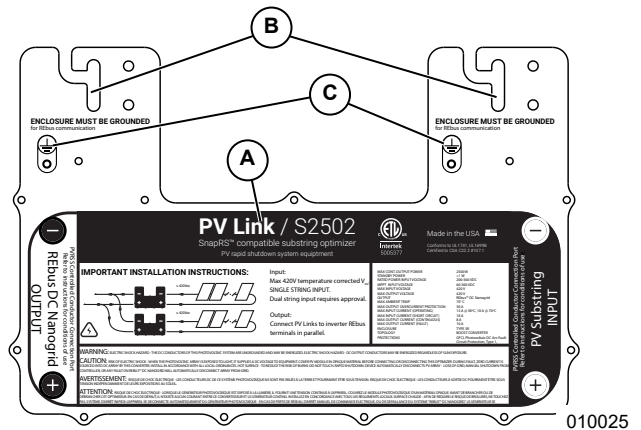

Figure 5-1. Grounding Terminal Location

Installing to a Grounded Rail

- See [Figure 5-1](#). Use two rail-compatible fasteners (D) to secure the PV Link to the grounded rail.
- Use a WEED clip (Wiley P/N: 30020098) or equivalent grounding washer (E) between the rail and attachment flange to penetrate the rail's anodized coating.
- Torque fasteners to 10 N-m for M6 and 25 N-m for M8, or according to the clip manufacturer's instructions.

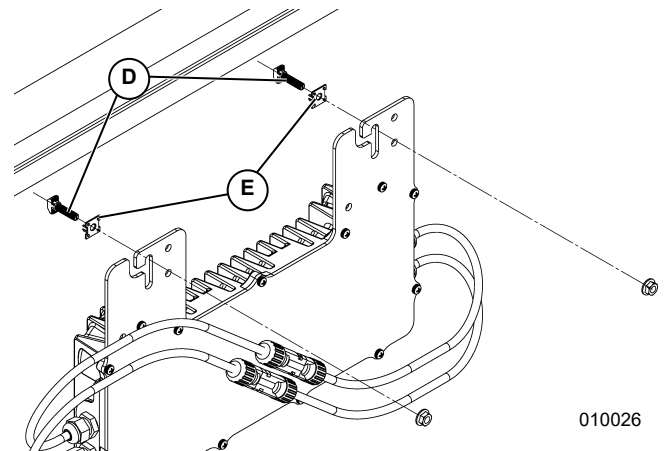

Figure 5-2. Attaching to a Grounded Metal Rail

Connecting to Inverter

CAUTION

Equipment damage. Connect the PV Link output to a REbus-compatible device (± 190 VDC nominal regulated DC bus) only. Connecting to conventional PV inverters or any other device could cause equipment damage.

(000659)

See [Figure 5-3](#). Connect each PV Link output to the REbus DC nanogrid and inverter.

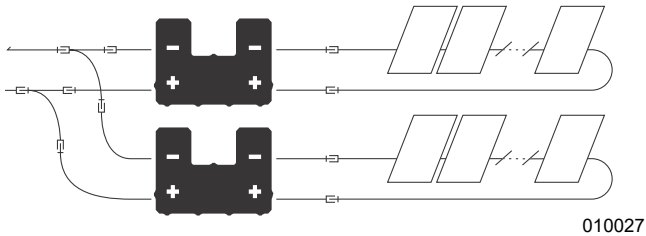

Figure 5-3. Connecting PV Link Optimizer

When connecting optimizers to the inverter consider the following:

- Do not reverse the input and output or cross-wire polarity. To avoid confusion, complete the wiring of the PV Link output before installing PV modules.
- Do not connect PV Link optimizers in series.
- Connect multiple PV Link outputs in parallel. To connect in parallel, connect RE- to RE- and RE+ to RE+.
- Current adds when connecting optimizers in parallel. The maximum output current of each PV Link is 8 A. When wiring PV Link outputs to the inverter, observe temperature ratings and current-carrying capacity of the wire used, including appropriate NEC derating factors.

NOTE: Multiple home-runs will be necessary in larger systems.

- Connect field wiring to the PV Link with MC4 PV connectors (Multi-Contact P/N: 32.0010P0001-UR/ 32.0011P0001-UR or equivalent).
- Mark positive REbus field wiring leads with red insulation or flagging.
- Mark negative REbus field wiring leads with blue insulation or flagging.
- Connect multiple optimizers in parallel, using MC4 branch connectors (Multi-Contact P/N: 32.0018/ 32.0019 or equivalent).

Connecting PV Modules

CAUTION

Equipment damage. Never leave the PV Link MC4 connectors open and exposed to the atmosphere overnight or during rain. Unwired connectors should remain plugged together as originally packaged. Failure to do so could cause equipment damage.

(000657)

CAUTION

Equipment damage. Never connect PV Link to any other power source. The optimizer is designed to work with series connected PV modules only. Connecting the optimizer to any other power source could cause equipment damage.

(000661)

NOTE: Warranty does not cover water ingress through wiring from external connections due to poor wiring practices.

2014 NEC and Earlier Editions

For NEC 2014 compliant systems, connect the substring PV modules in series.

To install PV modules in series:

1. Connect the negative lead of the first module in the string to the PV Link at the location marked PV Substring Input (-). See [Component Locations](#) for PV Input location.
2. Connect the first module's positive lead to the second module's negative lead.
3. Continue connecting the substring module leads in series until the last module is reached.
4. Connect the positive lead of the last module in the substring to the PV Link at the location marked PV Substring Input (+). See [Component Locations](#) for PV input location.

2017 and 2020 NEC Compliant Systems

For NEC 2017 and 2020 NEC compliant systems, connect the string PV modules in a series using one Generac SnapRS device per module.

NOTE: Install SnapRS devices prior to securing PV modules to the racking.

To install SnapRS devices:

1. See [Figure 5-4](#). Connect one SnapRS device (C) to the negative (-) lead of each PV module (D).
2. Connect the modules in series with the SnapRS devices installed in-line between modules by connecting the positive lead of each module to the SnapRS device already installed on the negative lead of the next PV module in the series.
3. Connect the PV string positive lead to PV Link (B) at the location marked PV Substring Input + (F). See [Component Locations](#) for more information.

4. Connect the PV string negative lead with its connected SnapRS device to PV Link (B) at the location marked PV Substring Input - (E). See [Component Locations](#) for more information.
5. Secure the SnapRS devices to the racking or module frame using zip ties or a similar fastener.
6. Make a string map using the PV Link peel-and-stick serial number stickers and record in [Table 1: Generac PV Link Important Information](#) the following information:
 - Each Generac PV Link serial number
 - Each Generac PV Link RCP number
 - Number of parallel strings
 - SnapRS devices per string
 - SnapRS DoM

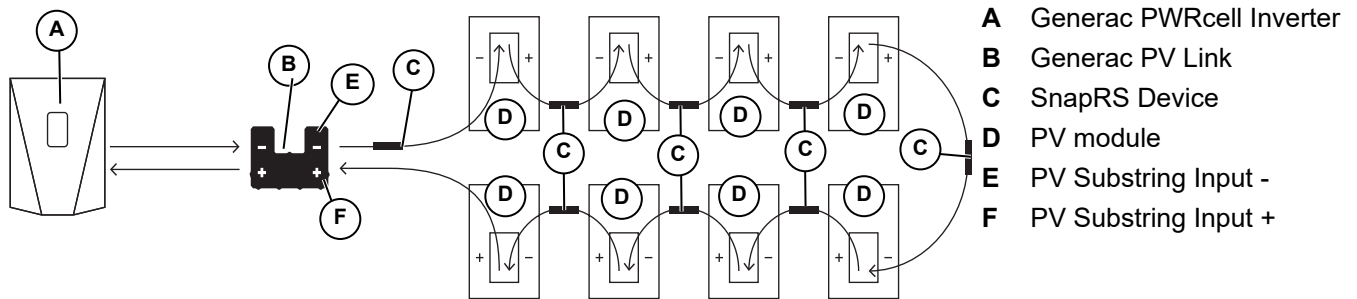

010028

Figure 5-4. Single-String PV Array with Generac SnapRS™ Device

NOTE: See [Figure 5-5](#). When dual strings are connected in parallel, each string must use the same number of the same type of PV modules, and there must be one SnapRS device for each module in the array.

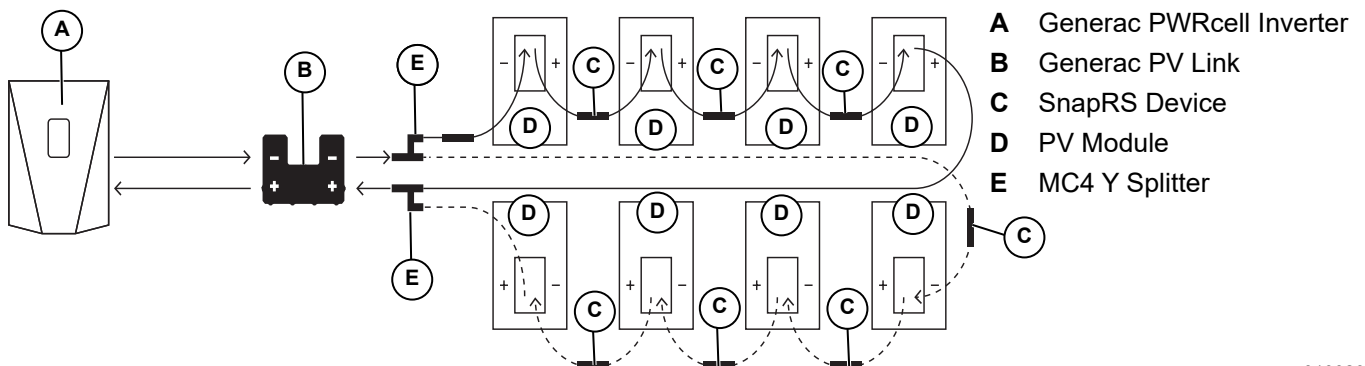

010029

Figure 5-5. Parallel-Input PV Array with Generac SnapRS™ Devices

This page intentionally left blank.

Section 6: Operating Instructions

User Interface via Inverter

Generac PV Link Information and control features are available on the Generac PWRcell Inverter control panel when REbus is energized. See the Generac PWRcell Inverter Owner's Manual for more information.

See [Figure 6-1](#). To access the device page for each PV Link, use left or right arrow buttons (A) on the inverter control panel to scroll through the pages. When on a PV Link device page, press center button (B) to enable or disable the device or to modify settings. The disabled/enabled state does not affect communication with the inverter.

NOTE: The PV Link only produces power after the REbus DC nanogrid has been established and the device has been enabled.

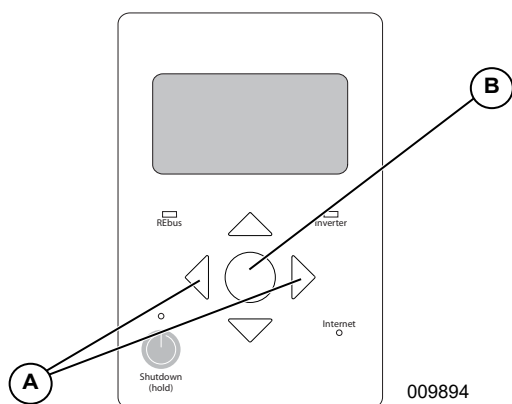

Figure 6-1. Inverter Control Panel

Commissioning the REbus System

The PV Link ships from the factory in a disabled state. Each unit must be enabled from the Generac PWRcell Inverter control panel. Once enabled, the PV Link automatically detects the REbus nanogrid and begins to export power when the bus is within normal operating specifications.

See the Generac PWRcell Inverter Installation Manual for instructions on commissioning the REbus system.

PVRSS Commissioning with SnapRS Devices

To enable PV Link to work as a PVRSS with SnapRS devices:

1. Press the right arrow button on the control panel repeatedly until the device page appears.

NOTE: The device page display should read Disabled. If it does not read Disabled, press the center button and disable the device.

2. See [Figure 6-2](#). Press the center button and select Mod. Settings to access device settings and options.
3. Record the RCPn number in [Table 1: Generac PV Link Important Information](#), found on the front cover of this manual.

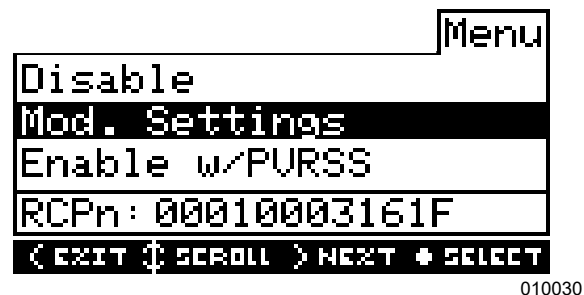

Figure 6-2. PVRSS Commissioning (1 of 4)

4. See [Figure 6-3](#). If installing a dual string array, select Mod. Settings and update the String Count value to 2.



Figure 6-3. PVRSS Commissioning (2 of 4)

5. See [Figure 6-4](#). Press the center button and select Enable w/PVRSS to enter the Testing PVRSS state.

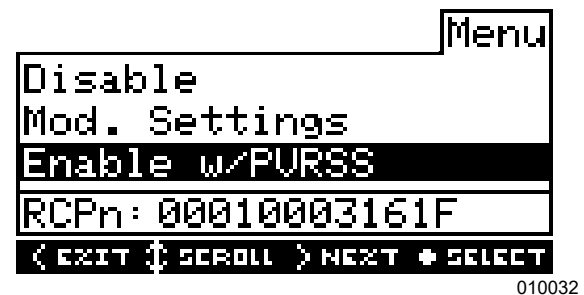
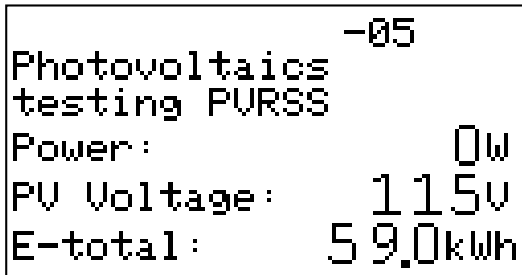

Figure 6-4. PVRSS Commissioning (3 of 4)

6. See **Figure 6-5**. The LCD will display Testing PVRSS during the testing process. Upon completion, the LCD will read Low Sun or Making Power, depending upon available PV voltage.



010033

Figure 6-5. PVRSS Commissioning (4 of 4)

7. Complete steps 1-4 for each PV link in the system.

NOTE: To verify a PV Link is working properly, navigate to the Mod.Settings page and confirm the SnapRSInstalld value matches the number of SnapRS devices connected to that PV Link.

PVRSS Commissioning Troubleshooting

If the device fails to commission properly an error message will indicate the source of the failure. See **Table 6-1: PVRSS Commissioning Troubleshooting** for common error codes and their meaning.

Table 6-1. PVRSS Commissioning Troubleshooting

Message	Cause	Solution
PVRSS fail: high input	The voltage detected with SnapRS devices disabled is higher than expected.	<ul style="list-style-type: none"> Verify the SnapRS devices are installed correctly. Run the PVRSS self-test. SnapRS devices have not been installed or have failed. <p>If the failure persists, contact the nearest Independent Authorized Service Dealer (IASD) or Generac Customer Service at 1-888-436-3722 (1-888-GENERAC), or visit www.generac.com for assistance.</p>
PVRSS not configured	PVRSS is enabled on the optimizer, but the SnapRSInstalld device setting indicates no SnapRS devices are installed.	<ul style="list-style-type: none"> Follow the instructions in the PVRSS Commissioning with SnapRS Devices section. See PVRSS Commissioning with SnapRS Devices. <p>If the failure persists, contact the nearest Independent Authorized Service Dealer (IASD) or Generac Customer Service at 1-888-436-3722 (1-888-GENERAC), or visit www.generac.com for assistance.</p>
PVRSS count mismatch	The number of SnapRS devices listed in the SnapRSInstalld device setting does not match the detected number of SnapRS devices.	<ul style="list-style-type: none"> Check the Mod. Settings and update the SnapRSInstalld value to reflect the number of installed SnapRS devices. <p>If the error persists, contact the nearest Independent Authorized Service Dealer (IASD) or Generac Customer Service at 1-888-436-3722 (1-888-GENERAC), or visit www.generac.com for assistance.</p>
PVRSS fail: low input	The panel output voltage is too low to accurately count the SnapRS devices.	<p>If this error occurs with normal exposure to sunlight, contact the nearest Independent Authorized Service Dealer (IASD) or Generac Customer Service at 1-888-436-3722 (1-888-GENERAC), or visit www.generac.com for assistance.</p>

Disabling PV Link

IMPORTANT NOTE: Disabling a PV Link does NOT de-energize the PV array if SnapRS devices are not installed. If SnapRS devices are installed, in-array voltages are limited to less than 80 VDC.

IMPORTANT NOTE: Disabling PV Link does not de-energize the DC bus if other devices are providing power to the DC bus.

IMPORTANT NOTE: The disabled/enabled state of each PV Link persists through AC power outages and DC bus power cycling.

To disable a PV Link:

1. On the Generac PWRcell Inverter control panel, use the left or right arrows to scroll to the page for the desired PV Link.
2. Press the center button to enter device settings.
3. Use the up and down arrows to highlight Disable and press the center button to select.
4. Arrow right and press the center button to Confirm.
5. Repeat steps 1–4 to disable any additional optimizers in the system.

NOTE: Repeat the process to re-enable each optimizer.

AFD Self-Test

NOTE: Arc fault detection is always enabled.

Performing an arc fault detection (AFD) self-test confirms arc fault functionality is working properly. When an arc fault is detected, the status message reads Arc Fault.

To conduct an AFD test:

1. On the Generac PWRcell Inverter control panel, use the left or right arrows to scroll to the page for the desired PV Link.
2. Press the center button to enter device settings.
3. Use the up and down arrows to highlight Test AFD and press the center button to enter the test state.
4. Arrow right and press the center button to Confirm

Upon test completion, the control panel will display a result of Test Success or Test Failure. After a few seconds, the AFD test will automatically clear.

PVRSS Self-Test

After commissioning, you can verify proper function and configuration of the PVRSS system at any time by manually running the PV Link PVRSS self-test.

To run the PVRSS self-test:

1. On the Generac PWRcell Inverter control panel press the right arrow button repeatedly until the first PV Link device page appears.

NOTE: The device page display should read Disabled. If it does read not Disabled, press the center button and Disable the PV Link.

2. Press the center button and select Test PVRSS. to enter the Testing PVRSS state.

The display indicates Testing PVRSS during the test process, which can take up to three minutes. Upon successful completion, the display will read: Test Success.

This page intentionally left blank.

Section 7: Maintenance

WARNING

Equipment damage. Never open Generac PV Link. The optimizer is factory-sealed and contains no field-serviceable parts. Opening the optimizer could result in equipment damage.

(000655)

Maintenance

See **Figure 7-1**. To ensure maximum performance, keep heatsink fins (A) free of leaves and other debris.

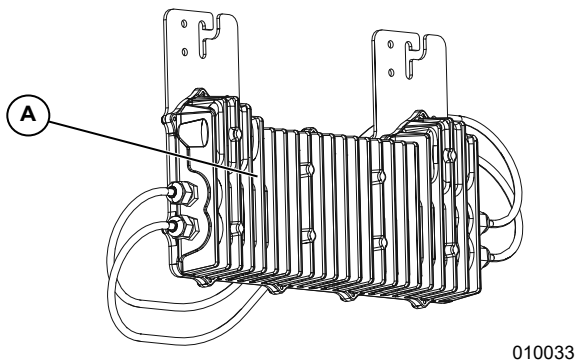

Figure 7-1. Heatsink Fins

The PV Link does not require regular maintenance and contains no user-serviceable parts.

Service

If the PV Link is not operating as expected, or if a PV Link error message appears on the Generac PWRcell Inverter control panel LCD display, contact the nearest Independent Authorized Service Dealer (IASD) or Generac Customer Service at 1-888-GENERAC (1-888-436-3722), or visit www.generac.com for assistance.

This page intentionally left blank.

This page intentionally left blank.

This page intentionally left blank.

Part No. DMAN00013 Rev. A 09/30/19
©2019 Generac Power Systems, Inc.
All rights reserved.
Specifications are subject to change without notice.
No reproduction allowed in any form without prior written
consent from Generac Power Systems, Inc.

GENERAC®



Generac Power Systems, Inc.
S45 W29290 Hwy. 59
Waukesha, WI 53189
1-888-GENERAC (1-888-436-3722)
www.generac.com