

ANALYTIC SYSTEMS

Power Conversion Solutions

INSTALLATION & OPERATION MANUAL

**BCA1050/1550
BATTERY CHARGERS**

**PWS1050/1550
POWER SUPPLIES**



An ISO9001 Registered Company Battery Chargers • Inverters • Power Supplies • Voltage Converters

101-8128 River Way, Delta B.C. V4G 1K5 Canada T. 604.946.9981 F. 604.946.9983 TF. 800.668.3884 (US/CANADA)

www.AnalyticSystems.com



ANALYTIC SYSTEMS
Power Conversion Solutions

Copyright (2005-2020) Analytic Systems Ware (1993) Ltd.

Revised - May 11, 2020

BCA/PWS/1050/1550

IMPORTANT SAFETY INSTRUCTIONS

SAVE THESE INSTRUCTIONS — This manual contains important safety and operating instructions for the battery charger.

GENERAL PRECAUTIONS

1. Do not expose the unit to rain or snow unless it is a sealed model.
2. Use of an attachment not recommended or sold by the manufacturer may result in a risk of fire, electric shock, or injury to persons.
3. Do not disassemble the battery charger; return it to the manufacturer or an authorized service center when service or repair is required. Incorrect reassembly may result in a risk of electric shock or fire. Voltages in excess of 350 volts are present inside the charger anytime it is plugged into an AC outlet, even if it is switched off.
4. To reduce risk of electric shock, unplug the battery charger from the AC outlet before attempting any maintenance or cleaning. Turning off controls will not reduce this risk.
5. Never place battery charger directly above battery; gases from battery will corrode and damage battery charger.
6. Never allow battery acid to drip on the battery charger.

BATTERY SAFETY

1. WARNING — RISK OF EXPLOSIVE GASES
 - i. WORKING IN VICINITY OF A LEAD-ACID BATTERY IS DANGEROUS. BATTERIES GENERATE EXPLOSIVE GASES DURING NORMAL BATTERY OPERATION. FOR THIS REASON, IT IS OF UTMOST IMPORTANCE THAT EACH TIME BEFORE SERVICING EQUIPMENT IN THE VICINITY OF THE BATTERY, YOU READ THIS USER GUIDE AND FOLLOW THE INSTRUCTIONS EXACTLY.
 - ii. To reduce risk of battery explosion, follow these instructions and those published by the battery manufacturer and manufacturer of any equipment you intend to use in vicinity of battery. Review the cautionary marking on these products.
2. PERSONAL PRECAUTIONS
 - i. Someone should be within range of your voice or close enough to come to your aid when you work near a battery.
 - ii. Have plenty of fresh water and soap nearby in case battery acid contacts skin, clothing, or eyes.
 - iii. Wear complete eye protection and clothing protection. Avoid touching eyes while working near battery.
 - iv. If battery acid contacts skin or clothing, wash immediately with soap and water. If acid enters eye, immediately flood eye with running cold water for at least 10 minutes and get medical attention immediately



- v. NEVER smoke or allow a spark or flame in the vicinity of a battery.
- vi. Be extra cautious to reduce risk of dropping a metal tool onto battery. It might spark or short-circuit the battery or other electrical part that may cause a fire or explosion.
- vii. Remove personal metal items such as rings, bracelets, necklaces, and watches when working with a lead-acid battery. A lead-acid battery can produce a short-circuit current high enough to melt metal, causing a severe burn.
- viii. NEVER charge a frozen battery.
- ix. If it is necessary to remove a battery from service, always remove grounded terminal from battery first. Make sure all accessories connected to the battery are off, to prevent an arc when reconnecting the new battery.
- x. Be sure area around battery is well ventilated.
- xi. Clean the battery terminals. Be careful to keep corrosion from coming in contact with eyes.
- xii. Study all the battery manufacturer's specific precautions such as removing or not removing cell caps while charging and recommended rates of charge

GROUNDING AND AC POWER CORD CONNECTION INSTRUCTIONS

The plug must be plugged into an outlet that is properly installed and grounded in accordance with all local codes and ordinances.

DANGER: Never alter the AC power cord or plug provided. If it will not fit the output, use an approved adapter or have the proper AC power cord installed by a qualified electrician. Improper connection can result in the risk of electric shock.

MEDICAL EQUIPMENT NOTICE

Analytic Systems does not recommend the use of their products in life support applications where failure or malfunction of this product can be reasonably expected to cause failure of the life support device or to significantly affect its safety or effectiveness. Analytic Systems does not recommend the use of any of its products in direct patient care. Examples of devices considered to be life support devices are neonatal oxygen analyzers, nerve stimulators (whether used for anesthesia, pain relief, or other purposes), auto-transfusion devices, blood pumps, defibrillators, arrhythmia detectors and alarms, pacemakers, hemodialysis systems, peritoneal dialysis systems, neonatal ventilator incubators, ventilators for both adults and infants, anesthesia ventilators, and infusion pumps as well as any other devices designated as "critical" by the U.S. FDA.



TABLE OF CONTENTS

- Front Cover, Product Photo and Title
- Product Warning and Advisories
- Table of Contents
- Introduction
- Front Panel Configurations
- Battery Charger Operation
- Power Supply Operation
- Installation
- AC Input Connection
- DC Output Connection
- Battery Temperature Sensors
- Equalize Cycle
- Product Options
- Troubleshooting
- Specifications
- Warranty



ANALYTIC SYSTEMS
Power Conversion Solutions

Copyright Analytic Systems Ware (2020) Ltd.

Revised - June 4, 2020



Introduction

The 1050/1550 family of COTS AC-source battery chargers (BCA) and power supplies (PWS) are designed to supply a DC load or charge a battery at 12, 24, 32, 36, 48 or 72 (Rail) VDC. The 1050 family provides up to 1000 watts of precision power, while the 1550 family can supply up to 1550 watts. These 1050 and 1550 families are identical to their previous models (1005 and 1505, respectively) in form, fit, and function and is a direct drop in replacement for their predecessors.

Internally, the recently updated design incorporates a brand new Power Factor Corrected (PFC) Input Stage. The PFC input stage increases the efficiency over the previous auto-switching technology and eliminates the dead spot between 110 and 220 VAC input allowing the power supply to run continuously from 90 – 264 VAC In at 45 – 65 Hz. Additionally, heavy input and output filtering reduce EMI to extremely low levels to prevent radio interference.

These units are constructed from heavy-duty anodized extruded and billet machined aluminum and all stainless steel fasteners for rugged duty. These units feature a variety of optional environmental upgrades including IP66 rated construction for service in marine environments (IP67-rated construction with certification and testing also available). Additionally military ruggedization upgrades are also available including MIL-spec connectors, expanded operating temperature and shock and vibration protection.

Reliability features include an LED status indicator panel, input circuit breaker, thermal shutdown, current limiting, reverse polarity connection protection and output short circuit shutdown with automatic recovery.



Front Panel Configurations

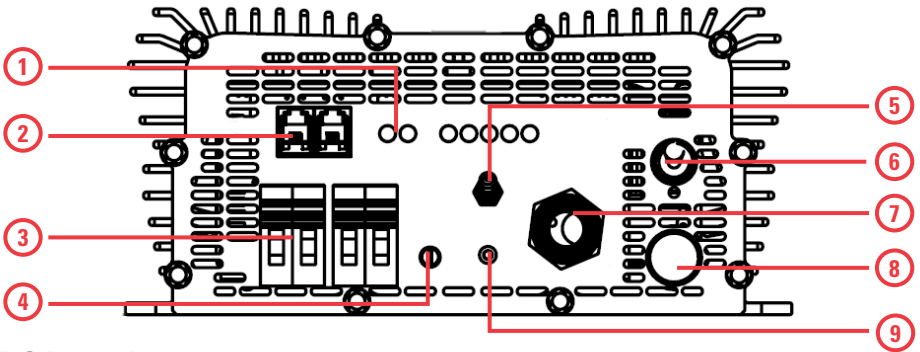

BCA1050/1550

- | | |
|---|--|
| <ol style="list-style-type: none"> 1. Indicator LEDs 2. Battery Temperature Sensor
Connection: 2x RJ45 'telephone jack' connector 3. DC Output Connection: 2x Color-coded Phoenix VDFK6 terminal blocks 4. Output Voltage Adjust | <ol style="list-style-type: none"> 5. Stage Select Switch 6. Power Switch 7. AC Input Connection: 3 m / 9.8ft 3xAWG14 power cord with NEMA 5-15 or CEE 7/VII plug 8. Input Fuse 9. Equalize Start button |
|---|--|

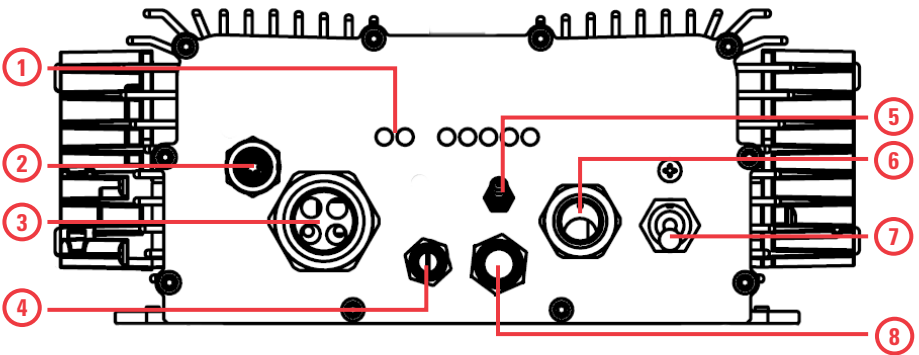

BCA1050W/1550W

- | | |
|--|---|
| <ol style="list-style-type: none"> 1. Indicator LEDs 2. Battery Temperature Sensor
Connection: 4-pin socket panel mount, ConXall Micro-Con-X, 17882-4SG-300 connector 3. DC Output Connection: 4x color-coded flying input leads encased in a watertight Sealcon gland | <ol style="list-style-type: none"> 4. Output Voltage Adjust 5. Stage Select Switch 6. Power Switch 7. AC Input Connection: 3 m / 9.8ft 3xAWG14 power cord with NEMA 5-15 or CEE 7/VII plug 8. Equalize Start button |
|--|---|



Front Panel Configurations

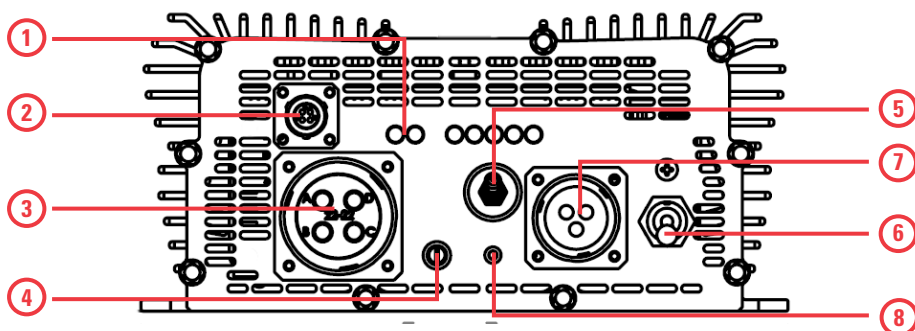

BCA1050M/1550M

- | | |
|--|---|
| <ol style="list-style-type: none"> 1. Indicator LEDs 2. Battery Temperature Sensor
Connection: Amphenol 4-hole Circular MIL-Spec PT02A-8-4S 3. DC Output Connection: Amphenol GTC02R22-22S-RDS 4-hole MIL-Spec connector 4. Output Voltage Adjust | <ol style="list-style-type: none"> 5. Stage Select Switch 6. Power Switch 7. AC Input Connection: Amphenol 3-pin Circular MIL-spec GTS02R16-10P connector 8. Equalize Start button |
|--|---|

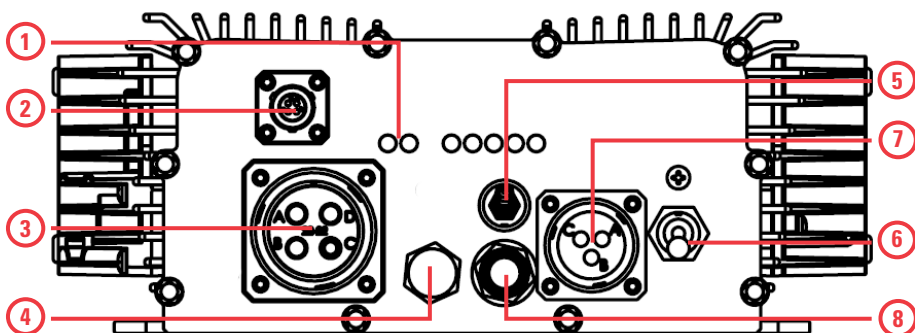

BCA1050MW/1550MW

- | | |
|---|---|
| <ol style="list-style-type: none"> 1. Indicator LEDs 2. Battery Temperature Sensor
Connection: Amphenol 4-hole Circular MIL-Spec PT02A-8-4S 3. DC Output Connection: Amphenol GTC02R22-22S-RDS 4-hole MIL-Spec connectors | <ol style="list-style-type: none"> 4. Output Voltage Adjust 5. Stage Select Switch 6. Power Switch 7. AC Input Connection: Amphenol 3-pin Circular MIL-spec GTS02R16-10P connector 8. Equalize Start button |
|---|---|

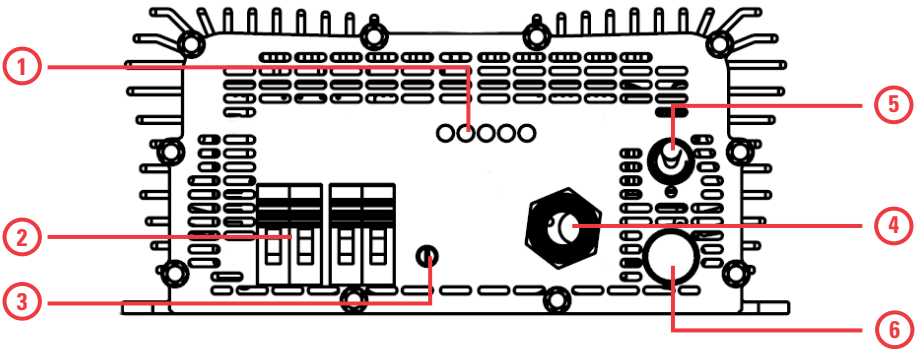

PWS1050/1550

- | | |
|--|--|
| <ol style="list-style-type: none"> 1. Indicator LEDs 2. DC Output Connection: Color-coded Phoenix VDFK6 terminal blocks 3. Output Voltage Adjust | <ol style="list-style-type: none"> 4. AC Input Connection: 3 m / 9.8ft 3xAWG14 power cord with NEMA 5-15 or CEE 7/VII plug 5. Power Switch 6. Input Fuse |
|--|--|

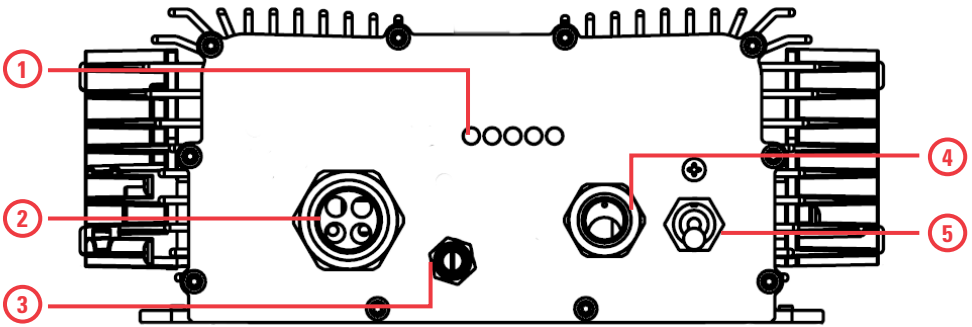

PWS1050W/1550W

- | | |
|---|---|
| <ol style="list-style-type: none"> 1. Indicator LEDs 2. DC Output Connection: 4x color-coded 8AWG flying input leads encased in a watertight Sealcon gland 3. Output Voltage Adjust | <ol style="list-style-type: none"> 4. AC Input Connection: 3 m / 9.8ft 3xAWG14 power cord with NEMA 5-15 or CEE 7/VII plug 5. Power Switch |
|---|---|

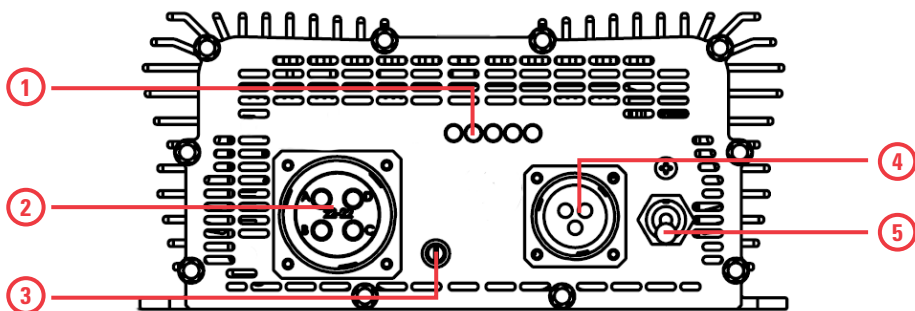

PWS1050M/1550M

- | | |
|--|---|
| <ol style="list-style-type: none"> 1. Indicator LEDs 2. DC Output Connection: Amphenol GTC02R22-22S-RDS 4-hole MIL-Spec connector 3. Output Voltage Adjust | <ol style="list-style-type: none"> 4. AC Input Connection: Amphenol 3-pin Circular MIL-spec GTS02R16-10P connector 5. Power Switch |
|--|---|

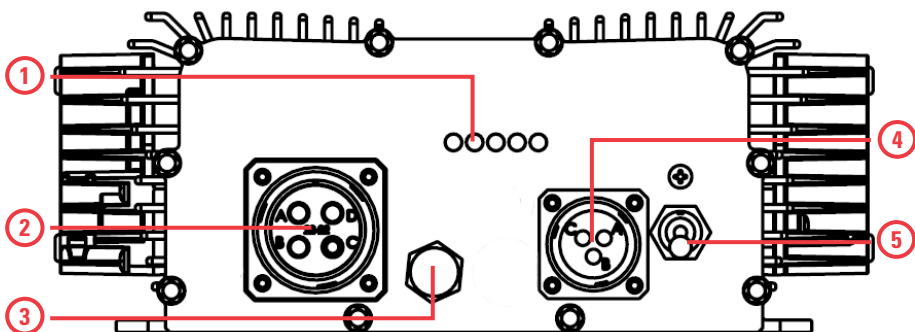

PWS1050MW/1550MW

- | | |
|--|---|
| <ol style="list-style-type: none"> 1. Indicator LEDs 2. DC Output Connection: Amphenol 4-hole Circular MIL-spec GTC02R22-22S-RDS connectors 3. Output Voltage Adjust | <ol style="list-style-type: none"> 4. AC Input Connection: Amphenol 3-pin Circular MIL-spec GTS02R16-10P connector 5. Power Switch |
|--|---|



Battery Charger Operation (BCA)

The BCA1050/BCA1550 series battery chargers are designed for simple and intuitive operation. Before operating, make sure this unit is properly installed and connected. See *Installation* for more information.

TO CHARGE A BATTERY

1. Select the type of charging profile using the Stage Select switch on the front panel. See *Charging Profiles* for more information.
2. Move the Power Switch to ON. The alarm buzzer will sound and the LOW VOLTAGE OUTPUT LED will glow red briefly, then the POWER LED will glow green.
3. The CHARGING LED will glow green and the unit will charge the battery at the voltage and current listed on the label.
4. Once the battery is fully charged, the CHARGING LED will turn off. The unit will maintain the battery at full charge for as long as it is connected.

TO ADJUST THE CHARGING (FLOAT) VOLTAGE

The Output Voltage Adjust can be use to adjust the charging (float) voltage $\pm 1.0V$ from the unit's rated output voltage in order to fine-tune its charging capabilities.

1. On W-series and Y-series models the Output Voltage Adjust is protected by an O-ring sealed hexagonal plug. This plug can be removed using a 5/8ths inch or 16mm wrench.
2. Move the Power Switch to ON.
3. Rotate the output voltage adjustment potentiometer on the front panel.
4. Rotating the potentiometer clockwise increases the output voltage; counterclockwise decreases it.
5. Using a voltmeter or multimeter, check the charging voltage at the Output Connection. Adjust until the voltage reading is suitable. If the unit has the optional digital meter, that can be used to read the output voltage instead.
6. Replace the hexagonal plug to return the unit to water resistant condition.

TO END OPERATION

1. Move the Power Switch to OFF.
2. Wait for all the LEDs stop glowing.
3. Once all of the LEDs are off, it is safe to disconnect the unit from the power source and battery. The unit is now ready for storage or service.



Power Supply Operation (PWS)

The PWS1050/PWS1550 series power supplies are designed for simple and intuitive operation. Before operating the unit, it must be properly installed and connected. See *Installation* for more information.

TO POWER A LOAD

1. Move the Power Switch to ON. The alarm buzzer will sound and the LOW VOLTAGE OUTPUT LED will glow red briefly, then the POWER LED will glow green.
2. The POWER LED will glow green and the unit will charge the battery at the voltage and current listed on the label.

TO ADJUST THE OUTPUT VOLTAGE

The Output Voltage Adjust can be used to adjust the charging (float) voltage $\pm 1.0V$ from the unit's rated output voltage in order to fine-tune its charging capabilities.

1. On W-series and Y-series models the Output Voltage Adjust is protected by an O-ring sealed hexagonal plug. This plug can be removed using a 5/8ths inch or 16mm wrench.
2. Move the Power Switch to ON.
3. Rotate the output voltage adjustment potentiometer on the front panel.
4. Rotating the potentiometer clockwise increases the output voltage; counterclockwise decreases it.
5. Using a voltmeter or multimeter, check the voltage at the Output Connection. Adjust until the voltage reading is suitable. If the unit has the optional digital meter, that can be used to read the output voltage instead.
6. Replace the hexagonal plug to return the unit to water resistant condition.

TO END OPERATION

1. Move the Power Switch to OFF.
2. Wait for all the LEDs stop glowing.
3. Once all of the LEDs are off, it is safe to disconnect the unit from the power source and battery. The unit is now ready for storage or service.



Operational Indicators

This unit features seven indicator LEDs on its front panel to display the unit's operating condition. The meanings of these LEDs are detailed below. For more information on the LEDs relating to alarm conditions, see *Troubleshooting*.

BCA ONLY LEDS

EQUALIZE [1]

THE BATTERY TEMPERATURE SENSOR MUST BE INSTALLED TO USE THIS FUNCTION

This LED glows red when the unit is performing an Equalize cycle. This LED blinks red when the unit is waiting for a battery to finish charging before performing an Equalize cycle.

BATTERY OVER TEMP [2]

THE BATTERY TEMPERATURE SENSOR MUST BE INSTALLED TO USE THIS FUNCTION.

This LED glows red when the battery's temperature is above the safe limit, the unit will then turn OFF its outputs as precaution. Once the battery temperature is within the safe operating range, the unit will automatically resume operation

STANDARD LEDS

POWER ON [3]

This LED glows green when the unit is connected to an AC power source and turned ON.

CHARGING[4]

This LED glows green when the unit is currently charging a battery. This LED turns off when the connected battery is fully charged. The charger will maintain the battery at the float voltage for as long as it is connected.

OVERTEMP [5]

This LED glows red when the unit's internal temperature is above the safe limit, the unit will then turn OFF its outputs as a precaution. Once the internal temperature is within the safe operating range, the unit will automatically resume operation.

LOW VOLTAGE OUTPUT [6]

This LED glows red when the output voltage is too low to properly charge the battery, the unit will then turn OFF its outputs as a precaution. Once the unit detects the output voltage is within the normal operating range, it will automatically resume operation.

LOW VOLTAGE INPUT [7]

This LED glows red when the input voltage is too low for proper operation, the unit will then turn OFF its outputs as a precaution. Once the unit detects the input voltage is within the normal operating range, it will automatically resume operation.



Installation

MOUNTING

All 1050 and 1550 units weigh approximately 20lbs (9.1 kg) and can be safely mounted on either a horizontal or vertical surface. Mount the unit in a dry and well ventilated location at least 1 inch (2.54 cm) surrounding clearance.

The W-series models are designed to meet IP66 rating, and is resistant to water spray from any direction. These units can be mounted in wet locations but are not suitable for submersion. The Y-series models are designed and certified to meet IP67 rating.

These units are resistant to water immersion of a depth up to 1 meter for 30 minutes and suitable for mounting in locations such as a vehicle fording a river.

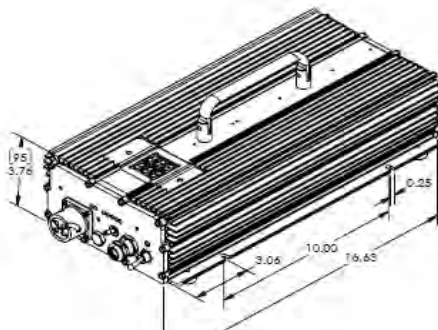

CAUTION: NEVER CONNECT OR DISCONNECT ANYTHING TO THE UNIT'S INPUT OR OUTPUT WHILE IT IS ON!

To prevent the risk of high voltage electric shock, never connect or disconnect anything to/from the unit's input or output connections while the power switch is ON.

GROUNDING

The unit case is connected to AC Ground and AC Neutral in order to meet regulatory requirements and reduce the possibility of it generating any radio frequency interference.

The unit case must be bonded appropriately to the grounding system of the vehicle or marine vessel. On a vehicle, bond the case to the vehicle's frame. On a marine vessel, bond the case to the vessel's hull. A grounding stud is provided on the front panel for this purpose.

To ensure proper grounding, check the connection with an ohmmeter. The case is isolated from the DC input, so the DC power can be connected to a different ground from the AC output.

DISCONNECTING

If you need to disconnect the unit for service or storage:

1. Move the power switch to OFF and disconnect the power source and load
2. With power disconnected, move the power switch to ON.
3. Leave the switch in this position for one minute to discharge the storage capacitors.
4. Return the power switch to the OFF position.
5. The power supply or battery charger is ready for service or storage.



AC Input Connection

The AC Input connection is intended for connection to the AC power source that is powering the battery charger or power supply. All 1050 and 1550 units feature Power Factor Correction technology on the input and can operate from any AC input voltage from 90-264 VAC.

Some units may require wiring to this connection. To determine suitable wiring, the rated input voltage and current values can be found on the unit label located on the **XXX** panel. For more information, regarding input power specifications, see the *Specifications* section.

1050/1550/1050W/1550W

Regular and W-series BCA and PWS units are equipped with a 1.0m/3.0ft power cord ending in a NEMA 5-20 plug connector (for North American models) or a CEE7/7 plug connector (for European models) to serve as an AC Input Connection.

To hard wire this connection a source of power, cut the plug off the wire, and strip the wires inside as necessary. The wire colors are as follows:

NA Mains		European Union Mains	
Black	AC Hot	Brown	AC Hot / Phase 1
White	AC Neutral	Blue	AC Neutral / Phase 2
Green	Ground	Green/Yellow	Ground

1050M/1550M/1050MW/1550MW

M-series and MW-series BCA and PWS units are equipped with a 3-pin Amphenol circular MIL-Spec connector to serve as an AC Input Connection. See *Specifications* for more information regarding suitable mating connectors. This connector's wiring pin-out can be found on the front panel label and is as follows:

Pin	Polarity
Pin A	AC Live/Hot
Pin B	AC Neutral
Pin C	AC Ground



DC Output Connection

The DC Output Connection is intended for connection to the batteries being charged or DC load being powered by the battery charger or power supply, respectively. To ensure normal operation, the total average connected load should not exceed the unit's output amps rating.

Some units may require wiring to this connection. To determine suitable wiring, the rated output voltage and current values can be found on the unit label located on the **XXX** panel. For more information, regarding output power specifications, see the *Specifications* section.

TIP: WHEN CHARGING MULTIPLE BATTERIES OR POWERING MULTIPLE LOADS, THEY MUST SHARE A COMMON GROUND.

CAUTION: NEVER CONNECT THE LOAD OR BATTERY IN REVERSE POLARITY!!

This will activate the reverse polarity connection protection which will blow the internal output fuses in order to protect the device. The unit will be inoperable until these fuses have been replaced. See *Output Fuse Replacement* for more information.

CAUTION: NEVER USE A POWER SUPPLY UNIT TO CHARGE A BATTERY!!

PWS power supply units do not have the necessary circuitry on the output to prevent current from back-feeding into the unit. Using a power supply to charge a battery will damage the unit and is not covered under the Warranty.

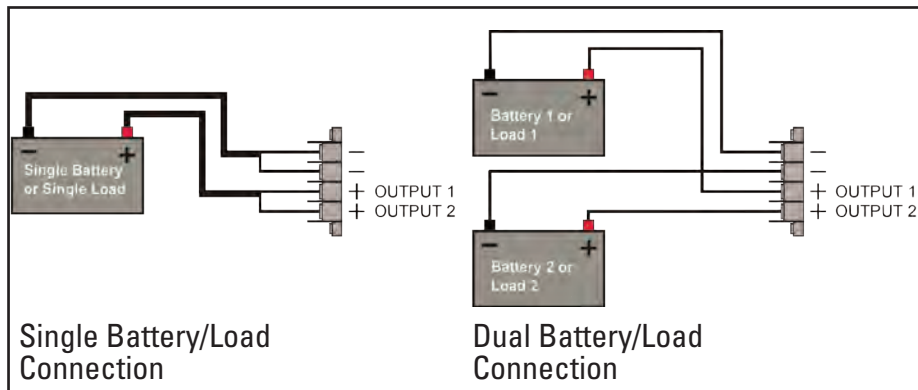

IMPORTANT: 12 VOLT OUTPUT BATTERY CHARGER AND POWER SUPPLY UNITS WILL ONLY SUPPORT SINGLE BATTERY/LOAD CONNECTION.



1050/1550

Base BCA and PWS units are equipped with two sets of Phoenix VDFK terminal block connectors to serve as a DC Output Connection. This polarity of this connection can be found on the front panel label and is also as follows:

Connector Color	Polarity
Black	Negative
Red	Output Positive

1050W/1550W

W-series and Y-series BCA and PWS units are equipped with two sets color-coded flying 8AWG input leads encased in a watertight Sealcon gland to serve as a DC Output Connection. This polarity of this connection can be found on the front panel label and is also as follows:

Wire Color	Polarity
Black	Negative
Red	Output Positive

1050M/1550M/1050MW/1550MW

M-series and MW-series BCA and PWS units are equipped with a Amphenol GTC02R22-22S-RDS 4-hole MIL-Spec connectors DC Output Connection. The wiring for this connection can be found on the front panel label and is as follows:

Pin	Polarity
Pin A	Output Positive 1
Pin B	Output Positive 2
Pin C	Negative
Pin D	Negative



Battery Temperature Sensor (BCA Only)

This unit is supplied with one battery temperature sensor. The sensor communicates the temperature of the battery to the battery charger and is necessary for the charger's voltage temperature compensation, battery over temperature shutdown and equalize cycle functions.



Pictured: An *Analytic Systems* waterproof battery temperature sensor (Product:B-TEMPW)

BATTERY TEMPERATURE SENSOR CONNECTION

This unit is equipped with an Amphenol MIL-Spec PT02A8-4S connector to connect to up to two *Analytic Systems* waterproof battery temperature sensors. This connection's pinout can be found on the unit label.

TO INSTALL THE SENSOR AT THE BATTERY:

- Slide the sensor flush between the side of the battery and wall of the battery platform.
- Place the battery on top of the sensor to hold it in place.
- Apply a small amount of silicone RTV sealant to the sensor and stick it to the top of the battery.

There are multiple ways to install the sensor at the battery. Regardless of which method you use, the sensor must be firmly secured and should not lose physical contact with the battery at any point in the charging cycle.

VOLTAGE TEMPERATURE COMPENSATION

Heat is a normal by-product of the charging cycle. However, excessive heat can cause overcharging, damaging the battery. With a battery temperature sensor installed, the battery charger will automatically reduce the charging voltage to compensate for rising temperature.

The ambient battery temperature is pre-set to 77°F (25°C). For each degree above 77°F (25°C), the charger will reduce the charging voltage by a small amount. See *Specifications* for more information regarding, the default temperature compensation coefficient of your unit. You can change the voltage temperature compensation coefficient and set its operating thresholds using *Analytic Systems'* free-to-download software PowerWizard.



Equalize Cycle (BCA Only)

If a battery is left discharged for too long, sulfate crystals can form on its internal electrode plates. This interferes with their conductance reducing battery's capacity and charging speed.

Your battery charger can perform an Equalize Cycle to correct this condition. An Equalize Cycle ensures all the cells of the battery are fully charged; deliberately overcharging the battery at a low current (approximately 10% of its normal output) until it reaches the unit's programmed Equalize Voltage. The charger maintains the battery at that voltage for three hours after which time the Equalize Cycle ends and the battery charger resumes normal operation; maintaining the battery at the float voltage.

DANGER: AN EQUALIZE CYCLE CAN ONLY BE PERFORMED IN A WELL VENTILATED AREA!

Hydrogen gas is a normal by-product of the Equalize Cycle and is explosive at concentrations greater than 4% of the local atmosphere.

CAUTION: A BATTERY TEMPERATURE SENSOR MUST BE INSTALLED AND USED!

Heat is a normal by-product of the Equalize Cycle and excessive heat will damage the battery bank. The battery temperature sensor must be connected and installed to allow the unit to monitor the temperature and ensure it is within safe operating limits.

TO PERFORM AN EQUALIZE CYCLE:

1. Connect and install the supplied Analytic Systems Battery Temperature Sensor. See *Installation* for more information.
2. Push the Equalize Button on the front panel. On some units, this button is recessed to prevent accidental operation; a ballpoint pen can be used to access it.
3. If the unit is not currently charging a battery, the EQUALIZE LED will glow red and the Equalize Cycle will begin.
4. If the unit is currently charging a battery, the EQUALIZE LED will blink red. Once the charging cycle ends, the CHARGING LED will shut off and the EQUALIZE LED will glow red and the Equalize Cycle will begin.
5. Three hours later, the Equalize Cycle will end. The battery charger will automatically resume normal operation maintaining the battery at the float voltage.



Output Fuse Replacement

This unit features output reverse polarity connection protection. If a load or battery is connected to the output in reverse polarity, the output fuses will blow to protect the power supply or battery charger.

The unit is inoperable until the fuses are replaced. See the specifications section for rating and make fuses. When replacing the fuses, ALL the fuses must be replaced as they operate in parallel.

CAUTION: BEFORE REPLACING THE FUSES, DISCONNECT THE UNIT FROM THE POWER SOURCE AND MAKE SURE THE POWER SWITCH IS OFF.

To prevent risk of high voltage electric shock, the unit must be fully disconnected from power before attempting to replace the output fuses.

TO REPLACE THE FUSES:

1. Loosen and remove the ten screws holding the front panel to the chassis.
2. Gently pull the front panel free from the main circuit board. The output fuses are mounted in fuse holders on the front panel circuit board. Their location is indicated below.
3. Replace the old fuses with new fuses. The new fuses must be the same type and rating as the old ones. See *Specifications* for more information regarding output fuses.
4. The main circuit board connects to the front panel, via the black square shaped connectors above the fuses. Gently push the two together to seat them.
5. Make sure that any O-ring seals and gaskets are properly seated. This is very important for the W/Y models in order to maintain a water-tight seal!
6. Re-insert all the front panel screws loosely, making sure none are cross-threaded. Once all screws are started, tighten them in sequence. The screws are made from corrosion resistant stainless steel which is softer than regular steel, so take care to not over-tighten.
7. Reconnect the unit to power and check that it turns ON. Turn the unit OFF and then, making certain that the polarity is correct, reconnect the load or battery to the output. Turning the unit ON, normal operation should resume immediately.



Pictured: Front panel circuit board. Output fuse location indicated by red circle.



Charging Profiles (BCA Only)

This unit has both two-stage and three-stage charging capability. You can choose which type of charging is used during operation by using the Stage Select switch located on the **FRONT** panel. Below are explanations of the two charging profiles:

TWO-STAGE CHARGING

1. The battery is charged at constant current until the battery's voltage reaches the float voltage.
2. The charging current diminishes as necessary to maintain the battery at that voltage.
3. Once the current drops to 10%, the charging cycle is complete. The unit will maintain the battery at full charge until needed.

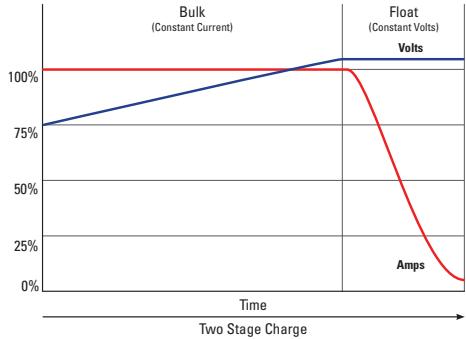

Two-stage charging is gentler on the battery since the battery is subjected to lower voltage and current than in three-stage. In addition, a reasonable load can be connected to the battery without affecting the charger's ability to keep the battery at full charge.

THREE-STAGE CHARGING

1. The battery is charged at constant current (higher than in two-stage) until the battery voltage reaches the absorption voltage.
2. Then the charging current diminishes as necessary to maintain the battery at that voltage.
3. Once the current drops to 10%, the charging cycle is complete. The unit switches to keeping the battery at the float voltage and will maintain the battery at full charge until needed.

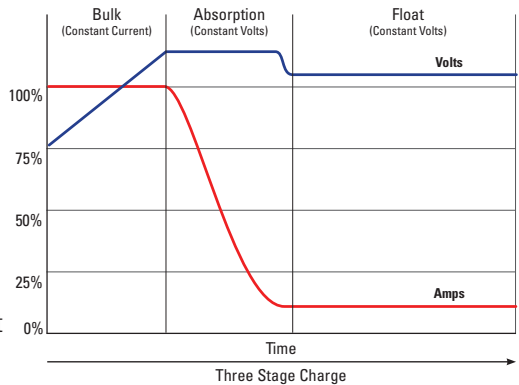

Three-stage charging is faster than two-stage, but the battery is subjected to higher voltage and current. Three-stage charging is not recommended for charging loaded batteries because the unit cannot differentiate between current going to a load connected to the battery and current being absorbed by the battery; which can cause overcharging.



Digital Meter Option

BCA and PWS units built with the V-Option (Digital Voltmeter Ammeter Display) features a bright and easy-to-read

This option adds approximately 3.0 in / 5.1 cm to the unit's chassis length with the handle fully upright (5.9 in / 15.0 cm total height)



Portable Option

BCA and PWS units built with the P-Option (Portable) feature a foldable carrying handle and rugged rubberized feet designed for easy hand transport and portable operation.

This option adds approximately 2.1 in / 5.1 cm to the unit's chassis height with the handle fully upright (5.9 in / 15.0 cm total height)





Remote Control Accessory



IMPORTANT: This remote can only be used on Battery Chargers manufactured by Analytic Systems.

The remote control panel and 9-pin D-connector are an optional feature for this product line. The remote control panel allows the unit to be operated remotely and duplicates all the diagnostic LED indicators with audible alarm. A built-in dimmer switch allows you to control the brightness of the remote control LEDs.

CAUTION: DO NOT CONNECT THE REMOTE CONTROL TO THE CHARGER WHILE IT IS ON!

To prevent the possibility of high voltage electrical shock, the charger must be OFF when connecting the remote control panel. Do not remove the protective dust-cover on the remote control port if it is not being used.

CAUTION: DO NOT CONNECT THIS PORT TO A COMPUTER!

This will cause serious damage to the battery charger and computer. This damage is not covered under the warranty.

Pin	Function
1	Dry Contact Relay (Closed for fault)
6	Dry Contact Relay (Closed for fault)
2	Remote Off (Short to 5 to turn unit OFF)
7	OverTemp (Low for fault)
3	UnderVolt In (Low for fault)
8	OverLoad (Low for fault)
4	UnderVolt Out (Low for fault)
9	+12 Volts
5	Common

DRY CONTACT RELAY

The relay is factory preset to fail when the LOW OUTPUT VOLT LED and alarm buzzer come on. Both normally open and normally closed contacts are available on the connector. If your system detects an alarm condition when the charger is operating normally, simply move the wire connected to Pin 1 of the dry contact terminal block to Pin 3, or vice versa as needed



Troubleshooting

This unit is fitted with LED indicators and an alarm buzzer to display and diagnose any problems in operation. In the event of a malfunction, the unit will sound the buzzer to alert you prior to shutting itself down. You should immediately check which LEDs are glowing to determine the cause of the alarm.

LED Indicator	Meaning
BATT. OVERTEMP	The temperature of the battery being charged is too high for safe charging.
FIX:	The battery may be defective or there may not be adequate ventilation to cool the battery. Check that the battery is not defective using a multimeter. If it is working correctly, reposition the battery for better air circulation.
OVERTEMP	The unit's internal temperature is too high for normal operation.
FIX:	The unit's cooling fans may have failed or there may not be adequate ventilation to cool the power supply/battery charger. Check that the cooling fans are still working; if they are not then the unit must be returned to an authorized service center for repair. If they are working correctly, remount the battery charger for better air circulation.
OVER LOAD	The output current has exceeded the peak rating for too long.
FIX:	Reduce the load on the power supply by disconnecting some devices from the output.
LOW VOLTAGE IN	The input voltage is detected to be too low for normal operation
FIX:	Check that the power source is properly rated for use for the battery charger. Check that the input wiring and connection are free of damage and corrosion. If all of the above are in proper working order, the cause is likely an internal component failure and the unit must be returned to an authorized service center for repair.
LOW VOLTAGE OUT	The output voltage is detected to be too low for normal operation
FIX:	The output current might be exceeding the unit's peak rating causing the output voltage to drop to try and maintain the current at that level. Check if the output current is above its maximum rating, using a multimeter. If it is, reduce the load connected to output. Check that the output wiring and connections are free of damage and corrosion. If all of the above are in proper working order, the cause is likely an internal component failure and the unit must be returned to an authorized service center for repair.



Input Specifications

ALL 1050 UNITS

Volts Actual	90-264 VAC in, 45-65 Hz
Maximum Input Amps	13.1 A (@ 90 VAC in)
Input Fuse (Circuit Breaker)	25 A Slow Blow Part # MDA25A
Input Ripple and Noise	<50 mV Peak to Peak
Frequency	45 - 65 Hz
Power Factor	>0.99 @ 50/60 Hz
Inrush Current	<13A @264 VAC from fully discharged

ALL 1550 UNITS

Volts Actual	90-264 VAC in, 45-65 Hz
Maximum Input Amps	20 A (@ 90 VAC in)
Input Fuse (Circuit Breaker)	25 A Slow Blow Part # MDA25A
Input Ripple and Noise	<50 mV Peak to Peak
Frequency	45 - 65 Hz
Power Factor	>0.99 @ 50/60 Hz
Inrush Current	<13A @264 VAC from fully discharged



Output Specifications

BCA1050, BCA1050W, BCA1050M, BCA1050MW							
Volts Nominal (VDC)	12	24	32	36	48	72 (rail)	72
Charging Amps (A)	80	40	30	27	20	15	13
Float Voltage (VDC)	13.5	27.2	36.3	40.8	54.4	72.5	81.6
Absorption Voltage (VDC)	14.4	28.8	38.4	43.2	57.6	76.8	86.4
Absorption to Float Switch (Amps)	6	3	3	2	2	1	1
Output Overvoltage Trip (VDC)	17.0 ±0.5	34.0 ±1.0	45.0 ±1.5	51.0 ±1.5	68.0 ±2.0	90.0 ±2.5	102.0 ±3.0
Output Overvoltage Type	Crowbar (intentional secondary short circuit to force a reset of charger)						
Temperature Compensation Coefficient (mV/°C)	-30	-60	-80	-90	-120	-180	-180
Equalize Voltage (VDC)	15.5	31.0	41.3	46.5	62.0	82.7	93.0
Equalize Maximum Amps (A)	8	4	3	3	2	1.5	1
Equalize Time	1.5, 2.2 or 3.0 Standard hours						
Recommended Battery Size (Amp-Hours)	200-800	100-400	75-300	60-270	50-200	35-150	30-130
Output Fuses	3x ATM30 Internal	2x ATM25 Internal	2x ATM20 Internal	2x Bel 0697H9200 20A Internal	1x Bel 0697H9150 20A Internal	1x Bel 0697H9200 20A Internal	1x Bel 0697H9200 20A Internal
Output Voltage Adjustment	±1.0 V						
Duty Cycle	Continuous: 100% for 24 hours per day						
Regulation (Line and Load)	+/- 0.1 volts						
Efficiency	> 85% @ Maximum Output						
Charging Stages (Selectable)	2 Stage (CC-Float) or 3 Stage (CC-Absorption-Float), switch selectable						
Number of Battery Banks	1	1 or 2	1 or 2	1 or 2	1 or 2	1 or 2	1 or 2

PWS1050, PWS1050W, PWS1050M, PWS1050MW							
Volts Nominal (VDC)	12	24	32	36	48	72 (rail)	72
Continuous Amps (A)	80	40	30	27	20	15	13
Peak Amps	120	66	50	45	33	24	20
Output Overvoltage Trip (VDC)	17.0 ±0.5	34.0 ±1.0	45.0 ±1.5	51.0 ±1.5	68.0 ±2.0	90.0 ±2.5	102.0 ±3.0
Output Overvoltage Type	Crowbar (intentional secondary short circuit to force a reset of charger)						
Output Fuses (Internal)	3x ATM30	2x ATM25	2x ATM20	2x Bel 0697H9200 20A	2x Bel 0697H9150 20A	1x Bel 0697H9200 20A	1x Bel 0697H9200 20A
Output Voltage Adjustment	±1.0 V						
Duty Cycle	Continuous: 100% for 24 hours per day Peak: 20% for ten minutes per hour maximum						
Transient Response	<1V for 50% Surge						
Regulation (Line and Load)	+/- 0.1 volts						
Efficiency	> 85% @ Maximum Output						
Output Ripple and Noise	< 50 mV						



BCA1550, BCA1550W, BCA1550M, BCA1550MW							
Volts Nominal (VDC)	12	24	32	36	48	72 (rail)	72
Charging Amps (A)	100	60	36		28	20	
Float Voltage (VDC)	13.5	27.2	36.3	40.8	54.4	72.5	81.6
Absorption Voltage (VDC)	14.4	28.8	38.4	43.2	57.6	76.8	86.4
Absorption to Float Switch (Amps)	15	9	6.8		4.5	3	
Output Overvoltage Trip (VDC)	17.0 ±0.5	34.0 ±1.0	45.0 ±1.5	51.0 ±1.5	68.0 ±2.0	90.0 ±2.5	102.0 ±3.0
Output Overvoltage Type	Crowbar (intentional secondary short circuit to force a reset of charger)						
Temperature Compensation Coefficient (mV/°C)	-30	-60	-80	-90	-120	-180	-180
Equalize Voltage (VDC)	15.5	31.0	41.3	46.5	62.0	82.7	93.0
Equalize Maximum Amps (A)	8	4	3	3	2	1.5	1
Equalize Time	1.5, 2.2 or 3.0 Standard hours						
Recommended Battery Size (Amp-Hours)	200-800	100-400	75-300	60-270	50-200	35-150	30-130
Output Fuses	3x ATM30 Internal	2x ATM25 Internal	2x ATM20 Internal	2x Bel 0697H9200 20A Internal	1x Bel 0697H9150 20A Internal	1x Bel 0697H9200 20A Internal	1x Bel 0697H9200 20A Internal
Output Voltage Adjustment	±1.0 V						
Duty Cycle	Continuous: 100% for 24 hours per day						
Regulation (Line and Load)	+/- 0.1 volts						
Efficiency	> 85% @ Maximum Output						
Charging Stages (Selectable)	2 Stage (CC-Float) or 3 Stage (CC-Absorption-Float), switch selectable						
Number of Battery Banks	1	1 or 2	1 or 2	1 or 2	1 or 2	1 or 2	1 or 2

PWS1550, PWS1550W, PWS1550M, PWS1550MW							
Volts Nominal (VDC)	12	24	32	36	48	72 (rail)	72
Continuous Amps (A)	100	55	30	36	28	20	13
Peak Amps	120	66	50	43	33	24	20
Output Overvoltage Trip (VDC)	17.0 ±0.5	34.0 ±1.0	45.0 ±1.5	51.0 ±1.5	68.0 ±2.0	90.0 ±2.5	102.0 ±3.0
Output Overvoltage Type	Crowbar (intentional secondary short circuit to force a reset of charger)						
Output Fuses (Internal)	3x ATM30	2x ATM25	2x ATM20	2x Bel 0697H9200 20A	2x Bel 0697H9150 20A	1x Bel 0697H9200 20A	1x Bel 0697H9200 20A
Output Voltage Adjustment	±1.0 V						
Duty Cycle	Continuous: 100% for 24 hours per day Peak: 20% for ten minutes per hour maximum						
Transient Response	<1V for 50% Surge						
Regulation (Line and Load)	+/- 0.1 volts						
Efficiency	> 85% @ Maximum Output						
Output Ripple and Noise	< 50 mV						



Environmental Specifications

BCA1050, BCA1550, PWS1050, PWS1550

Operating Temperature Range	-25°C to +40°C @ maximum output. Derate Linearly 2.5% per °C from 40°C
Storage Temperature Range	-40°C to +100°C
Humidity	0 - 95% Relative Humidity (non-condensing) with standard conformal coating
Isolation	Input-Case, Input-Output and Output-Case: 1500 VDC
Cooling	Two internal thermostatically controlled fans
Audible Noise	20 dB @ 1 meter when fan operating
Typical Service Life	> 10 years (87,600 hrs)
Warranty	Three years parts and labor
Approvals	Designed to meet UL458 & CSA 22.2.107.1

BCA1050M, BCA1550M, PWS1050M, PWS1550M,

Operating Temperature Range	-40°C to +55°C @ maximum output. Derate Linearly 2.5% per °C from 55°C
Storage Temperature Range	-40°C to +100°C
Humidity	0 - 95% Relative Humidity (non-condensing) with standard conformal coating
Isolation	Input-Case, Input-Output and Output-Case: 1500 VDC
Cooling	Two internal thermostatically controlled fans
Audible Noise	20 dB @ 1 meter when fan operating
Emissions	Designed to meet MIL461F
Shock and Vibration	Designed to meet MIL810G
Typical Service Life	> 10 years (87,600 hrs)
Warranty	Two years parts and labor
Approvals	Designed to meet UL458 & CSA 22.2.107.1

BCA1050W, BCA1550W, PWS1050W, PWS1550W,

Operating Temperature Range	-25°C to +40°C @ maximum output. Derate Linearly 2.5% per °C from 40°C
Storage Temperature Range	-40°C to +100°C
Ingress Protection	IP66 (Dust-proof and protected from high pressure water jets from any direction)
Humidity	0 - 95% Relative Humidity (non-condensing) with standard conformal coating
Isolation	Input-Case, Input-Output and Output-Case: 1500 VDC
Cooling	One internal thermostatically controlled stirring fan
Audible Noise	None, 0 dB
Typical Service Life	> 10 years (87,600 hrs)
Warranty	Three years parts and labor
Approvals	Built to meet CSA 22.2.107.1 & UL458

**BCA1050MW, BCA1550MW, PWS1050MW, PWS1550MW,**

Operating Temperature Range	-40°C to +55°C @ maximum output. Derate Linearly 2.5% per °C from 55°C
Storage Temperature Range	-40°C to +100°C
Humidity	0 - 95% Relative Humidity (non-condensing) with standard conformal coating
Isolation	Input-Case, Input-Output and Output-Case: 1500 VDC
Cooling	Two external thermostatically-controlled fans
Ingress Protection	Sealed to meet IP66 rating. Optional IP67 testing and certification also available.
Audible Noise	40 dB @ 1 meter when fans operating
Emissions	Designed to meet MIL461F
Shock and Vibration	Designed to meet MIL810G
Typical Service Life	> 10 years (87,600 hrs)
Warranty	Two years parts and labor
Approvals	Designed to meet UL458 & CSA 22.2.107.1



Mechanical Specifications

BCA1050, BCA 1550, PWS1050, PWS1550

Length	16.8 in / 42.7 cm
Width	8.2 in / 20.8 cm
Height	3.8 in/ 9.7 cm
Clearance	1.0 in / 2.5 cm all around
Weight	20.0 lb / 9.9 kg (approximately)
Material & Finish	Extruded aluminum chassis and bottom cover, billet machined aluminum end plates, all black anodized
Fasteners	18-8 Stainless steel
Input Connections	3 m / 9.8ft 3xAWG14 power cord with NEMA 5-15 or CEE 7/VII plug
Output Connections	2x Color-coded Phoenix VDFK6 terminal blocks
Battery Temperature Sensor Connection (*)	2x RJ45 'telephone jack' connector

BCA1050M, BCA1550M, PWS1050M, PWS1550M

Length	16.8 in / 42.7 cm
Width	8.2 in / 20.8 cm
Height	3.8 in/ 9.7 cm (5.9 in / 15.0 cm with portable handle and feet)
Clearance	1.0 in / 2.5 cm all around
Weight	20.0 lb / 9.9 kg (approximately)
Material & Finish	Extruded aluminum chassis and bottom cover, billet machined aluminum end plates, all black anodized
Fasteners	18-8 Stainless steel
Input Connections	Amphenol 3-pin Circular MIL-spec GTS02R16-10P connector
Output Connections	Amphenol 4-hole Circular MIL-Spec GTC02R22-22S-RDS connector
Battery Temperature Sensor Connection (*)	Amphenol 4-hole Circular MIL-Spec PT02A-8-4S

BCA1050W, BCA1550W, PWS1050W, PWS1550W

Length	16.8 in / 42.7 cm
Width	8.2 in / 20.8 cm
Height	3.8 in / 9.7 cm (5.9 in / 15.0 cm with portable option)
Clearance	1.0 in / 2.5 cm all around
Weight	20.0 lb / 9.9 kg (approximately)
Material & Finish	Extruded aluminum chassis and bottom cover, billet machined aluminum end plates with O-ring seals, all black anodized
Fasteners	18-8 Stainless steel
Input Connection	1.0 m / 3.0ft 3xAWG14 power cord with NEMA 5-15 or CEE 7/VII compatible plug
Output Connection	4x color-coded flying input leads encased in a watertight Sealcon gland
Battery Temperature Sensor Connection (*)	ConXall 17982-6SG-300 6-Position circular connector receptacle

* Battery Temperature Sensor Connection only available on BCA units.

**BCA1050MW, BCA1550MW, PWS1050MW, PWS1550MW**

Length	16.8 in / 42.7 cm
Width	8.2 in / 20.8 cm
Height	3.8 in/ 9.7 cm
Clearance	1.0 in / 2.5 cm all around
Weight	20.0 lb / 9.9 kg (approximately)
Material & Finish	Extruded aluminum chassis and bottom cover, billet machined aluminum end plates with O-ring seals, all black anodized
Fasteners	18-8 Stainless steel
Input Connections	Amphenol 3-pin Circular MIL-spec GTS02R16-10P connector
Output Connections	Amphenol 4-hole Circular MIL-Spec GTC02R22-22S-RDS connector
Battery Temperature Sensor Connection (*)	Amphenol 4-hole Circular MIL-Spec PT02A-8-4S

* *Battery Temperature Sensor Connection only available on BCA units.*



This page has been intentionally left blank.



This page has been intentionally left blank.



This page has been intentionally left blank.



Limited Warranty

1. The equipment manufactured by Analytic Systems Ware (1993) Ltd. (the "Warrantor") is warranted to be free from defects in workmanship and materials under normal use and service.
2. This warranty is in effect for:
 - a. 3 Years from date of purchase by the end user for standard products offered in our catalog.
 - b. 2 Years from date of manufacture for non-standard or OEM products
 - c. 1 Year from date of manufacture for encapsulated products.
3. Analytic Systems will determine eligibility for warranty from the date of purchase shown on the warranty card when returned within 30 days, or
 - a. The date of shipment by Analytic Systems, or
 - b. The date of manufacture coded in the serial number, or
 - c. From a copy of the original purchase receipt showing the date of purchase by the user.
4. In case any part of the equipment proves to be defective, the Purchaser should do the following:
 - a. Prepare a written statement of the nature of the defect to the best of the Purchaser's knowledge, and include the date of purchase, the place of purchase, and the Purchaser's name, address and telephone number.
 - b. Call Analytic Systems at 800-668-3884 or 604-946-9981 and request a return material authorization number (RMA).
 - c. Return the defective part or unit along with the statement at the Purchaser's expense to the Warrantor; Analytic Systems Ware (1993) Ltd., 8128 River Way, Delta, B.C., V4G 1K5, Canada.
5. If upon the Warrantor's examination the defect proves to be the result of defective material or workmanship, the equipment will be repaired or replaced at the Warrantor's option without charge, and returned to the Purchaser at the Warrantor's expense by the most economical means. Requests for a different method of return or special handling will incur additional charges and are the responsibility of the Purchaser.
6. Analytic Systems reserves the right to void the warranty if:
 - a. Labels, identification marks or serial numbers are removed or altered in any way.
 - b. Our invoice is unpaid.
 - c. The defect is the result of misuse, neglect, improper installation, environmental conditions, non-authorized repair, alteration or accident.
7. No refund of the purchase price will be granted to the Purchaser, unless the Warrantor is unable to remedy the defect after having a reasonable number of opportunities to do so.
8. Only the Warrantor shall perform warranty service. Any attempt to remedy the defect by anyone else shall render this warranty void.
9. There shall be no warranty for defects or damages caused by faulty installation or hook-up, abuse or misuse of the equipment including exposure to excessive heat, salt or fresh water spray, or water immersion except for equipment specifically stated to be waterproof.
10. No other express warranty is hereby given and there are no warranties that extend beyond those described herein. This warranty is expressly in lieu of any other expressed or implied warranties, including any implied warranty of merchantability, fitness for the ordinary purposes for which such goods are used, or fitness for a particular purpose, or any other obligations on the part of the Warrantor or its employees and representatives.
11. There shall be no responsibility or liability whatsoever on the part of the Warrantor or its employees and representatives for injury to any person or persons, or damage to property, or loss of income or profit, or any other consequential or resulting damage which may be claimed to have been incurred through the use or sale of the equipment, including any possible failure of malfunction of the equipment, or part thereof.
12. The Warrantor assumes no liability for incidental or consequential damages of any kind



DESIGNED AND MANUFACTURED BY



ANALYTIC SYSTEMS
Power Conversion Solutions

Battery Chargers • Inverters • Power Supplies • Voltage Converters



800-668-3884



604-946-9983



Support@analyticsystems.com



www.analyticsystems.com



101-8128 River Way
Delta, B.C. V4G 1K5 | Canada

Register Products Online | www.analyticsystems.com/support/warranty-registration