

DESCRIPTION:
SNAPNRACK, ULTRA RAIL S TILE REPLACEMENT KIT

PART NUMBER(S):
242-01227

DRAWN BY:
 mwatkins

REVISION:
A

SnapNrack™
 Solar Mounting Solutions

595 MARKET STREET, 29TH FLOOR • SAN FRANCISCO, CA 94105 USA
 PHONE (415) 580-6900 • FAX (415) 580-6902

THE INFORMATION IN THIS DRAWING IS CONFIDENTIAL AND PROPRIETARY. ANY REPRODUCTION, DISCLOSURE, OR USE THEREOF IS PROHIBITED WITHOUT THE WRITTEN CONSENT OF SUNRUN SOUTH LLC.

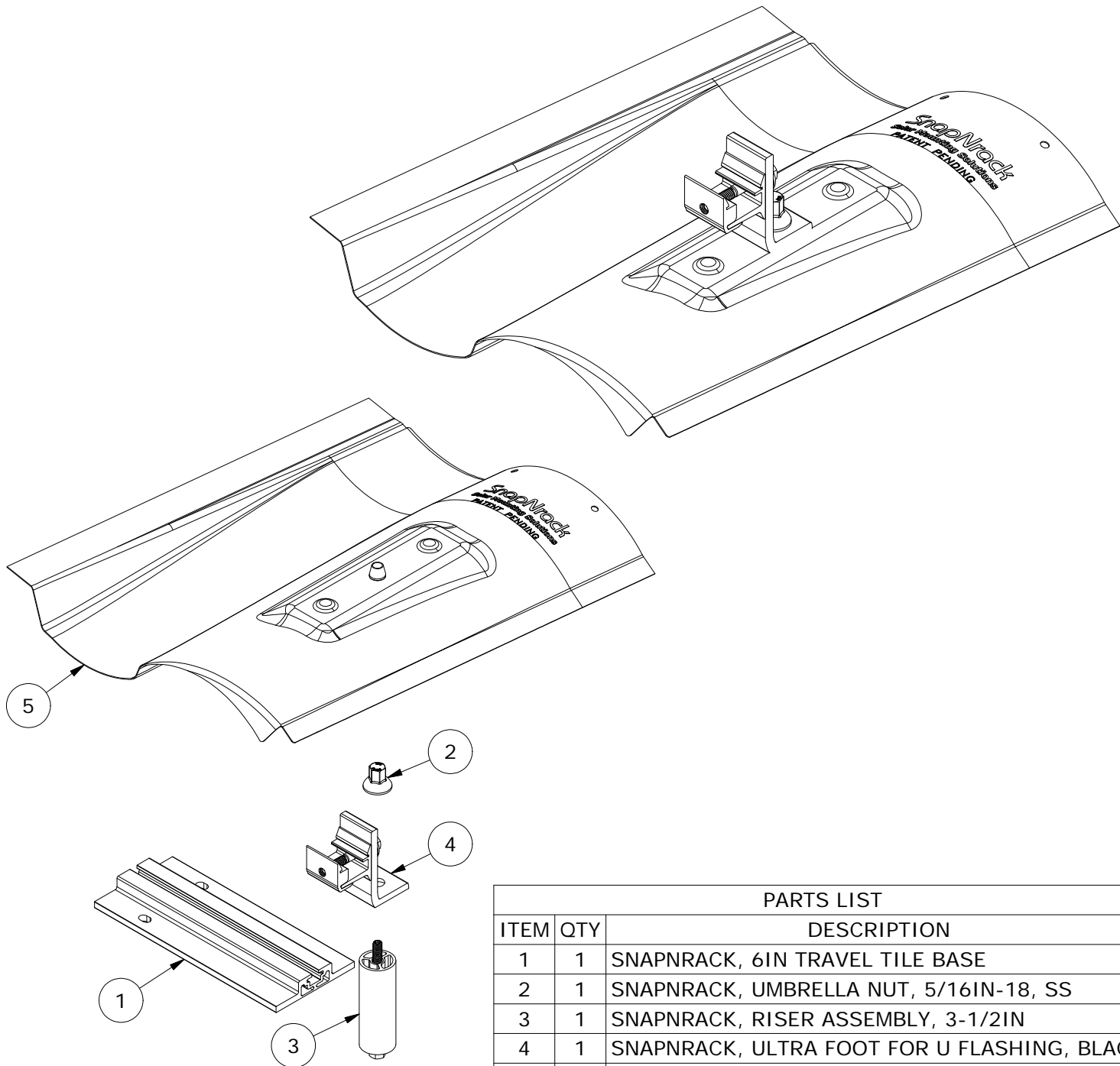

PARTS LIST		
ITEM	QTY	DESCRIPTION
1	1	SNAPNRACK, 6IN TRAVEL TILE BASE
2	1	SNAPNRACK, UMBRELLA NUT, 5/16IN-18, SS
3	1	SNAPNRACK, RISER ASSEMBLY, 3-1/2IN
4	1	SNAPNRACK, ULTRA FOOT FOR U FLASHING, BLACK
5	1	SNAPNRACK, S TILE REPLACEMENT

MATERIALS:	6000 SERIES ALUMINUM, DEAD SOFT ALUMINUM, STAINLESS STEEL
DESIGN LOAD (LBS):	445 UP, 1333 DOWN, 93 SIDE
ULTIMATE LOAD (LBS):	1256 UP, 4000 DOWN, 279 SIDE
TORQUE SPECIFICATION:	10 (UMBRELLA NUT), 12 (MOUNT) LB-FT
CERTIFICATION:	UL 2703, FILE E359313
WEIGHT (LBS):	2.60

DESCRIPTION:
**SNAPNRACK, ULTRA RAIL S TILE REPLACEMENT
 KIT**

DRAWN BY:

mwatkins

REVISION:

A

SnapNrack™
 Solar Mounting Solutions

PART NUMBER(S):

242-01227

595 MARKET STREET, 29TH FLOOR • SAN FRANCISCO, CA 94105 USA
 PHONE (415) 580-6900 • FAX (415) 580-6902

THE INFORMATION IN THIS DRAWING IS CONFIDENTIAL AND PROPRIETARY. ANY
 REPRODUCTION, DISCLOSURE, OR USE THEREOF IS PROHIBITED WITHOUT THE
 WRITTEN CONSENT OF SUNRUN SOUTH LLC.

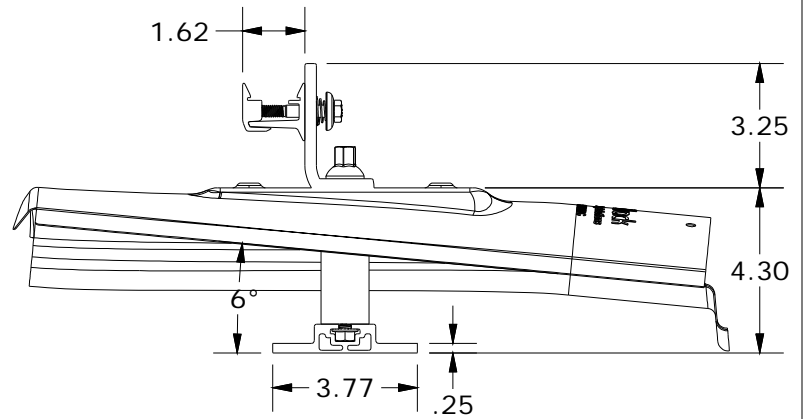
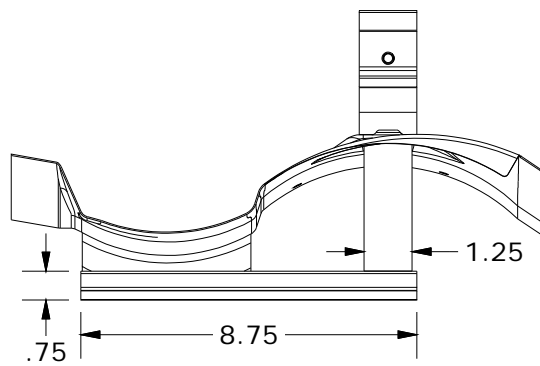
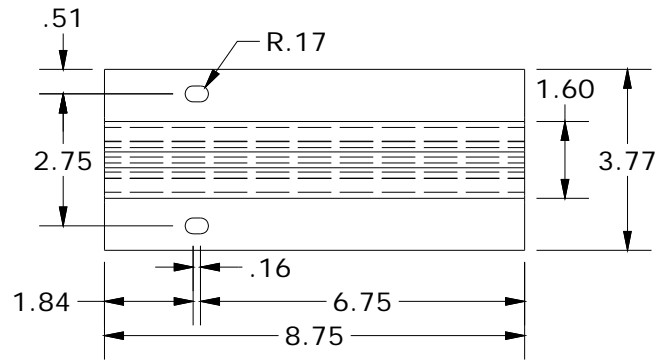
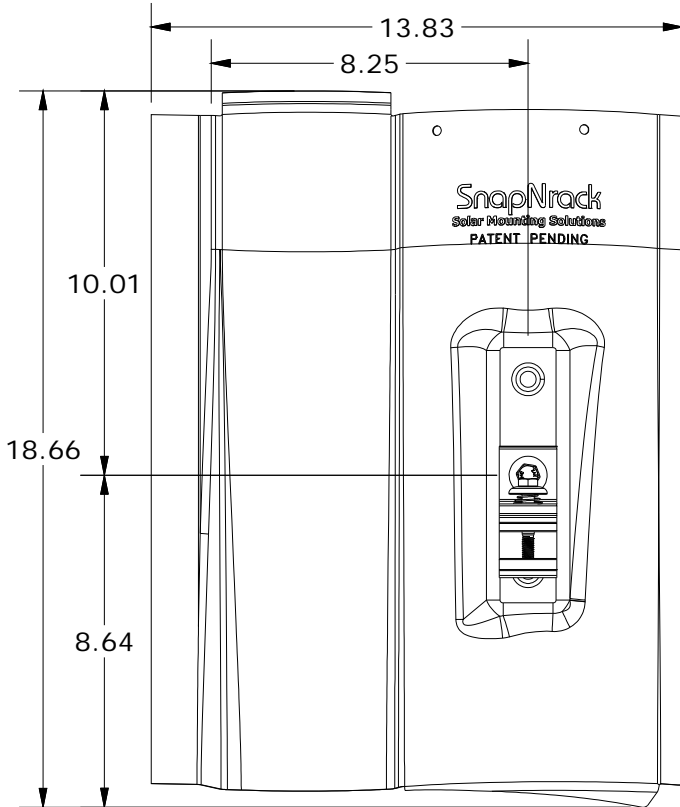

ALL DIMENSIONS IN INCHES