

# CONNECTING STRENGTH

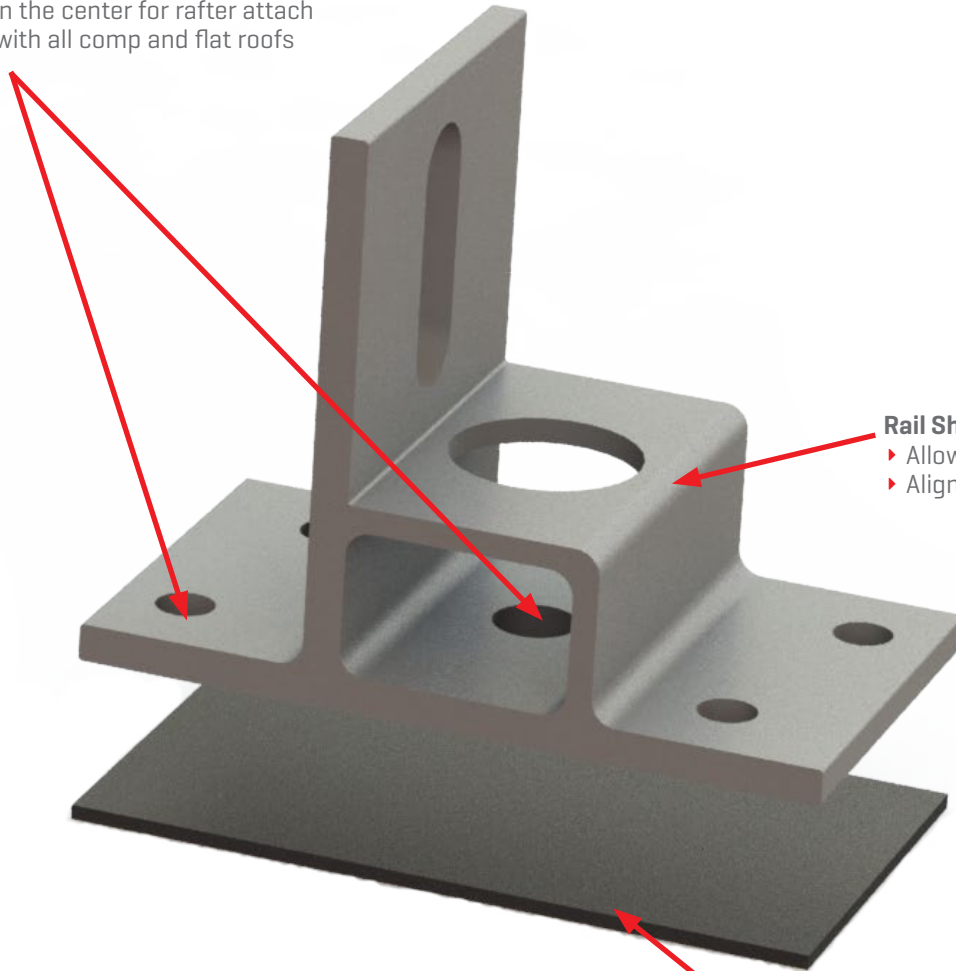

## Rafter or Deck Attach

- ▶ 4 screws in the corners for deck attach
- ▶ 1 lag screw in the center for rafter attach
- ▶ Compatible with all comp and flat roofs



## Rail Shelf

- ▶ Allows for easier rail support
- ▶ Aligns CrossRail T-Bolt channel

## K2 EverSeal

- ▶ Pre-installed rubber flexible flashing
- ▶ 30+ years of proven water sealing technology
- ▶ TAS 100[A] and Wind Driven Rain tested and approved



# K2 Flex Foot

## PRODUCT SHEET

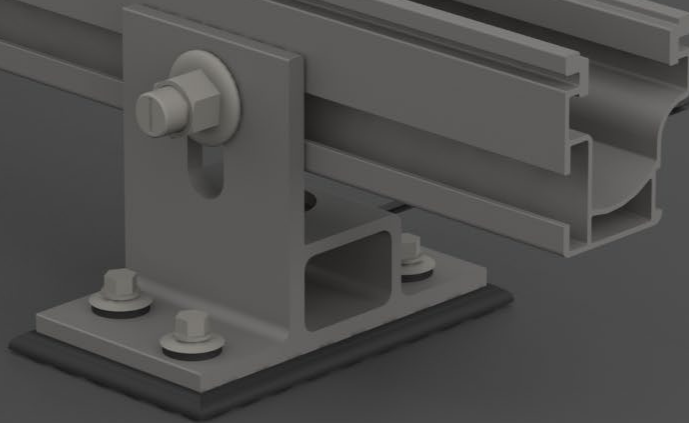
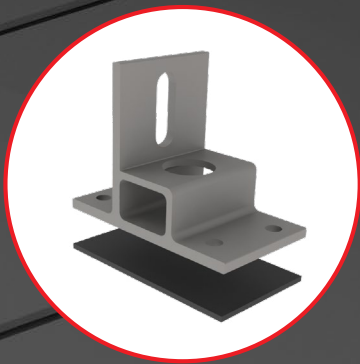

# K2 Flex Foot

## PRODUCT SHEET

Part Number	Description
4000718	K2 Flex Foot Kit, Mill w/EverSeal

- ▶ Rafter [1 screw] or deck [4 screws] attach options
- ▶ Compatible with comp shingle and flat roofs
- ▶ Preassembled with K2 EverSeal
- ▶ 30+ years of proven water sealing technology
- ▶ TAS 100(A) and Wind Driven Rain tested and approved
- ▶ Compatible with concrete anchors
- ▶ 360 degree rotation with lag