

K2 Flex Foot

INSTALLATION MANUAL

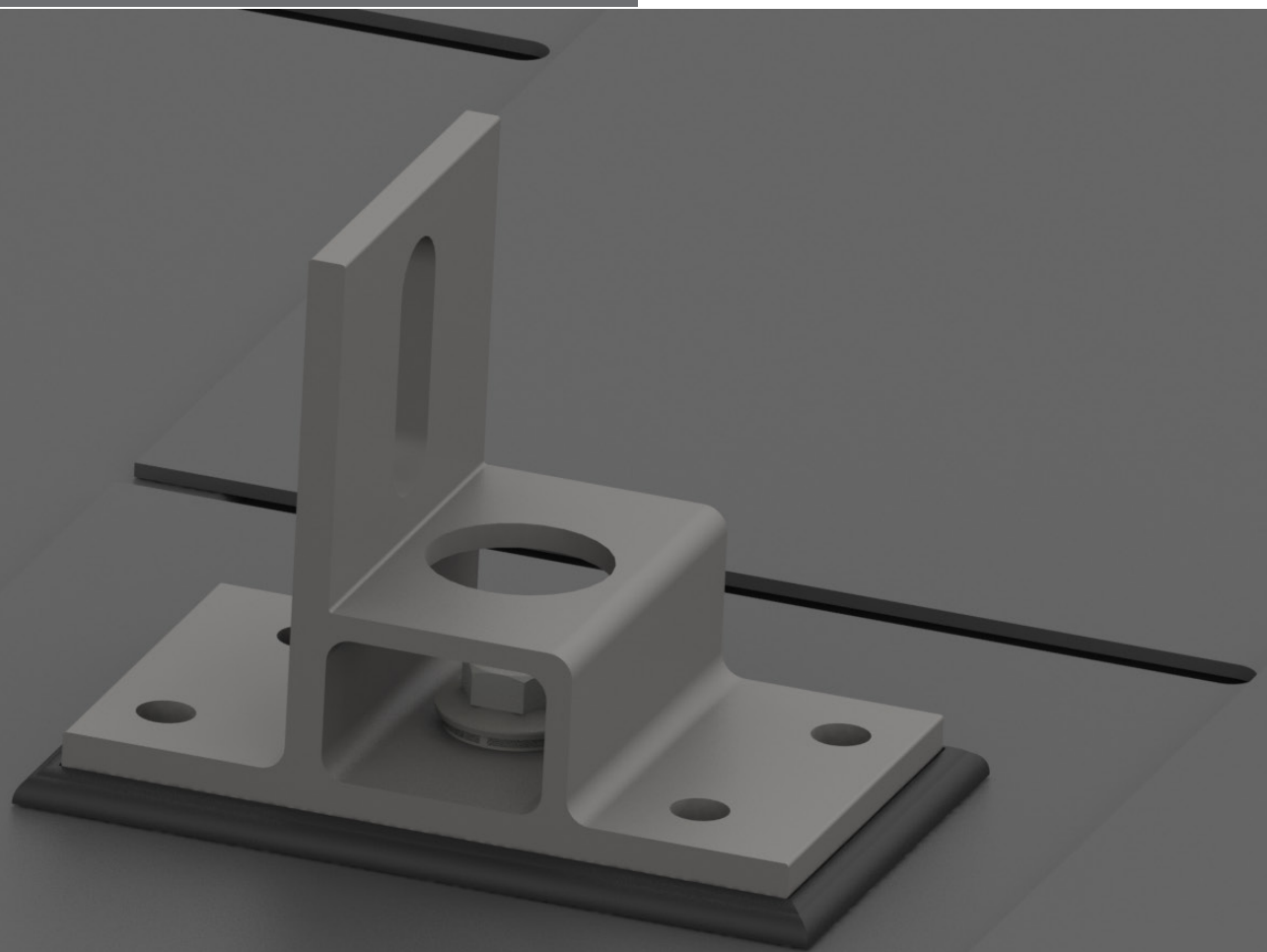

Content

▶ General Safety Information	3
· Roof requirements	4
· Structural requirements	4
· Important mounting instructions	4
▶ Tools Overview	5
▶ Components	6
▶ Assembly	8
▶ K2 Flex Foot Dimensions	13
▶ Bonding and Grounding	14
▶ Fire Rating	15
▶ Compatible Modules	16
▶ Notes	20

Quality tested – several certifications

K2 Systems stands for secure connections, highest quality and precision. Our customers and business partners have known that for a long time. Independent institutes have tested, confirmed and certified our capabilities and components.

Please find our quality and product certificates under:
k2-systems.com/en-US/company/quality-management-and-certificates

General Safety Information



Please note that our general mounting instructions must be followed at all times and can be viewed online at <https://k2-systems.com/en-US/downloads/documentation>

- ▶ The equipment may only be installed and operated by qualified and adequately trained installers.
- ▶ Prior to installation, ensure that the product complies with on-site static loading requirements. For roof-mounted systems, the roof load-bearing capacity must always be checked.
- ▶ National and local building regulations and environmental requirements must be adhered to.
- ▶ Compliance with health and safety regulations, accident prevention guidelines and applicable standards are required.
 - Protective equipment such as safety helmet, boots and gloves must be worn.
 - Roofing works must be in accordance with roofing regulations utilizing fall protection safeguards when eaves height exceeds 3 m.
 - At least two people must be present for the duration of the installation work in order to provide rapid assistance in the event of an emergency.
- ▶ K2 mounting systems are continuously developed and improved and the installation process may thereby change at any time. Prior to installation consult our website at: <https://k2-systems.com/en-US/downloads/documentation> for up-to-date instructions. We can send you the latest version on request.
- ▶ The assembly instructions of the module manufacturer must be adhered to.
- ▶ Equipotential bonding/grounding/earthing between individual parts is to be performed according to country specific standards, as well as national laws and regulations.
- ▶ At least one copy of the assembly instructions should be available on site throughout the duration of the installation.
- ▶ Failure to adhere to our general safety and assembly instructions and not using all system components, K2 is not liable for any resulting defects or damages. We do not accept liability for any damage resulting in the use of competitor's parts. Warranty is excluded in such cases.
- ▶ If all safety instructions are adhered to and the system is correctly installed, there is a product warranty entitlement of 25 years! We strongly recommend reviewing our terms of guarantee, which can be viewed at <https://k2-systems.com/en-US/downloads/documentation>. We will also send this information on request.
- ▶ Dismantling of the system is performed in reverse order to the assembly.
- ▶ K2 stainless steel components are available in different corrosion resistance classes. Each structure or component must be carefully checked for possible corrosion exposure.
- ▶ The installer is solely responsible for:
 - ▶ Handling and installing the PV modules and rail system according to the manufacturer's instruction, with special attention for the suggested clamping locations on the frame. attention for the suggested clamping locations on the frame.
 - ▶ Complying with all applicable local or national building codes, standards and industry best practices including any code that may supersede this manual.
 - ▶ Ensuring that K2's and other products are appropriate for the specific installation and the installation location.
 - ▶ Using only K2 parts and installer-supplied parts as specified by K2. [Substitution of parts may void the warranty and invalidate the letters of certification.]
 - ▶ Verifying the strength of any alternate mounting devices used in lieu of the anchoring screws.
 - ▶ Ensuring safe installation of all electrical and mechanical aspects of the PV array.
 - ▶ Ensuring correct and appropriate design parameters are used in determining the design loading used for design of the specific installation. Parameters, such as snow loading, wind speed, exposure and topographic factor should be confirmed with the local building official or a licensed professional engineer.
 - ▶ K2 recommends inspecting installed racking system periodically for loose components, loose fasteners and any corrosion.

The following guidelines apply

The CrossRail System can be installed as standard under the following conditions. Even if the system is capable of meeting higher demands through the integration of safety standards, please get in touch with your contact at K2 Systems if the specified values are exceeded.



Roof Requirements

- ▶ The sufficient holding force of the roof covering at the support or substructure must be ensured on site.
- ▶ Roof pitch: 5 - 75°
- ▶ For low slope roofs, make sure there is positive drainage and roofing is compatible with butyl.



Structural Requirements

The static verification of the component is automatically calculated with the K2 Base planning software for the respective location. The design provided in a project report must be followed.

Ensuring that the roof, its rafters, connections, and other structural support members can support the array under all code level loading conditions.



Important Mounting Instructions

- ! Maintaining the waterproof integrity of the roof. To maintain the flashing performance, avoid installation when the temperature of the roof and butyl are below 22F or above 176F. K2 EverSeal must be installed on a dry surface.
- ▶ K2 Systems recommends a thermal splice every 14 Ft., however, it must be determined by the installer based on the rail system installation instructions. The installer must also determine the maximum allowed span and cantilever design parameters recommended by the rail system manufacturer. The K2 Flex Foot can be installed on steep slope roofs (composite shingles). The K2 EverSeal is also compatible with felt and synthetic underlayments.

Moisture Content

- ▶ The K2 EverSeal is to be installed on dry mounting surfaces.
- ▶ Determining how wet is too wet: First, remove the paper backing from the K2 Flex Foot exposing the clean butyl. Second, press the base, K2 EverSeal side down against the surface. Third, pick up the base. If the base adheres to the roof, the roof is suitably dry for installation.
- ▶ A heat gun, roof dryer, calcium chloride or alcohol is suitable to remove ice from the roof surface.

Periodical Inspection

- ▶ K2 recommends inspecting installed racking system periodically for loose components, loose fasteners and any corrosion. If found, those components are to be retightened, or replaced immediately.
- ▶ When a PV module needs to be removed from the PV array for maintenance and/or replacement, the electric bonding system may need to be temporarily restored to maintain the electrical bonding path. Please make sure the system electrical circuits and disconnects are in the open position and the entire system is powered down. Cover the fronts of modules in the array with an opaque material to stop the production of electricity. Use appropriate safety equipment such as insulated tools and insulating gloves to protect yourself.

Tools Overview



Chalk Line
≥ 3.0 m

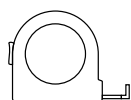

Tape Measure
≥ 6.0 m

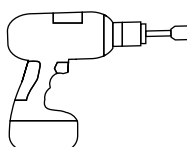

Drill

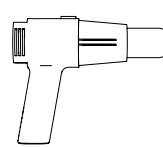

Heat Gun



Torque Wrench
6 - 35 Nm
(4.5 - 22.2 lb-ft)



13mm Socket



1/4" Nut Driver

Torque Overview

- ▶ M10 T-Bolts: 25.8 ft-lb [35 Nm]

Technical Note

- ▶ Proper torque values for a wood screw will vary depending on the rafter and/or deck characteristics; hardness, age, and moisture of the wood. Tighten the splice foot screws until the conical washer stops rotating.
- ▶ Stainless hardware is soft and if dry torqued too quickly it may cause the nut and bolt to seize.
- ▶ K2 Systems recommends all stainless steel threads be lubricated. This will make it easier to tighten nuts to bolts, avoid galling, and facilitate adjustments before the nut is properly torqued. Therefore, avoid the use of an impact driver.

Tools and materials for the installation of third party items such as roof attachment products, roof covering and sealing products or items used for bonding and grounding are not listed here. Please refer to the instructions of those third party products.

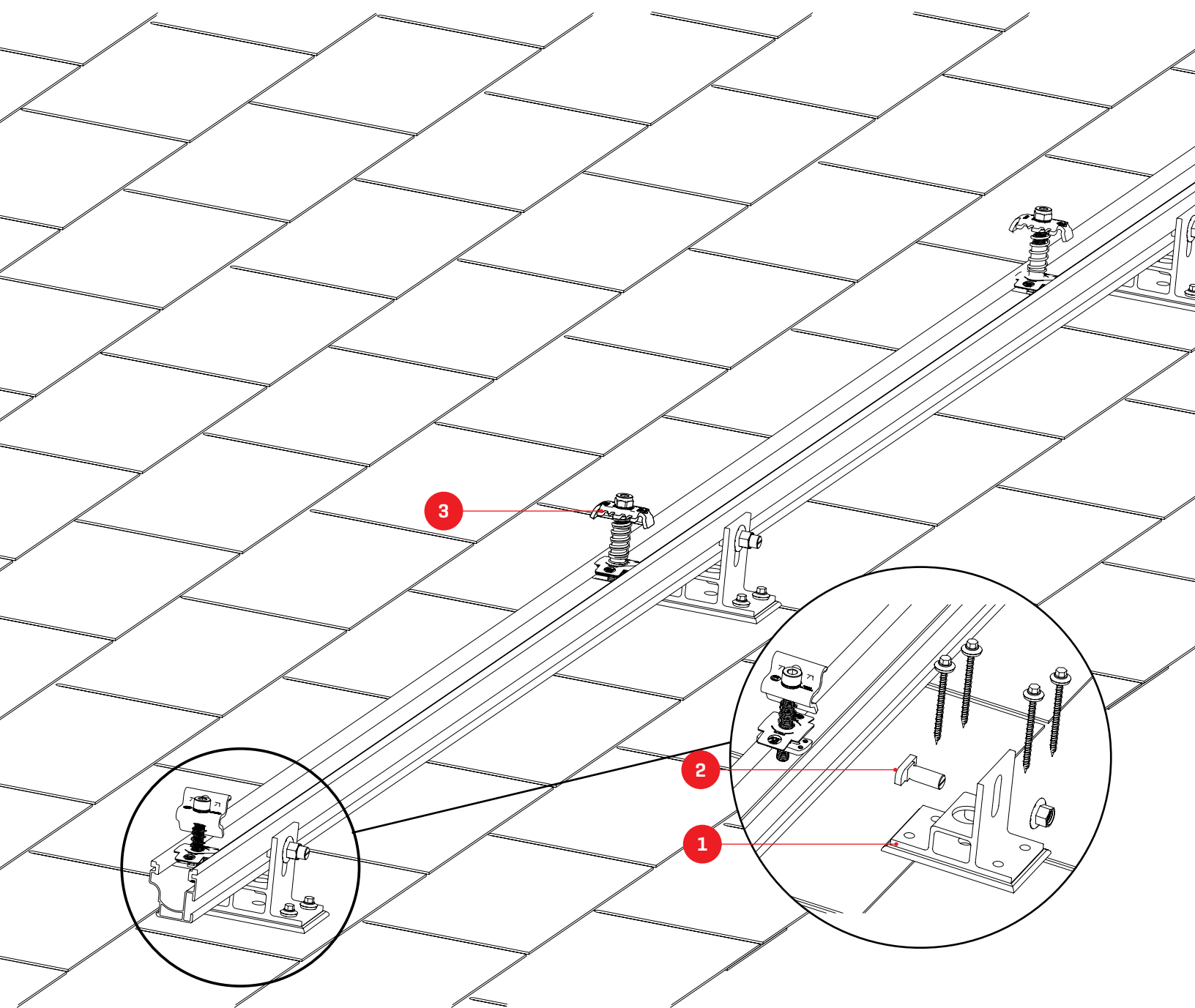

1 4000718

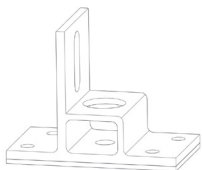

K2 Flex Foot

2

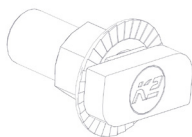

T-Bolt & Hex

3 4000601-H, 4000602-H

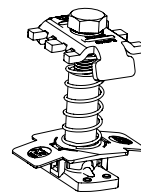

Mid Clamp
30 - 50 mm module frame height

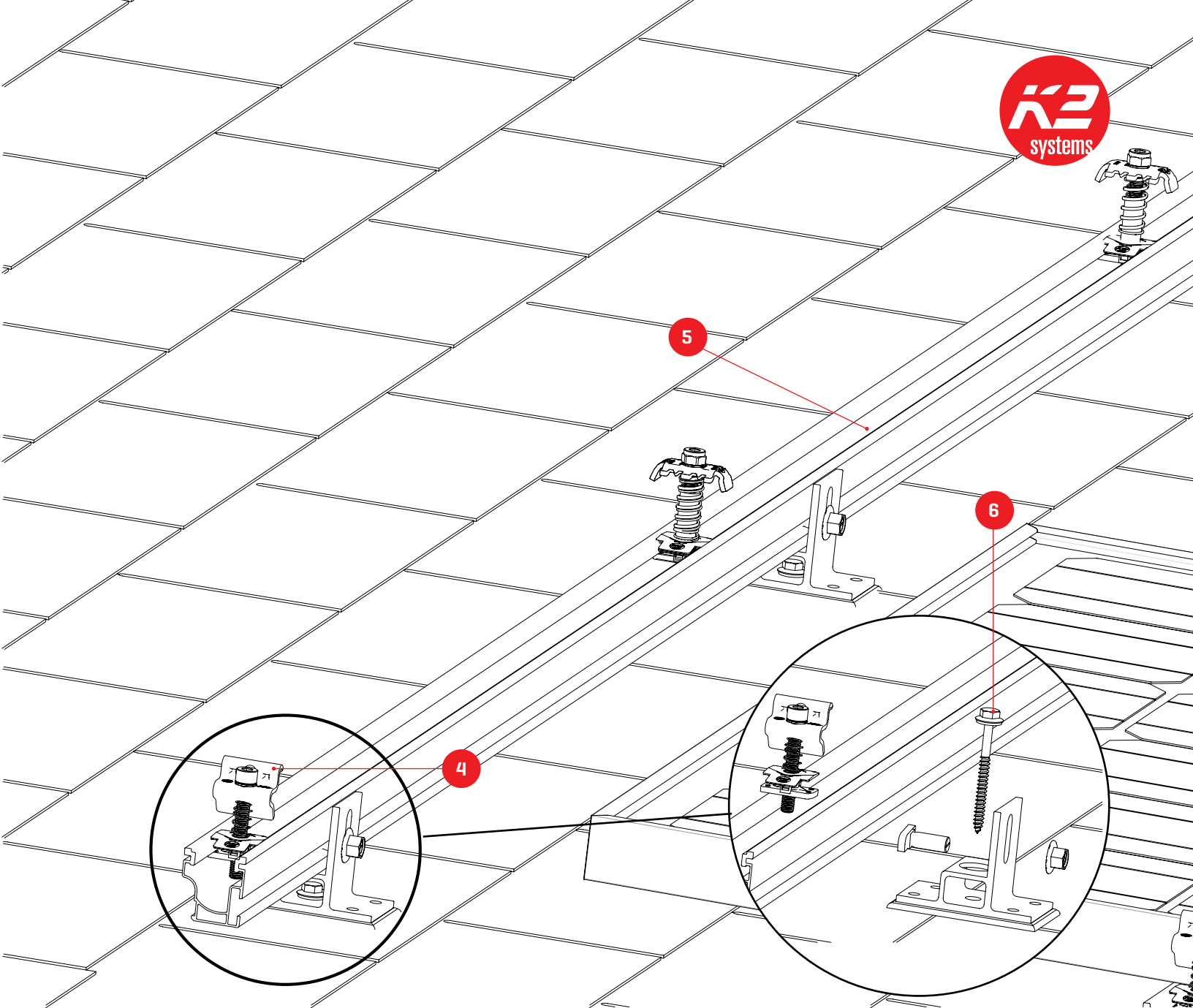

4 4000090 / 4000050-H

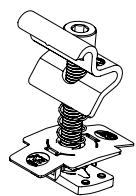

End Clamp or Yeti Clamp
30 - 50 mm module frame height

5 4000019, 4000020

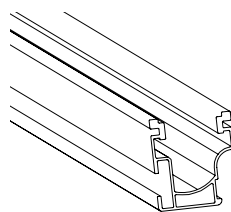

CrossRail
44-X shown & PNs listed
Works with all CR profiles

6 4000115 - Wood Screw
4000170 - Lag Screw

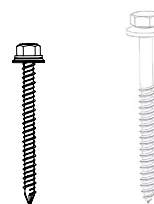

Assembly

Part A: Marking the array and mounting locations

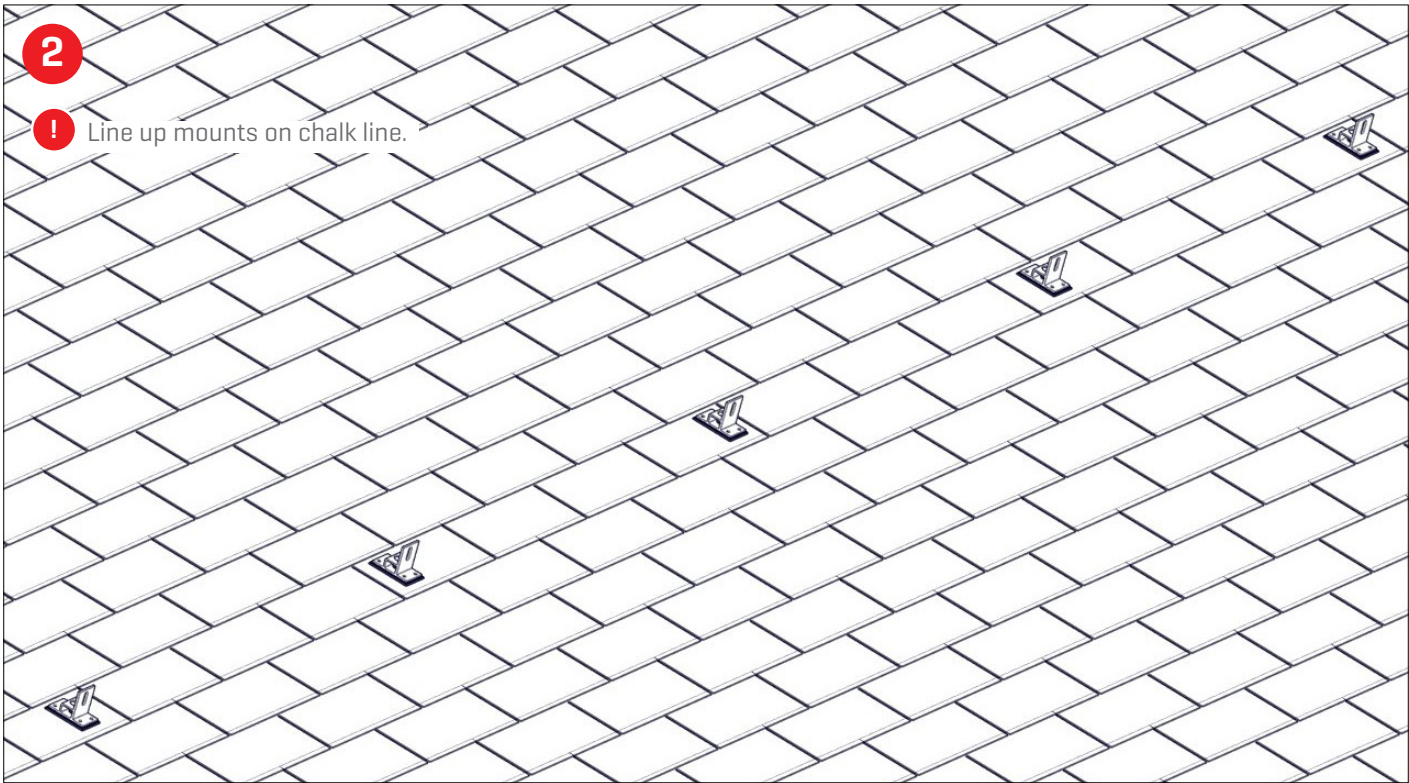
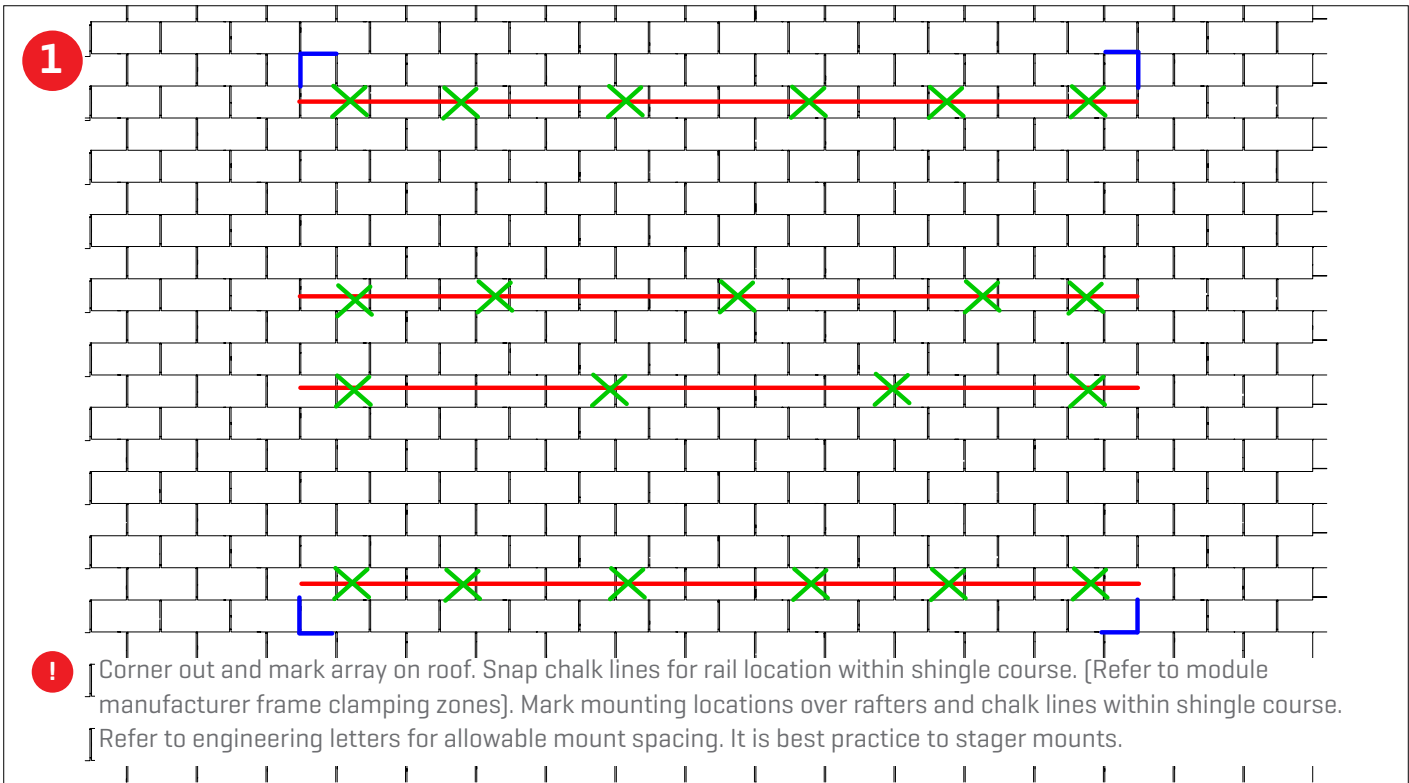

Part B: Mount Placement and Installation for Rafter Connection

! To maintain flashing performance, avoid installation when the temperature of the roof and/or butyl is below 22F or above 176F. K2 EverSeal must be installed on a dry surface.

1

!

Locate the rafter and clean roofing surface for mount placement. Drill your pilot hole into the rafter using a 9/64" drill bit. Peel back protective paper from butyl, and stick down mount on a single shingle course with the center hole lining up over the rafter. Position all mounts in the same direction with the rail shelf towards the ridge. Drive chosen lag screws into the rafter until the conical washer is flat and not concaved, providing a positive seal. Do not over torque.

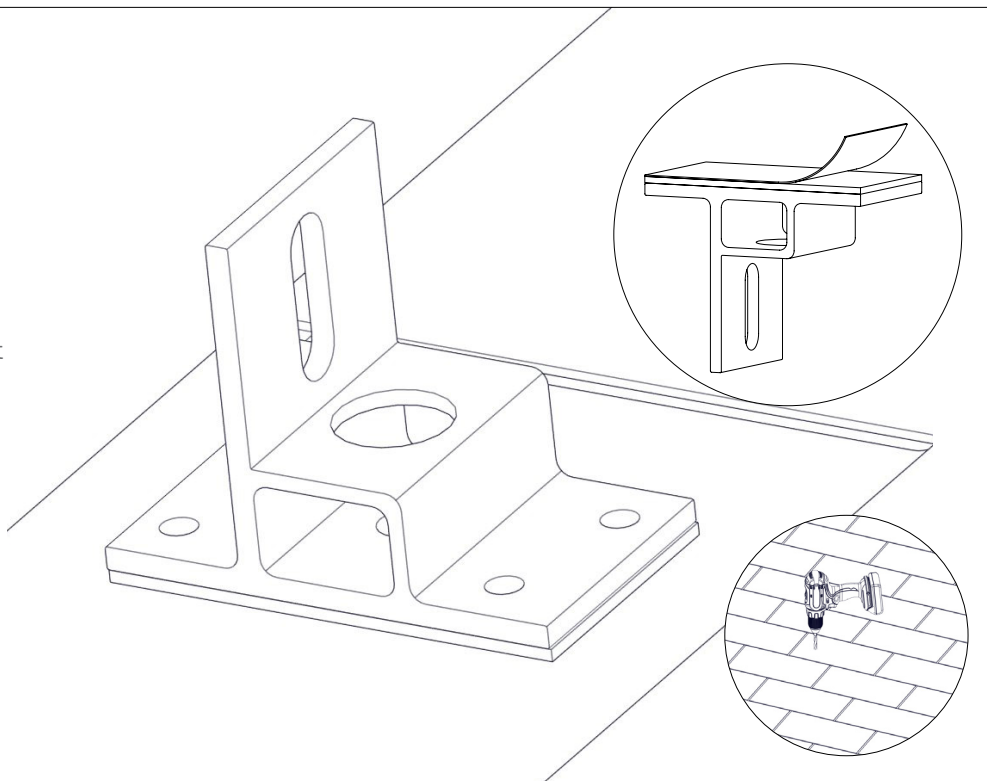

2

! The distance from the edge of the rafter and the wood screws must be at least 5/16" from the edge.
 NOTE: Minimum Edge Distance = 1.5D Where D is the diameter of the screw.
 NOTE: The screw shall hit the area that is marked by the red box.

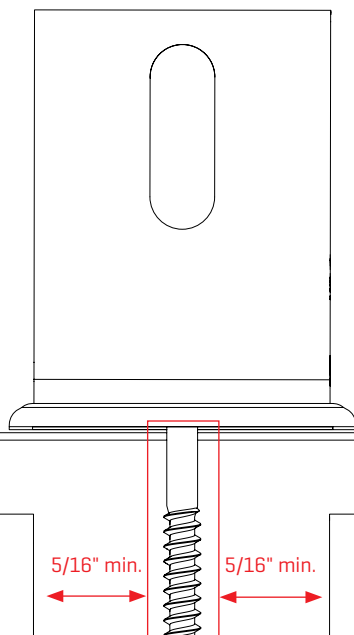

Part C: Mount Placement and Installation for Deck Connection



To maintain flashing performance, avoid installation when the temperature of the roof and/or butyl is below 22F or above 176F. K2 EverSeal must be installed on a dry surface.

1



For deck attachments, follow steps in B2, but only use Splice Foot screws in the four corners of the mount. When possible always attach mounts to the rafter and only use deck attached as a secondary option when rafters are not within mounting zones for the array. Follow K2 engineered calculations and span charts for deck attachments. Ensure that the mount faces toward the ridge of the roof. When deck attaching check for positive engagement into plywood and avoid plywood seams. It should be tightened until the conical washer stops rotating.

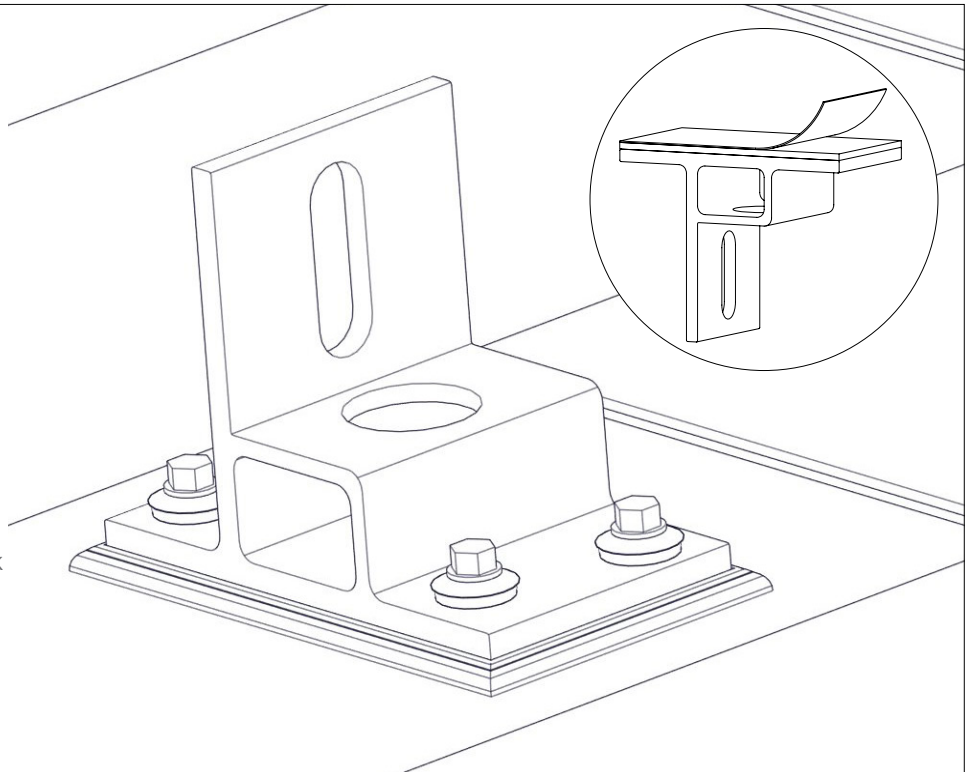

Part D: Ensuring Proper Installation

1



Proper torque will vary based on the characteristics of the rafter and deck. It's best practice to tighten the wood screws until the washer stops rotating. After completing process, make sure the K2 Flex Foot is securely fixed. You may verify that the screws underneath the deck panel are stained with butyl rubber. This indicates a good flashing performance. Butyl should extrude from the sides of the mount.

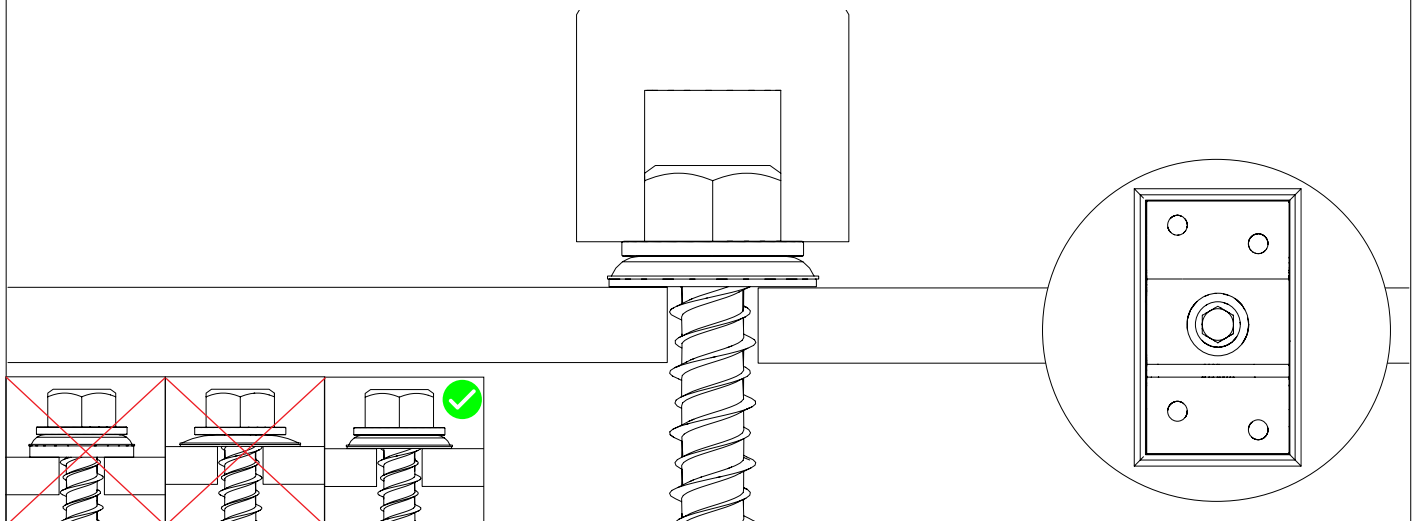

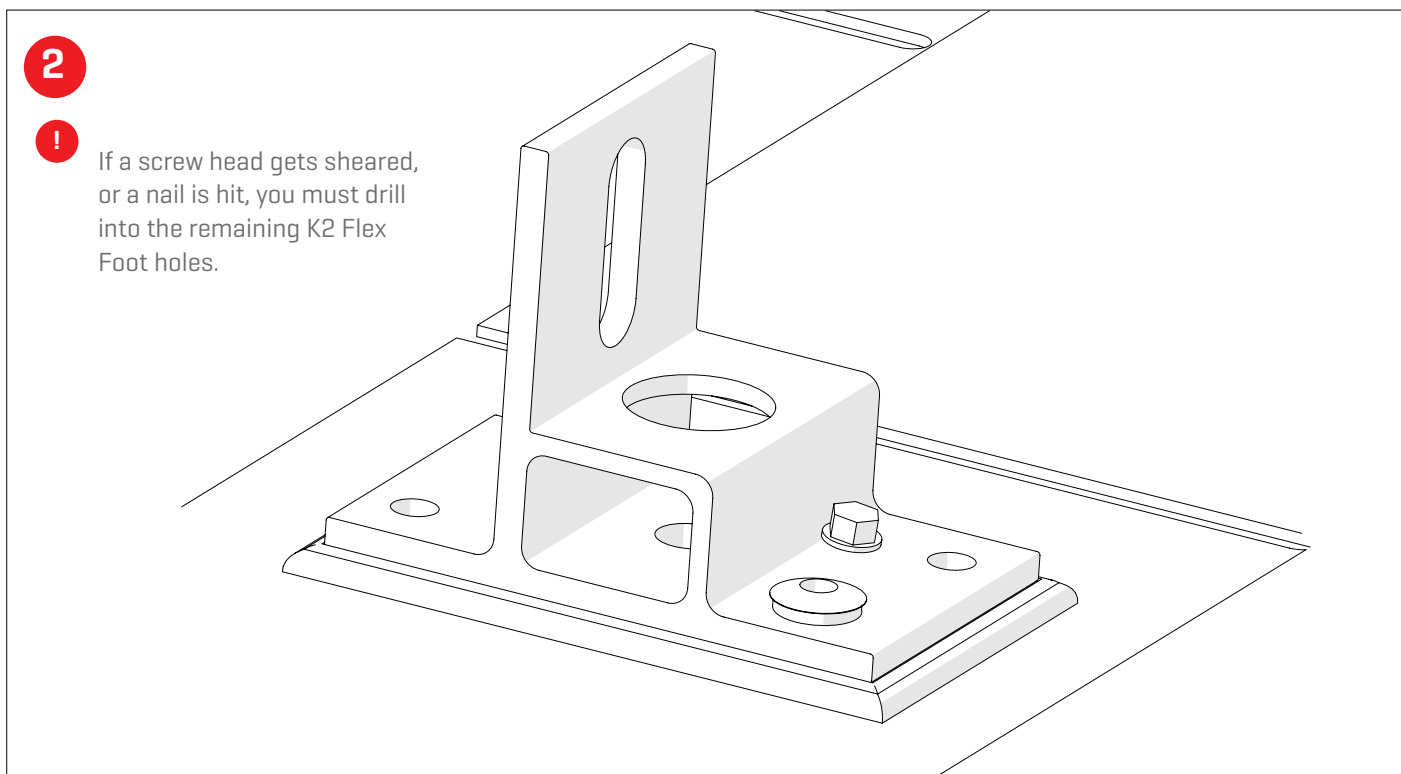

Part E: Leveling Uneven Roof Surfaces

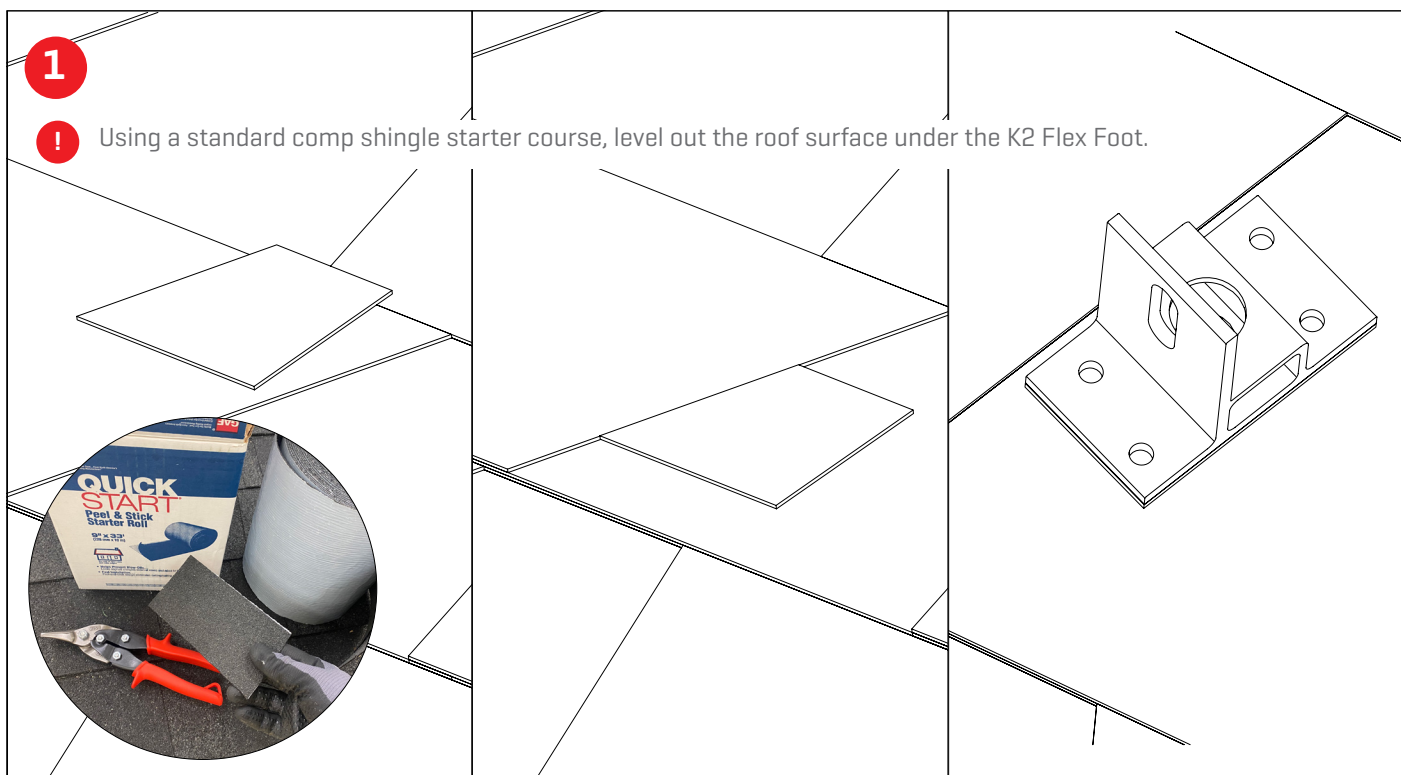

Part F: Attaching CrossRail

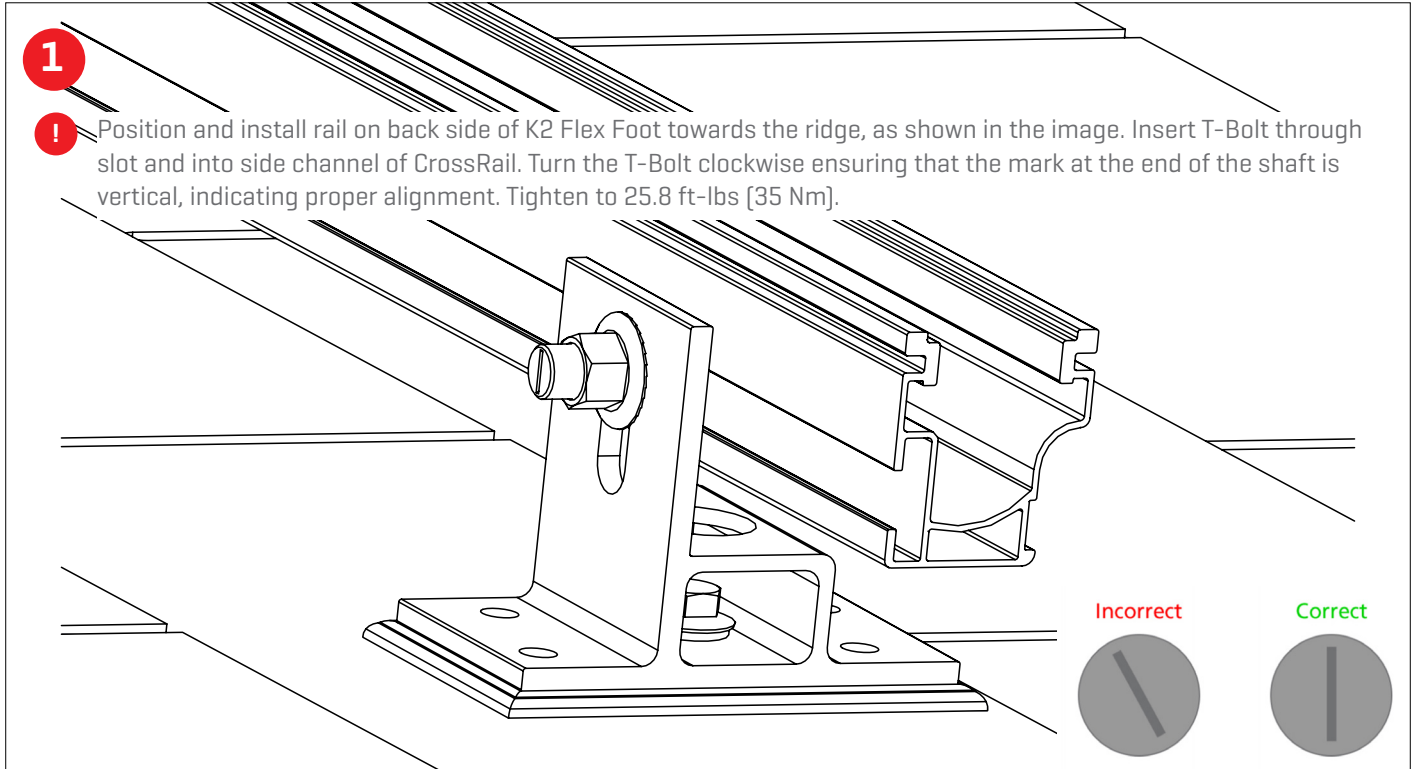

K2 Flex Foot

Units: [in] mm

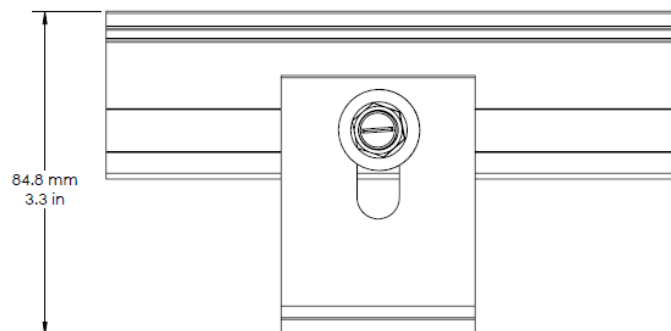
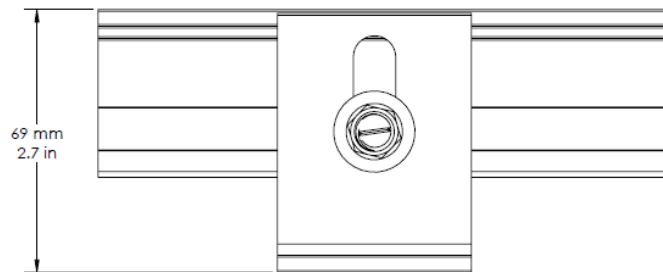
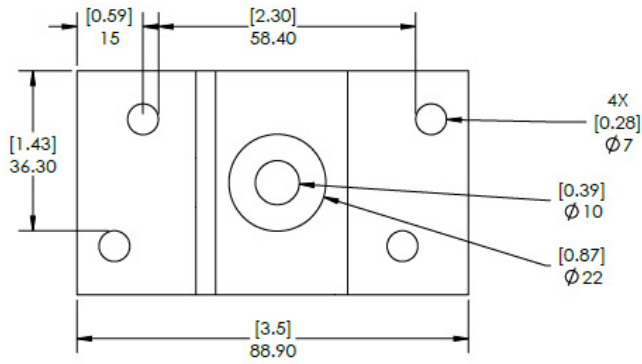
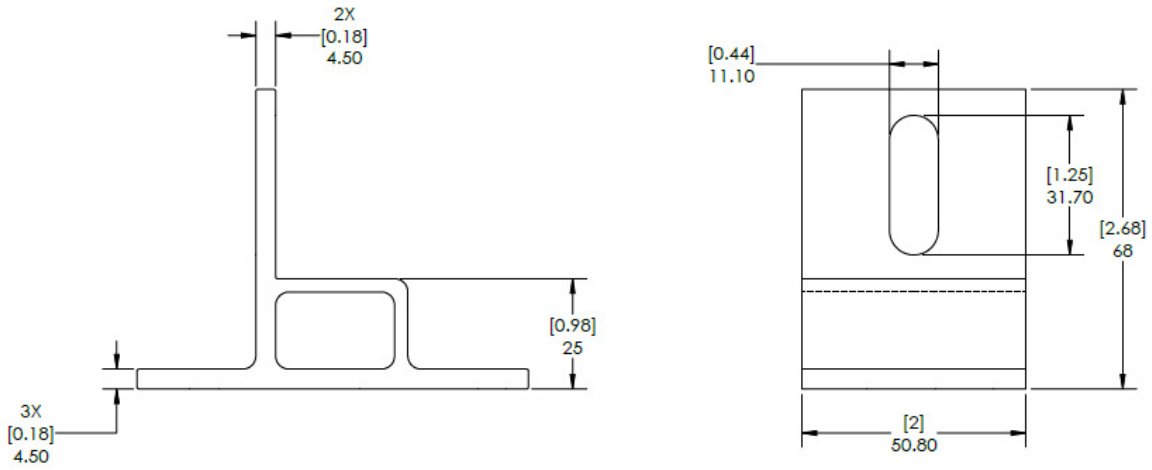

Bonding and Grounding

Appropriate means of bonding and grounding are required by regulation. The information provided in this manual shall always be verified with local and national building codes.

K2 Systems has obtained a UL 2703 system listing from Underwriter's Laboratories [UL].

A sample bonding path diagram is shown in Figure 1 below. Your specific installation may vary, based upon site conditions and your AHJ's requirements.

Each electrical connection has been evaluated to a maximum fuse rating of 30A. At least one ground lug per row of modules must be used to ground all strings within each sub-array, although additional may be used for redundancy. When installed per these installation instructions, all connections meet the requirements of NEC 690.43.

This racking system may be used to ground and/or mount a PV module complying with UL 1703 only when the specific module has been evaluated for grounding and/or mounting in compliance with the included instructions.

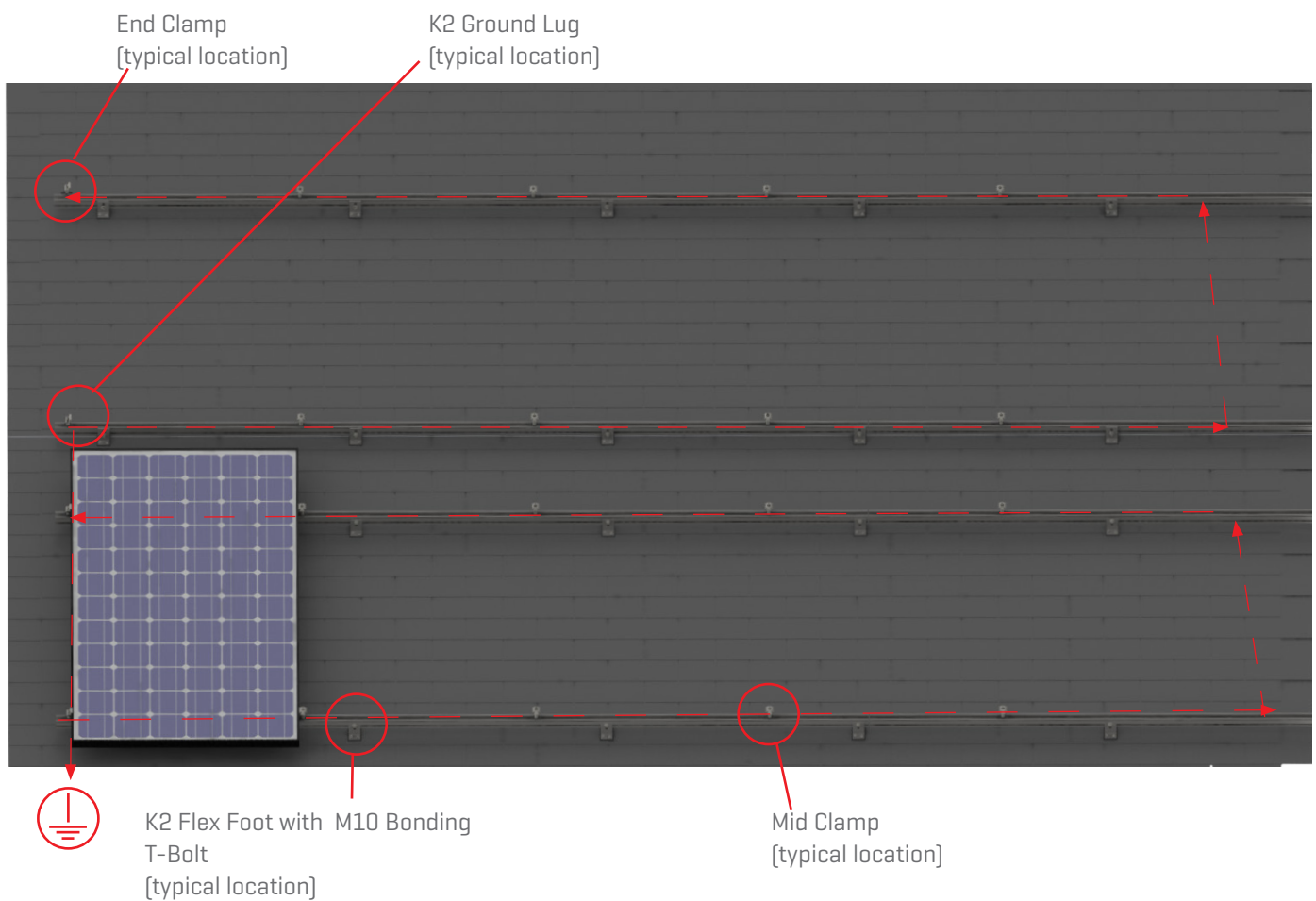



Fire Rating

The CrossRail System has undergone fire performance testing in accordance with UL 2703, Fire Performance. A System Class A fire rating is achieved when using CrossRail 44-X/48-X/48-XL under the following conditions:

- ▶ Roof slope of 2/12" rise per linear foot or greater
- ▶ Used in combination with a UL 1703 Listed module with a fire performance rating of Type 1, Type 2, or Type 3. Consult the module manufacturer for specific fire performance rating information.
- ▶ CrossRail may be mounted using any stand-off height to maintain the Class A fire rating. Always consult the module manufacturer's installation instructions to ensure your installation is in compliance with their UL 1703 Listing.
- ▶ The results of the racking system do not improve a roof covering Class rating.

All documentation can be found on UL's Online Database as well as K2 Systems' website.

Compatible Modules

K2's CrossRail System was tested with the following:

- ▶ UL/NRTL Listed Aptos Solar Modules:
 - DNA-120-MF26-XXXW
 - DNA-144-MF26-XXXW
 - DNA-120-BF23-XXXW
 - DNA-120-MF23-XXXW
 - DNA-144-BF23-XXXW
 - DNA-144-MF23-XXXW
- ▶ UL/NRTL Listed Axitec Modules:
 - AC-xxP/156-60S
 - AC-xxxM/156-60S
 - AC-xxxP/60V
 - AC-xxxP/60xV
 - AC-xxxP/60S
 - AC-xxxP/60x
 - AC-xxxMH/120S
 - AC-xxxM/60V
 - AC-xxxM/60xV
 - AC-xxxMH/120V
 - AC-xxxM/60S
 - AC-xxxM/60x
 - AC-xxxP/156-72S
 - AC-XXXP/72V
 - AC-XXXP/72XV
 - AC-XXXP/72S
 - AC-XXXP/72X
 - AC-XXXMH/144S
 - AC-XXXM/72V
 - AC-XXXM/72XV
 - AC-XXXMH/144V
 - AC-XXXM/72S
 - AC-XXXM/72X
- ▶ UL/NRTL Listed Boviet Modules:
 - BVM6612M 72-Cell Mono
- ▶ UL/NRTL Listed Canadian Solar Inc. Modules:
 - CS6U-xxx
 - CS6K-xxx
 - CS6X-xxx
 - CS6P-xxx
 - CS3K-xxxP
 - CS3K-xxxMS
 - CS3U-xxxP
 - CS3U-xxxMS
 - CS3W-xxxP
 - CS3U-xxxPB-AG
 - CS3U-xxxMB-AG
 - CS3W-xxxPB-AG
 - CS1H-xxxMS
- ▶ CONTINUED - Canadian Solar Inc Modules:
 - CS6K-xxxM
 - CS6K-P-FG DYMOND
 - CS1Y-xxxMS
 - CS3N-xxxMS
- ▶ UL/NRTL Listed CertainTeed Modules:
 - CTXXXHC11-04
 - CTXXXHC00-04
 - CTxxxHC11-06
- ▶ UL/NRTL Listed ET Solar Modules:
 - ET-M660xxxBB
- ▶ UL/NRTL Listed Hansol Modules:
 - UB-AN1 Black 270-300
 - UBAN1 Silver 270-300
 - UD-AN1 330-360
- ▶ UL/NRTL Listed Hanwha Q Cells Modules:
 - Q.PEAK- G4.1/MAx xxx
 - Q.PEAK BLK G4.1 xxx
 - Q.PRO G4 xxx
 - Q.PLUS G4 xxx
 - Q.PEAK-G4.1/TAA xxx
 - Q.PEAK BLK G4.1/TAA xxx
 - Q.PLUS BFR G4.1/TAA xxx
 - Q.PLUS BFR G4.1/MAx xxx
 - B.LINE PLUS BFR G4.1 xxx
 - B.LINE PRO BFR G4.1 xxx
 - Q.PEAK DUO-G5 xxx
 - Q.PEAK DUO BLK-G5 xxx
 - Q.PEAK DUO-G8 xxx
 - Q.PEAK DUO BLK-G8 xxx
 - Q.PEAK DUO-G7 xxx
 - Q.PEAK DUO BLK-G7 xxx
 - Q.PEAK DUO G7.2 xxx
 - Q.PEAK DUO-G6 xxx
 - Q.PEAK DUO BLK-G6 xxx
 - Q.PEAK DUO BLK-G6+ xxx
 - Q.PEAK DUO-G6+ xxx
 - Q.PEAK DUO-G8+ xxx
 - Q.PEAK DUO BLK-G8+ xxx
 - Q.PEAK DUO L-G8.3 xxx
 - Q.PEAK DUO L-G8.2 xxx
 - Q.PEAK DUO L-G8.1 xxx
 - Q.PEAK DUO L-G8 xxx
 - Q.PEAK DUO L-G7.3 xxx
 - Q.PEAK DUO L-G7.2 xxx
 - Q.PEAK DUO L-G7.1 xxx
 - Q.PEAK DUO L-G7 xxx
- ▶ CONTINUED - Hanwha Q Cells Modules:
 - Q.PEAK DUO L-G6 xxx
 - Q.PEAK DUO L-G6.2 xxx
 - Q.PEAK DUO L-G6.3 xxx
 - Q.PLUS DUO L-G5 xxx
 - Q.PLUS DUO L-G5.1 xxx
 - Q.PLUS DUO L-G5.2 xxx
 - Q.PLUS DUO L-G5.3 xxx
 - Q.PEAK DUO L-G5.2 xxx
 - Q.PEAK DUO L-G5.3 xxx
 - Q.PEAK L-G4.2 xxx
 - Q.PEAK L-G4.1 xxx
 - Q.PLUS L-G4.2 xxx
 - Q.PLUS L-G4.1 xxx
 - Q.PLUS L-G4 xxx
 - Q.PEAK DUO BLK G6+/SC xxx
 - Q.PEAK DUO G5/SC xxx
 - Q.PEAK DUO BLK G5/SC xxx
 - Q.Plus BFR-G4.1xxx
 - Q.Pro BFR-G4.1xxx
 - Q.Pro-G4.1/SCxxx
 - Q.PLUS BFR G4.1 xxx
 - Q.PRO BFR G4 xxx
 - Q.PRO BFR G4.1 xxx
 - Q.PRO BFR G4.3 xxx
 - Q.PEAK-G4.1 xxx
 - Q. PEAK DUO BLK G6+/TS XXX
 - Q.PEAK DUO G5/TS-XXX
 - Q.PEAK DUO BLK G6/TS XXX
 - Q.PEAK DUO G6/TS-XXX
 - Q.PEAK DUO G6+/TS-XXX
 - Q.PEAK DUO ML-G9 XXX
 - Q.PEAK DUO ML-G9.2 XXX
 - Q.PEAK DUO ML BLK-G9 XXX
 - Q.PEAK DUO ML BLK-G9.2 XXX
 - Q.PEAK DUO ML BLK-G9.3 XXX
 - Q.PEAK DUO XL -G9.3 XXX
 - Q.PEAK DUO ML -G9.3 XXX
 - Q.PEAK DUO ML BLK -G9.3 XXX
 - Q.PEAK DUO ML BLK -G9.3 XXX
 - Q.PEAK DUO ML -G9 XXX
 - Q.PEAK DUO ML -G9+ XXX
 - Q.PEAK DUO BLK ML -G9+ XXX
 - Q.PEAK DUO BLK ML -G9 XXX
- ▶ UL/NRTL Listed Hyundai Modules:
 - HiS-MxxxMG
 - HiS-MxxxMI

▶ CONTINUED - Hyundai Modules:

- HiS-MxxxTI
- HiS-MxxxRI
- HiS-SxxxRI
- HiS-MxxxRG

▶ UL/NRTL Listed Itek Modules

- IT-xxx-SE
- Hipro TP672M-xxx

▶ UL/NRTL Listed JA Solar Modules:

- JAP6[DG]
- JAM6[K]-60-xxx/4BB

▶ UL/NRTL Listed Jinko Solar Modules::

- JKMxxxPP-72-DV
- JKMxxxPP-60-DV
- JKMxxxM-60HBL
- JKMxxxM-72HL-V
- JKMxxxM-72HL-TV
- JKMxxx-P-60
- JKMxxxM-72HL4-TV
- JKMxxxM-6RL3-B

▶ UL/NRTL Listed Kyocera Modules:

- KUxxxMCA

▶ UL/NRTL Listed LG Electronics Inc. Modules:

- LGxxxS1C-G4
- LGxxxN1C-G4
- LGxxxS2WG4
- LGxxxN1K-G4
- LGxxxN2W-G4
- LGxxxN1K-A5
- LGxxxQ1C-V5
- LGxxxQ1K-V5
- LGxxxN2W-A5
- LGxxxS2W-A5
- LGxxxN2T-A5
- LGxxxQ1C-A5
- LGxxxQ1K-A5
- LGxxxN2W-V5
- LGxxxN1C-V5
- LGxxxN1W-V5
- LGxxxN1K-V5
- LGXXXN2W-V5
- LGXXXN1C-V5
- LGXXXN1W-V5
- LGXXXN1K-V5
- LGXXXN2T-V5
- LGXXXN1C-N5

▶ CONTINUED - LG Electronics Inc. Modules:

- LGXXXQ1C-N5
- LGXXXQ1K-N5
- LGXXXN1K-L5
- LGXXXN2W-L5
- LGXXXN2T-L5
- LGXXXN1W-L5
- LGXXXN1T-L5
- LGXXXA1C-V5
- LGXXXA1K-V5
- LGXXXM1C-N5
- LGXXXM1K-L5
- LGXXXQ1C-A6
- LGXXXQ1K-A6
- LGXXXQAC-A6
- LGXXXQAK-A6
- LGXXXN1C-A6
- LGXXXN1K-A6
- LGXXXN2W-E6
- LGXXXN2W-E6.AW5
- LGXXXN2T-E6
- LGXXXN1K-B6
- LGXXXQ1C-A6
- LGXXXQ1K-A6
- LGXXXQAC-A6
- LGXXXQAK-A6
- LGXXXN1C-A6
- LGXXXN1K-A6
- LGXXXN2W-E6
- LGXXXN2W-E6.AW5
- LGXXXN2T-E6
- LGXXXN1K-B6
- LGXXXA1C-A6
- LGXXXM1C-A6
- LGXXXM1K-A6
- LGxxxN16-E6

▶ UL/NRTL Listed Longi Modules:

- LR6-72-xxxM [xxx=320-350]
- LR6-72HV-xxxM [xxx=320-350]
- LR6-72BK-xxxM [xxx=320-350]
- LR6-72PE-xxxM [xxx=340-380]
- LR6-72PH-xxxM [xxx=340-380]
- LR6-72PB-xxxM [xxx=340-380]
- LR6-72HPB-xxxM [xxx=360-385]
- LR6-60-xxxM [xxx=270-300]
- LR6-60HV-xxxM [xxx=270-300]
- LR6-60BK-xxxM [xxx=270-300]
- LR6-60PE-xxxM [xxx=280-320]
- LR6-60PH-xxxM [xxx=280-320]
- LR6-60PB-xxxM [xxx=280-320]

▶ CONTINUED - Longi Modules:

- LR6-72BP-xxxM
- LR6-60BP-xxxM
- LR6-72HBD-xxxM
- LR6-60-xxxM
- LR6-60BK-xxxM
- LR6-60PE-xxxM
- LR6-60PB-xxxM
- LR6-60PH-xxxM
- LR6-60HPB/HIB-xxxM
- LR6-60HPP/HIH-xxxM
- LR6-72-xxxM
- LR6-72BK-xxxM
- LR6-72HV-xxxM
- LR6-72PE-xxxM
- LR6-72PB-xxxM
- LR6-72PH-xxxM
- LR6-72HPP/HIH-xxxM
- LR6-72BP-xxxM
- LR6-72HBD/HIBD-xxxM
- LR6-60BP-xxxM
- LR6-60HBD/HIBD-xxxM
- LR4-60HPP/HIH-xxxM
- LR4-60HPB/HIB-xxxM
- LR4-72HPP/HIH-xxxM
- LR4-72HBD/HIBD-xxxM
- LR4-72HBD/HIBD-xxxM

▶ UL/NRTL Listed Lumos Modules:

- LSxxxx-60M-B/C

▶ UL/NRTL Listed Luxor Solar Modules:

- Lx-xxxP
- Lx-xxxM

▶ UL/NRTL Listed Mission Solar Modules:

- MSExxxSB1J
- MSExxxS05T
- MSExxxS04J
- MSExxxSQ6S
- MSExxxS06J
- MSExxxSQ4S
- MSExxxSQ5T
- MSExxxSQ5K
- MSExxxSQ8T
- MSExxxSQ8K
- MSExxxSQ9J
- MSExxxSQ9S
- MSExxxSR8T
- MSExxxSR8K

Compatible Modules continued

K2's CrossRail System was tested with the following:

- ▶ CONTINUED - Mission Solar Modules:
 - MSExxxSR9S
 - MSExxxSB1J
 - MSExxxSX5T
 - MSExxxSX5K
 - MSExxxSX6S
 - MSExxxSX6W
 - MSExxxSX6Z
 - MSExxxSX5R
- ▶ UL/NRTL Listed Panasonic Modules:
 - VBHNxxxSA16
 - VBHNxxxKA01
 - VBHNxxxKA03
 - VBHNxxxKA04
 - VBHNxxxSA17
 - VBHNxxxSA18
 - VBHNxxxSA17E
 - EVPVxxx
 - EVPVxxxK
- ▶ UL/NRTL Listed Peimar Modules:
 - SGxxxP-[BF]
 - SGxxxP
 - SGxxxM-[BF]
 - SGxxxM
- ▶ UL/NRTL Listed Phono Solar Modules:
 - PSxxxMG-20/U
 - PSxxxPG-20/U
 - PSxxxM-20/U
 - PSxxxMH-20/U
- ▶ UL/NRTL Listed Prism Solar Modules:
 - Bi48 xxx Bifacial
 - Bi60 xxx Bifacial
- ▶ UL/NRTL Listed REC Modules:
 - RECxxxTP2 BLK2
 - RECxxxTPS 72
 - RECxxxTP2S 72 XV
 - RECxxxTP2SM 72 XV
 - RECxxxTP2SM 72
 - RECxxx NP
 - RECxxx NP Black
 - RECxxxAA
 - RECxxxAA Black
 - RECxxxTP4
 - RECxxxAAPure
 - RECxxxTP4Black
- ▶ UL/NRTL Listed Sanyo Electric Co Ltd of Panasonic Group Modules:
 - VBHNxxxSA16
 - VBHNxxxSA17
 - VBHNxxxSA18
 - VBHNxxxSA16
 - VBHNxxxSA17
 - VBHNxxxSA18
 - VBHNxxxKA01
 - VBHNxxxKA03
 - VBHNxxxKA04
- ▶ UL/NRTL Listed Seraphim Modules:
 - SEG-XXX-6MA-HV
 - SEG-XXX-BMA-HV
- ▶ UL/NRTL Listed Silfab Modules:
 - SLAxxxM
 - SLG-M-xxx
 - SLA-x-xxx
 - SLG-x-xxx
 - SIL-xxx BL
 - SIL-xxx HL
 - SIL-xxx NL
 - SIL-xxx ML
 - SIL-xxx NT
 - SIL-xxx BK
 - SIL-xxx NU
 - SIL-xxx NX
 - SIL-xxxHC
- ▶ UL/NRTL Listed Sharp Modules:
 - NU-SCxxx
 - NU-SAxxx
- ▶ UL/NRTL Listed Solaria Modules:
 - PowerxT® -xxxR-PD
 - PowerxT® -xxxR-BD
 - PowerxT® XXXR-PM
- ▶ UL/NRTL Listed Solarworld Modules "Sunmodule":
 - Plus SW XXX Mono
 - Plus SW XXX Poly
- ▶ UL/NRTL Listed Soluxtec Modules:
 - FR xxx Wp
 - Power Slate 54 Mono Dark Series
 - Power Slate 54 Mono Series
- ▶ UL/NRTL Listed SunPower Modules:
 - SPR-E19-xxx
 - SPR-E20-xxx
- ▶ UL/NRTL Listed Sunprime Modules:
 - GxB-xxx
 - GxB-xxxSM
 - GxB-xxxSL
- ▶ UL/NRTL Listed Sunspark Modules:
 - SST-275-300M
 - SMX-250-265P
 - SST-xxxM 60 cell
 - SST-xxxM 72 cell
 - SST-xxxMB 60 cell
 - SST-XXXM3B-60/72
 - SST-XXXM3-60/72
 - SST-XXXM3B-60/72
- ▶ UL/NRTL Listed S-Energy Modules:
 - SN15-60PAE/PCE-xxxV
 - SN10-60PAE/PBE/PCE-xxxV
 - SN15-60MAE/MCE-xxxV
 - SN10-60MAE/MCE-xxxV
 - SNxxxM-10T[SN60]
 - SN15-72PAE/PCE-xxxV
 - SN10-72PAE/PBE/PCE-xxxV
 - SN15-72MAE/MCE-xxxV
 - SN10-72MAE/MBE/MCE-xxxV
 - SN20-60MAE/MBE/MCE-xxxV
 - SN25-60MAE/MCE-xxxV
 - SC20-60MAE/MBE/MCE-xxxV
 - SC25-60MAE/MCE-xxxV
 - SN20-72MAE/MBE/MCE-xxxV
 - SN25-72MAE/MCE-xxxV
 - SC20-72MAE/MBE/MCE-xxxV
 - SC25-72MAE/MCE-xxxV
 - SD25-60BDE-xxxV
 - SD25-72BDE-xxxV
- ▶ UL/NRTL Listed Talesun Modules:
 - Hipro TP660M-xxx
 - Hipro TP672M-xxx
- ▶ UL/NRTL Listed Trina Solar Modules:
 - TSM-xxxDE14A
 - TSM-xxxDD05A.08
 - DUOMAX SPECS 1. PEG14
 - DUOMAX SPECS 2. PEG5
 - DUOMAX SPECS 3. PEG5.07
 - DUOMAX SPECS 4. PDG5



▶ CONTINUED - Trina Solar Modules:

- TSM-DE15H(II)
- TSM-DE15M(II)
- TSM-DD06M.05(II)
- TSM-DD06H.05(II)
- TSM-DD06M.t5(II)
- TSM-DD06H.T5(II)
- TSM-PE15H
- TSM-DEG15HC.20(II)
- TSM-DEG15MC.20(II)
- TSM-DEG6HC.20(II)
- TSM-DEG6MC.20(II)
- TSM-xxxDE15V(II)
- TSM-xxxDE19
- TSM-xxxDEG15VC.20(II)
- TSM-xxxDEG19C.20

▶ UL/NRTL Listed V Energy Modules:

- Series 200 PV

▶ UL/NRTL Listed Yingli Solar Modules:

- YL-xxxP-29b
- YL-xxx-35b

Notes

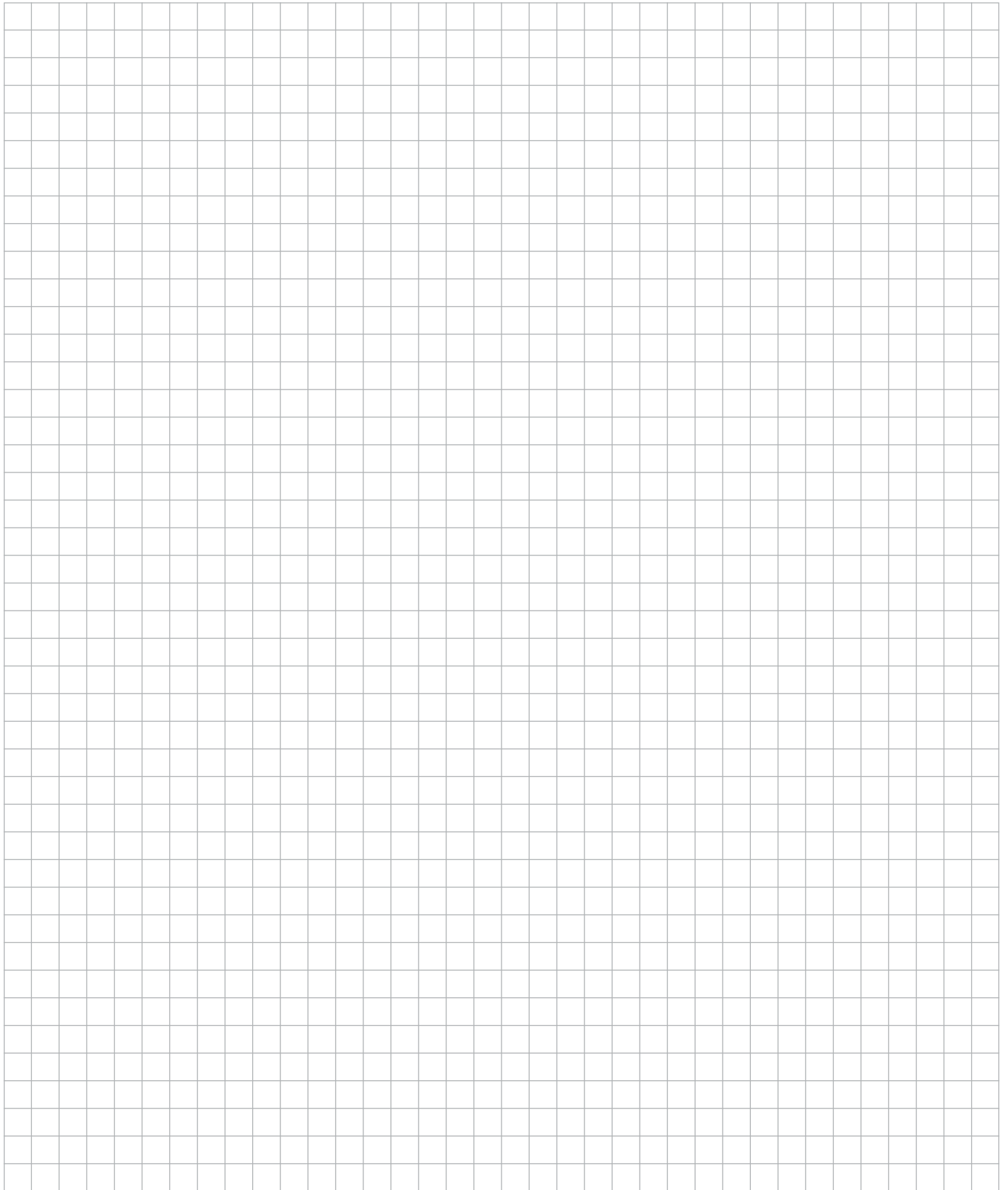



Thank you for choosing a K2 mounting system.

Systems from K2 Systems are quick and easy to install. We hope these instructions have helped. Please contact us with any questions or suggestions for improvement.

Our contact info:

- ▶ k2-systems.com/en-US/contact
- ▶ Telephone: +1.760.301.5300

K2 Systems

4665 North Ave, Suite I
Oceanside, CA 92056
USA

+1.760.301.5300
info-us@k2-systems.com
www.k2-systems.com