

Corrugated PowerClamp, Kit

QUICK GUIDE

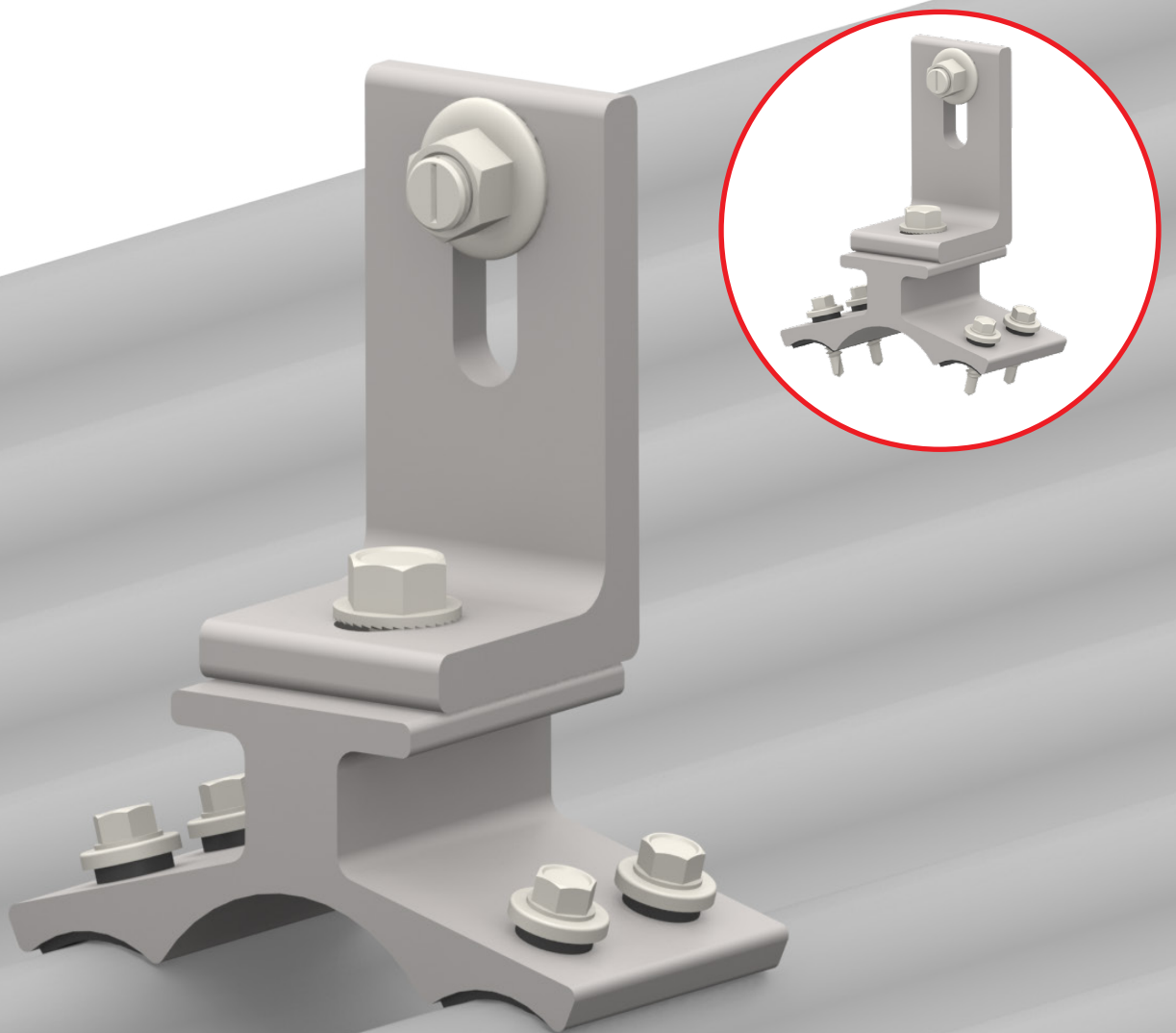

Product Kit & Components

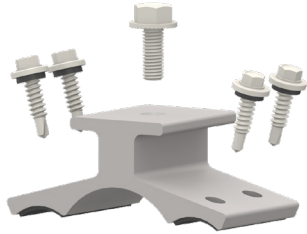

Part Number	Description
4000305	Corrugated PowerClamp



Part Number	Description
4000630	L-Foot Slotted Set, Mill

Tools overview



10-50 ft-lb



13 mm deep socket

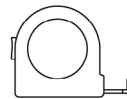

Measurement Tape

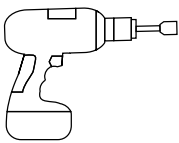

5/16" Nut Driver



Stringline



Caulk gun

Assembly Onto Roof

1

- ! Measure up from the eave of the roof and mark where you will install each row of Corrugated PowerClamps. Perform this step on both the East and West edge of your array.

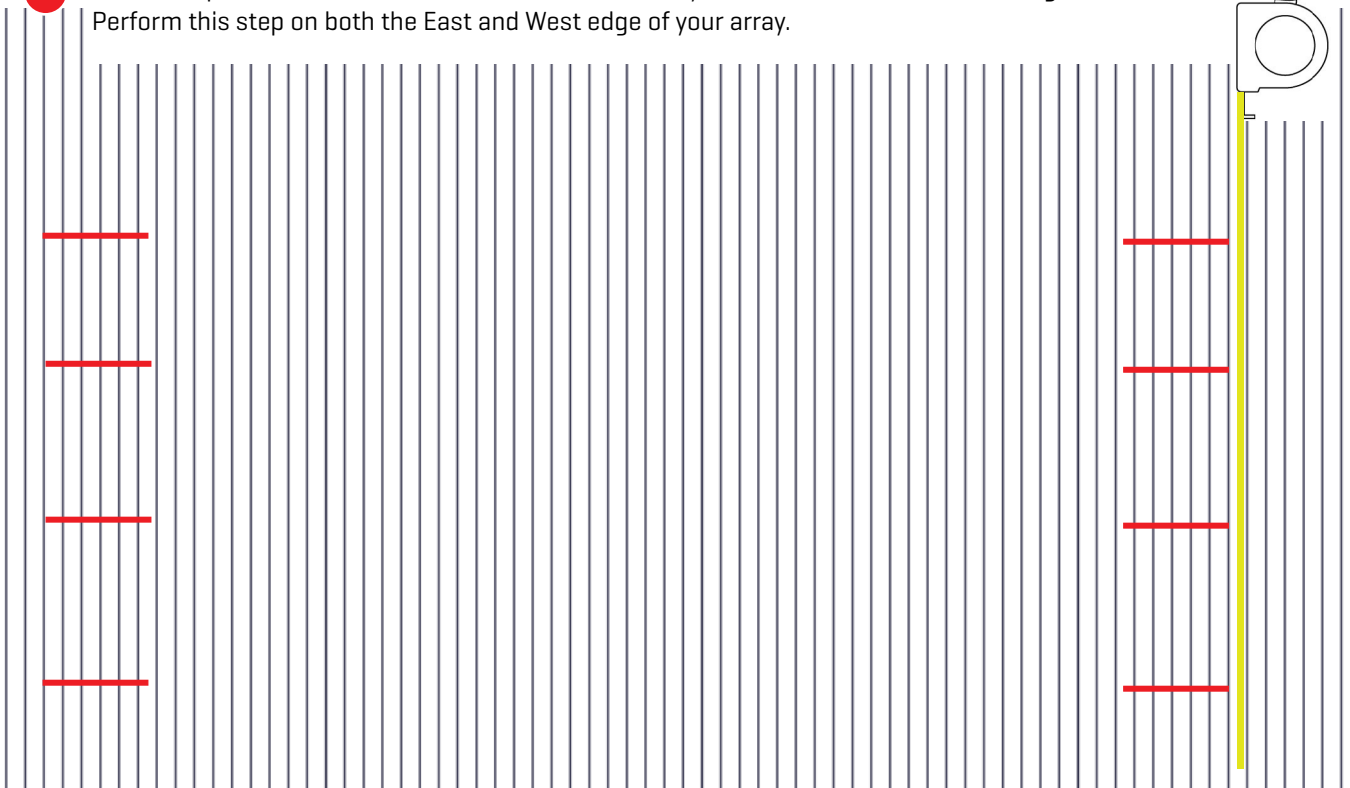

2

- ! Place the first powerclamps on your marks made on the outside edges of the array. Install the powerclamp using 4 self tapping screws fastened through the pre-punched holes, EPDM gasket, and into the peaks of the corrugated roof panel. Do not over torque screws as you risk stripping the tapped hole in the roof and damaging the sealing washer. Proper torque is achieved when the screw's EPDM sealing washer sits flush.

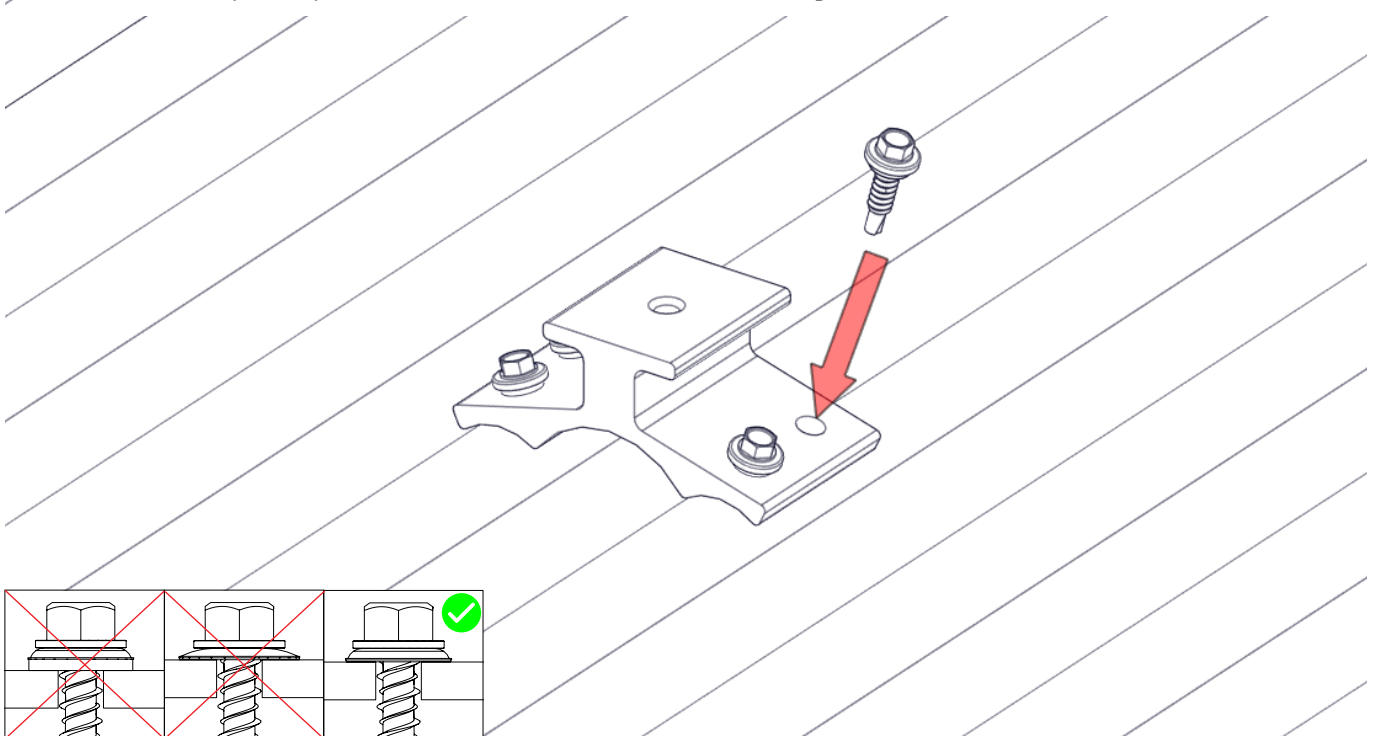

3

Run a stringline between the outer edge Corrugated PowerClamps within the same row. Using the stringline as a guide to locate your mounts, install the rest of the mounts within the row. Repeat this process for each row of mounts.

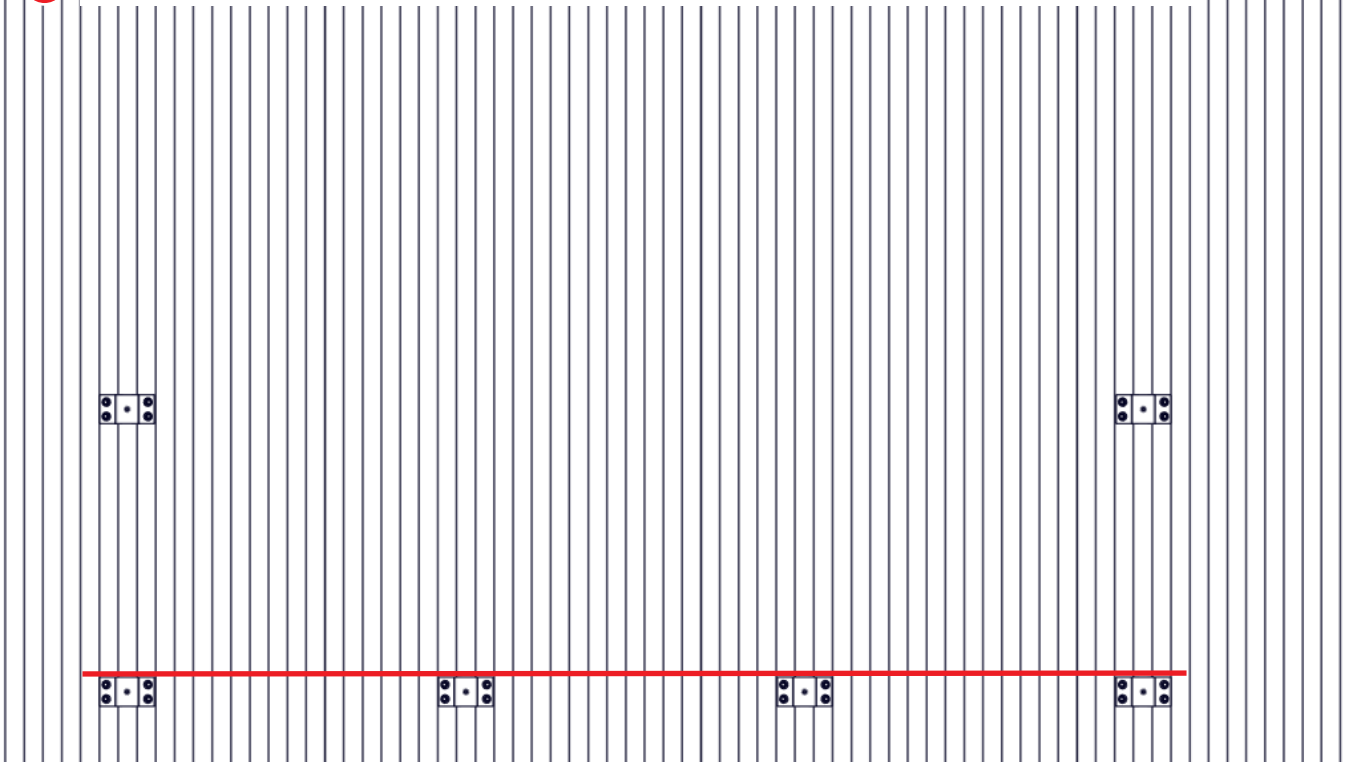

4

Using an approved metal roofing sealant, apply a bead of sealant around the entire perimeter of the mount.

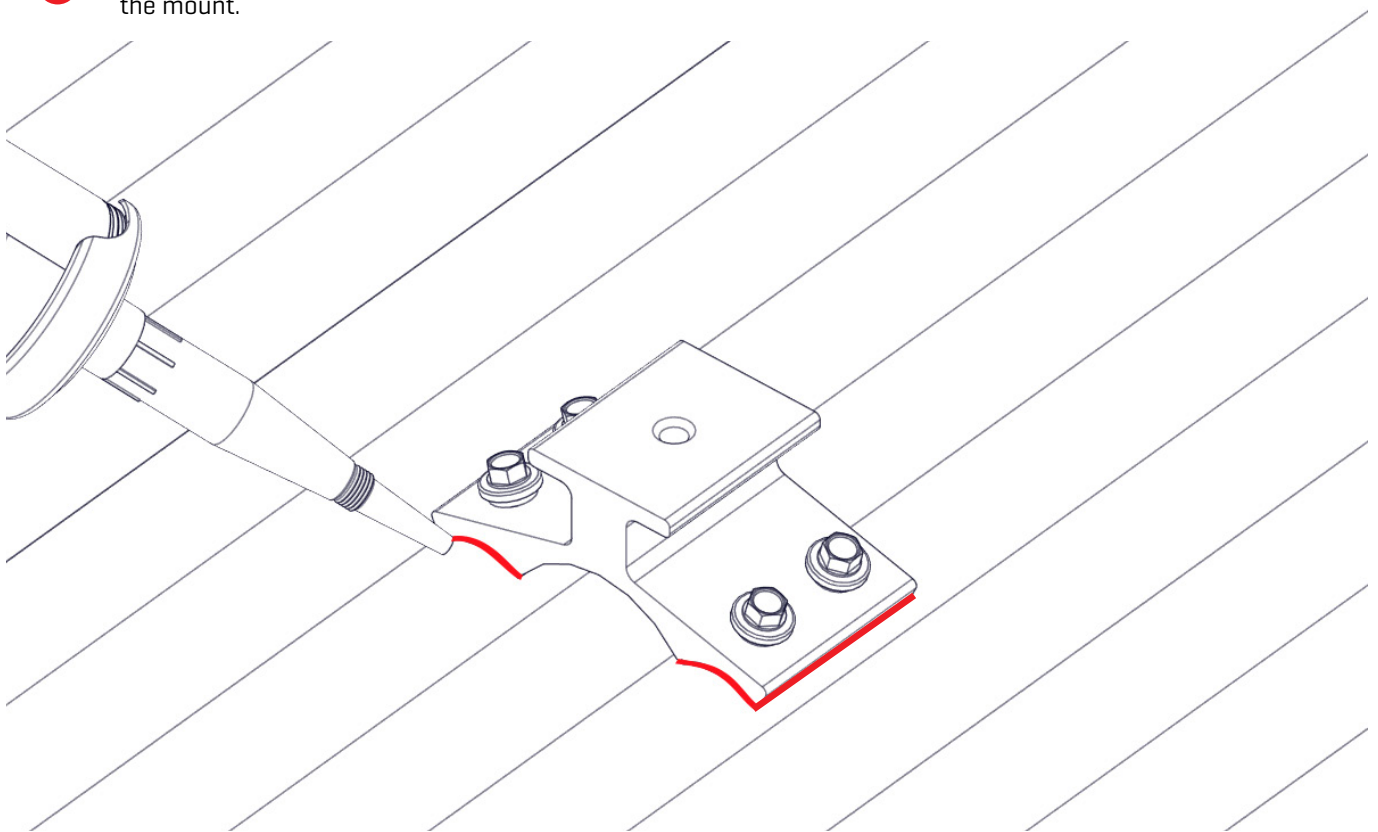

5

- ! Attach the L-foot to the top of the Corrugated PowerClamps using the provided M8 serrated flange bolt. Tighten the M8 bolt to 16.5 ft-lbs [22.4 Nm].

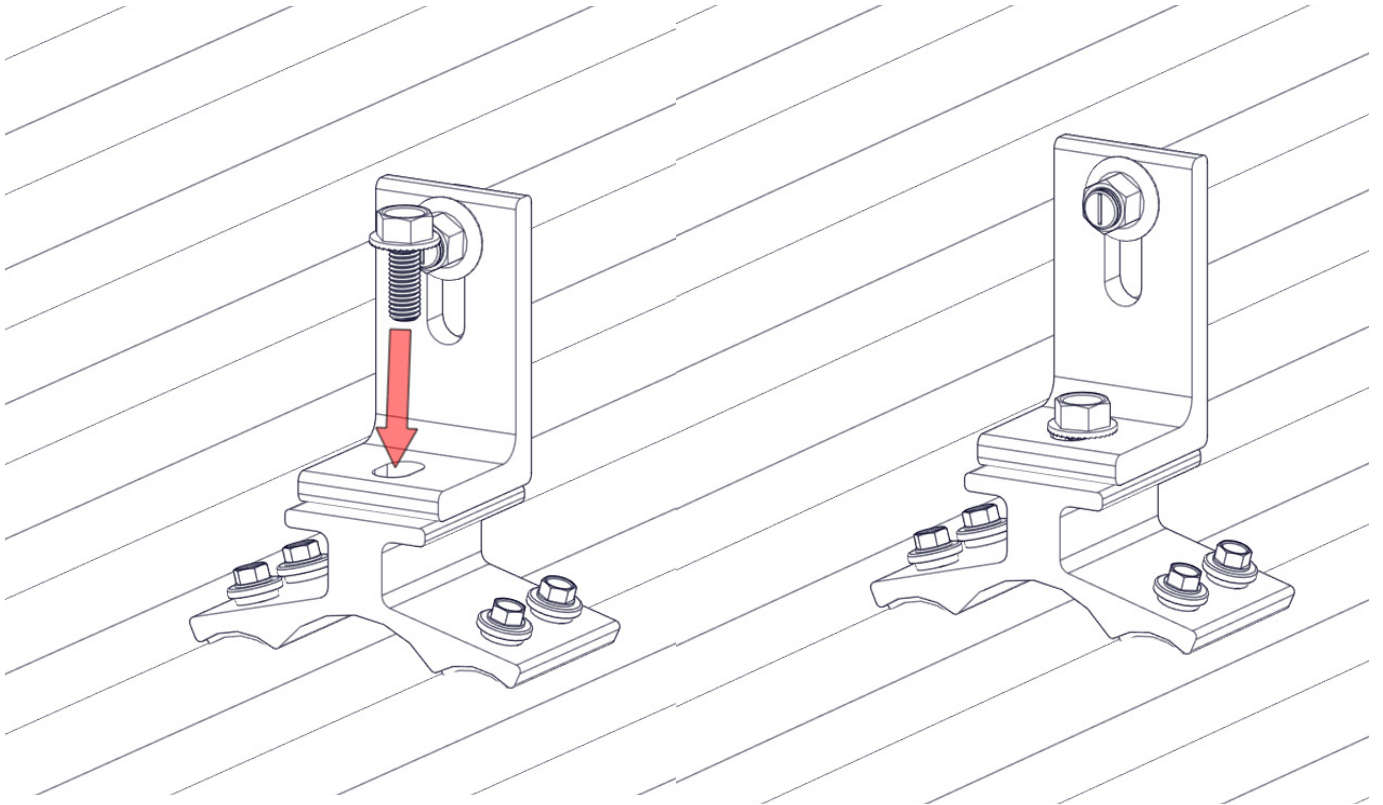

6

- ! Repeat step 5 until you have all your L-feet secured and aligned straight on the Corrugated PowerClamps.

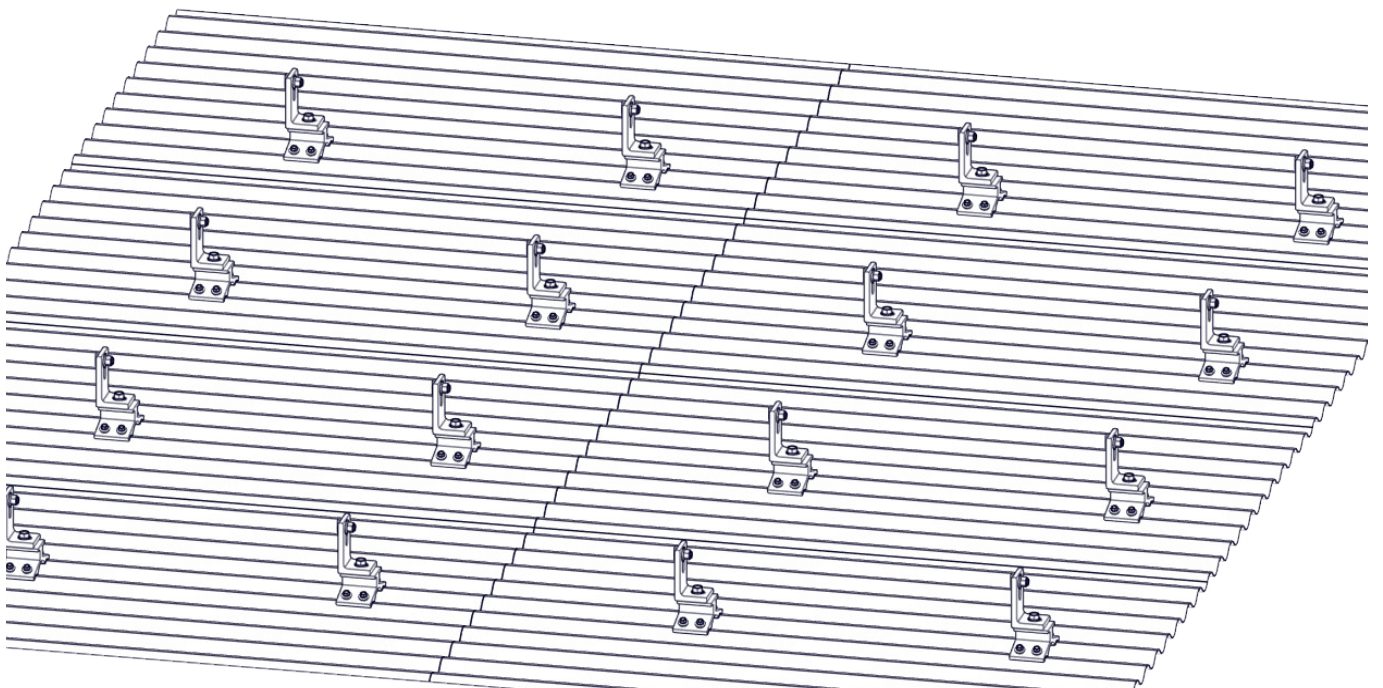



Thank you for choosing a K2 mounting system.

Systems from K2 Systems are quick and easy to install. We hope these instructions have helped. Please contact us with any questions or suggestions for improvement.

Our contact info:

▶ k2-systems.com/en-US/contact

▶ Telephone: +1.760.301.5300

K2 Systems LLC

2835 La Mirada Drive, Suite A

Vista, CA 92081

USA

+1.760.301.5300

info@k2-systems.com

www.k2-systems.com

