

# Big Foot

## QUICK GUIDE

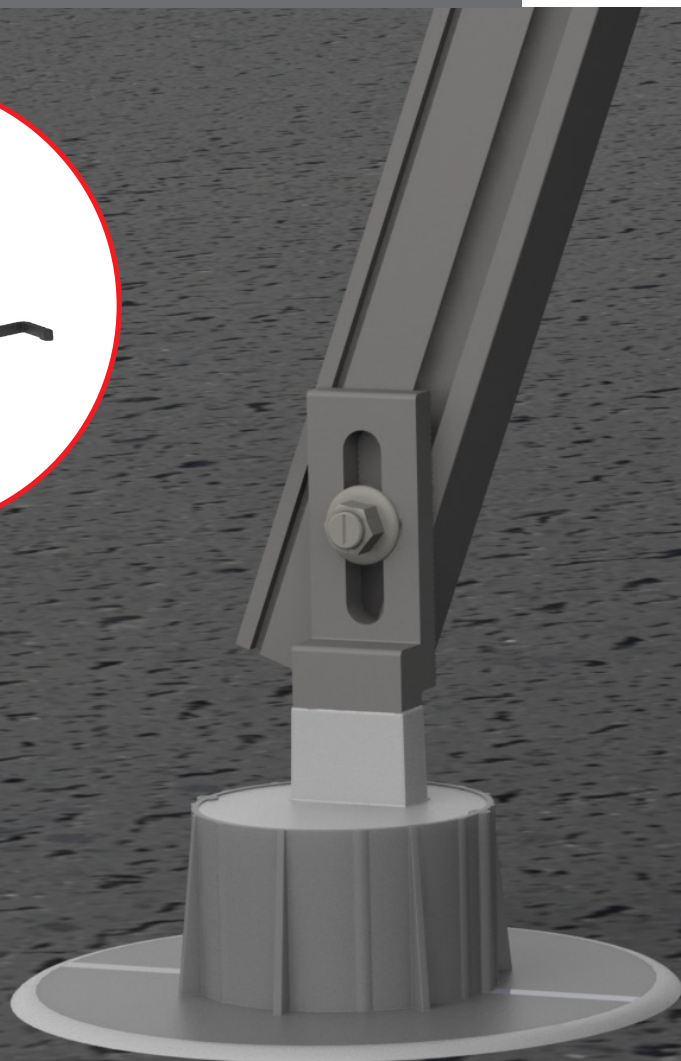

# Components

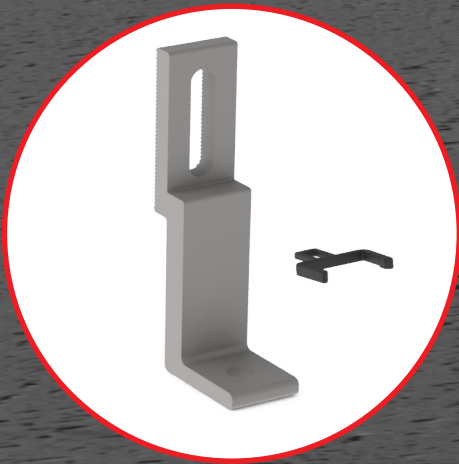

Part Number	Description
4000218	Big Foot 6" w/ 3"+ Chem Link Clip

Kit includes:



**Big Foot**  
Material: aluminum



**Chem Link Clip**  
Material: polyimide

Optional components:



**ChemLink 3" E-Curb Kit**  
E-Curb  
M-1 structural adhesive/sealant  
1-Part moisture cure pourable sealant

# Tools overview

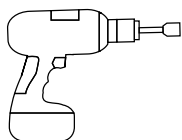
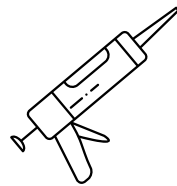
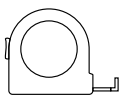

Torque wrench  
▶ 10-50 ft-lbs



13 mm deep socket

# Assembly



1

! Choose the appropriate fasteners for your structural attachment. If needed, drill your pilot holes, seal holes, and secure the Big Foot to the roof.

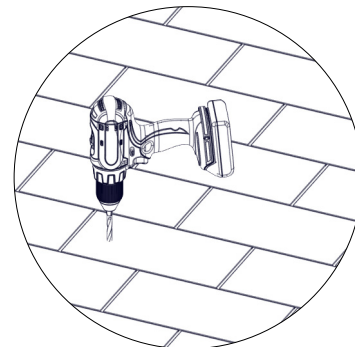
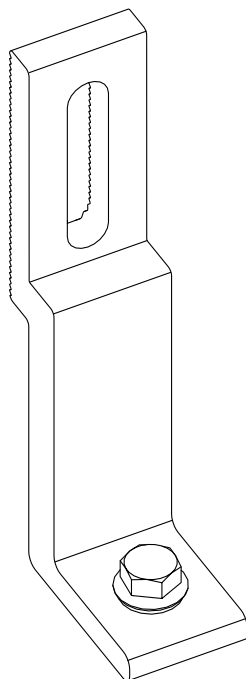

2

! Attach the Chem Link Clip on the bottom half of the foot. This is used to ensure proper distance when installing the Chem Link E-Curb. The back of the clip should hit the wall of the E-Curb.

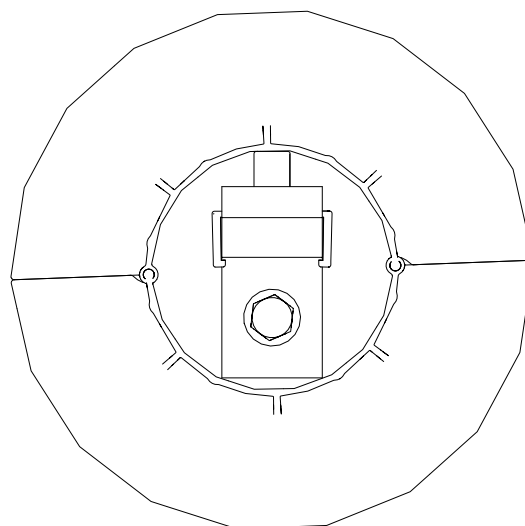
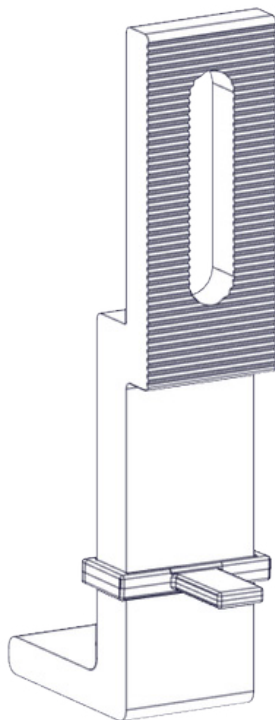

3



Follow ChemLink E-Curb installation manual for detailed steps.

Using Chem Link's M-1, seal the base of the Big Foot covering the base of the mount including the lag screw. M-1 sealant should coat the entire mount from the roof to 3" above the top of the E-Curb rim.

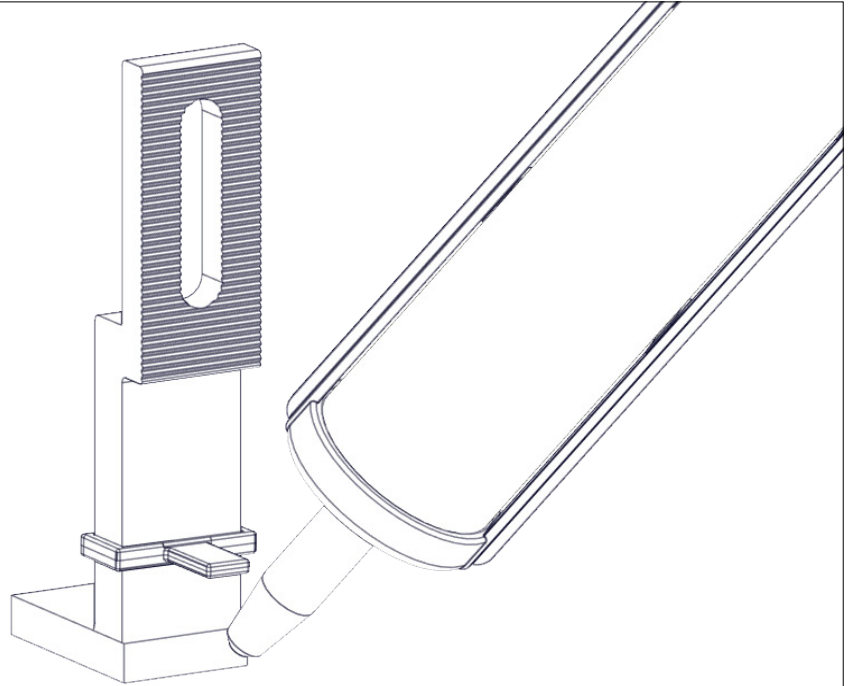

4



Following ChemLink's E-Curb instruction manual, apply 1/4" beads of M-1 on the inner, middle and outer circle to cover both sections of the bottom of the E-Curb. Carefully place the E-Curb ensuring that the inner wall is touching the Chem Link Clip. Use the ChemLink logo on the E-Curb as a guide to place the E-Curb directly in front of the bottom of the Big Foot. Press the rings firmly in place until excess adhesive extrudes from the outside edges.

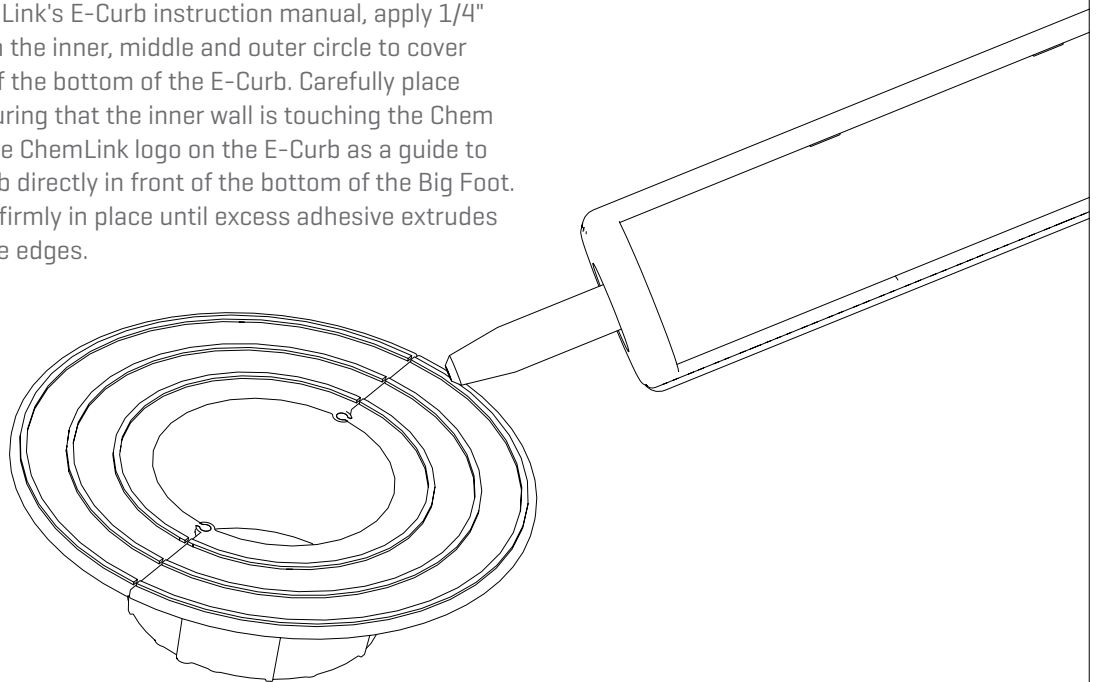

5

! Apply M-1 along the outside edge of the installed E-Curb rings and smooth it out. Also seal the connection of the two halves of the E-Curb.

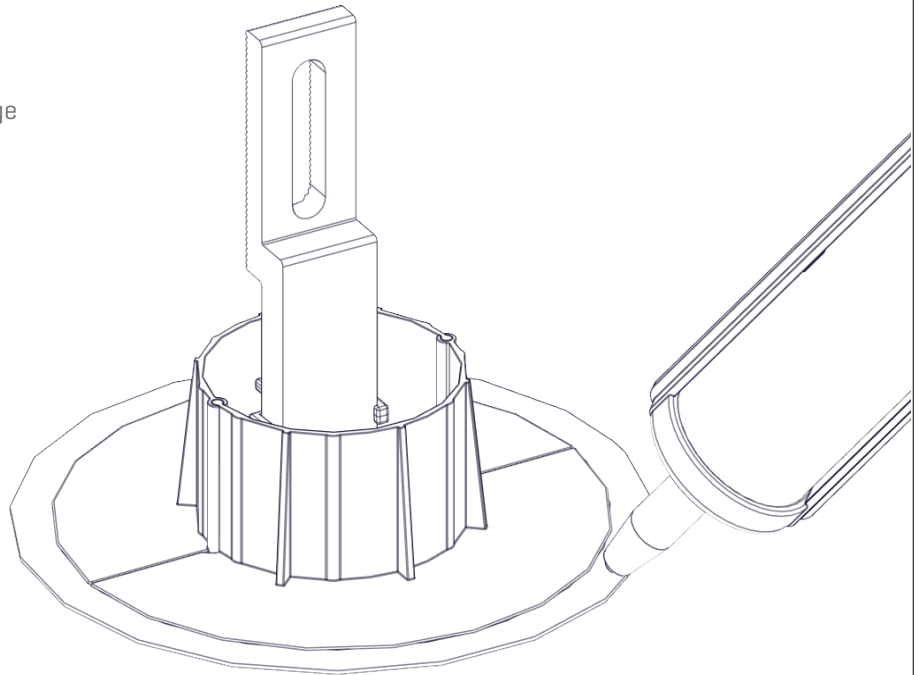

6

! Completely fill the E-Curb with ChemLink's 1-Part solution.

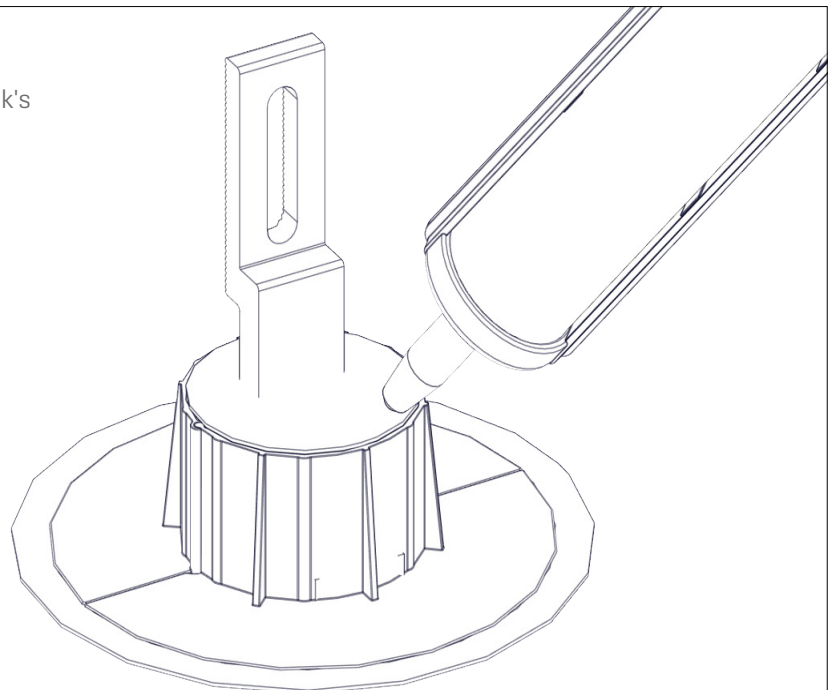

7

The CrossRail can be installed on either side of the Big Foot, but there is a built in shelf for support on the inside of the Big Foot. To install your CrossRail to the Big Foot, insert the T-Bolt through the slot and into the side channel of CrossRail. Turn the T-Bolt clockwise ensuring that the mark at the end of the shaft is vertical, indicating proper alignment. Using a 13 mm socket, tighten to 25.8 ft-lb [35 Nm]. Double check that the alignment marking on the end of the T-Bolt shaft is vertical, indicating proper alignment.

!

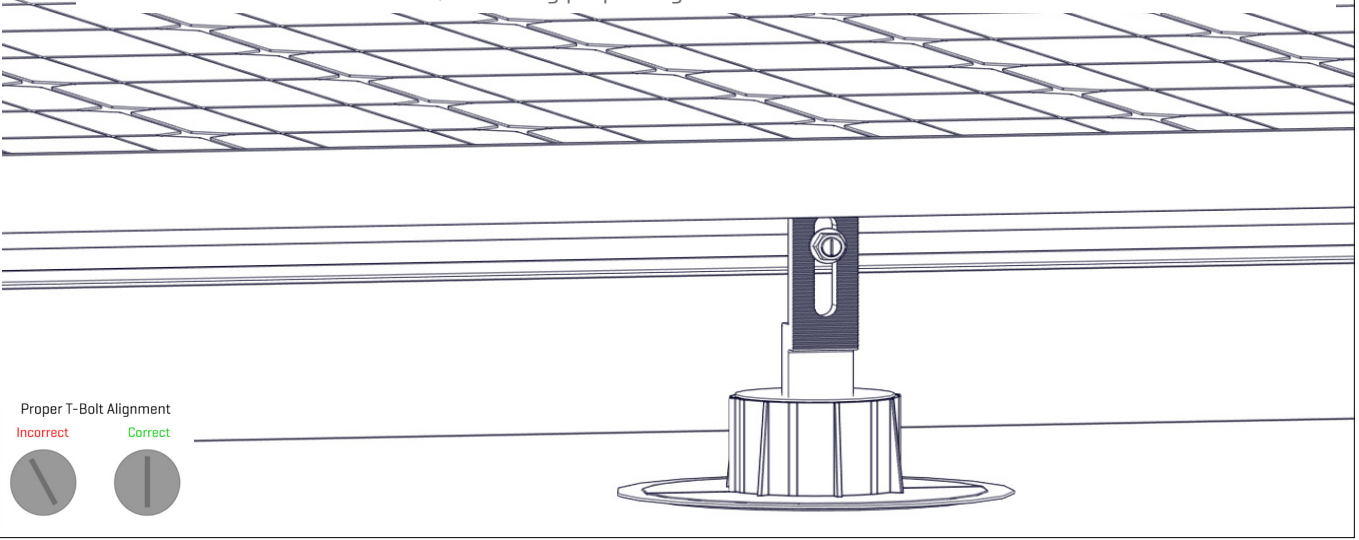

Proper T-Bolt Alignment

Incorrect

Correct

