



18K-2P-LV HYBRID INVERTER

QUICKSTART GUIDE



18K Installation QuickStart

CONTENTS

- Overview 1**
- Before You Start 2**
 - Step 1.** Confirm all items are in the box. 2
 - Step 2.** Set up MySolArk. 3
 - Step 3.** Prepare the site. 4
 - Step 4.** Mount inverter to surface with proper hardware..... 5
 - Step 4b.** Install the LCD Sunshade (outside installations only) 6
- Inverter Wiring 7**
 - Step 5.** Connect inputs and outputs. 7
 - Step 6.** Check wiring area. 8
 - Step 7.** Integrate batteries with Inverter. 9
 - Step 8.** Check Polarity and Voltage. 10
 - Step 9.** Connect Battery Cables 11
 - Step 10.** Turn inverter ON. 12
- Set Up Batteries 13**
 - Step 11.** Set up battery communications. 13
 - Step 12.** Check battery communications. 14
- Check Inverter Setup 15**
 - Step 13.** Check PV wiring polarity. 15
 - Step 14.** Confirm Grid AC Voltage. 17
 - Step 15.** Check Grid Parameters. 18
 - Step 16.** Check Load AC voltage. 19
 - Step 17.** Test Island Mode. 20

18K Installation QuickStart

Set Up WiFi	21
Step 18. Connect the Dongle.	21
Step 19. Create the plant.....	22
Step 20. Check LED status of Dongle.	23
Step 21. Check network stability.....	24
Step 22. Check system performance.	25
Software Updates	26
Considerations for Parallel Systems.....	27
MORE INFORMATION.....	28
Mounting the Sol-Ark (Step 4 Details).....	29
Inverter General Description (Step 5 Details).....	30
Connection Requirements (Step 7 Details)	35
Battery Communications (Step 10 Details)	37
Battery Setup screens (Step 11 Details)]	39
Connecting PV Modules (Step 13 Details)	45
Confirm Grid AC Voltage. (Step 14 Details)	47
Check Grid Parameters (Step 15 Details)	49
Test Island Mode (Step 17 Details)	53
Alternate Method for Connecting to WiFi using IP Address (Step 18 Details) .	54
Create a Plant on MySolArk (Step 19 Details)	56
System Work Modes (Step 22 Details)	58

18K Installation QuickStart

About this guide

This QuickStart guide provides the essential steps for installing a Sol-Ark inverter. This guide is divided into two parts:

- The **18K Installation QuickStart** section starting on the next page lists the basic steps you need, with a links to more detailed information in the second part of the guide.
- The **More Information** section starting on page 29 provides additional details that you might need.

For full information, see the [18K-2P-LV Installation Manual](#).

Disclaimer

This QuickStart Guide offers a brief installation and commissioning overview for the Sol-Ark 18K-2P-LV Hybrid Inverter. It is not intended to, and should not, replace the [18K-2P-LV Installation Manual](#) or to address all matters referred to in the Manual.

This product may be dangerous if improperly configured, installed or operated. You are urged to read and review the full Manual, including applicable data sheets, and to visit the Sol-Ark Knowledge Hub at www.sol-ark.com to learn more fully about this product.

The information included in this QuickStart Guide is subject to, and qualified by, the information set forth in the Manual, including important disclaimers and warnings that limit or exclude Sol-Ark's liability.

See the Commissioning and Programming sections of this QuickStart Guide for details, including advanced configurations, necessary to meet the requirements or needs for system performance.

18K Installation QuickStart

Overview

18K-2P-LV
120/240V, 120/208V

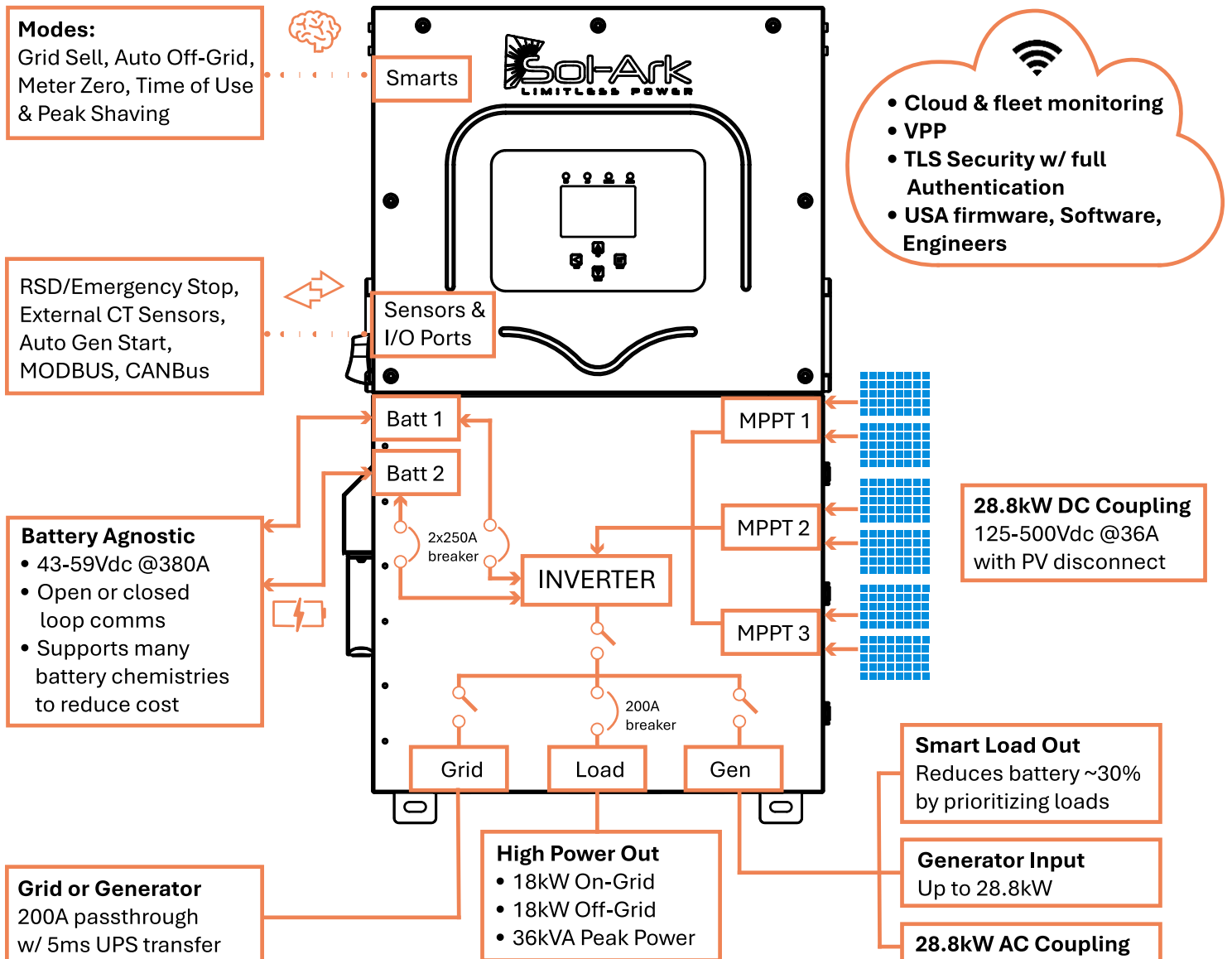

18K Installation QuickStart

Before You Start

Step 1. Confirm all items are in the box.

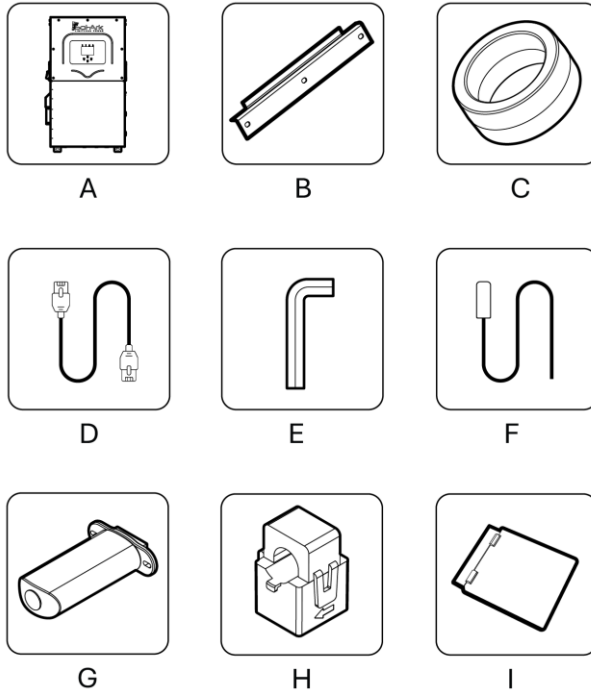

Component	Description	Quantity
A	Sol-Ark 18K-2P-inverter	1
B	Inverter Mounting Cleat	1
C	Filter Rings	10
D	CAT 5 Communication Cable for Parallel Inverters	1
E	3mm L-type hex key for front panel screws	1
F	Battery Temperature Sensor	1
G	Wi-Fi / Ethernet Gateway (dongle)	1
H	300A Current Transformers (CT sensors)	1
I	LCD Sunshade (for outside installations)	1

Other item you'll need:

Smart Phone or Laptop

18K Installation QuickStart

Step 2. Set up MySolArk.

Create a MySolArk Account (MSA) by downloading the app or visiting www.mysolark.com to access the desktop version.

MySolArk in the App Store

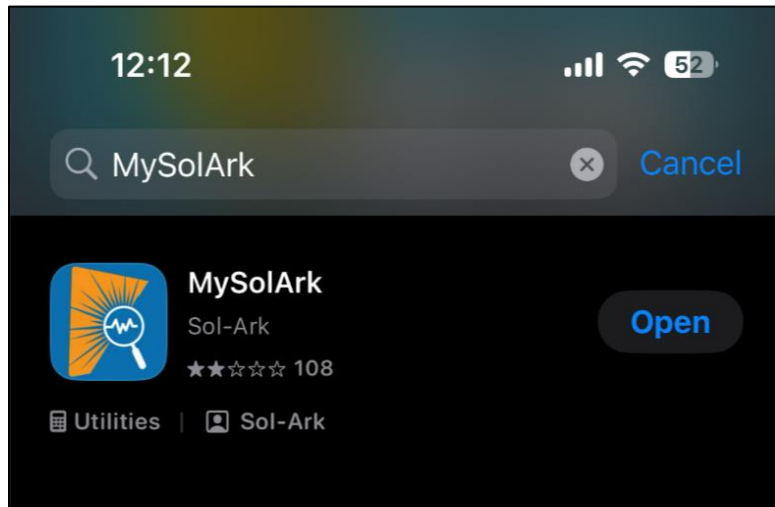

MySolArk Desktop on the Sol-Ark Website

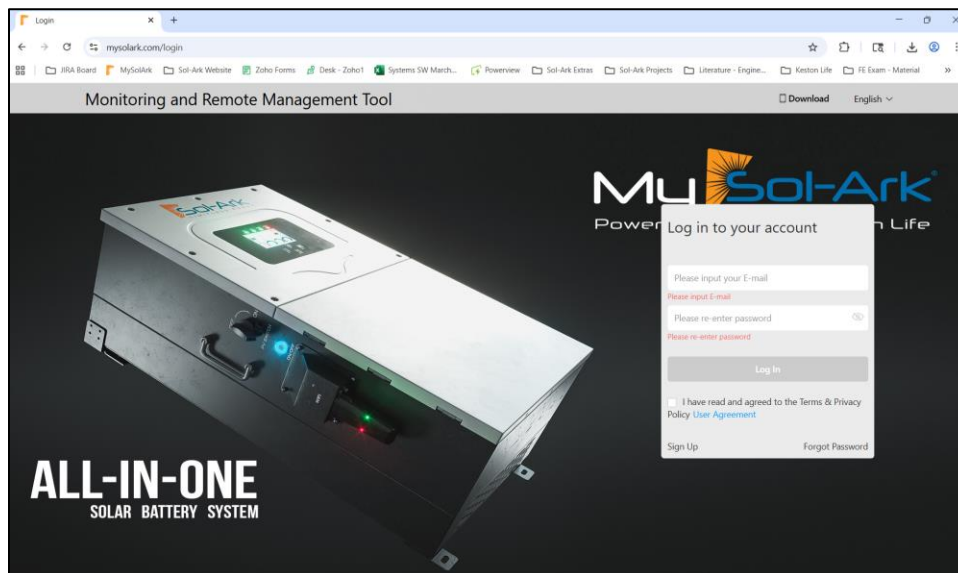

- The email used will be primary account for all created plants
- See [Step 19. Create the plant.](#) for more information.

18K Installation QuickStart

Step 3. Prepare the site.

Locate a suitable area to mount the inverter and follow these requirements:

- 6" vertical clearance
- 2" side clearance
- 6" side clearance from another system
- Protect LCD from direct exposure to UV light
- Operating temperature of -40°F to 140°F

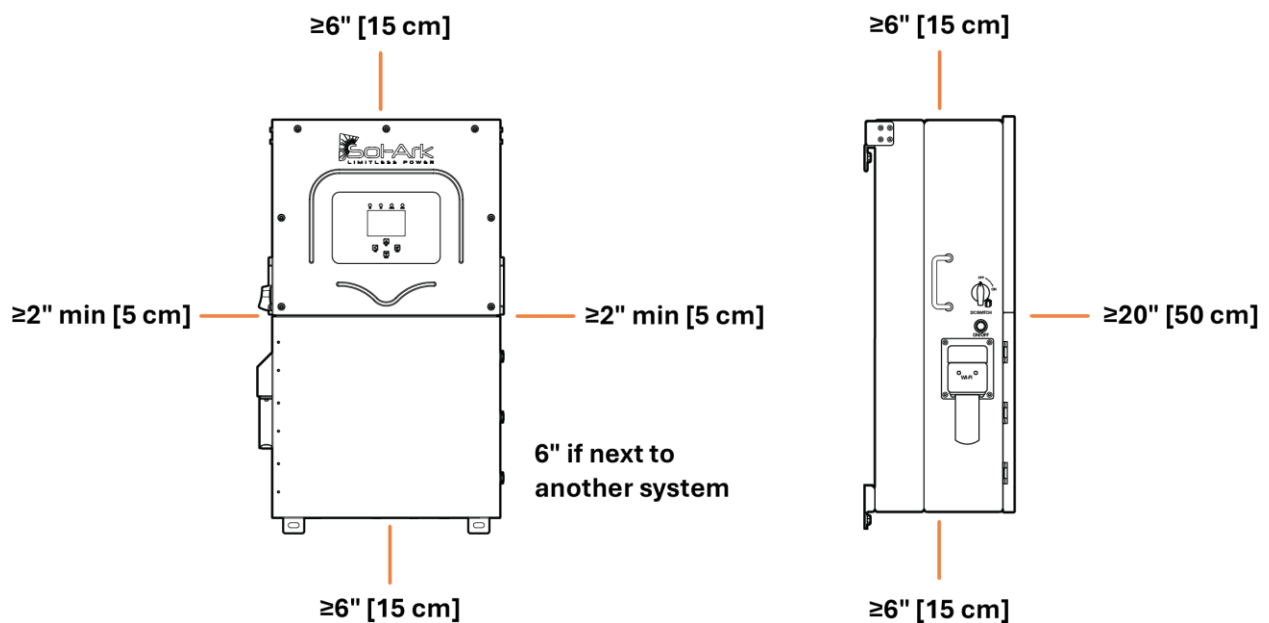

NOTE: Inverter has a Maximum Heat Dissipation of 2,100W or 7,165BTU/hour.

- Under certain conditions, the National Electrical Code® (NEC) requires greater clearances. Use the clearances listed in NEC 2023, paragraph 110.26 and Canadian Electrical Code® CSA C22.1.
- The Sol-Ark 18K-2P-LV is a NEMA 3R - IP65 enclosure rated for outdoor installation, but it can also be installed indoors.

18K Installation QuickStart

Step 4. Mount inverter to surface with proper hardware.

- A. Use screws or anchors suitable to support inverter weight (135 lb)
 - Concrete or masonry: Minimum (4) M12x60mm expanding anchors
 - Wood frame: Minimum (5) 1/2" lag screws with flat washers, making sure to anchor into at least 2 framing members
 - Metal frame: Minimum (5) 1/4" self-tapping screws with flat washers
- B. Secure inverter to French Cleat (3) of the M4x12mm socket head screws
- C. Inverter should be in optimal upright position
- D. Remove the film cover from the LCD screen.

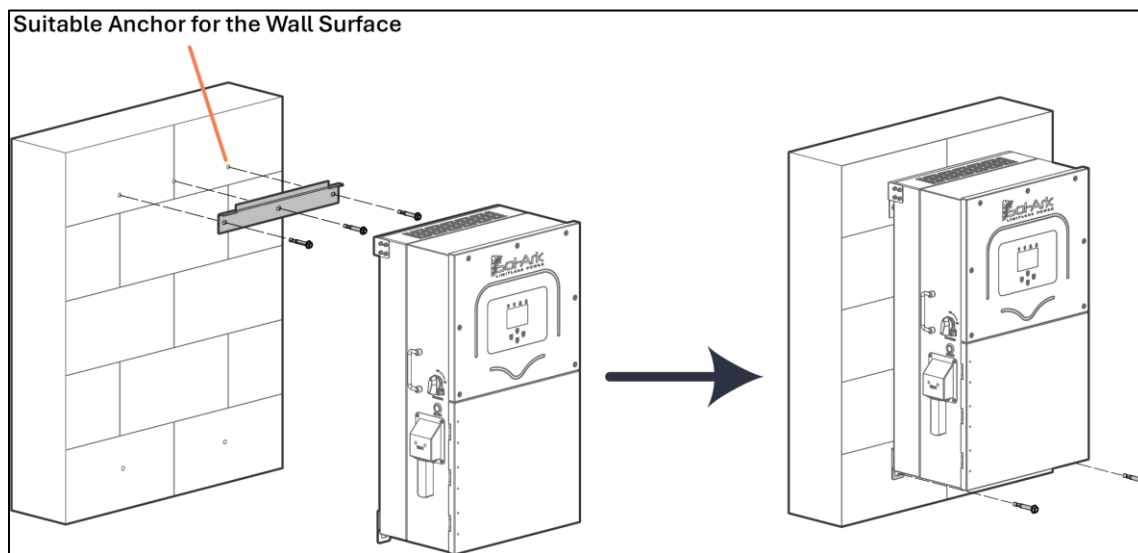

NOTE: Damage to the LCD screen due to direct sunlight is not covered by warranty.

- See [Mounting the Sol-Ark \(Step 4 Details\)](#) for additional information.

18K Installation QuickStart

Step 4b. Install the LCD Sunshade (outside installations only)

If the Sol-Ark is installed outside, attach the LCD Sunshade. This will help prevent screen damage from UV exposure.

- A. Peel off the plastic film from the inverter's display surface, if it's not already removed.
- B. Make sure the surface is clean and dry before installation.
- C. Attach the base plate:
 1. Peel the backing from the double-sided adhesive tape.
 2. Align the base plate with the display area. The adhesive is permanent, so confirm the alignment before applying pressure.
 3. Press firmly to secure the LCD Sunshade.
- D. Assemble the Sunshade flap:
 1. Insert the flap's hinge pins into the hinge slots on the base plate.
 2. Verify that the flap opens and closes smoothly.

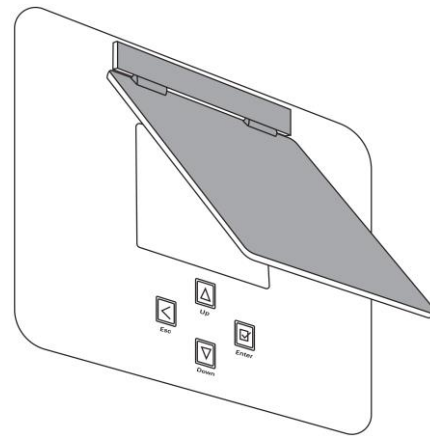

NOTE: Damage to the LCD Screen due to direct sunlight exposure will not be covered by warranty.

Need to purchase an LCD Sunshade?

LCD Sunshades were included with Sol-Ark inverters starting on May 4, 2026. If you have an outdoor installation and did not receive an LCD Sunshade, you can purchase one by going to the [Sol-Ark Online Store](#).

18K Installation QuickStart

Inverter Wiring

Step 5. Connect inputs and outputs.

Locate inputs in the user wiring area and connect all wire into inputs/outputs if applicable.

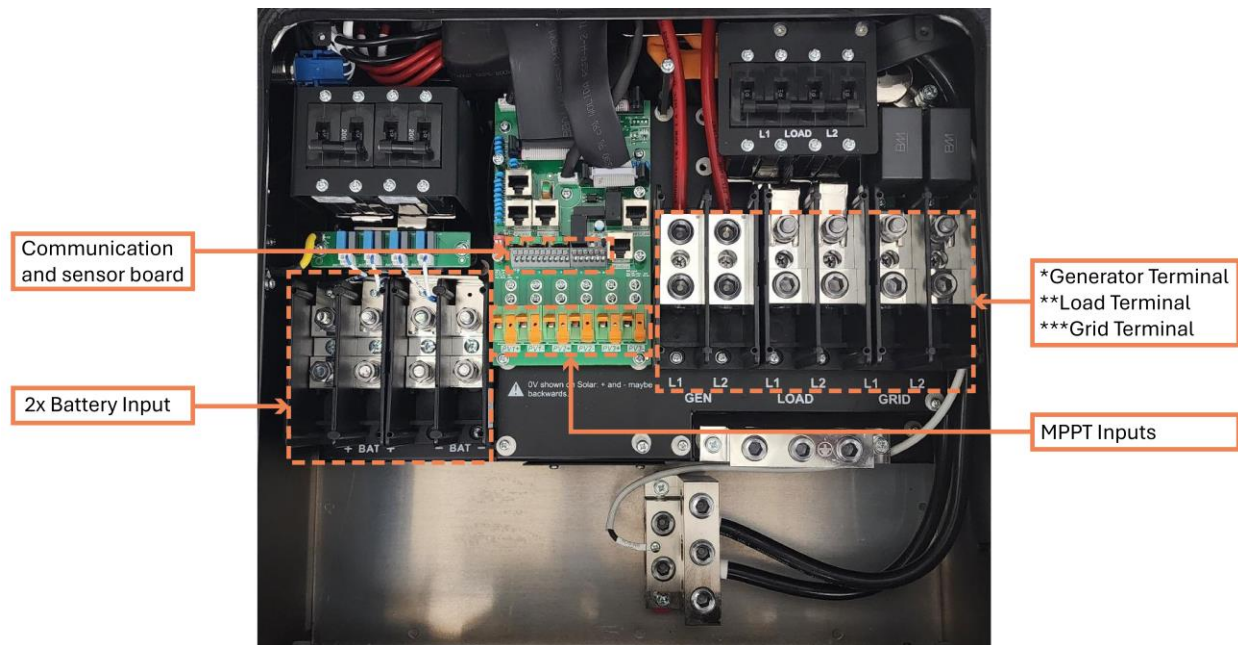

Notes

- **GEN** port can also be used for AC Coupling or Smart load output
- GRID port can also be used for a generator
- If your system came with **Filter Rings**, see the [18K Installation Manual](#) for instructions

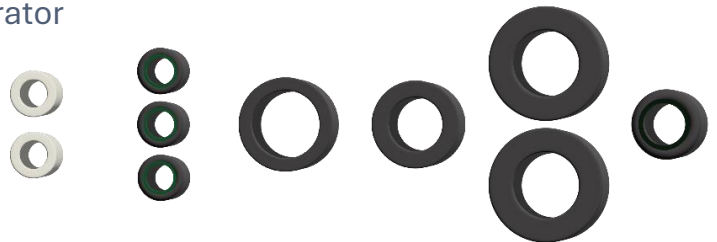

- See [Inverter General Description](#) for more information on inverter wiring.

18K Installation QuickStart

Step 6. Check wiring area.

In the inverter user wiring area, check these:

- Connections have correct torque
- Wire is sized appropriate to terminal rating and NEC requirements

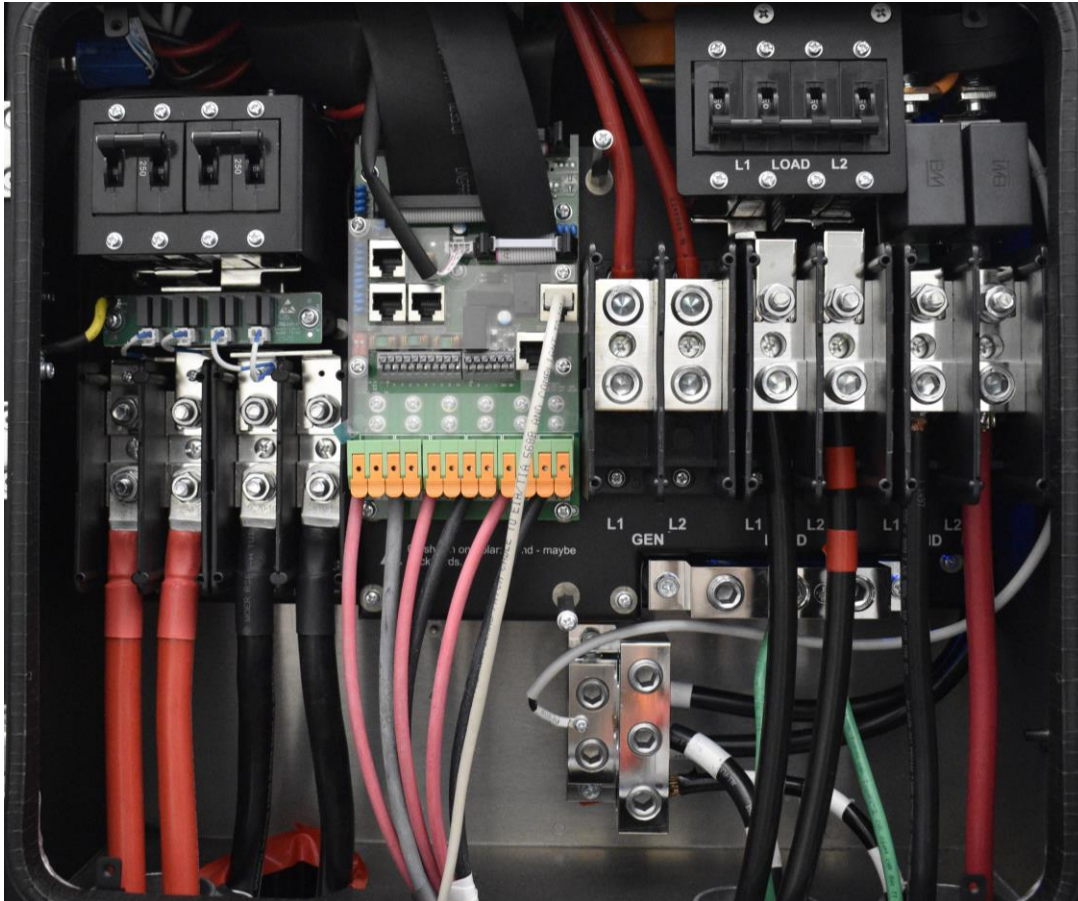

NOTES

- See the [18K-2P Installation Manual](#) for correct torque specifications and terminal wire size range (min-max).
- Do NOT have inverter, PV, batteries, or grid/gen AC disconnect closed while checking wires.

18K Installation QuickStart

Step 7. Integrate batteries with Inverter.

- A. Confirm battery wiring methodology: make sure battery inputs are being used for full 18kW output
- B. Check polarity for each battery connected to busbar
- C. For closed-loop operation, use a standard 8-pin Ethernet port, but refer to the battery manufacturer for pin-out requirements if needed
- D. Connect cable to BMS(s) port for proper closed loop communications
 - Use only BMS port

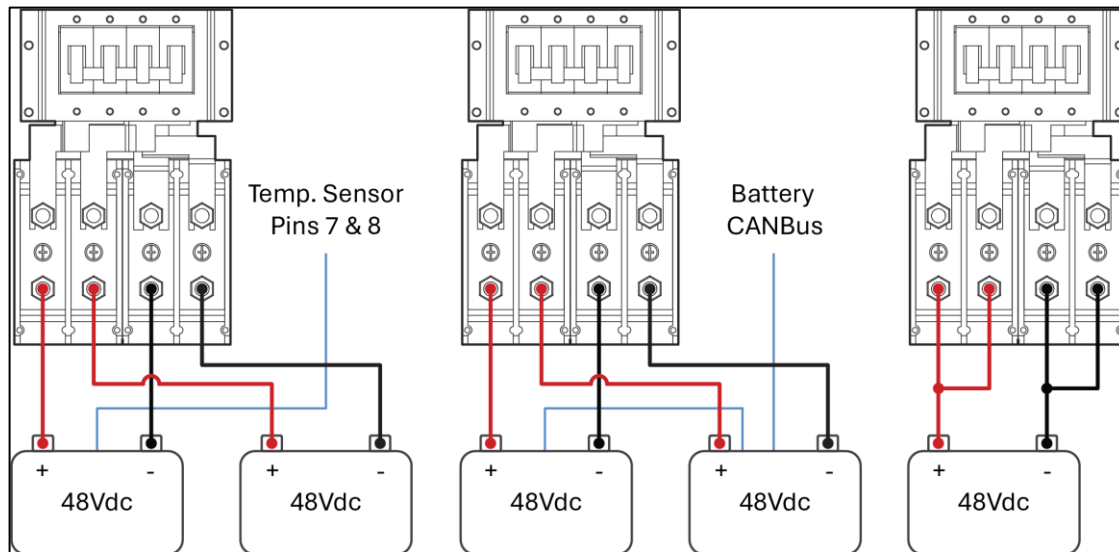

NOTE: See the battery manufacturer documentation for proper communication between multiple batteries.

- For more information on connecting batteries, see [Connection Requirements \(Step 7 Details\)](#)

Information on Parallel Systems

- For information on parallel systems, see [Considerations for Parallel Systems](#)

18K Installation QuickStart

Step 8. Check Polarity and Voltage.

A. Check wiring polarity and DC voltage on each input

- Use a multimeter to check (+) and (-) voltage to confirm correct polarity and operating voltage from the battery bank
- Ensure battery internal breaker or switch is closed
- See the battery manufacturer manual for proper battery startup sequence

B. Flip up or turn ON Sol-Ark battery breakers

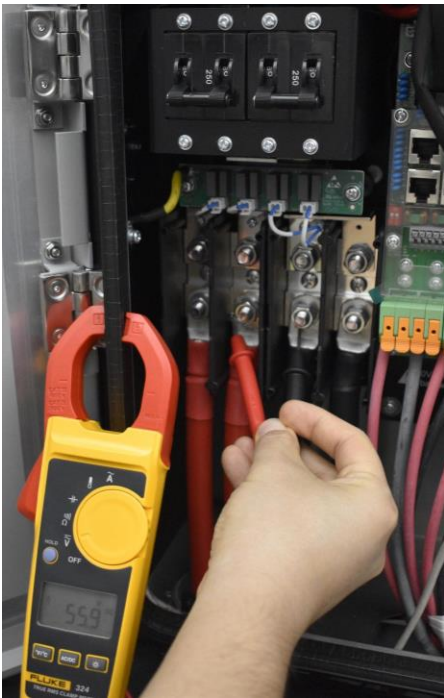

Parallel Systems Considerations

- All AC Inputs/Outputs (**GRID, LOAD, GEN**) and batteries must be paralleled across all inverters.
- PV Strings are **NOT** paralleled across inverters.

18K Installation QuickStart

Step 9. Connect Battery Cables

Connect battery communication cable(s) to the BMS input(s) on sensor board area.

- Using one input (**190A**)
- Using both inputs (**380A**)

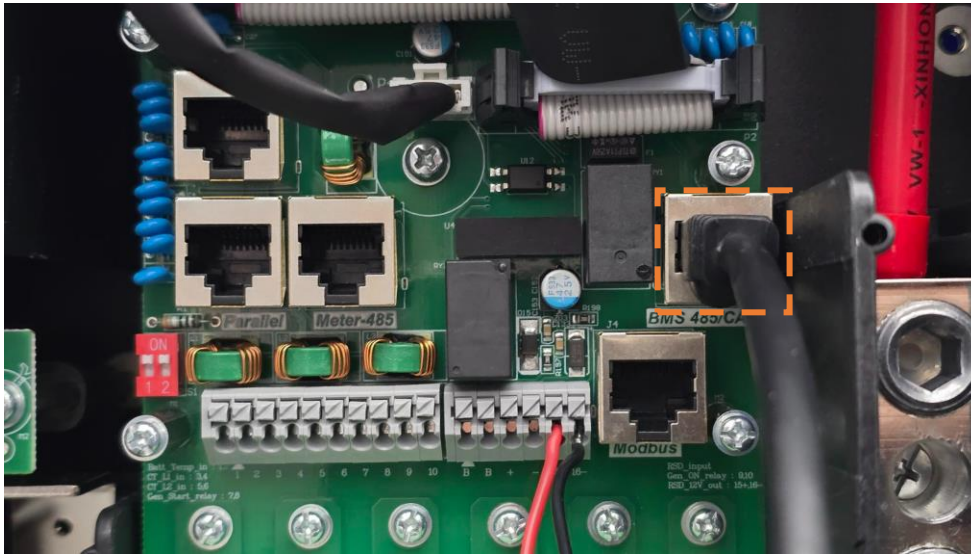

The BMS 485/CAN port is highlighted above.

- **For battery communication wiring:** See the battery manufacturer's guide to confirm methodology based on the battery module configuration.
- **For closed loop communication steps:** See the [Low Voltage 48V Residential Battery Integration Guide](#) on the Sol-Ark Knowledge Hub.

18K Installation QuickStart

Step 10. Turn inverter ON.

Press the inverter **ON** button and wait for the Normal LED to light up above the screen.

- If you're waiting more than 3 minutes, check battery voltage on terminals to make sure it's within operating voltage.



18K Installation QuickStart

Set Up Batteries

Step 11. Set up battery communications.

On the Inverter screen, go to **Settings > Battery Setup** to program battery communications.

- A. Check **BMS Lithium Batt** 01 (if applicable); note that the value will vary from 00-09 depending on the battery
- B. Check **Activate Battery** and **Use Batt %** or **Use Batt V Charged**
- C. Tap **OK**

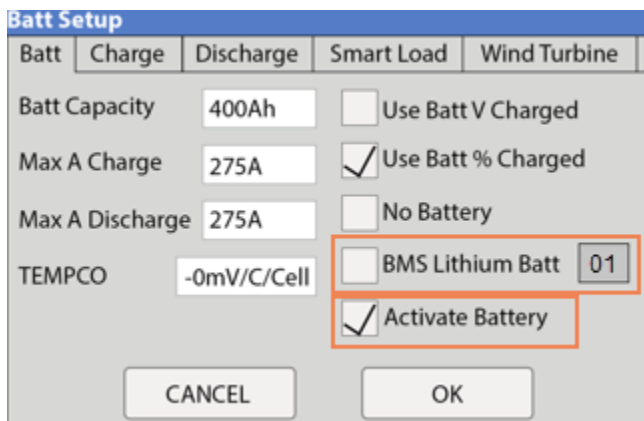

The screenshot shows the 'Batt Setup' screen with the following settings:

Batt	Charge	Discharge	Smart Load	Wind Turbine
Batt Capacity	400Ah		<input type="checkbox"/> Use Batt V Charged	
Max A Charge	275A		<input checked="" type="checkbox"/> Use Batt % Charged	
Max A Discharge	275A		<input type="checkbox"/> No Battery	
TEMPCO	-0mV/C/Cell		<input type="checkbox"/> BMS Lithium Batt 01	
			<input checked="" type="checkbox"/> Activate Battery	

Buttons: CANCEL, OK

- See your battery manufacturer to confirm that all battery settings are programmed appropriately per the battery specifications.
- **Li-Batt Info** shows information sent by the BMS such as battery voltage, charge/discharge current limits, temperature, etc. For more, see Step 12 on the next page.
- See [Battery Setup](#) to confirm that all battery settings are programmed appropriately according to the battery specifications.

18K Installation QuickStart

Step 12. Check battery communications.

On the Main screen, tap **Li-Batt Info** to confirm communications are established between the battery and inverter. **Li-Batt Info** will not appear on the screen if **BMS Lithium Batt** was not selected in step 11.

Check these values to make sure they are correct:

- Voltage
- SOC
- Temperature
- Charge/discharge current limit

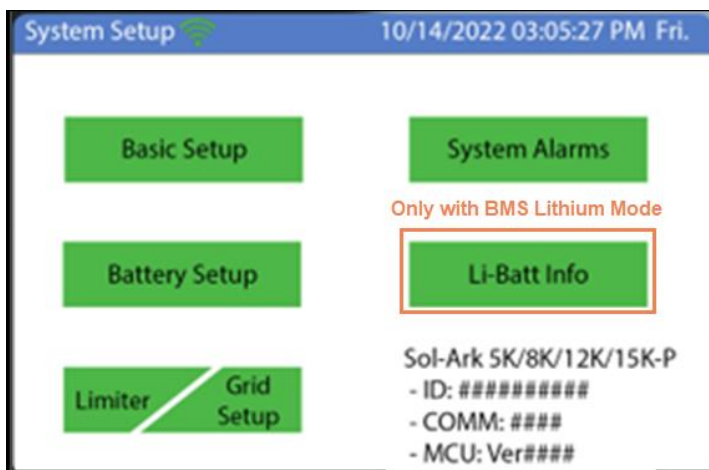

0.00 V	0.00 A	0.0 C	0%	0 Ah	
0.0V	0.0V	0A	0A	0x00	0x00
Only w/ BMS Lithium Mode					
1.	0.00V	0.00A	0.0C	0.0%	0.0V 0.0A 0 0 0
2.	0.00V	0.00A	0.0C	0.0%	0.0V 0.0A 0 0 0
3.	0.00V	0.00A	0.0C	0.0%	0.0V 0.0A 0 0 0
4.	0.00V	0.00A	0.0C	0.0%	0.0V 0.0A 0 0 0
5.	0.00V	0.00A	0.0C	0.0%	0.0V 0.0A 0 0 0
6.	0.00V	0.00A	0.0C	0.0%	0.0V 0.0A 0 0 0
7.	0.00V	0.00A	0.0C	0.0%	0.0V 0.0A 0 0 0
8.	0.00V	0.00A	0.0C	0.0%	0.0V 0.0A 0 0 0
9.	0.00V	0.00A	0.0C	0.0%	0.0V 0.0A 0 0 0
10.	0.00V	0.00A	0.0C	0.0%	0.0V 0.0A 0 0 0
11.	0.00V	0.00A	0.0C	0.0%	0.0V 0.0A 0 0 0
12.	0.00V	0.00A	0.0C	0.0%	0.0V 0.0A 0 0 0
13.	0.00V	0.00A	0.0C	0.0%	0.0V 0.0A 0 0 0

18K Installation QuickStart

Check Inverter Setup

Step 13. Check PV wiring polarity.

For each MPPT:

- A. Check for correct PV wiring polarity input
- B. Ensure expected open circuit voltage (Voc)
- C. Turn ON PV disconnect
- D. Confirm the DC LED is lit above screen



- Make sure the external DC disconnect for PV is turned on.
- If the power draw exceeds 100mA, have the transmitter energized by the inverter load output.
- If using a rapid shutdown device with transmitter energized by inverter load output, the circuit must be turned on to produce PV power.

18K Installation QuickStart

Step 13. Check PV wiring polarity (Continued)

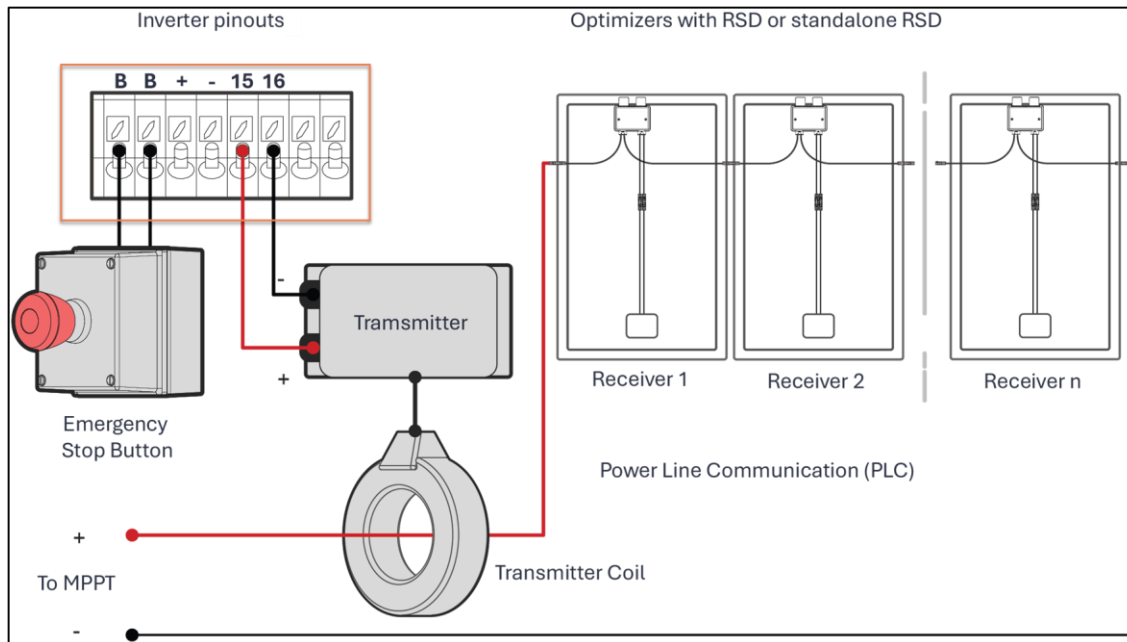

➤ See [Connecting PV Modules \(Step 13 Details\)](#) for more information.

18K Installation QuickStart

Step 14. Confirm Grid AC Voltage.

- A. Turn ON the Grid AC disconnect
- B. Check grid phasing and AC voltage levels. Confirm AC LED is lit above screen
- C. For off-grid setups with a generator, turn on the generator and follow the same steps on **GEN** or **GRID** input, depending on where it's wired.



Voltage Check with Multimeter

You can use a multimeter and phase tool to validate grid levels coming into terminals.

- **If off-grid configuration with a generator**, turn on generator and follow the same steps on GEN or GRID input (depending on where it's wired)
- **If off-grid configuration with no generator**, skip steps **15** and **16** starting on the next page
- See [Integrating a Generator](#) for more information.

18K Installation QuickStart

Step 15. Check Grid Parameters.

On the inverter screen, go to **Settings** > **Grid Param** and make sure that appropriate parameters are enabled.

The screenshot shows the 'Grid Param' settings screen. At the top, there are tabs for 'Grid Selection', 'Connect', 'IP', 'F(W)', 'V(W)/V(Q)', and 'P(Q)/P(F)'. The 'Grid Selection' tab is active, showing 'Grid Mode' as '3/3' and a dropdown menu set to 'UL1741SB'. Below this, 'Grid Frequency' has two options: '50Hz' (unchecked) and '60Hz' (checked). There are three phase options: 'Single Phase' (unchecked), '120/240V Split Phase' (checked), and '120/208V 3 Phase' (unchecked). On the right side, there are several input fields: 'Grid Reconnect Time' (300s), 'Power Factor' (1.000), 'Fixed Q' (0%), 'Q_Response' (10S), 'Output V' (120/240V), and 'Output V+' (+0V). At the bottom, there are 'CANCEL' and 'OK' buttons.

- See the [18K-2P Installation Manual](#) to make sure grid settings are correct and changed according to AHJ requirements and applicable levels.
- See [Check Grid Parameters \(Step 15 Details\)](#) for more information on grid settings.

18K Installation QuickStart

Step 16. Check Load AC voltage.

- A. Turn ON (200A) **LOAD** breaker and Measure AC voltage at **LOAD** terminals
- B. Turn ON the breaker or disconnect feeding **LOAD** panel.
- C. Check to make sure circuits on the load panel are energized



- Take phase-neutral and phase-phase measurements and make sure voltage on **LOAD** terminals are present and matches grid levels, if applicable.
- Make sure voltage on **LOAD** terminals are present and match grid levels, if applicable.

18K Installation QuickStart

Step 17. Test Island Mode.

- Turn the grid AC disconnect to OFF position. With batteries, Inverter should seamlessly switch to battery backup to load output.
- On main screen of inverter, click the battery icon to display the detailed voltage screen.

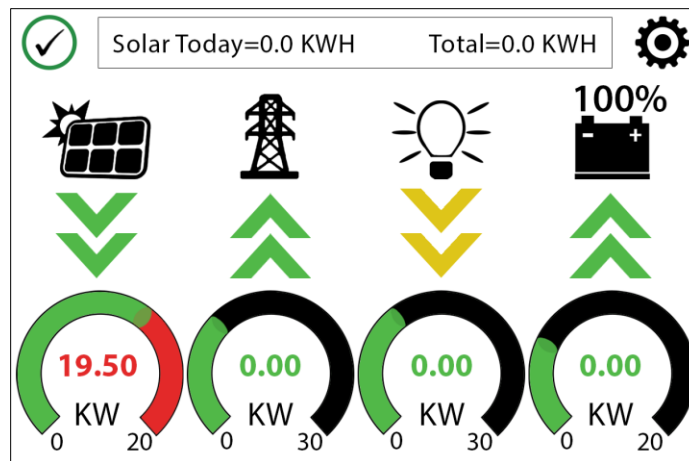

Solar	Grid	INV	UPS LD	Batt
0W	0W 0.0Hz	124W 60.0Hz	120W 120V	127W 35% 52.08V
M1: 0V 0.0A 0W	0V HM: 0W	120V 2.7A	60W 120V	L1: 1.4A L2: 1.0A 2.4A
M2: 0V 0.0A 0W	LD: 0W 0V	65W 120V	60W AC IN	23.0C TEMP
M3: 0V 0.0A 0W	HM: 0W LD: 0W	2.7A 59W	L1: 2W L2: 2W 60.0Hz	AC: 41.7C

- Under **INV** column, make sure L1 and L2 have correct voltage
- Under **Batt** column, make sure battery voltage is present

18K Installation QuickStart

Set Up WiFi

Step 18. Connect the Dongle.

Connect the dongle into the **DP-9** WiFi port on the left side of the inverter.



- A solid red LED indicates power to the device.

18K Installation QuickStart

Step 19. Create the plant.

After downloading the **MySolArk** app in Step 2, you can now create a plant by opening the app, scanning the QR code, and filling out required fields.

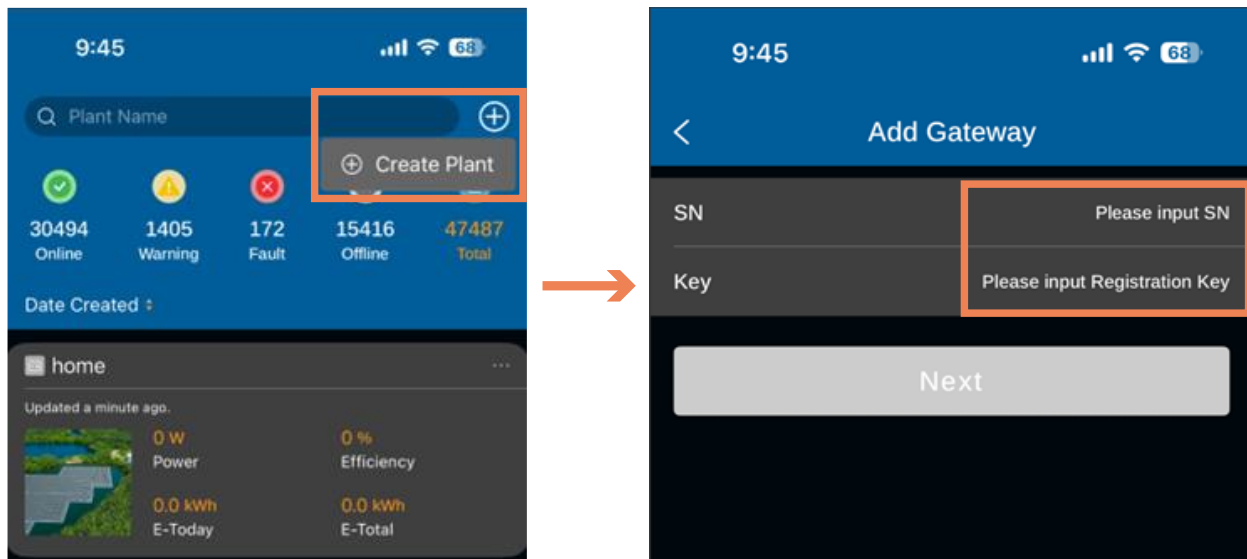

- Configure the WiFi network to the dongle via MSA. A green LED will light on the dongle when the network is connected.

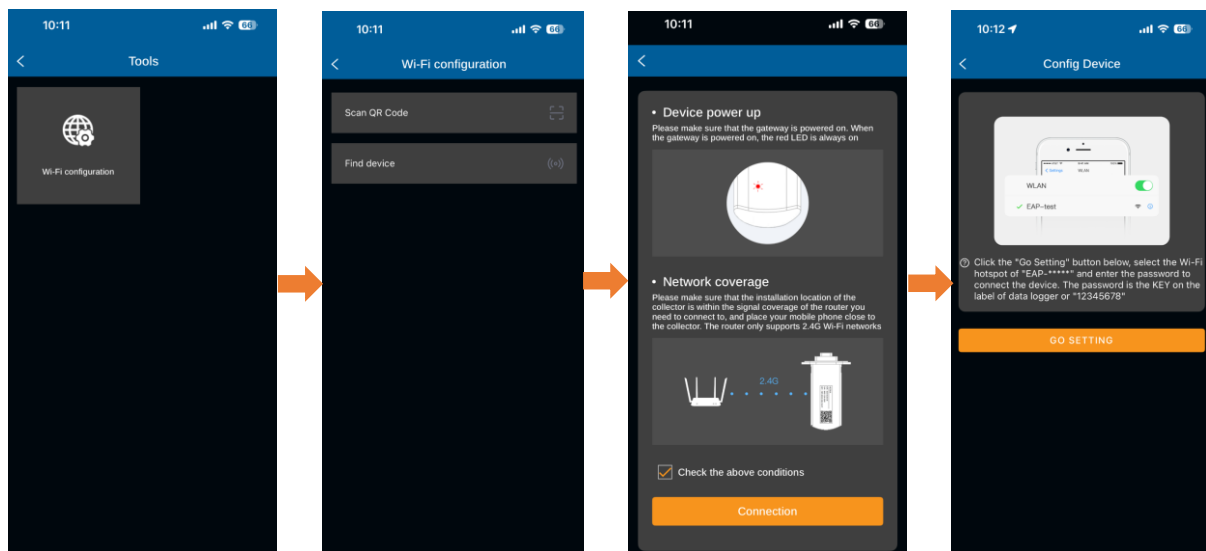

- For more information, see [Create a Plant on MySolArk \(Step 19 Details\)](#)

18K Installation QuickStart

Step 20. Check LED status of Dongle.

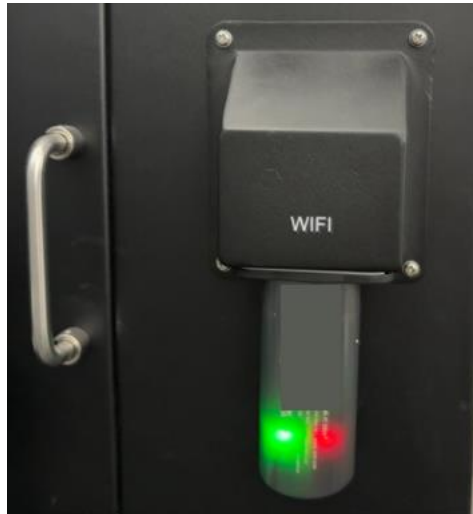

- If unsuccessful, try the steps in [Alternate Method for Connecting to WiFi using IP Address \(Step 18 Details\)](#).

18K Installation QuickStart

Step 21. Check network stability.

In **MySolArk**, review data to ensure the network is stable and power flow data is showing correctly.

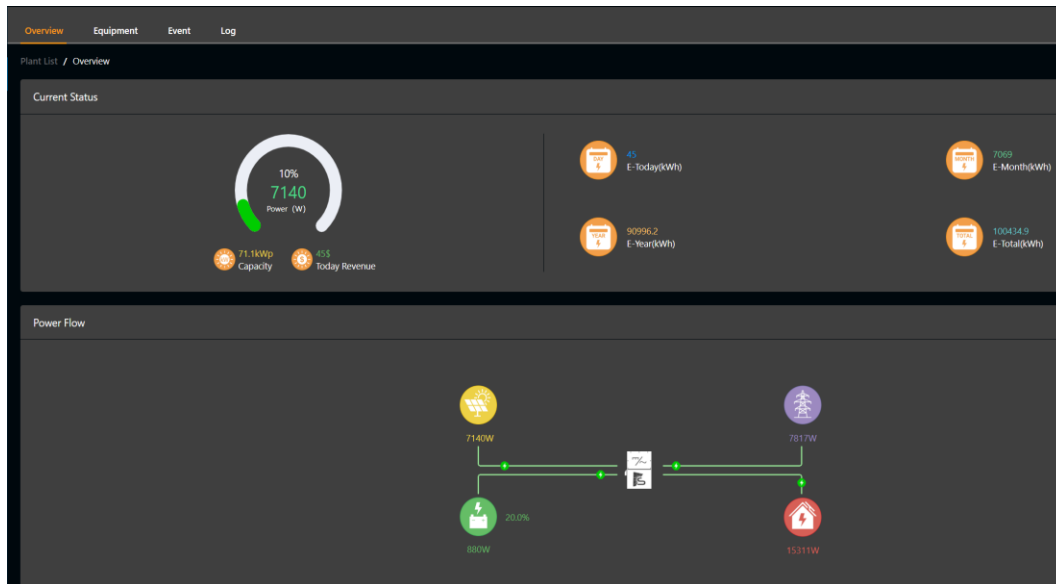

NOTE: MSA data is not real-time, as a data point will populate every 5 minutes. It's recommended to compare the Sol-Ark power flow on the GUI screen against what MSA reports for the created plant.

18K Installation QuickStart

Step 22. Check system performance.

If necessary, go through the rest of the settings to program the desired system performance.

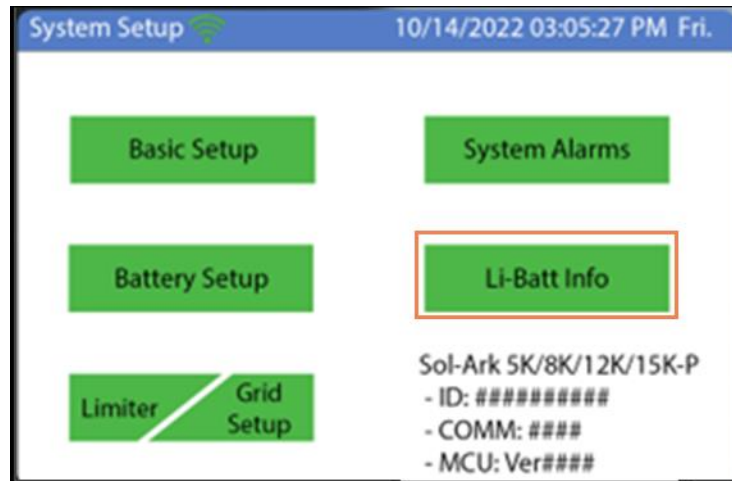

- For information about the different system work modes, go to [System Work Modes \(Step 22 Details\)](#)
- For information about TOU settings, go to [Time of Use \(TOU\)](#)
- For information about peak shaving, go to [Advanced Setting – Grid Peak Shaving](#)

18K Installation QuickStart

Software Updates

- A. On the inverter screen, find the current software version by clicking the gear icon and looking at the bottom right of the screen.

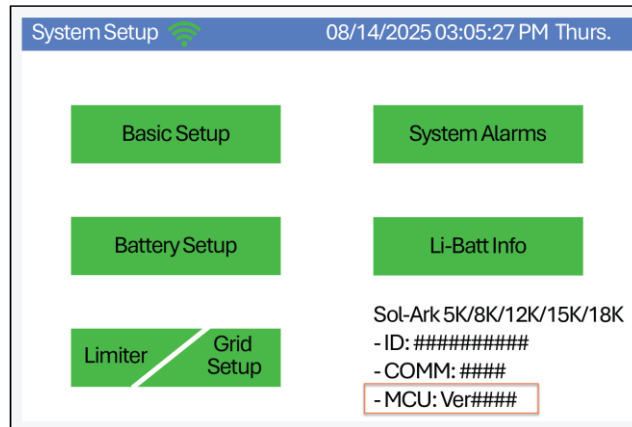

- B. Find the latest software version for your inverter in either of these ways:
- On **MySolArk**, go to the **Equipment** tab.
 - On the Sol-Ark website, go to the [Software Updates](#) page.
- C. If the software version is different than what the website shows, scroll down and submit an **Update Request Form**.
- D. About 30-40 minutes after the update was scheduled, repeat Step A to confirm the latest software version.

18K Installation QuickStart

Considerations for Parallel Systems

For multiple inverters, follow the steps for each unit in the system with these considerations:

- All AC Inputs/Outputs (**GRID, LOAD, GEN**) should have paralleled connection across all inverters
- **Step 8** – PV Strings are NOT paralleled across inverters
- **Step 9** – Batteries MUST be paralleled across inverters
- In **Settings**, specify the Parallel Settings on the **Basic Setup** screen.
 - For all units, select the **Parallel** check box
 - On the Master unit, select **Master** and set Modbus serial number to **01**
 - On all Slave units, select **Slave** and set the Modbus serial number counting up from “02, 03, 04...” etc.
 - Make all Settings changes at the Master inverter, except for the **Parallel** tab

The screenshot shows the 'Basic Setup' screen with the following settings:

- Parallel** checkbox:
- Master/Slave** radio buttons: Master, Slave
- Modbus SN**: 00
- Phase** radio buttons: Phase A, Phase B, Phase C
- Meter > Grid** checkbox:
- Meter > Load** checkbox:
- Meter Select** dropdowns: No Meter
- Buttons**: CANCEL, OK

MORE INFORMATION

More Information

Mounting the Sol-Ark (Step 4 Details)

Mount the inverter in the optimal orientation as shown.

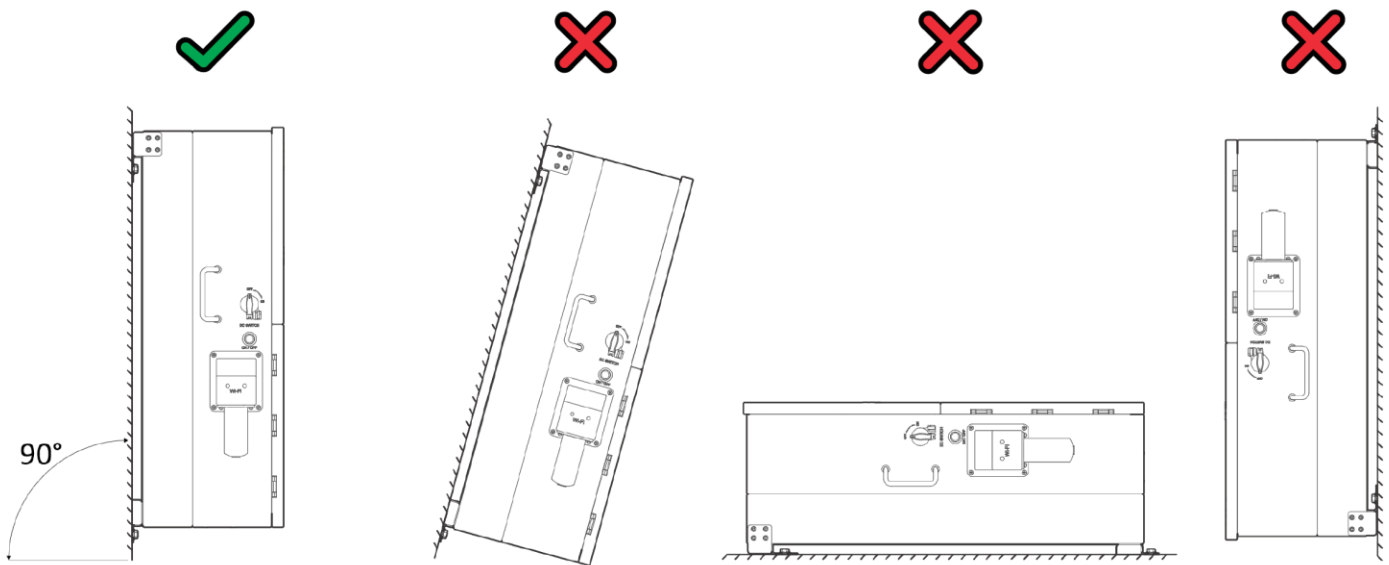

➤ Return to [Step 4. Mount inverter to surface with proper hardware.](#)

More Information

Inverter General Description (Step 5 Details)

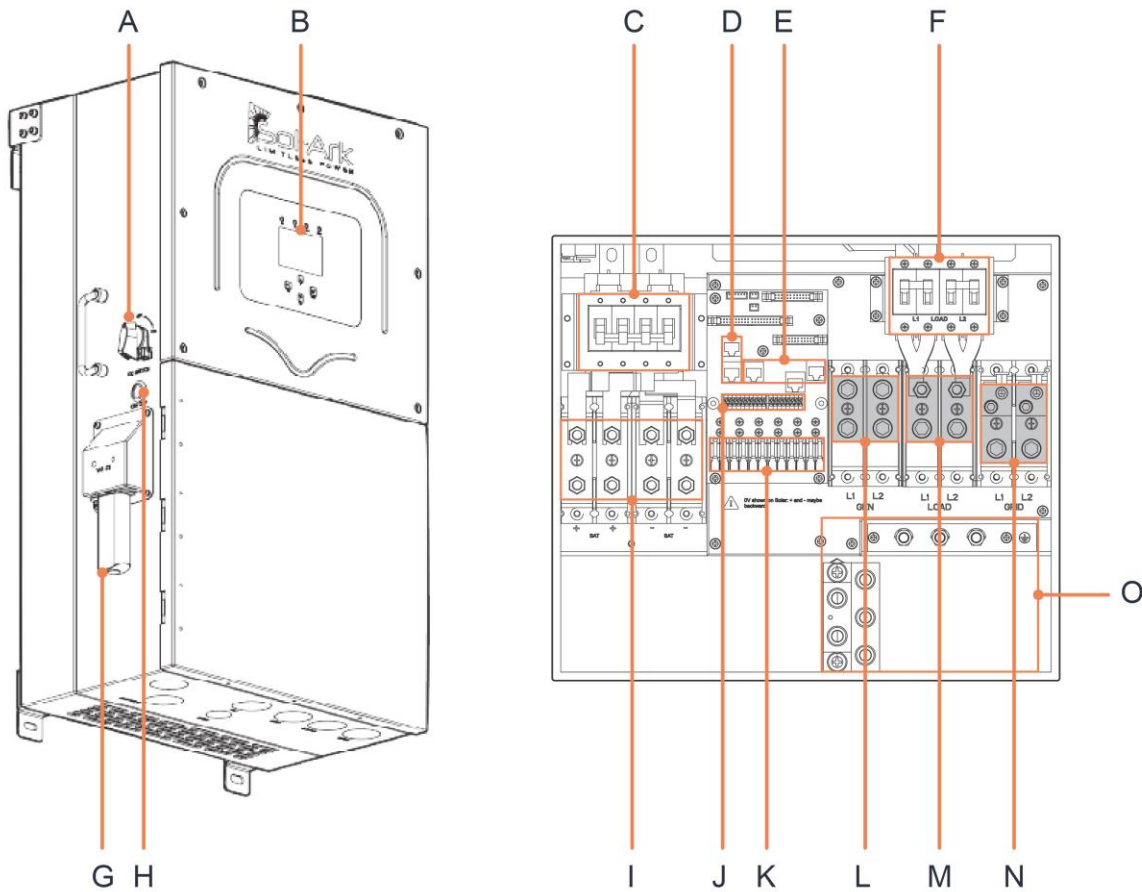

Component	Name
A	PV DC disconnect
B	LCD touch screen
C	2x (250A) battery breakers ¹
D	Parallel RJ45 ports
E	BMS RJ45 ports (RS485 / CAN)
F	(200A) LOAD breaker
G	Wi-Fi / Ethernet dongle
H	ON / OFF Button

Component	Name
I	Battery terminals
J	Input pinouts for sensors and accessories
K	3x MPPT inputs
L	(150A) GEN terminal
M	(200A) LOAD terminal
N	(200A) GRID terminal
O	GROUND / NEUTRAL Busbars

➤ Return to [Step 5. Connect inputs and outputs.](#)

More Information

External CT Sensors (Step 5 Details Continued)

CONN Board CT Sensor Pins

A. Determine if applicable to installation

- Use if system has non-backed loads upstream
- Use if **Peak Shaving** will be enabled
- Use for multi-inverter installation
- Not necessary for whole system backup
- Not necessary for off-grid unless peak shaving a backup generator into grid port

Limit Sensor Overview

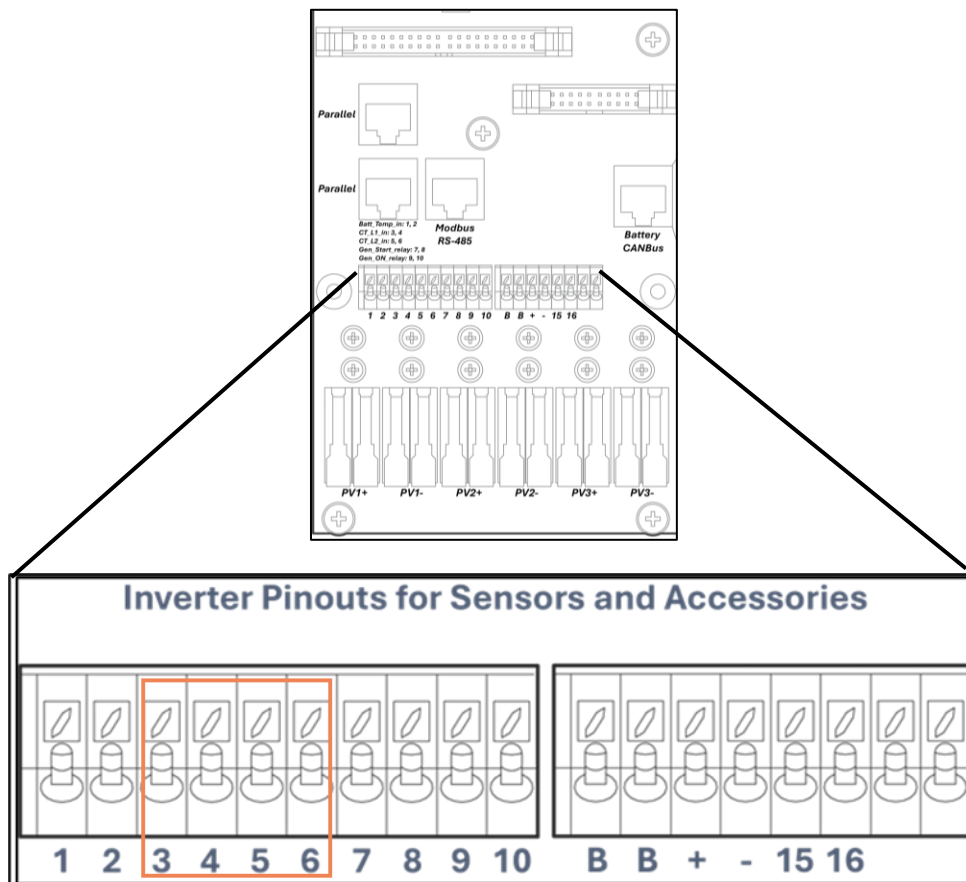

➤ See the [18K Installation Manual](#) for more on the CT sensors board.

More Information

External CT Sensors (Step 5 Details Continued)

CONN Board

- A. Confirm CTs are sized appropriately for amperage of service used
- B. Determine the distance from CT placement to CONN sensor board input in case an extension is needed
- C. Install CTs between meter and line side tap
- D. If using a generator, install CTs between the generator and Sol-Ark inverter AC input
- E. Verify correct A and B phase from the AC power source before clamping the CTs
- F. Make sure CTs are oriented correctly:
 - If grid voltage is 240V, the CTs point toward the meter
 - If grid voltage is 208V, the CTs point away from the meter
- G. Check HM values on detailed volt screen to ensure correct power readings

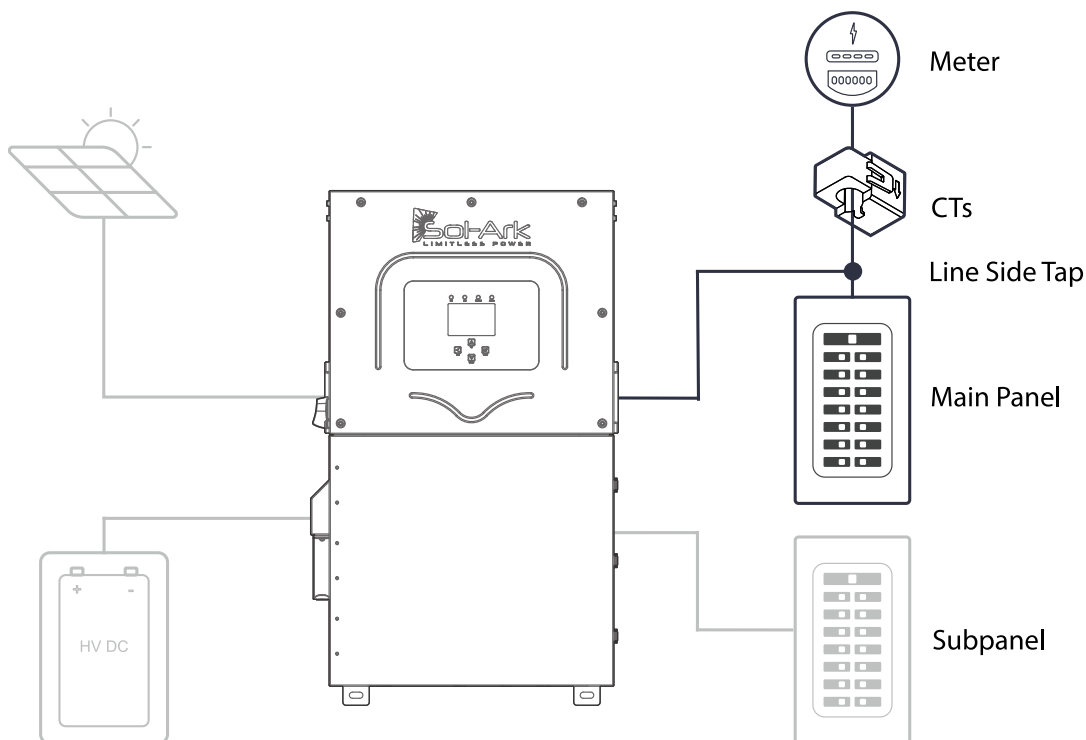

➤ See the [18K Installation Manual](#) for more information on external CTs.

More Information

External CT Sensors (Step 5 Details Continued)

Wiring the CT Sensor

Make sure to use correct pin out for external CT wiring. Confirm on the detailed voltage screen that power flow is correct by reviewing the HM values for each phase. Positive (+) value are power being imported, and negative (-) indicates power being exported.

- A. Connect CT1 of line L1 to pins **3** (white) & **4** (black) of the pin board.
- B. Connect CT2 of line L2 to pins **5** (white) & **6** (black) of the pin board.
- C. Keep the wires twisted (white-black) throughout the connection.
- D. If the wires need to be extended, use CAT 6 (shielded) cable to make an extension.

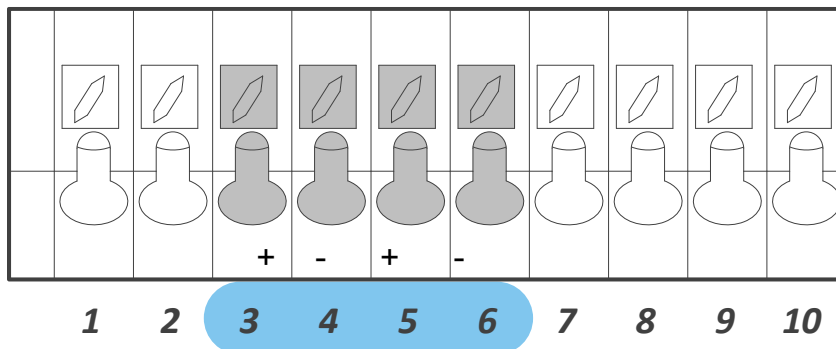

More Information

External CT Sensors -- (Step 5 Details Continued)

Generator Dry Contact

If applicable, use pins **7** and **8** for generator auto-start:

- Dry contact relay that is Normally Open (NO)
- Closes based on the Grid/Gen start battery SOC/V setpoint being triggered in battery settings
- Optional battery setting Gen Force is recommended to test the generator's 2-wire start functionality
- Do NOT induce power through these pins or non-warranty damage may occur

Emergency Stop

A. Rapid shutdown compliance requires using pins **B+** and **B-** to initiate emergency stop of the system when activated.

- Open circuit that closes when push button activated
- Causes loss of voltage on LOAD output, loss of 12Vdc on pins **15** and **16**, and PV voltage

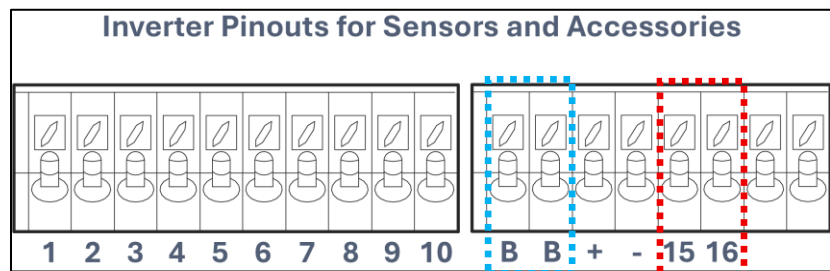

B. Optional 12Vdc supply energize rapid shutdown transmitters using pins **15** and **16**

- 100mA limit for sensor pins so must verify specifications of transmitter current
- If >100mA is required, then energize transmitter of a circuit on LOAD output (may require 120Vac to 12Vdc power supply)

More Information

Connection Requirements (Step 7 Details)

AC/DC Connection Requirements

All wire runs should be sized to be at or below a 2.5% voltage drop at full load. Equipment wire sizing must comply with the NEC or local electrical code.

The table below shows the ampacity ratings of the various connection points in the field wiring area of the inverter. Copper conductor is recommended.

Port	Terminal Rating	Terminal Wire Size Range (min-max)
GRID	255A AC	1/0 – 4/0 AWG
LOAD	255A AC	1/0 – 4/0 AWG
GEN	255A AC	2 – 4/0 AWG
MPPT	44A DC	12 – 10 AWG
Battery Port A	255A DC	2/0 – 4/0 AWG
Battery Port B	255A DC	2/0 – 4/0 AWG

Sensors and Communications Requirements

Component	Wire Size Range	Max Distance
CT Sensor	18-23 AWG	0' – 10' [3 m]: 23 AWG included 10' – 150' [50 m]: CAT6 extendable
Communications	24 – 23 AWG	0' – 100' [30 m]: 24 AWG 100' – 400' [120 m]: 23 AWG
RJ45 Parallel Communication	CAT 5E or better	0' – 7' [2.1 m]: Included 7' – 20' [6m]: Extendable

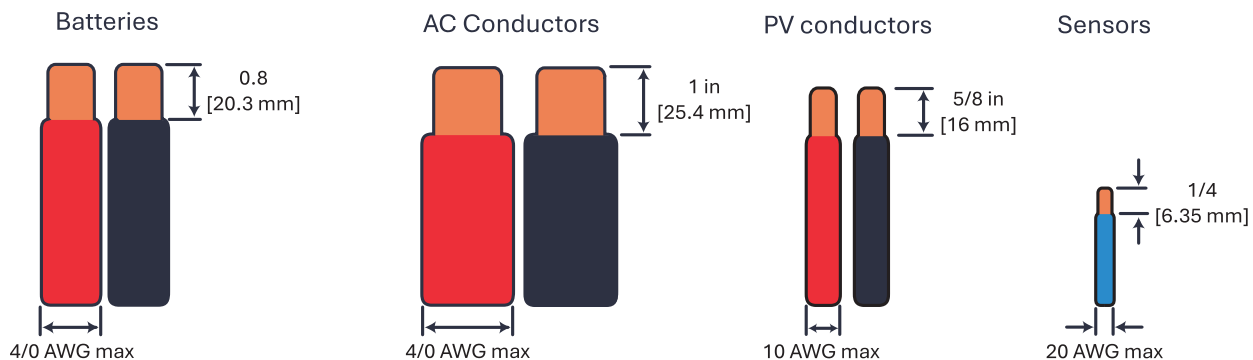

More Information

Connection Requirements (Step 7 Details Continued)

Fastener Torque Table

NOTE: Do not use impact drivers to tighten any fasteners on the inverter.

Terminal / Breaker	Torque [ft-lb]	Torque [Nm]
LOAD	18.75 ft-lb	25.5 Nm
GRID	18.75 ft-lb	25.5 Nm
GEN	18.75 ft-lb	25.5 Nm
Neutral / Ground (Busbar)	18.75 ft-lb	25.5 Nm
Cover Screws	15.5 in-lb	1.75 Nm
Battery Terminals	Push-in Cage Clamp	Push-in Cage Clamp

➤ Return to [Step 7. Integrate batteries with Inverter.](#)

More Information

Battery Communications (Step 10 Details)

DANGER: Reverse Polarity



DO NOT reverse the battery input wires: the system will be damaged, and the warranty voided.

Multi-Terminal Installation

You must use both positive and negative terminals as shown in the illustration.

If you're using two sets of conductors to connect the batteries to the inverter, it's recommended to use a busbar or another suitable combiner for balanced battery charge and discharge. This configuration also ensures that you can charge and discharge at the maximum rate.

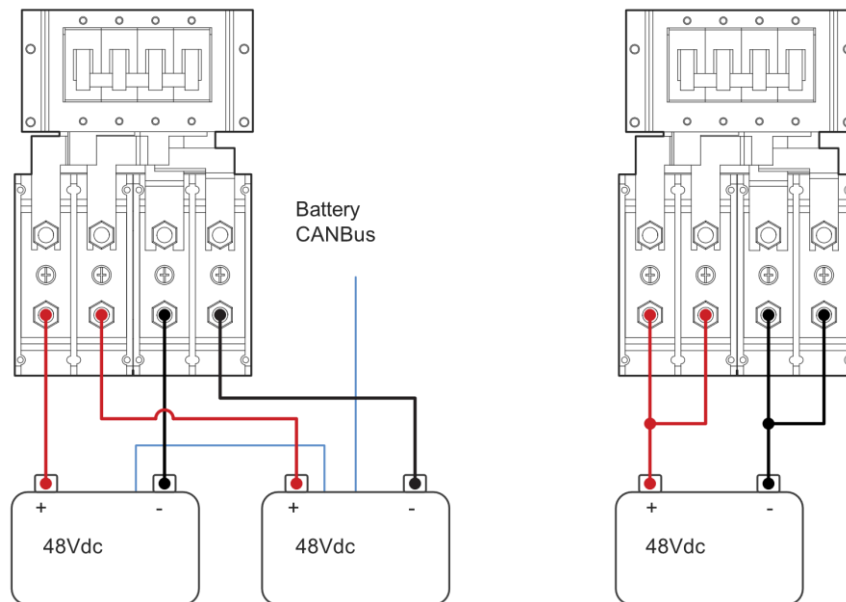

NOTE: It's possible to connect more batteries than the number shown.

More Information

Battery Communications (Step 10 Details Continued)

The 18K inverter can establish closed-loop battery communication through one or two separate RJ-45 ports labeled **Battery/CANBus**. Communication with battery BMS will depend on the wiring of the battery bank and the wiring to the Sol-Ark inverter.

➤ For more information, see [Sol-Ark Low Voltage Battery Integration Guide](#)

Power-ON Sequence

- A. Turn ON the Sol-Ark battery breaker and external battery switch (if applicable)
- B. Press the inverter power button and wait for the normal LED to light
- C. Turn ON the PV Disconnect and wait for the DC LED to light
- D. Turn ON the external grid AC Disconnect or breaker feeding GRID input and wait for the AC LED to light
- E. Turn ON the external load AC Disconnect or breaker feeding backup load panel

Power-OFF Sequence

- A. Turn OFF the external load AC Disconnect or breaker feeding backup load panel
- B. Turn OFF the external grid AC Disconnect or breaker feeding GRID input
- C. Turn OFF the PV Disconnect
- D. Press the inverter power button and wait for the normal LED to turn OFF
- E. Turn OFF the Sol-Ark Battery Breaker and external battery switch (if applicable)

Return to [Step 10. Turn inverter ON.](#)

More Information

Battery Setup screens (Step 11 Details)]

NOTE: Default values on your model may be different than those pictured.

The image displays four screenshots of the 'Batt Setup' screen, organized into two rows and two columns. Each screen has tabs for 'Batt', 'Charge', 'Discharge', and 'Smart Load'.
Top-left screenshot: Shows 'Batt Capacity' (400Ah), 'Max A Charge' (275A), 'Max A Discharge' (275A), and 'TEMPCO' (-0mV/C/Cell). It includes checkboxes for 'Use Batt V Charged', 'Use Batt % Charged', 'No Battery', 'BMS Lithium Batt', and 'Activate Battery'.
Top-right screenshot: Shows 'StartV' (49.0V), 'Start%' (30%), 'A' (40A), 'Float V' (55.7V), 'Absorbion V' (56.0V), and 'Equalization V' (56.0V). It includes checkboxes for 'Gen Charge' and 'Grid Charge', and a 'Generator Exercise Cycle Day & Time' field set to 'Mon 08 :00 20min'.
Bottom-left screenshot: Shows 'Shutdown' (46.0V, 20%), 'Low Batt' (47.5V, 35%), 'Restart' (52.0V, 50%), and 'Batt Empty V' (47.0V). It includes fields for 'Batt Resistance' (8mOhms), 'Batt Charge Efficiency' (99.0%), and a checkbox for 'BMS_Err_Stop'.
Bottom-right screenshot: Shows checkboxes for 'Use gen input as load output', 'On Grid always on', and 'For AC Coupled Input to Gen'. It includes a 'High Frz' field (62.00Hz), 'Smart Load OFF Batt' (51.0V, 80%), 'Smart Load ON Batt' (54.0V, 90%), and a 'Solar Power(W)' field (500W). A checkbox for 'AC couple on load side' is also present.

Batt

Batt Capacity: Specifies the capacity of the battery bank in Amp Hour (Ah).

- Batteries in series → Voltage adds up (V).
- Batteries in parallel → Capacity adds up (Ah).

Max A Charge: Sets the maximum charge current (A) rate to the batteries when charged from solar power → 350A max allowed if using both battery terminals.

Max A Discharge: Sets the maximum discharge current (A) rate from the batteries → 350A max allowed if using both battery terminals.

For Off-Grid systems, the battery bank will discharge 150% of this value for a 10-second surge before the inverter faults to prevent battery damage.

More Information

Battery Setup (Step 11 Details Continued)

TEMPCO: Temperature coefficient used in conjunction with the battery temperature sensor to adjust optimal voltages for lead-acid batteries.

NOTE: Lithium batteries do not require a TEMPCO setting (-0 mV/C/Cell).

Use Batt V Charged: Displays battery charge in terms of voltage.

Use Batt % Charged: Displays battery charge in terms of %. The inverter uses algorithms measuring power in and out to estimate a true value for state-of-charge %. It compensates for aging batteries.

No Battery: This option MUST be selected if there is no battery. A power cycle sequence is REQUIRED when selecting this option.

BMS Lithium Batt: Allows closed-loop communication with the tested batteries included in Sol-Ark's [Low Voltage Battery Integration Guide](https://sol-ark.com/solar-installer-corps/solar-battery-partners/). See <https://sol-ark.com/solar-installer-corps/solar-battery-partners/> for complete list of compatible batteries.

Activate Battery: This option MUST be selected if the system has batteries, especially Lithium batteries.

Charge

Float V: Lower steady voltage at which the battery is maintained after being fully charged. Set according to manufacturer specs.

Absorption V: Constant voltage used to charge the battery.

- Absorption will stop at 98% of the capacity of the battery bank and then drop to the Float setpoint.
- Example: A 400Ah battery will stop charge reaching 392Ah.

Equalization V: Voltage that the system uses to generate a calculated overcharge, utilizing a higher voltage or equal to the absorption to remove the generation of sulfates in batteries. Used to balance internal cells.

NOTE: Most Lithium batteries do not need to equalize.

More Information

Battery Setup (Step 11 Details Continued)

Days: The period between equalization cycles.

Hours: The period taken to equalize batteries.

NOTE: If **Hours** is set to **0** hours, the system will not equalize batteries.

Gen Charge: Uses the **GEN** AC source to charge the battery bank.

- **Start V:** Voltage at which the system will auto-start and allow a generator or AC source to charge the battery.
- **Start %:** SOC at which the system will auto-start and allow a generator or AC source to charge the battery.
- **A:** Maximum rate of charge to the batteries (per terminal) from the generator or AC source (DC Amps). Set the value according to the generator size.

Grid Charge: There are two scenarios when you might use this option:

- **Grid connected to GRID input:** The inverter will limit the charge rate to the set value in **A** and the battery will charge to 100% SOC.
- **Generator connected to GRID input:** It will be necessary to select **GEN connect to Grid input**. The system will use conditions **Start V**, **Start%** and **A** to charge the battery and stop charging at 95% SOC. The upper limit is adjustable upper if Time of Use is enabled.

Gen Exercise Cycle (Day & Time): Set a weekly generator exercise schedule. (Day of the week/time/duration length).

Gen Force: Test function for generator auto-start. Enable and press OK to close normally open relay (pins **7**, **8**) and force the generator on. Disable and press **OK** to disengage. The generator will not provide power during this test if grid power is available.

NOTE: The Gen must be in automatic mode if applicable and must have a two-wire start (dry-contact, normally open) connected to the Sol-Ark. To disable the Gen exercise, adjust the time duration to **0 min**.

More Information

Battery Setup (Step 11 Details Continued)

Discharge

Shutdown: Battery voltage or % at which the inverter will shut down to protect the battery from an over discharge situation (battery symbol on the home screen will turn red).

Low Batt: Low battery voltage or % (battery symbol on the home screen will turn yellow). Stopping point for TOU.

Restart: Battery voltage or % at which AC output will resume after previously reaching shutdown.

Batt Resistance: Internal resistance of mOhms from the battery bank. Used in % SOC batt calculations.

Batt Charge Efficiency: Value provided by battery manufacturer. Used in % SOC batt calculations.

Batt Empty V: Sets the empty voltage and associates this voltage to 0% SOC. This value determines the lowest % SOC limit.

BMS_Err_Stop: Enables system stop when there is loss of battery communications.

IMPORTANT: Continuous **GEN** input/output of **120A**. DO NOT EXCEED.

More Information

Battery Setup (Step 11 Details Continued)

Smart Load

- A. This mode uses the **GEN** input as a load output that delivers power when the battery exceeds a user programmable threshold or when the Sol-Ark is connected to the grid.
- B. When **Use gen input as load output** is enabled, the **GEN** input turns into an output to power high-power loads such as a water heater, irrigation pump, AC unit, pool pump, or any other load.
- C. When **On Grid always on** is enabled, the **GEN** terminal will always output power as long as the grid is connected, regardless of battery charge.
 - **Smart Load OFF Batt:** Battery voltage or % at which the **GEN** terminal will stop putting out power.
 - **Smart Load ON Batt:** Battery voltage or % at which the **GEN** terminal will start putting out power.
 - **Solar Power (W):** Amount of PV production needed before **GEN** terminal starts putting out power.

More Information

Battery Setup (Step 11 Details Continued)

AC Coupling Settings - (for AC Coupled Input)

- A. Grid-tied systems with AC coupled solar arrays must have the **Grid Sell** check box enabled. Be sure you are allowed to sell back to the grid.
- B. To use the **GEN** terminal as an AC coupling input for micro inverters or string inverters, enable the check box **For AC Coupled Input to Gen.**
- C. In off-grid systems, the Sol-Ark will use frequency shifting to control the AC coupled solution based on the battery SOC. The meaning of **Smart Load OFF Batt** and **Smart Load ON Batt** will change in this mode.
 - **Smart Load OFF Batt:** The % SOC at which the AC coupled inverters turn OFF.
90% recommended.
 - **Smart Load ON Batt:** The % SOC at which the AC coupled inverters turn ON.
80% recommended.

➤ Return to [Step 11. Set up battery communications.](#)

More Information

Connecting PV Modules (Step 13 Details)

NOTE: The Sol-Ark 18K-2P-LV has 3 independent MPPTs that support up to 2 PV strings each. MPPTs can handle a maximum V_{OC} of 500V and an ISC of 54A but will self-limit and operate at 36A max.

- A. Max Usable PV Power = 28.8 kW | Max input power per MPPT = 9.6 kW | Max recommended input voltage per MPPT = 425 V_{OC} | Max input current per MPPT = 36A (self-limiting).
- B. ⚠ Design for an input current of 36A per MPPT. The inverter will self-limit beyond 36A. If ISC exceeds 54A, damage will occur.
- C. ⚠ PV Source Circuit max voltage of 500 V_{DC} ; damage can occur with PV strings whose open-circuit voltage exceeds 500 V_{DC}

NOTE: Strings in parallel on the same MPPT must have the same designed open-circuit voltage (V_{OC}), otherwise, the system will be limited to the lowest string voltage.

- PV1 A/B must have the same V_{OC}
- If the solar panels are oriented in different directions and connected in the same MPPT, there will be a loss in PV efficiency

NOTE: According to NEC Art 690.43, exposed non-current-carrying metal parts of PV module frames, electrical equipment, and conductor enclosures of PV systems shall be connected to an equipment grounding conductor. All grounding conductors and grounding electrodes should be installed according to NEC Art 690.47 or as required by the AHJ.

- D. For ground-mounted arrays, Sol-Ark recommends installing an auxiliary grounding electrode placed near the array to ensure optimal earth-to-ground resistance of the grounding system. This auxiliary electrode would need to follow the requirements of NEC Art 250.54.

More Information

Connecting PV Modules (Step 13 Details Continued)

A. Connect the solar panel strings using either of the following configurations:

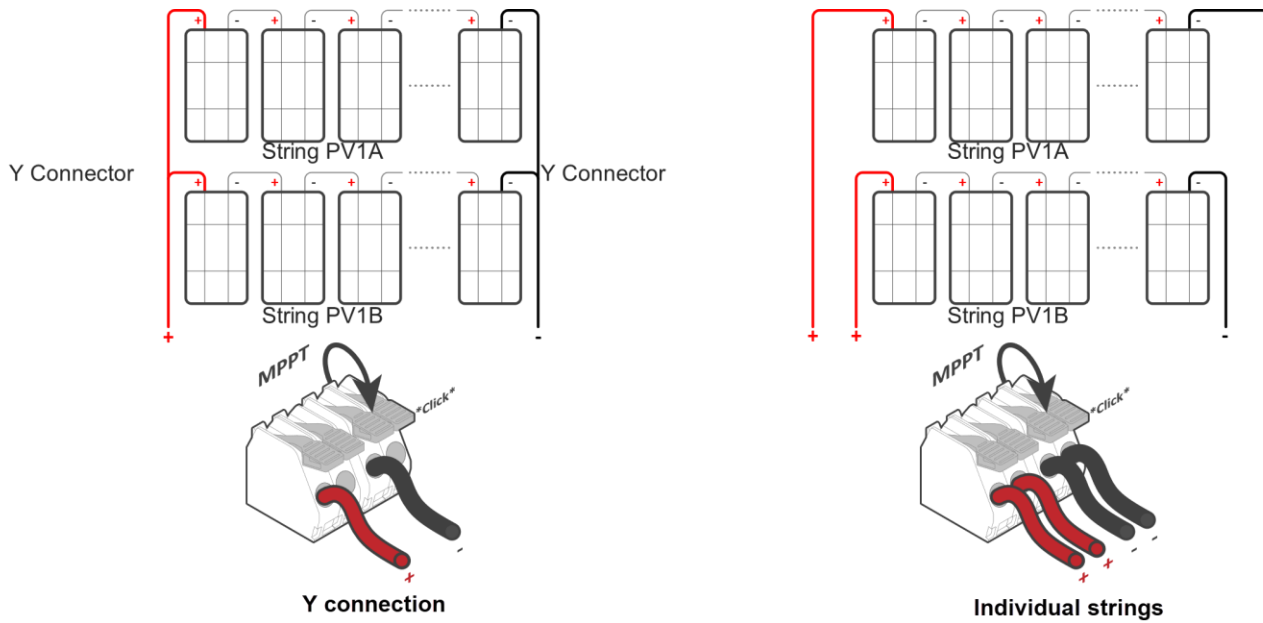

➤ Return to [Step 13. Check PV wiring polarity.](#)

More Information

Confirm Grid AC Voltage. (Step 14 Details)

Integrating a Generator

When needed, the Sol-Ark inverter can use a 240 Volt generator to charge the battery connected to the Sol-Ark via the **GEN** port.

Generators Smaller than 28.8kW > On **GEN** Terminals

- **ONLY** Supports 120/240V Split-Phase generators.
 - 120A usable on **GEN** terminal.
 - Less than 15% Total Harmonic Distortion (THD) recommended to avoid frequent disconnects
 - NOT compatible with:
 - 120V Single Phase Generators
 - 120/208V 3-Phase Generators (2 of 3 Phases)
- ⚠ Voids Sol-Ark Warranty

Generators Greater than 28.8kW > On **GRID** Terminals

Supports 220V Single phase, 120/240V Split phase, 120/208V 3-Phase (2 of 3 phases). The correct grid type must be selected before connecting the generator.

NOTE: Programming **GEN Connect to Grid Input** is required:

⚙ > **Limiters** > **Other** > **GEN Connect to Grid Input**.

⚠ **DO NOT** use **Grid Sell** in Off-Grid systems. This can potentially damage the generator. Installation of CT sensors on generator lines is required only if **Peak Shaving** will be used.

Weekly Generator Exercise

If a generator has two-wire start compatibility, it will have a weekly generator test every Monday at 8:00AM local time by default. The test takes 20 minutes to complete, and the generator will start and stop automatically. You can disable the test can by specifying: **00 | 00** min in the **Generator Exercise Cycle Day & Time** option.

More Information

Integrating a Generator (Continued)

Improve the Generator & Sol-Ark Compatibility

Navigate through the menus and program the following settings to improve the Sol-Ark and generator compatibility and operating range to avoid frequent disconnections.

A. Change the grid mode to General Standard:

⊙ > **Grid Setup** > **Grid Selection** > **Grid Mode**.

1. Tap and use the navigation arrows to cycle through the different grid modes. Choose **General Standard**.

B. Increase the frequency range of operation:

⊙ > **Grid Setup** > **Connect** > **Reconnect**

1. Increase Grid Hz High to **65Hz**.
2. Decrease Grid Hz Low to **55Hz**.

C. Increase the voltage range of operation:

1. Increase Grid Volt High to **275V**.
2. Decrease Grid Volt Low to **185V**.

NOTE: Sol-Ark will not charge the batteries using the generator unless the **Start V** or **Start %** condition is met. Only one condition (V or %) can be modified at a time, depending on the control mode selected (**Use Batt V Charged** or **Use Batt % Charged**).

➤ Return to [Step 14. Confirm Grid AC Voltage](#).

More Information

Check Grid Parameters (Step 15 Details)

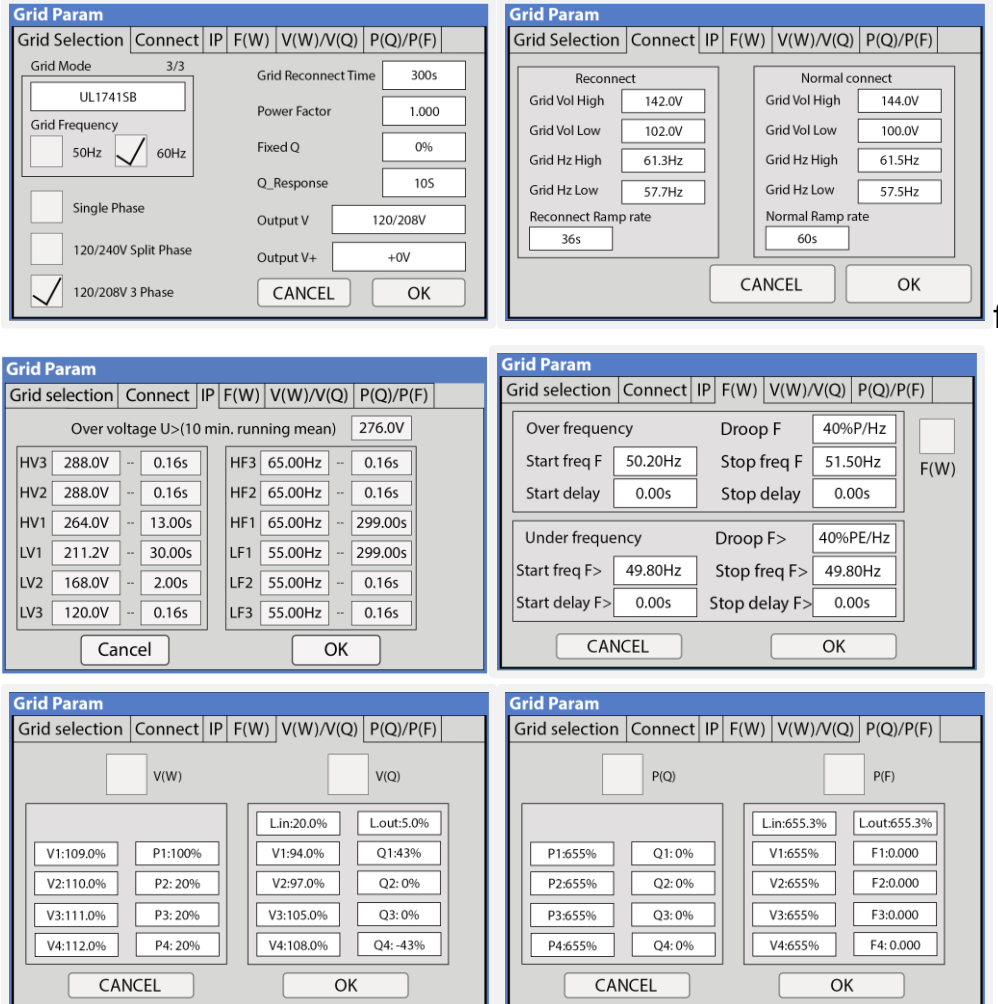

Grid Selection

Grid Mode: Tap and use navigation arrows to cycle through different grid modes:

General Standard: Applies general grid interconnection standards. Enables grid frequency and voltage adjustments (useful for off-grid applications with backup generators).

UL1741 & IEEE1547: Applies UL 1741 and IEEE 1547 grid interconnection requirements and standards.

More Information

Check Grid Parameters (Step 15 Details Continued)

SRD-UL-1741: Applies UL 1741SB grid interconnection requirements and standards.

Grid Frequency: Frequency of the AC sine wave.

Grid Reconnect Time: The amount of time in seconds the inverter will wait before reconnecting to the grid.

Fixed PF: Allows for power factor correction, ± 0.8 to **1.0**

Fixed Q: Allows for power factor correction based on desired reactive power percentage.

Grid Level: Tap and use navigation arrows to cycle through different nominal grid voltage levels.

NOTE: Grid level must be selected according to nominal grid voltage.

These are the most common Grid levels:

- LN:120VAC LL:240VAC
- LN:120VAC LL:208VAC

More Information

Check Grid Parameters (Step 15 Details Continued)

Connect

Reconnect: Parameters used to determine an allowable range of frequency and voltages to dictate a reconnection to the grid after initial grid loss. Frequency and voltages must be within these margins during Grid Reconnect Time to allow grid reconnection.

NOTE: Parameters will be set automatically based on selected grid mode compliance, unless “General Standard” is selected.

Normal connect: Parameters used to determine an allowable range of frequency and voltages to retain connection to the grid following a reconnect and normal operation.

NOTE: Parameters will be set automatically based on selected grid mode compliance, unless “General Standard” is selected.

- Reconnect Ramp Rate: Reconnection power ramp time in seconds.
- Normal Ramp Rate: Startup power ramp time in seconds.

IP

HV1/HV2/HV3: Overvoltage protection point.

LV1/LV2/LV3: Undervoltage protection point.

HF1/HF2/HF3: Over frequency protection point.

LF1/LF2/LF3: Under frequency protection point.

F(W)

F(W): Enables the use of Frequency-Watt. The Sol-Ark regulates its power output to the grid as a function of the frequency to support grid stabilization during over and under-frequency conditions.

More Information

Check Grid Parameters (Step 15 Details Continued)

Droop F: Percentage of inverter's nominal power increase / decrease per Hertz (Hz).

Start freq F: Frequency at which the inverter will start decreasing active power by the programmed Droop F percentage.

Stop freq F: Frequency at which the inverter will stop decreasing active power by the programmed Droop F percentage.

V(W) / V(Q)

V(W): Enables the use of Volt-Watt. The Sol-Ark regulates active power output to the grid as a function of voltage to support stabilization during over and under-voltage conditions.

V(Q): Enables the use of Volt-VAr. The Sol-Ark regulates reactive power output to the grid as a function of the voltage to support stabilization during over and under-voltage conditions.

V, P & Q: Percentage of nominal grid voltage (V) to which the Sol-Ark will reduce its active power (P) or reactive power (Q).

P(Q) / P(F)

P(Q): Enables the use of Watt-VAr to regulate reactive power output according to programmable active power parameters.

P(F): Enables PF regulation according to programmable active power parameters.

NOTE: Follow electrical grid code before changing grid settings.

➤ Return to [Step 15. Check Grid Parameters.](#)

More Information

Test Island Mode (Step 17 Details)

The graphic shows the detailed voltage screen when performing island test.

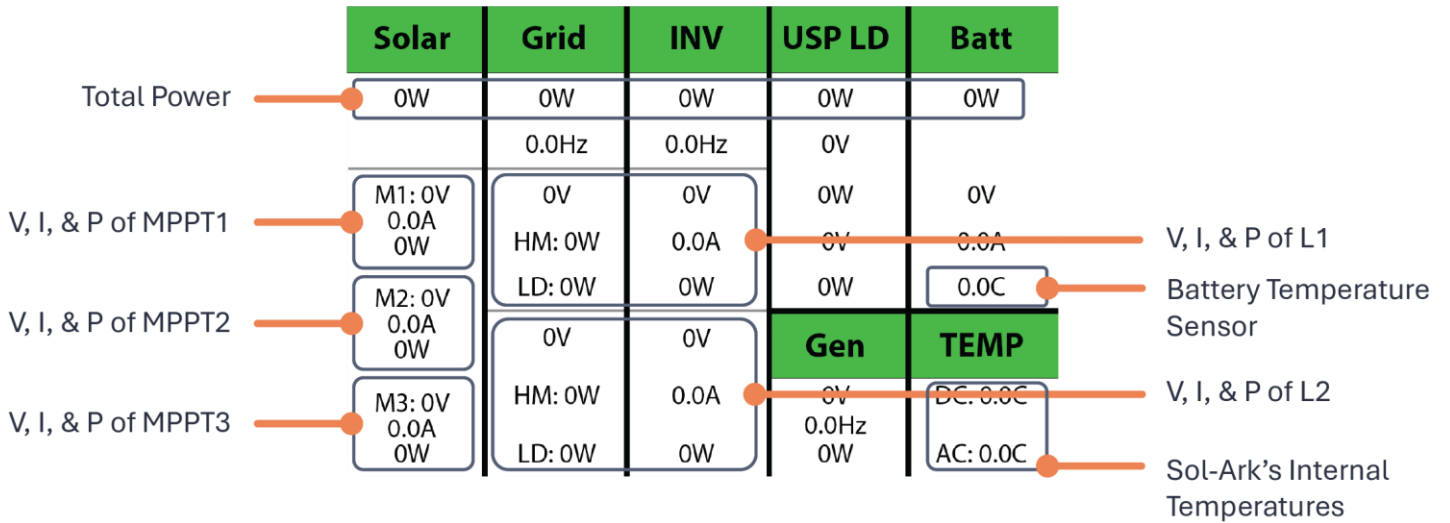

Details screen

➤ Return to [Step 17. Test Island Mode.](#)

More Information

Alternate Method for Connecting to WiFi using IP Address (Step 18 Details)

You can configure a Wi-Fi network through an IP address.

1. On a Smart Phone or Computer, connect to the **EAP-#####** network. Go to: **Settings > Wi-Fi > EAP-##### network**.
2. Type in the password, which depends on the product you received:
 - If you see **“KEY”** printed on the dongle, the 16-digit password is printed there
 - If there is no **“KEY”** printed on the dongle, the password is **12345678**

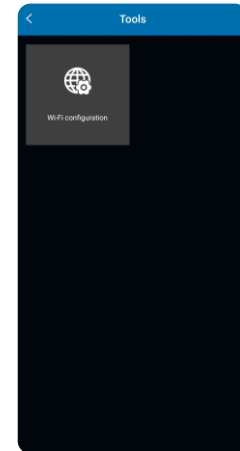

The EAP-##### network contains the last 5 digits of the Dongle serial number. You can find this number on the label.

3. A message such as “Connected without internet” appears when the device is connected to the EAP-#####.

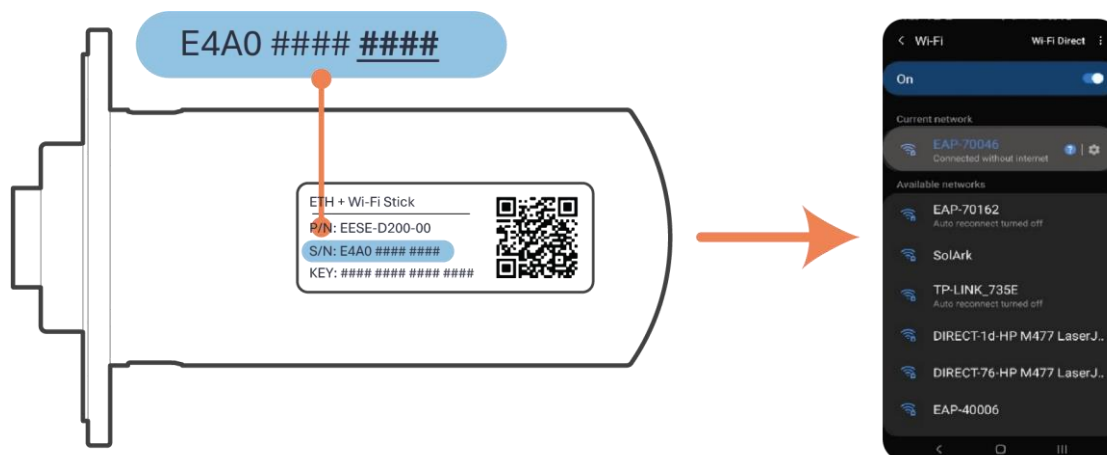

Locating the Dongle Network Name

NOTE: The Wi-Fi dongle does NOT provide internet access. It needs an external internet provider to connect to. The dongle is compatible with Wi-Fi signal broadcasted at 2.4 GHz (it is not compatible with 5 GHz networks).

More Information

Alternate Method for Connecting to WiFi using IP Address (Step 18 Details Continued)

4. After you're connected, open an internet browser on the same device, such as Safari, Chrome, Firefox, Edge, or any other browser.
5. On the address bar (http://.....), type the IP address: **10.10.10.1** as shown in the figure below. If you cannot access the configuration page, try again on a different device.
6. Scroll down to the "**Wlan Connection**" section and tap the **Scan** button to scan for local Wi-Fi networks.
7. Nearby Wi-Fi networks will appear. Select the local network you want to connect to, input your credentials, and tap **Connect**.
8. Once connected, a "Connection Successful" message will appear. Tap the **Save** button next to **Scan** to save settings.
9. Wait about 5 minutes. The dongle will connect to the Wi-Fi network and will then have access to MySolArk.

NOTE: DO NOT connect to the **EAP-####** network as that is the Wi-Fi dongle itself. The device does not provide internet access.

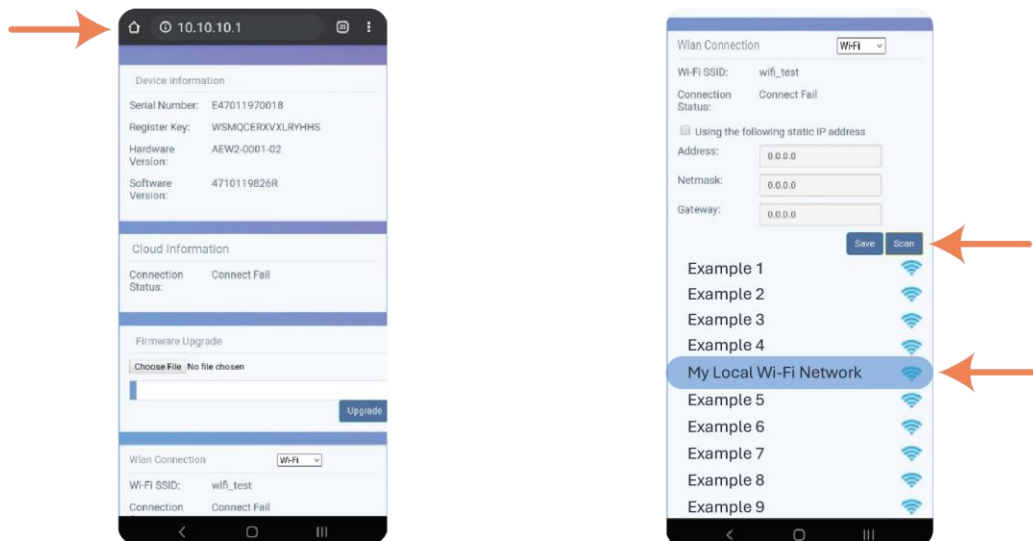

a. Internet Browser IP Address

b. Wi-Fi Network Scan

➤ Return to [Step 18. Connect the Dongle.](#)

More Information

Create a Plant on MySolArk (Step 19 Details)

1. **Download and install the MySolArk app** for Android or Apple smartphones. QR codes are provided below.



Google Play Store



MySolArk



Apple App Store

2. Create a MySolArk account and log in.

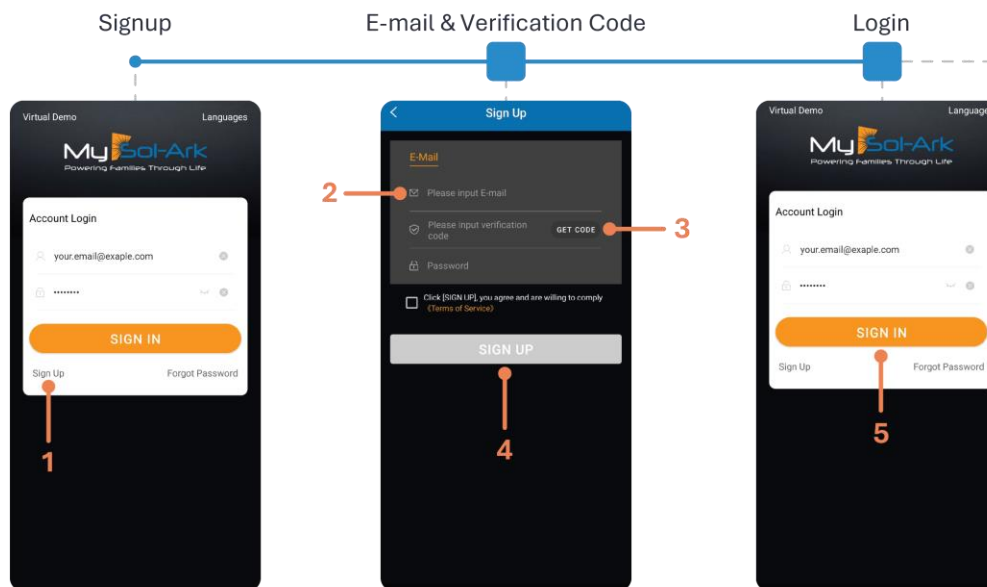

More Information

Create a Plant on MySolArk (Step 19 Details Continued)

3. Create the Plant.

For Installers:

- Create the plant and configure the system before sharing it with the owner
- After creating and configuring the plant, the installer can share and grant manager permissions to the owner by navigating to **My Plants** → ... → **Share** → **Add Account**

For Homeowners:

- The homeowner must create their own **MySolArk** account

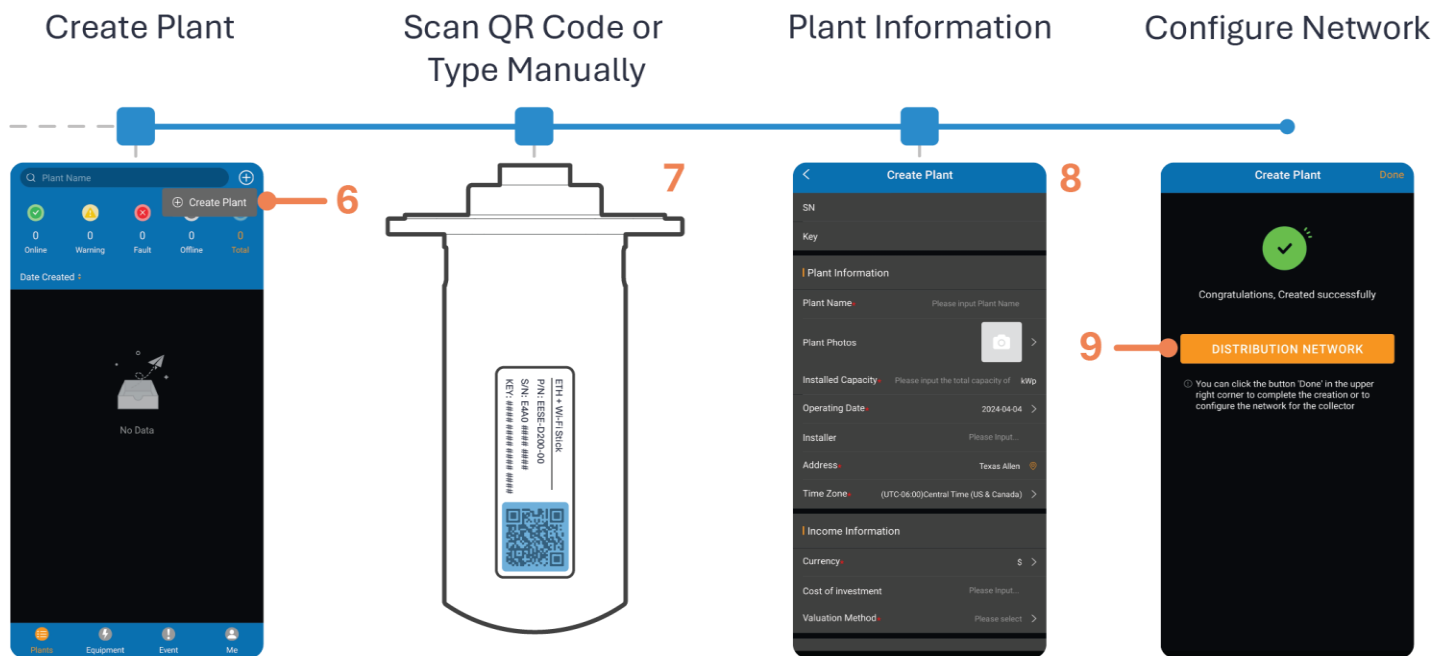

➤ Return to [Step 19. Create the plant.](#)

More Information

System Work Modes (Step 22 Details)

To access different work modes, go to **System Setup** → **Limiter** tab (3).

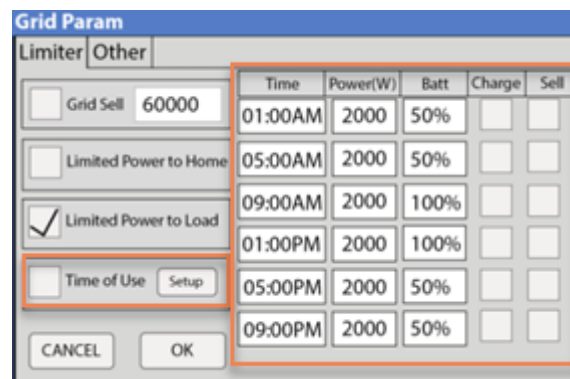
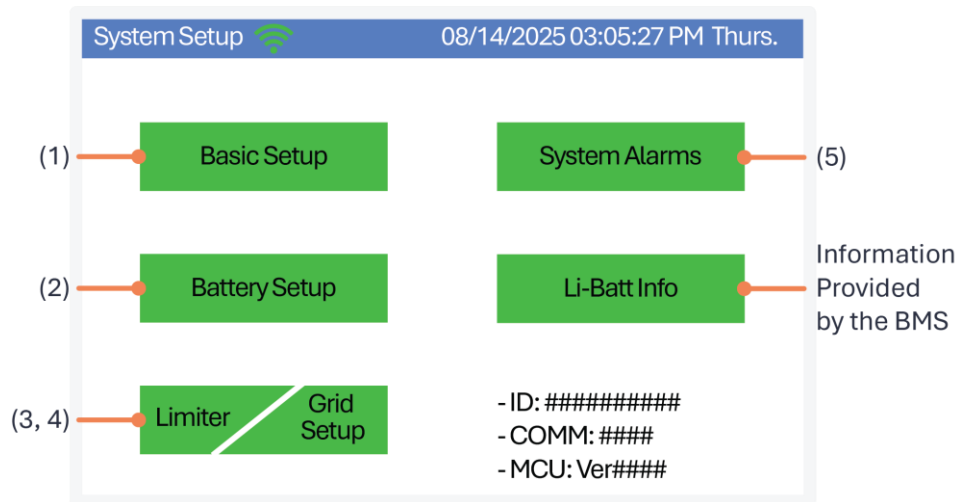

Grid sell mode

Allows excess produced PV to back-feed **GRID** input to the utility.

- Will not export power with loss of grid
- Will not export if inverter detects generator
- Maximum amount of power is determined by programmed wattage

More Information

System Work Modes (Step 22 Details Continued)

Limited Power to Home

Allows inverter to track total backup and non-backed up loads using external CTs.

- If grid sell is NOT enabled with LPH, inverter will back-feed **GRID** input with excess PV to zero non-backed loads
- If grid sell is enabled with LPH, inverter will back-feed all excess PV through **GRID** input and system will correct report export amount

Limited Power to Load

Allows inverter to track backup load power from only the **LOAD** terminals.

- If Grid Sell is NOT enabled with LPL, inverter will limit PV to cover only backup loads
- If Grid Sell is enabled with LPL, inverter will back-feed **GRID** input with excess PV to the grid sell power amount

More Information

System Work Modes (Step 22 Details Continued)

Time of Use (TOU)

The main purpose of TOU mode is for batteries to assist with load demand.

Found on the **Limitter** tab, Time of Use mode is used in conjunction with **Limited Power to Home** or **Limited Power to Load** and optionally **Grid Sell** if excess PV power is allowed to backfeed the grid. The main purpose of TOU mode is for batteries to assist with load demand.

TOU mode has six different time slots over a 24-hour period to control the batteries charge/discharge behavior during operation:

Power(W) column is the maximum amount of power batteries will send.

- Corresponding **Sell** box will force the continuous amount of power from batteries
- Corresponding **Charge** box will allow that amount of power to charge batteries from grid/generator (grid or gen charge)

Batt (%/V) column is the upper/lower limit for batteries to discharge/charge.

- With NO **Charge** or **Sell** box enabled, the batteries discharge to cover loads down to this **%/V**
- When **Charge** is enabled, batteries charge to the programmed **%/V** if below that value
- When **Sell** is enabled, batteries discharge down to the programmed **%/V**

More Information

System Work Modes (Step 22 Details Continued)

Advanced Setting – Grid Peak Shaving

Allows system to limit the amount of power imported through the GRID input. The batteries will be used as the primary source to keep peak shaving value from being exceeded.

- Can be used for a generator wired in GRID input to avoid overload scenarios
- Forces TOU settings to be enabled, so must program time slots accordingly
- It's recommended to use external CTs with this feature and enable **Limited to Home** on the **Limiter** tab

The screenshot shows the 'Basic Setup' configuration window with several tabs: Display, Time, Advanced, Factory Reset, and Parallel. The 'Advanced' tab is selected. The 'Solar Arc Fault ON' checkbox is checked, and the 'Clear Arc_Fault' checkbox is unchecked. The 'Gen Limit Power' and 'Load Limit Power' are both set to 15000W. The 'Grid peak-shaving' checkbox is checked, and its 'Power' value is set to 15000W, which is highlighted with a red box. The 'Auto detect Home Limit Sensors' checkbox is unchecked, and the 'CT ratio' is set to 2000. The 'UPS Time' is set to 0ms. On the right side, there is a list of 'ARC parameters' with values: 030000, 045000, 000400, 000050, 000390, 000055, and 238094. At the bottom, there are 'CANCEL' and 'OK' buttons.

Return to [Step 22. Check system performance.](#)

