

## 2 YEAR LIMITED WARRANTY

The SM5-KIT manufactured by Samlex America, Inc. (the "Warrantor") is warranted to be free from defects in workmanship and materials under normal use and service. The warranty period is 2 years for the United States and Canada, and is in effect from the date of purchase by the user (the "Purchaser").

Warranty outside of the United States and Canada is limited to 6 months. For a warranty claim, the Purchaser should contact the place of purchase to obtain a Return Authorization Number.

The defective part or unit should be returned at the Purchaser's expense to the authorized location. A written statement describing the nature of the defect, the date of purchase, the place of purchase, and the Purchaser's name, address and telephone number should also be included.

If upon the Warrantor's examination, the defect proves to be the result of defective material or workmanship, the equipment will be repaired or replaced at the Warrantor's option without charge, and returned to the Purchaser at the Warrantor's expense. (Contiguous US and Canada only)

No refund of the purchase price will be granted to the Purchaser, unless the Warrantor is unable to remedy the defect after having a reasonable number of opportunities to do so. Warranty service shall be performed only by the Warrantor. Any attempt to remedy the defect by anyone other than the Warrantor shall render this warranty void. There shall be no warranty for defects or damages caused by faulty installation or hook-up, abuse or misuse of the equipment including exposure to excessive heat, salt or fresh water spray, or water immersion.

No other express warranty is hereby given and there are no warranties which extend beyond those described herein. This warranty is expressly in lieu of any other expressed or implied warranties, including any implied warranty of merchantability, fitness for the ordinary purposes for which such goods are used, or fitness for a particular purpose, or any other obligations on the part of the Warrantor or its employees and representatives.

There shall be no responsibility or liability whatsoever on the part of the Warrantor or its employees and representatives for injury to any persons, or damage to person or persons, or damage to property, or loss of income or profit, or any other consequential or resulting damage which may be claimed to have been incurred through the use or sale of the equipment, including any possible failure of malfunction of the equipment, or part thereof. The Warrantor assumes no liability for incidental or consequential damages of any kind.

Samlex America Inc. (the "Warrantor")  
www.samlexamerica.com



103 - 4268 Lozells Ave.  
Burnaby, BC  
Canada V5A 0C6

T: 604 525 3836  
F: 604 525 5221  
TF: 1 800 561 5885

e-mail: samlex@samlexsolar.com  
website: www.samlexsolar.com

11013-SM5-KIT-1112  
MAN-10004



**5-hole  
Solar Panel  
Mounting  
Bracket Kit**  
  
**SM5-KIT**

**Owner's  
Manual**

Please read this  
manual before  
installing your kit

## INTRODUCTION

The SM5-KIT includes four sturdy 5-hole Aluminum mounting brackets (Fig. 1) with stainless steel hardware required to securely fasten a solar panel to the roof of your Recreational Vehicle (RV) or any other flat surface.

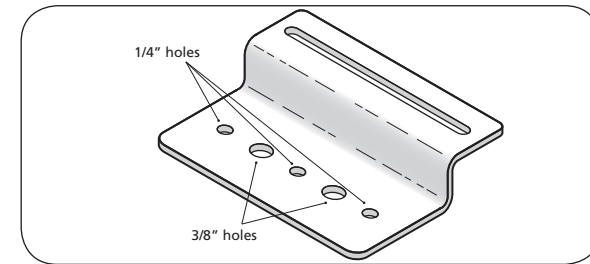

Fig.1. 5-hole mounting bracket

### List of Parts (Included in the kit)

Part Description	Quantity	Illustration
1. 5-hole aluminum mounting bracket	4	Fig. 1
2. Stainless steel serrated flange bolt 1/4"-20 x 3/4"	4	Fig. 7
3. Stainless steel nylon insert locknut, 1/4"	4	Fig. 7
4. Stainless steel flat washer, 1/4"-20	8	Fig. 7
5. Well Nut-Nut thread: 1/4"-20, length: 1", shank dia: 1/2"	4	Fig. 2
6. Stainless steel serrated flange bolt, 1/4"-20 x 1 1/4"	4	Fig. 8

### Required Tools (Not included in the kit)

7/16" wrench  
Hand Drill  
Pliers

3/8" wrench  
1/2" drill bit  
Punch or Awl

### Pre-installation

With the incidence of sunlight on all photovoltaic modules, a voltage appears at the output terminals of the photovoltaic module turning it into a live power source. To avoid a shock hazard make sure the solar module is covered with an opaque (dark) material such as paper / cloth.

Stainless Steel can be subject to a process called "thread galling" in which bolts can twist off and/or the bolt threads seize to the nut's thread. Apply anti-galling lubricant available at most hardware or auto-parts stores to all the stainless steel fasteners before installation. If anti-galling lubricant is not available, any standard lubricant will minimize the occurrence of "thread galling".

## Well Nut for anchoring mounting bracket to the RV Roof or flat surface

A Well-Nut is a bushing of tough neoprene rubber with a flange at the top end and a captive brass nut mounted within the bore at the bottom end (Fig. 2). This is used to anchor the mounting bracket (Fig. 1) on to the roof of the RV or to other flat surface. Typical installation is shown in Figs 3 to 6. Tightening a conventional machine bolt or screw engages the captive nut thereby causing the bushing to expand outwards. This fastens securely to thinner RV roofs by bulging up and against the bottom surface of the roof (Fig. 5). If used in a blind hole in a solid surface material, the rubber will expand outwards to create a secure fastening (Fig. 6). The neoprene and brass resist most environmental conditions. Additionally, the Well-Nut seals the drilled hole effectively against air and liquid leakage.

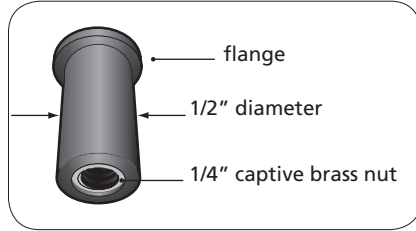

Fig. 2. Construction of a Well Nut

## Typical Installation of a Well-Nut

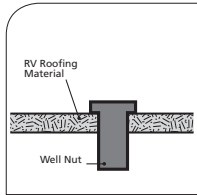

Fig. 3. Well-Nut is inserted into a pre-drilled hole with its flange against the outer surface. There is no need for access to the inner side.

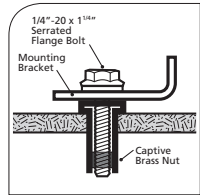

Fig. 4. The 5-hole mounting bracket is placed against the flange of the Well-Nut and is secured by the 1/4" - 20 x 1 1/4" serrated flange bolt engaging the captive brass nut.

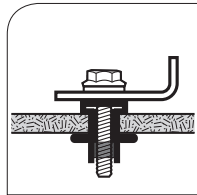

Fig. 5. As the bolt is tightened, the neoprene body of the Well-Nut is compressed and expanded, forcing it tightly into the bolt's threads and against the inner surface of the thin RV roof material.

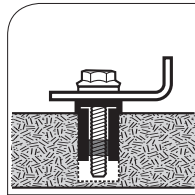

Fig. 6. Installed in a blind hole in a solid material, the body of the Well-Nut expands tightly against the walls of the hole, effecting a secure, dependable fastening.

## INSTALLATION PROCEDURE

1. Determine the position of the solar panel on the RV roof or flat surface. While positioning panels, avoid shading of the solar panel by neighbouring obstacles such as vents, air-conditioners, TV antennas etc. As far as possible, position the panels to minimize wiring distance between the solar panel and the charge controller. Place the panel at least 8-10 inches away from the RV roof edges and leave sufficient space to walk around the panel and access the mounting hardware.
2. Make sure the thickness of the roof at the installation location is at least 1/2" thick and the material is strong enough to provide mechanical support to the solar panel and mounting hardware against possible wind loading. Place the panel length-wise to reduce the effects of wind loading on the RV.
3. Fix the mounting brackets to the frame of the previously positioned solar panel using the slotted opening and the 1/4" - 20 x 3/4" Flange Bolt, Nylon Locknut and flat washer (Fig. 7). Using a 7/16" wrench, tighten the nuts to secure the mounting brackets to the PV panel. Recommended tightening torque is 15 lbs.

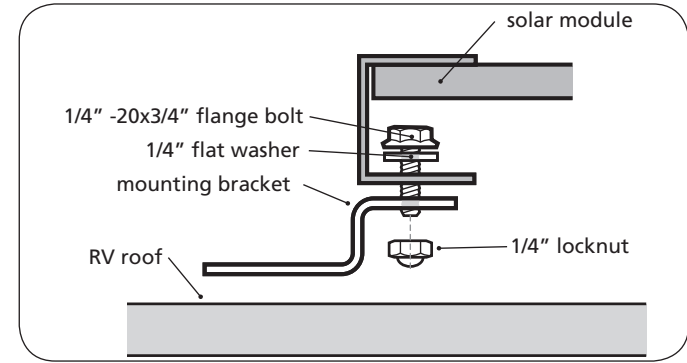

Fig. 7. Attaching solar panel to 5-hole mounting bracket

4. Position the panel with the attached mounting brackets at the desired location on the RV roof and mark the position of the mounting holes by tracing the hole in the mounting bracket. Please ensure that the mounting surface on the RV roof is strong enough to support the mounting hardware, solar panel and wind loads.
5. The centre and end holes on the mounting brackets (Fig. 1) are sized to accept the 1/4" hardware supplied with the kit. If the use of larger sized hardware is desired, holes 2 and 4 can be used.
6. To install the Well-Nuts, for anchoring the brackets to the RV roof or a flat surface, drill holes 1 1/4" deep at the marked positions using a 1/2" size drill bit. Make sure that drilling does not interfere with pre-existing wiring installations.
7. Apply silicone or any appropriate sealant recommended by your RV dealer generously to the drilled holes for water-proofing.
8. Insert the 1/4" Well-Nut into the drilled holes so that only the flange section remains above the roof surface (Fig. 3).
9. Fasten the mounting brackets to the roof surface by inserting the 1/4 x 1 1/4" serrated flange bolt into the Well-Nut. Tighten using a 3/8" wrench to a recommended torque of 15 lbs. When the serrated flange bolt is screwed into the Well-Nut, the material surrounding the well nut bulges slightly securing the structure to the RV roof (Fig. 5, 8).
10. Ensure that all fasteners are tightened to the recommended tightening torque.
11. Make sure all bolts and mounting brackets are covered by good amounts of suitable RV sealant recommended by your local RV dealer.

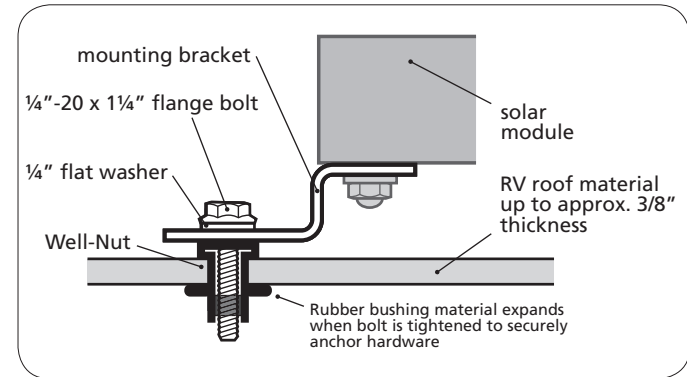

Fig. 8. Attaching 5-hole mounting bracket to RV roof