

COTEK

SR Series

1KW Pure Sine Wave Power Inverter

User's Manual



CE FC

Contents

1. Important Safety Instructions.....	3
1-1 General Safety Precaution.....	3
1-2 Other Safety Note.....	3
2. Introduction to Functional Characteristics.....	4
2-1 System.....	4
2-2 Block Diagram.....	5
2-3 Electrical Performance.....	6
2-4 Mechanical Drawings.....	7
3. Installation and Maintenance.....	8
3-1 Rear Panel.....	8
3-2 Deutsch Wichtige Sicherheitshinweise.....	13
3-3 Front Panel.....	15
3-4 Maintenance.....	16
4. Operation.....	16
4-1 Connecting the Input Power.....	16
4-2 Connecting the Loads.....	16
4-3 Inverter Operation.....	16
4-4 Protection Features.....	17
5 Front LCD Panel Display and Setup.....	17
5-1 LCD Panel Indications.....	17
5-2 Startup Sequence and Standby Status.....	19
5-3 Setup Menu Operation and Instructions.....	20
6. RS232 Communication and Operation.....	25
6-1 Operation of RS-232 Serial Port.....	25
6-2 Interface Command.....	26
6-3 Example of RS232 Operation.....	26
7. Information.....	31

7-1	Troubleshooting.....	31
7-2	Warranty.....	31
8.	Appendices.....	31
8-1	FCC (Class B) Declaration of Conformity.....	32
8-2	EMC Declaration of Conformity.....	33
8-3	TUV(EN60950) Declaration of Conformity.....	34

1. Important Safety Instructions

**WARNING!**

SAVE THESE INSTRUCTIONS – This manual contains important instructions that should be followed during installation and maintenance of the inverter.

1-1. General Safety Precautions

- 1-1-1. Do not expose the inverter to rain, snow, spray or dust. To reduce the risk of fire hazard, do not cover or obstruct the ventilation openings and. do not install the inverter in a zero-clearance compartment.
- 1-1-2. To avoid the risk of fire and electric shock, make sure that the existing wiring is in good electrical condition; and that the wire size is not undersized.
Do not operate the inverter with damaged or substandard wiring.
- 1-1-3. Depending on the use, the AC output of the inverter may require user installed breaker or fusing. For telecom use, a GFCI has not been provided. The inverter incorporates standard AC short circuit protection.
- 1-1-4. The following precautions should be taken when working on the inverter:
 - Remove watches, rings, or other metal objects.
 - Use tools with insulated handles.
 - Wear rubber gloves and boots.

1-2. Other Safety Notes

- 1-2-1. Upon receipt, examine the shipment box for damage. Notify the carrier immediately, before opening, if damage is evident.
- 1-2-2. Do not operate near water or in excessive humidity.
- 1-2-3. Do not open or disassemble the inverter, warranty may be voided.
- 1-2-4. The DC side connections should be firm and tight.
- 1-2-5. Grounding: Reliable grounding of rack-mounted equipment should be maintained.
- 1-2-6. Do not drop a metal tool on the battery. The resulting spark or short-circuit on the battery or on the other electrical part may cause an explosion.

- 1-2-7. Install the inverter in a well-ventilated area. Do not block the front air vents, or the rear air exhausts of the unit.
- 1-2-8. Wiring: Adequate input power must be supplied to the inverter for proper use; correct wiring sizes must be ensured.
- 1-2-9. Mount the inverter such that the fan axis is horizontal.
- 1-2-10. Do not operate the inverter close to combustible gas or open fire.
- 1-2-11. Do not operate appliances that may feed power back into the inverter.
- 1-2-12. Temperature: The inverter should be operated in an ambient temperature range of 0°C to 50 °C or else the output efficiency may be affected. Air flow to the inverter must not be restricted.

2. Functional Characteristics Introduction

2-1. System

The unit is a highly reliable DC-AC inverter system, designed with advanced power electronic and microprocessor technology offering the following features:

- The inverter is equipped with a self diagnosis microprocessor that is able to identify and show all failure messages on the LED/LCD display, with associated visual/audio alarms.
- 1U height x 19" width x 13.6" depth, 19" rack mountable.
- Pure sine wave output (THD < 2%) to operate higher-end electronic equipment.
- Built in 15A(120VAC) and 10A(250VAC) rated Bypass relay.
- Speeds up transfer time as a result of synchronized operation with the AC source at all times that allows the transfer to be interruption-free for sensitive equipment.
- Intelligent software for power management.
- AC Inlet and Dual AC outlets connection model option.
- Loading and temperature controlled cooling fan.
- Fan aging, failure, disconnection and blockage alarm.
- Selectable Bypass/Inverter modes.
- Local and remote management and control.

- RS-232 communication.
- Dry contact terminal.
- Efficiency >90%. (Full linear load at 220VAC Output)
- Advanced Protection Features:
 - Input over/under voltage protection.
 - Internal over temperature protection.
 - Input reverse polarity protection (Fuse).
 - Output overload protection.
 - Output short circuit protection
 - AC input short circuit protection: Breaker (6 Amp or 12 Amp)

2-2. Block Diagram

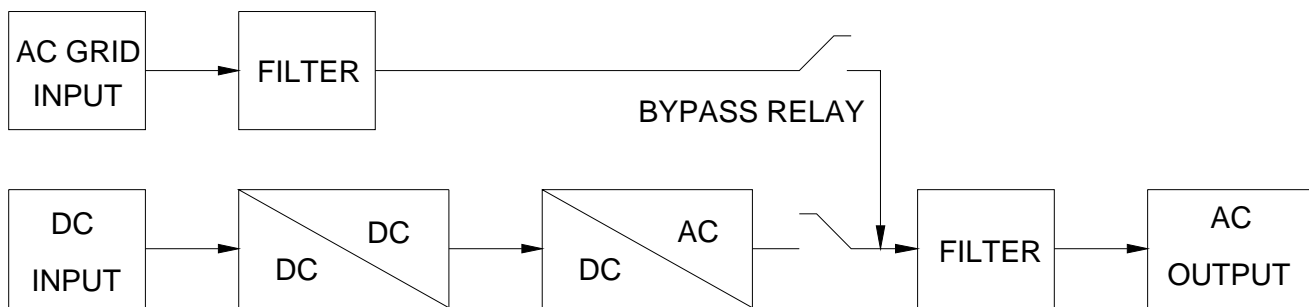

The inverter features IGBT technology which, minimizes weight and dimension, while enhancing output short circuit reliability and overload capacity.

AC output voltage is provided in one of the two following modes:

- 1). From DC to AC Inverter Mode: (On-line Mode)
- 2). From AC Input Bypass Mode: (Off-line Mode)

Either mode is front panel programmable.

In the first option, **Off-line mode**, AC output power will be supplied through the AC bypass mode in its normal operation. Upon AC input failure, output power will be diverted through the DC to AC Inverter Mode. Once AC mains are restored, the unit will revert from the Inverter Mode to the Bypass Mode.

In the second option, **On-line mode**, AC output power will be provided directly by the inverter from the DC source. Should the DC source or inverter fail, the system will transfer its output power through the bypass mode. Once the DC power source is restored, the system will revert to the inverter mode.

2-3. Electrical Performance

Electrical	Specification	Model No.			
Input Characteristics	Item	SR1000-124	SR1000-148	SR1000-224	SR1000-248
	Voltage	24 VDC	48 VDC	24 VDC	48 VDC
	Input Over-Voltage Protection	30~34 VDC	60 VDC MAX.	30~34 VDC	60 VDC MAX.
	Input Under-Voltage Protection	18~22 VDC	36~44 VDC	18~22 VDC	36~44 VDC
	Voltage Range	18~34 VDC	36~60 VDC	18~34 VDC	36~60 VDC
	No Load Current	1.4 A	0.75 A	1.3 A	0.7 A
Output Characteristics	Continuous Output Power	1000 W			
	Maximum output Power (3Min)	1100 W			
	Surge Power	2000 W			
	Frequency	47 ~ 63 Hz +/- 0.05 % (User-selectable)			
	Output Voltage	97~123 VAC (User-selectable)		194~246 VAC (User-selectable)	
	Efficiency (Full Load)	87%	88%	90%	91%
	Short-Circuit Protection	Yes , I _{pk}			
	Output Waveform	Pure Sine Wave (THD < 2%)			
Signal and Control	LCD Panel	2 Lines LCD Panel with keypad for navigation			
	LED Indicator	Red / Orange / Green LED			
	Dry Contact Terminal	By a relay			
	Remote Control Terminal	Controls the inverter ON / OFF operation			
Protection	Input Protection	Over / Under Voltage, Reverse Polarity (Internal Fuse)			
	AC Output Protection	Short-Circuit, Overload			
	AC Input Protection	12 Amp Circuit Breaker		6 Amp Circuit Breaker	
	Temperature protection	Shutdown (Internal temperature ≥ 65°C)			
Bypass Relay	Relay Specification	15Amp / 120VAC , 10 Amp / 250 VAC			
	Bypass relay selectable	On Line/Off Line (Haphazard, Normal, Exacting) selectable			
	Switching Time	From AC bypass mode(Off-line Mode) : ≤20mS From DC to AC inverter mode(On-line Mode) : ≤8mS			
Operating Temperature	Full Load	0 °C ~ 50 °C			
	Storage	-30 °C~70 °C			
Fan Operation and Indicator	Failure Indication	Buzzer alarm and dry contact			
	Switches On when	Internal Temperature ≥55°C or Load ≥30%			
	Switches Off when	Internal Temperature ≤45°C and Load ≤20%			
Mechanical Specification	Size (W X H X D)	19"x1.71"x13.6"(482.6mmX43.5mmX345mm)			
	Weight	5.8 Kgs (12.7 Lbs)			
Safety and EMS	Safety Standards	Meets UL60950	Meets EN60950-1		
	EMC Standards	FCC Class B	EN55022: 1998+A1: 2000+A2: 2003 Class B EN55024: 1997+A1: 2001+a2: 2003 EN61000-3-2: 2006 Class A EN61000-3-3: 1995+A1: 2001		

Note: The specifications are subject to change without notice.

2-4. Mechanical Drawings

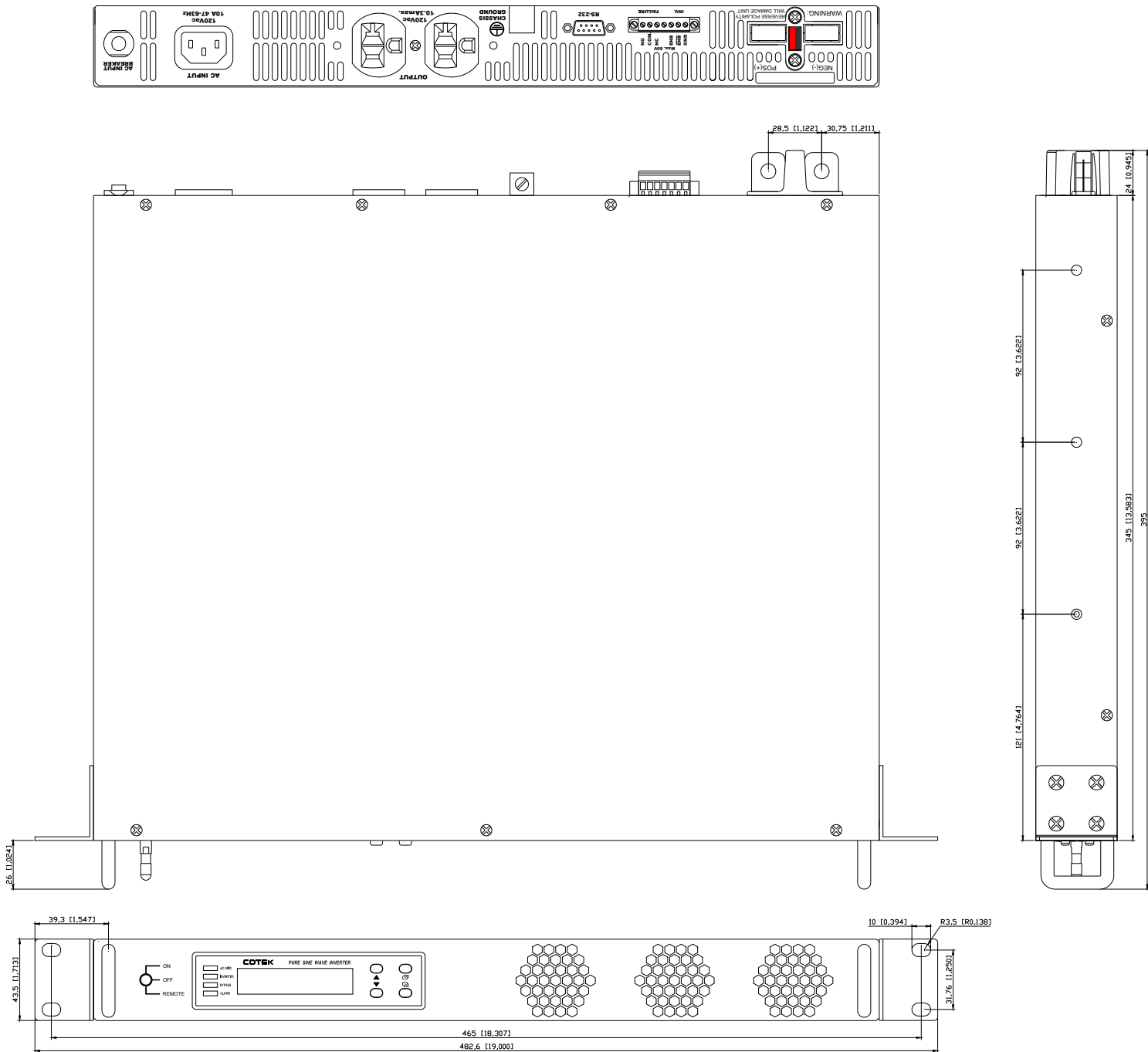

SR Series Inverter Ordering Information

Model Number	Input Voltage	Output Voltage Nominal	Output Voltage Range	Frequency Range
SR1000-124	24 VDC	110 VAC	100~120 VAC	47~63 Hz
SR1000-224	24 VDC	230 VAC	200~240 VAC	47~63 Hz
SR1000-148	48 VDC	110VAC	100~120 VAC	47~63 Hz
SR1000-248	48 VDC	230VAC	200~240 VAC	47~63 Hz

3. Installation and Maintenance

3-1. Rear Panel

REAR PANEL VIEW

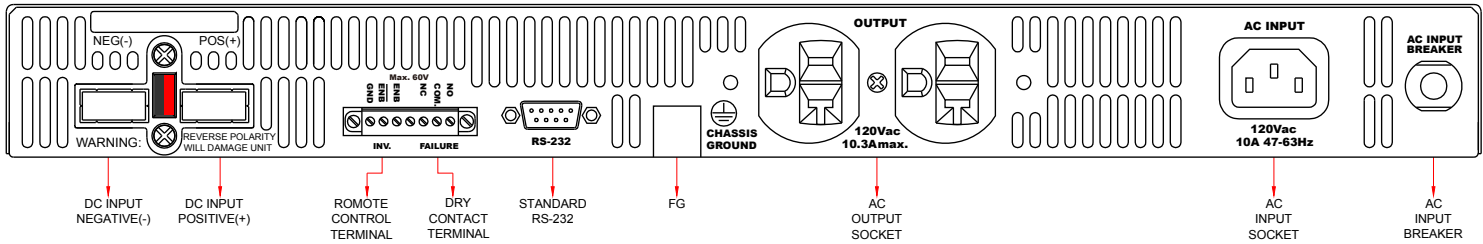

3-1-1. AC Input Breaker:

The AC input circuit breaker protects the unit from overload. When an overload condition occurs, the circuit breaker trips and disconnects the AC grid power input. To reset it, push the circuit breaker button. The cause of tripping should be ascertained and corrected before the unit is reset .

3-1-2. AC wiring connections:

■ AC socket:

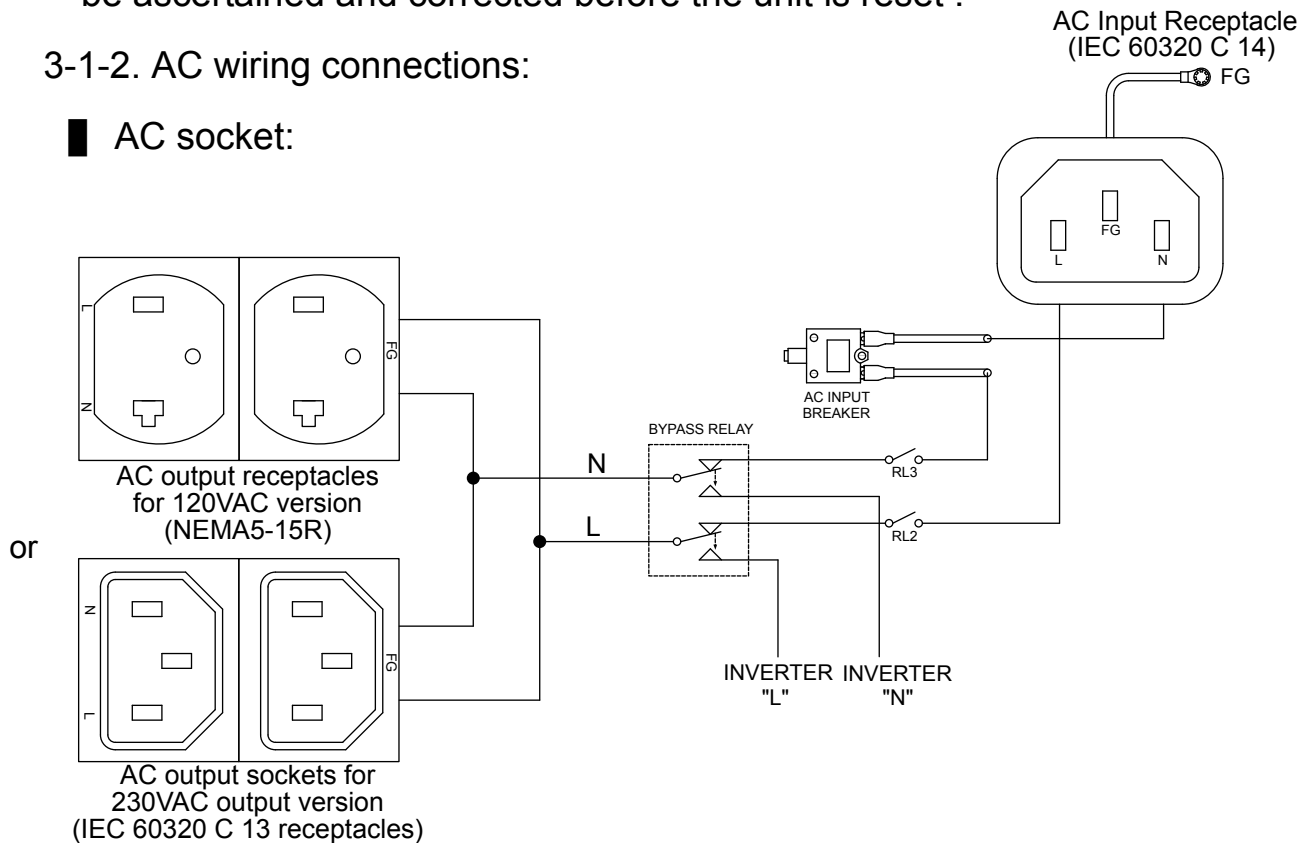

■ Connect AC input wiring to the Inverter socket.

Please use the following information as your reference:

3-1-3. AC output socket:

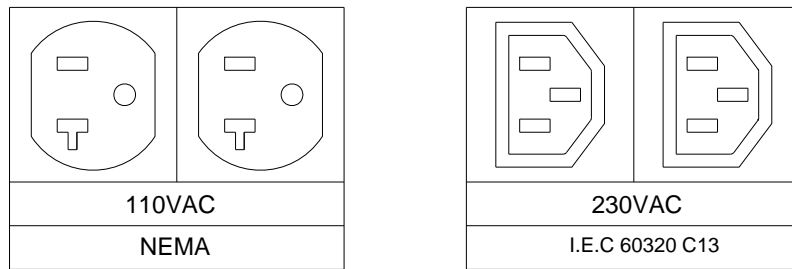

Socket		Wire color		Wire length / gauge
		120 VAC	230 VAC	
AC Output	Line (L)	NEMA	I.E.C C13	Within 16 feet / AWG# 14~16 26~32 feet / AWG# 12~14
	Neutral (N)			
AC Input	Line (L)	I.E.C C14		
	Neutral (N)			
Chassis Ground		Green / Yellow or Bare copper		

Note. Please double check and review all the connections to ensure that the wires are connected to the correct inlet.

3-1-4. Chassis Ground: Must be connected to earth ground prior to making any other connections to the equipment.

3-1-5. RS-232: Serial port monitoring and control through computer interface.

3-1-6. Remote control and Dry contact terminal:

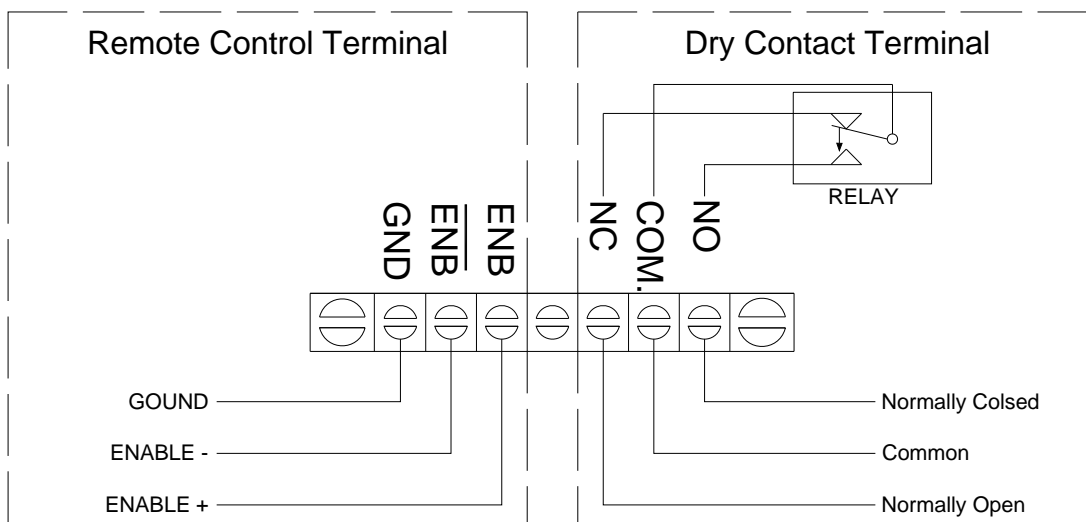

■ Remote Control Terminal:

- 1). Before installing the inverter, ensure that the main switch “OFF”.
- 2). Before using the remote function, ensure that the main switch pressed toward “REMOTE”.
- 3). Ensure that the remote contacts are off.
- 4). Use 20 ~ 24 #AWG wire to connect the remote control terminals.
- 5). Remote control ON/OFF inverter setup status:

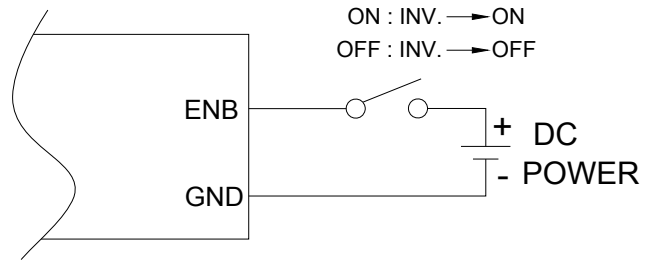
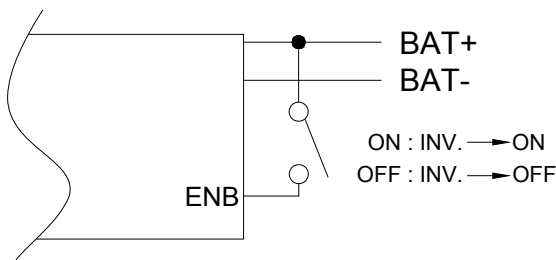
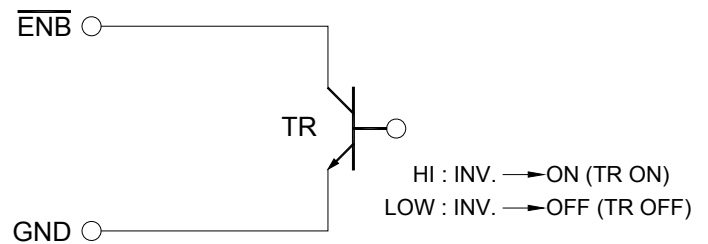
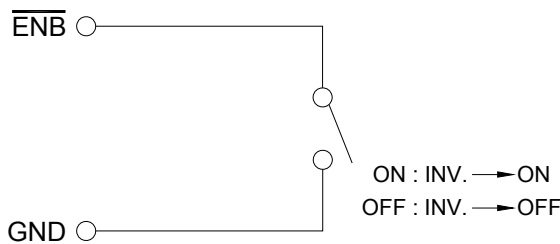

NOTE: At one time, only one remote function should used to control the inverter.
The maximum voltage value is 60VDC.

■ **Dry Contact Terminals:**

Dry contact terminals may be connected to a Form C relay for “FAULT” indication. When “FAULT” occurs, the relay switches.

NOTE: Fault conditions include Input under/over voltage, Output Short Circuit, Over Temperature, Over-load and, Fan Failure.

Specifications of the Relay

Maximum Voltage	Load	Contact Rating		Number of operations	Operating/Storage Temperature
		N.O.	N.C.		
240 VAC	Resistive	16 A	—	100,000	-30°C~70°C
240 VAC	Resistive	—	8 A	—	
30 VDC	Resistive	16 A	—	—	
30 VDC	Resistive	—	8 A	—	

■ **Remote Control Terminal:**

Dry Contact Terminal	Relay
COM.	Common contact
N.C.	Normally closed contact
N.O.	Normally open contact

3-1-7. DC Input Connection:

Follow the instructions to connect the battery cables to the DC input terminals of the inverter. The cables should be as short as possible (less than 6 feet / 1.8 meters ideally) so that they can handle the required current in accordance with the Electrical Codes and Regulations. The size of the cable should be thick enough to limit the voltage drop to less than 2% when carrying the maximum input current to prevent frequent low-input voltage warnings, and shutdown. UVP (Under Voltage Protection) warning may result if there is excessive voltage drop across the DC cables between the batteries and the inverter. Increasing your DC cable size will help improve the situation.

Batteries are capable of providing very large currents in case of short circuit. In case there is a short circuit in the cable run between the batteries and the input terminals of the inverter, it will result in overheating / melting of the cables and consequent risk of fire and injury. To prevent possibility of this hazard, use Very Fast Acting DC Fuse in line with the positive cable. The fuse should be as close to the positive battery terminal as possible. Use Bussmann ANN series fuses (will also require Fuse Block 4164) or equivalent.

The following sizes of cables and fuses are recommended for up to 6 ft. distance between the batteries and the inverter. (Applies to both 120 VAC and 230 VAC versions):

Model No	Wire AWG	Inline Fuse
SR1000-124 / 224	# 4	80 A
SR1000-148 / 248	# 6	40 A

- Connect DC input terminals to 24V / 48V battery or other DC power source. [+] is positive, [-] is negative. Reverse polarity connection can blow the internal fuse and may damage the inverter permanently.



WARNING!
 Make sure that all the DC connections are tight (torque to 9 – 10 ft-lbs, 11.7 – 13 Nm). Loose connections could result in overheating and can be a potential hazard.

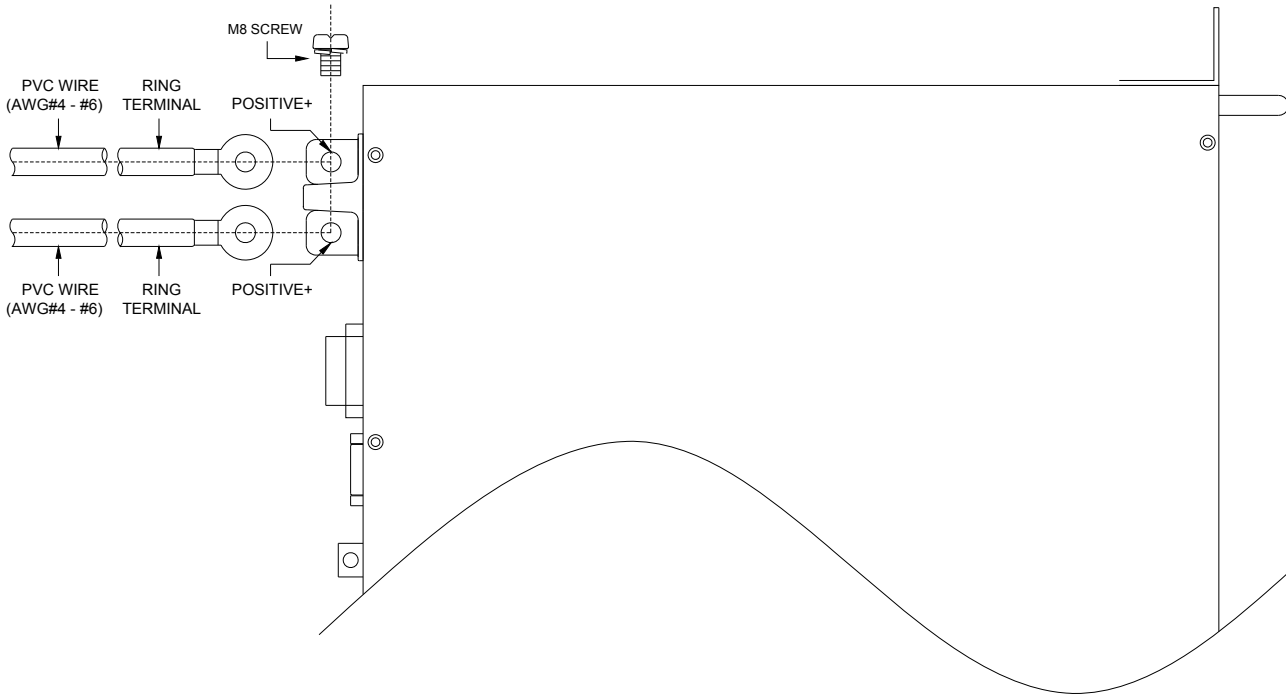



WARNING!
 The recommended inline fuse should be installed as close to the battery positive terminal as possible. Failure to use a fuse on the “+” cable running between the inverter and battery may cause damage to the cable / inverter and will void warranty.

Also, only use high quality copper wire and keep the cable length short which is a maximum of 3 - 6 feet.

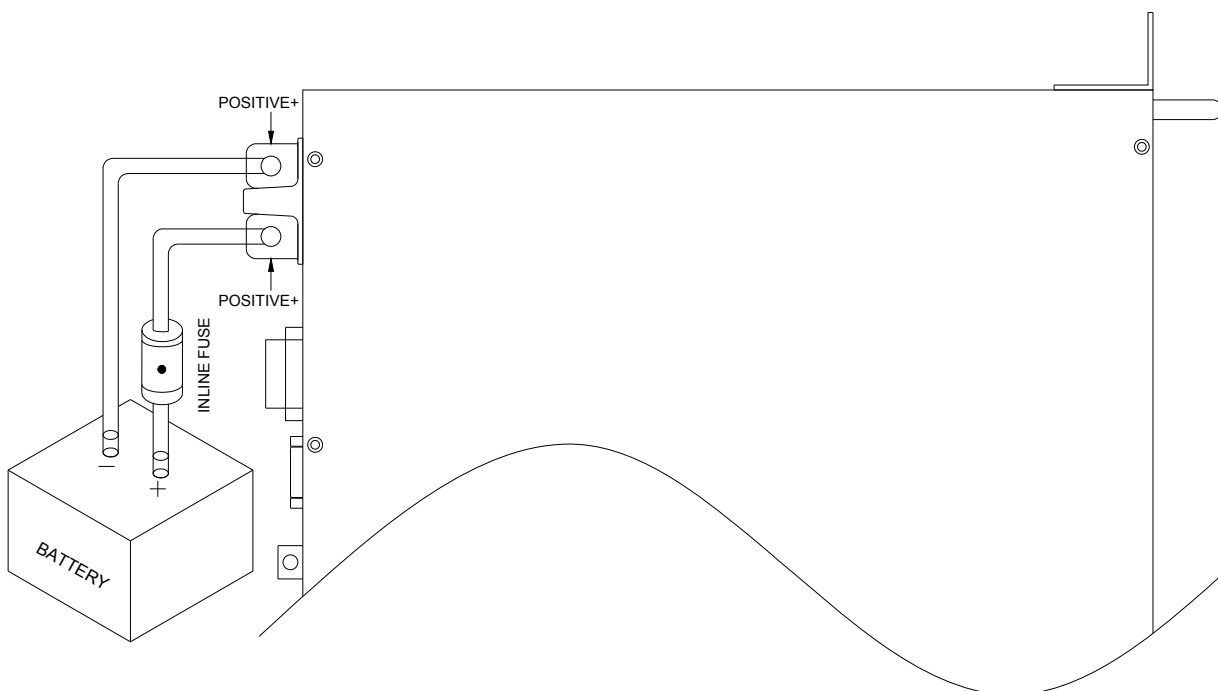

3-2. Wichtige Sicherheitshinweise

Modelle: SR1000-224, SR1000-248

Nennwerte:

DC Eingangs Spannung / Strom: 18.0 – 34.0 Vdc, 69 A. (für Modell SR1000-224)

DC Eingangs Spannung / Strom: 36.0 – 60.0 Vdc, 35 A. (für Modell SR1000-248)

AC Eingangs Spannung: 200 – 240 Vac, 50 Hz, 5 A.

Ausgangs Spannung: 194 – 246 Vac, 47 – 63 Hz, 5.16 A.

1. Bitte lesen Sie diese Hinweise sorgfältig durch.
2. Heben Sie diese Anleitung für den späteren Gebrauch auf.
3. Vor jedem Reinigen ist das Gerät vom Stromnetz zu trennen. Verwenden Sie keine Flüssig- oder Aerosolreiniger. Am besten eignet sich ein angefeuchtetes Tuch zur Reinigung.
4. Das Gerät ist vor Feuchtigkeit zu schützen.
5. Bei der Aufstellung des Gerätes ist auf sicheren Stand zu achten. Ein Kippen oder Fallen könnte Beschädigungen hervorrufen.
6. Beachten Sie beim Anschluss an das Stromnetz die Anschlusswerte.
7. Verlegen Sie die Netzanschlussleitung so, dass niemand darüber fallen kann. Es sollte auch nichts auf der Leitung abgestellt werden.
8. Alle Hinweise und Warnungen, die sich am Gerät befinden, sind zu beachten.
9. Öffnen Sie niemals das Gerät. Das Gerät darf aus Gründen der elektrischen Sicherheit nur von autorisiertem Servicepersonal geöffnet werden.
10. Wenn folgende Situationen auftreten ist das Gerät vom Stromnetz zu trennen und von einer qualifizierten Servicestelle zu Überprüfen:
 - a. - Netzlabel oder Netzstecker sind beschädigt.
 - b. - Flüssigkeit ist in das Gerät eingedrungen.
 - c. - Das Gerät war Feuchtigkeit ausgesetzt.
 - d. - Wenn das Gerät nicht der Bedienungsanleitung entsprechend funktioniert oder Sie mit Hilfe dieser Anleitung keine Verbesserung erzielen.
 - e. - Das Gerät ist gefallen und/oder das Gehäuse ist beschädigt.
 - f. - Wenn das Gerät deutliche Anzeichen eines Defektes aufweist.
11. Dieses Schaltnetzteil kann bis zu einer Außentemperatur von maximal 50°C betrieben werden.
12. Der Schalldruckpegel in der Operatorposition entsprechend IEC 60704-1 1982 ist gleich oder weniger als 70dB(A)
13. Zum Netzanschluss dieses Gerätes ist eine geprüfte Leitung zu verwenden. Es ist eine Leitung vom Typ: H03VV-F, H05VV-F, 3G, 0.75mm² oder besser einzusetzen.
14. Wechselstrom Eingangs Überstrom-Schutz: 6 Ampere Stromunterbrecher. Die folgenden Größen des Kabels für Erdleitung des CHASSIS:

Modell Nummer	Leitungs-Diameter [mm]
SR1000-124 / 224	5.19
SR1000-148 / 248	4.11

Den DC Eingang an eine 24V/48V Batterie oder am eine andere DC Spannungsquelle anschließen. [+] ist positiv, [-] ist negativ. Umgekehrter Anschluss kann zum durchbrennen der internen Sicherung führen und kann den Inverter dauerhaft beschädigen.

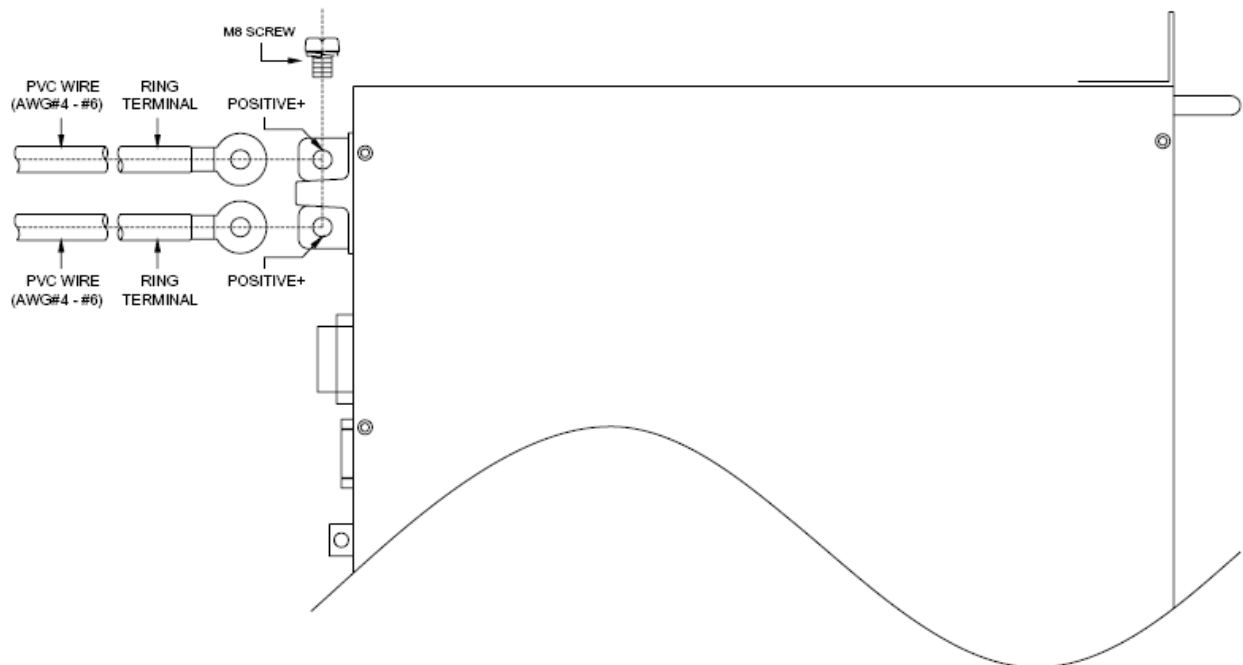

ANWENDEN

Die empfohlene Interne Sicherung sollte so nah wie möglich zur Plus-Klemme der Batterie angebracht werden. Ohne eine Sicherung zwischen dem „+“ Anschluss der Batterie und dem Kabel, das zwischen den Inverter und die Batterie läuft, kann das Kabel oder der Inverter beschädigt werden. In diesem Fall wird die Garantie ungültig.

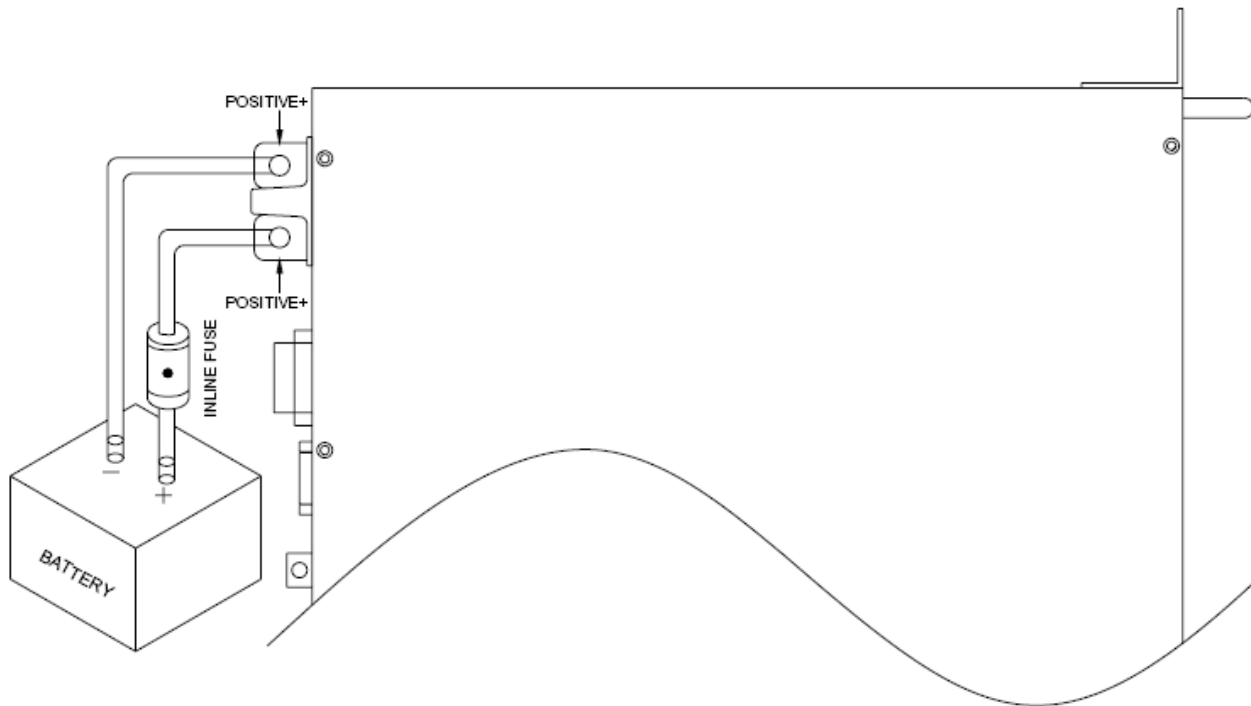

- 16. Vor Gebrauch muss dieses Gerät an einen zuverlässigen Schutzleiter angeschlossen werden.
- 17. Dieses Gerät ist vorgesehen für Installation in eine Betriebsstätte mit beschränktem Zutritt und der DC Eingangsanschluss muss an die Rückseite des Baugruppenträgers angebracht werden um zu verhindern das es durch qualifiziertes Service-Personal berührt wird.

3-3. Front Panel

FRONT PANEL VIEW

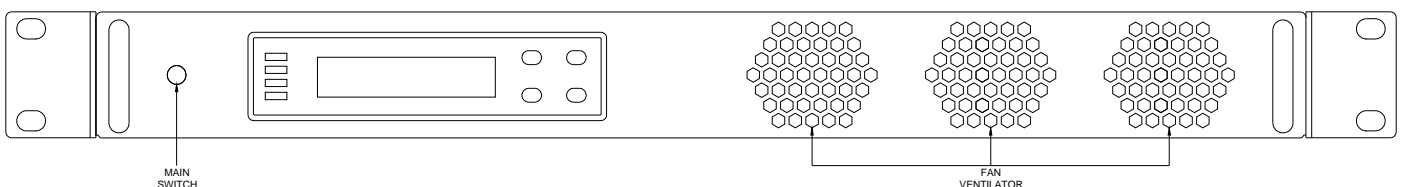

- 3-3-1. Main Switch: These are the 3-stage rocker switches for turning on, turning off and remote mode.
- 3-3-2. LED's Indicators: See details in Section 5-1.
- 3-3-3. LCD Display Selection Buttons:

Data pertaining to the DC input voltage, AC output voltage, AC output frequency, AC output current, etc. and system status can be shown sequentially on the LCD display by pressing these buttons. Please refer to chapter 5 for more information.

3-3-4. FAN ventilation grille (1)~(3): The fans behind the ventilation grilles provides cooling. **DOT NOT** obstruct these vents!

3-4. Maintenance

3-4-1. Make sure that the fan vents are not blocked.

3-4-2. Use a vacuum cleaner to remove any dust from the fan area.

3-4-3. When cleaning the case or front panel, use a soft, dry cloth, only. If the case or front panel is very dirty, use a neutral, non-abrasive detergent. Do not use alcohol or ammonia based solutions.

3-4-4. Regular service, and relocation of the inverter, should be performed by a qualified service technician.

3-4-5. Avoid spilling liquid on the inverter.

4. Operation:

4-1. Connecting the input power

Before making the DC input side connections, the main switch must be "OFF".

4-2. Connecting the loads

- Calculate the total power consumption(W) of the output load. Make sure that the total power consumption does not exceed the rated load.
- Should the total load exceed the rated capacity of the inverter, remove the non-critical. loads until the rated total has been reached.

4-3. Inverter Operation

- Set the power switch to the "ON" position. The buzzer will sound "beep beep". The inverter will carry out self-diagnosis and, the LED's will also appear various colors. At the, same time the LCD will display "SR-1000 INVERTER INITIALIATION..".
Finally, the buzzer will sound another "beep" and the "INVERTER" and

status LED's will turn "Green", The LCD Display will display "Vi, Vo, FQ, Io". THE, inverter will start operating normally.

- Set the power switch to the "OFF" position. THE, inverter stops and all the lights that are on will, go off.

4-4. Protections Features

Model	DC Input (VDC)					Over Temperature Protection			
	Over Voltage		Under Voltage Alarm	Under Voltage		INTERIOR		HEAT SINK	
	Shut-down	Restart		Shut-down	Restart	Shut-down	Restart	Shut-down	Restart
24 V	30.1~34.1	28~32	19~23	18.1~22.1	23~27	65°C	45°C	105°C	75°C
48 V	60.1	56~60	38~46	36.1~44.1	46~54				

5. Front LCD Panel – Display & Setup

5-1. LCD Panel Indications

5-1-1. Set the Power Switch to the "ON" position. THE, inverter starts working normally. The inverter will be operating in normal condition when either of the following messages are displayed on the LCD screen:

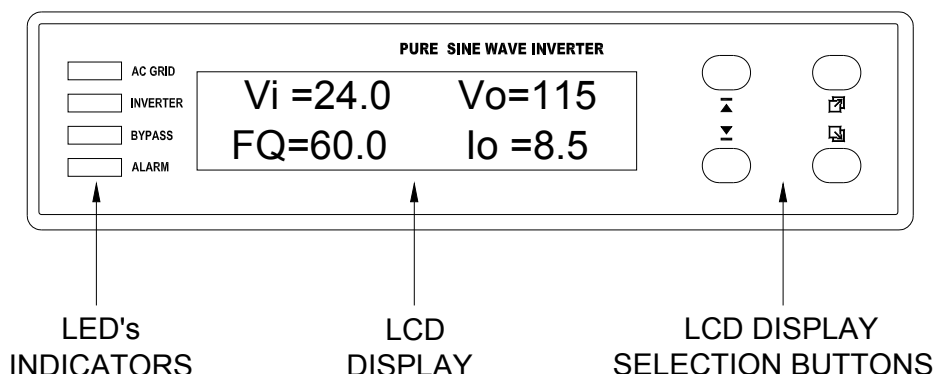

5-1-2. LED Indications:

- **AC GRID:** Displays AC input status.

AC Input	LED Status
AC input and DC-AC Inverter Output are Synchronous	Green
AC input ON	Orange
AC input OFF	Off

Note. Synchronous means that the: grid AC input frequency and DC-AC inverter output frequency or phase are the same (See details in

Section 5-3-3).

■ **INVERTER:** Displays DC-AC inverter status.

DC-AC Inverter	LED Status
Power OK	Green
Power Not Good	Red

■ **BYPASS:** Displays Bypass relay status.

Bypass	LED Status	AC Output (Load)
From DC-AC inverter (On-line Mode)	Orange	AC Input
	Off	DC-AC Inverter
From AC input bypass (Off-line Mode)	Green	AC Input
	Off	DC-AC Inverter

■ **ALARM:** Displays status of the Failure Alarm.

Alarm	LED Status
Over/Under Alarm /FAN Alarm	Orange
Set alarm in the inverter to operate normally	Off

NOTE. For instructions on setting the alarm, see details in Section 5-3.

5-1-3. LCD Display Selection Buttons:

■ Function of Various Keys :



Function <Up>: You can use the “up” button to scroll through the menus. or to select the value for set up under setting mode.



Function <Down>: You can use the “Down” button to scroll through the

menus or to select the value for set up under setting mode. .



Function <Page Up>: You can use the “Page Up” button to scroll through the menus.



Function <Page Down>: You can use the “Page Down” button to scroll through the menus.

Function <Enter Setup Menu>: Press the button longer than 2 seconds, The inverter will change to “Setup Menu Mode” which appears on the LCD screen for the user to set functions.

Function <Enter>: Confirms a selection or value.

5-1-4. LCD Display: Displays inverter’s operational status.

5-2. Startup Sequence and Standby Status

5-2-1. Once turn on the inverter. The display shows “SR-1000 INVERTER INITIALIATION..”, then checks the inverter.

Status flow is as follows:

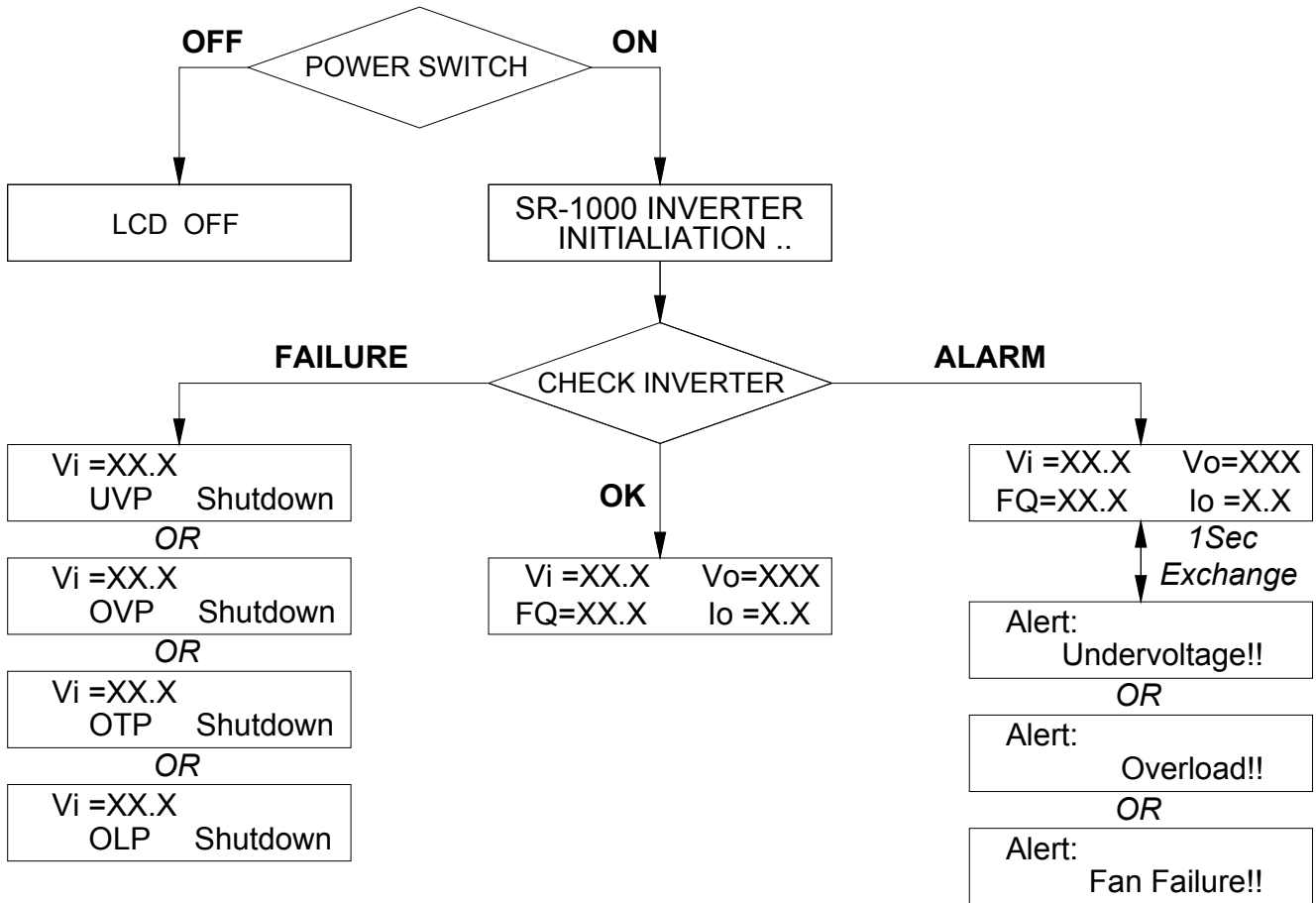

5-3. Setup Menu – Operation and Instructions

Entering Setup Menu:

Press  Button longer than 2 seconds. The inverter, enters the Setup Menus consisting of three layers:

- (1)Select Menu Heading: (2)Select Menu Item: (3)Setting Value:

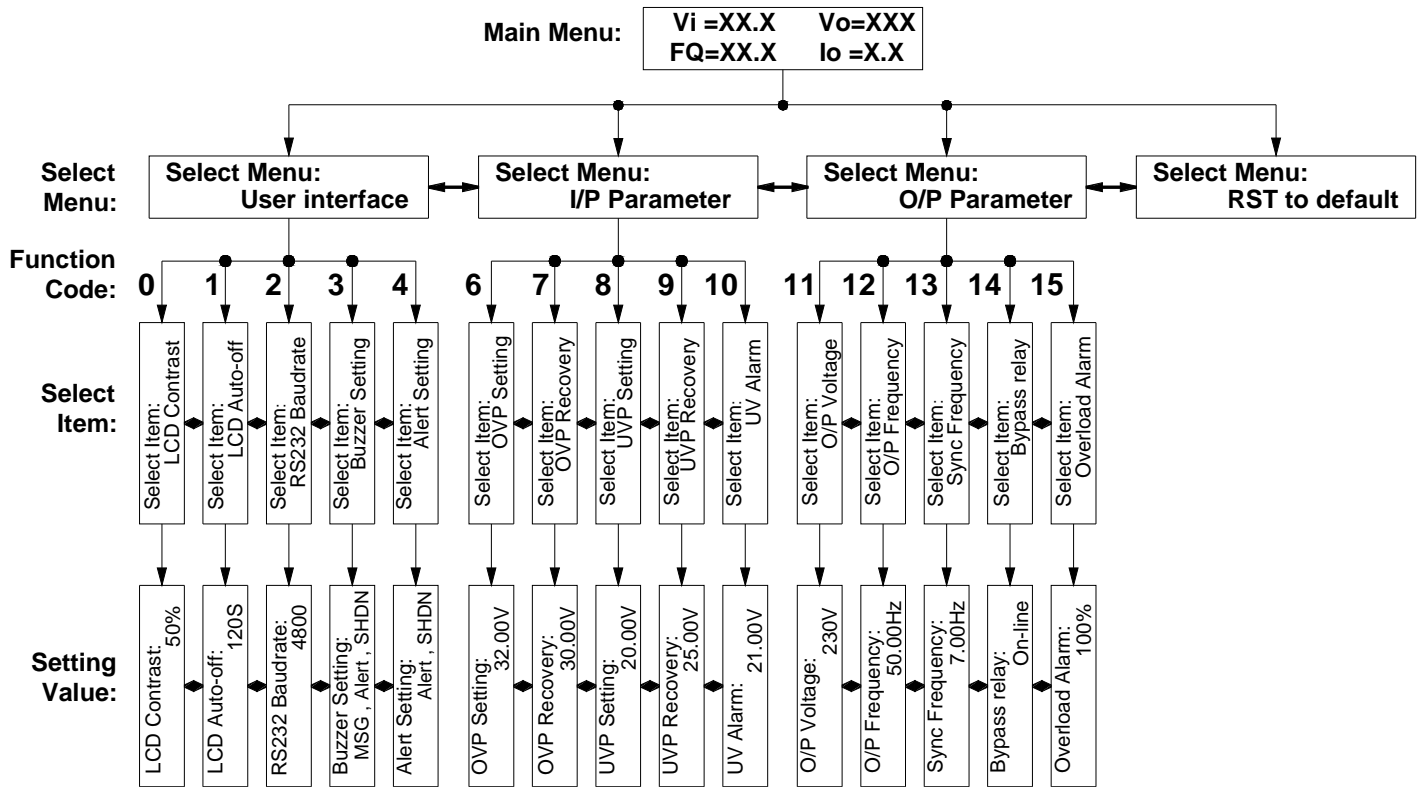

5-3-1. User interface (Select Menu):

0). **LCD Contrast:** Sets LCD screen contrast.

Default=50%

Setting Range= 0%~100%

1). **LCD Auto-off:** Sets LCD auto off timer.

Default=120 seconds.

Setting Range= Disable~250 seconds.

2). **RS232 Baud-rate:** Sets standard RS-232 Baud-rate.

Default=4800

Setting Range= 1200/2400/4800/9600

3). **Buzzer Setting:** Sets the internal buzzer sound ON/OFF.

When setting, the LCD screen display,

Buzzer “ON”, Buzzer “OFF”.

Default=MSG, Alert, SHDN

Setting Range= Disable / Shutdown / Alert

/ Alert, SHDN / Message

/ Message, SHDN / Message, Alert

/ MSG, Alert, SHDN

Menu	Status	Buzzer
Message	Power ON or Push Keypad	ON
Alert	FAN Fail or UV Alarm or Overload Alarm	ON
Shutdown	OVP or UVP or OLP or OTP	ON
Disable	Any	OFF

- 4). **Alert Setup:** When alert occurs, the internal Dry Contact Relay will open / close. (See details in Section 3-1-6)
 Default= Alert, SHDN
 Setting Range= Disable / Shutdown / Alert / Alert, SHDN

Menu	Status	Relay
Alert	FAN Fail or UV Alarm or Overload Alarm	ON
Shutdown	OVP or UVP or OLP or OTP	ON
Disable	Any	OFF

5-3-2. I/P Parameter (Select Menu):

- 6). **OVP Setting:** Sets the Over Voltage Protection (OVP) and shutdown.
 Default= 34 VDC for 24 V Model, 60 VDC for 48 V Model

Model	Setting Value Range
24 V	30 VDC ~ 34 VDC
48 V	60 VDC MAX.

- 7). **OVP Recovery:** When the DC input voltage is higher than the OVP setting, the inverter shuts-down; Once the input voltage falls below the set OVP value, the inverter will automatically restart.
 Default= 30 VDC for 24 V Model, 56VDC for 48 V Model

Model	Setting Value Range
24 V	28 VDC ~ 32 VDC
48 V	56 VDC ~ 60 VDC

- 8). **UVP Setting:** Setting the inverter’s Under Voltage Protection (UVP) and Shutdown.
 Default= 18 VDC for 24 V Model, 36 VDC for 48 V Model

Model	Setting Value Range
24 V	18 VDC ~ 22 VDC
48 V	36 VDC ~ 44 VDC

- 9). **UVP Recovery:** When the DC input voltage is below the set UVP value the inverter shuts-down; Once the input voltage rises above the set UVP value, the inverter will automatically restart.
 Default= 25 VDC for 24 V Model, 50 VDC for 48 V Model

Model	Setting Value Range
24 V	23 VDC ~ 27 VDC
48 V	46 VDC ~ 54 VDC

- 10). **UV Alarm:** Sets Under Voltage (UV) alarm. When the input voltage is lower than the set value, the unit will sound “beep” to remind that the unit is going to shutdown. At the meantime, the contact in the internal Dry Contact Relay will open / close (See details in Section 3-1-6).

Default= 21 VDC for 24 V Model, 42 VDC for 48 V Model

Model	Setting Value Range
24 V	19 VDC ~ 23 VDC
48 V	38 VDC ~ 46 VDC

NOTE. The value of voltage set for the “UV Alarm” should be equal to or higher than the value set for “UVP” or else the unit will shutdown without any audible warning.

5-3-3. O/P Parameters:

- 11). **O/P Voltage:** Set the inverter output voltage.

Default= 110 VAC for 110 V Model, 230 VAC for 220 V Model

Model	Setting Value Range
110 V	97 VAC ~ 123 VAC
220 V	194 VAC ~ 246 VAC

- 12). **O/P Frequency:** Set the inverter output frequency.

Default= 60 Hz for 110 V Model, 50 Hz for 220 V Model.

Model	Setting Value Range
110 V	47 Hz ~ 63 Hz
220 V	47 Hz ~ 63 Hz

- 13). **Sync Frequency:** Sets the AC output synchronous frequency.

Example: AC input= 230 VAC / 50Hz, User setting Value= 7Hz

When the DC to AC inverter “Frequency” is within The Range of 43 Hz~57 Hz, the internal bypass relay will operate normally. When the “Frequency” is less than 43 Hz or more than 58 Hz, the internal bypass relay will de-energize.

(See details in Section 2-2)

Default= 0.1Hz ~ 7Hz.

Model	Setting Value Range
110 V	0.1 Hz ~ 7 Hz
230 V	0.1 Hz ~ 7 Hz

14). Bypass Relay: The setup is provided in one of the following two ways:
 On line Mode or Off line Mode (Exacting, Normal, Haphazard).
 Default= Normal (Off line).

Mode	Menu	Bypass Relay Switching Feature
OFF LINE (See details in Section 5-3)	Exacting	The bypass relay will switch "ON" or "OFF" based on conformance to, the Phase and Sync Frequency window that has been set (Function Code 13)
	Normal	The bypass relay will be "ON" if AC input (Grid) power is available. The DC-AC inverter will remain synchronized and Phase with the incoming AC power (Grid). The relay will NOT switch off if the grid frequency is beyond the range set under Sync Frequency window (Function Code 13).
	Haphazard	The bypass relay will switch "ON" or "OFF". Conformance to, phase and frequency synchronization will not be considered.
ON LINE	-----	(See details in Section 5-3)

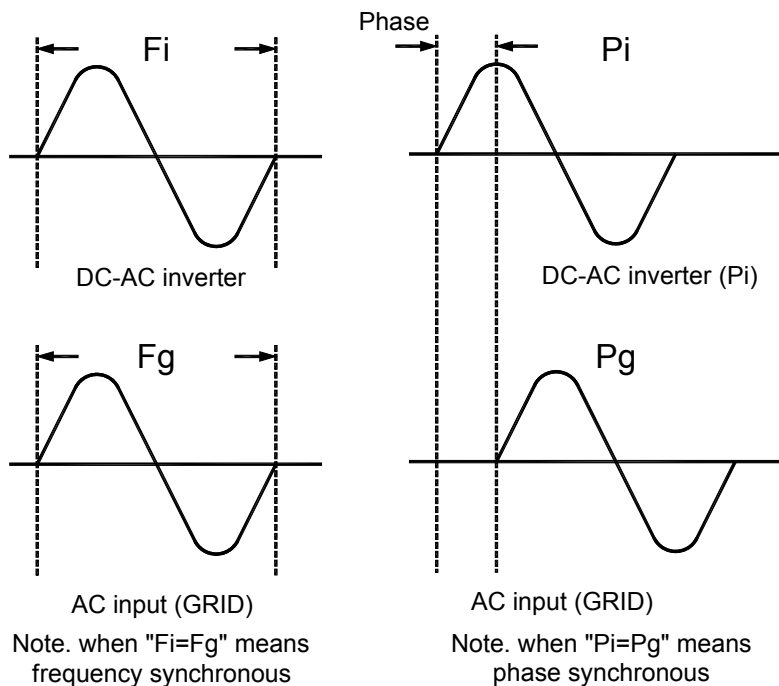

- 15). Overload Alarm:** Sets the overload alarm. When the output power is higher than the set value, the unit will sound “beep” to remind that the unit is going to shutdown. At the same time, the internal Dry Contact Relay will open/close (See details in Section 3-1-6).
 Default= 100%
 Setting range= 50%~110%

6. RS-232 Communication and Operation

6-1. Operation of RS-232 Serial Port:

6-1-1. This unit uses a standard 9-Pole D connector and three of the RS232 signal lines:

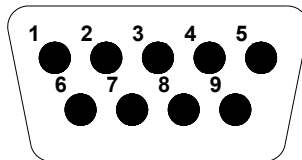

Signal description	PIN
N.C	1
RXD	2
TXD	3
DTR	4
GND	5
DSR	6
RTS	7
CTS	8
N.C	9

6-1-2. The connection between this unit and the computer is as follows:

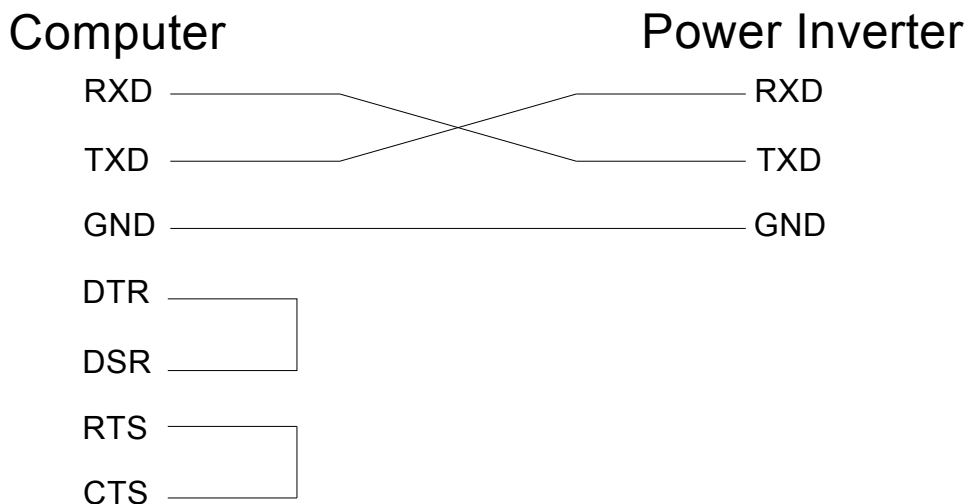

6-1-3. The RS232 interface of this unit employs ASCII code to implement the asynchronous serial transmission control.

The byte structure is START-BIP – 8 BIT DATA-STOP BIT.

Baud rate: 1200/2400/4800/9600(See details in Section 5-3-1).

6-1-4. Coupled with PC software application port. Operation is as detailed in Section 6-2.

6-2. Interface Commands:

The buffer size used for the RS232 port is 12-byte. This unit will ignore all bytes more than this value. During transmission, this unit will indicate it is ready to receive data from computer by this DTR line. A computer has to check the DTR line before sending any information to this unit. This unit is normally always ready to receive data while operating. When a LF character (ASCII code 0AH) is received, this unit would finish the receiving by clearing the DTR status and begin to interpret the received information. The unit would execute the received command (AND/OR data) if it is correct. Irrespective of whether the command is accepted or not, the unit will always send back a response signal to the computer and set DTR to ready for receiving more incoming information.

6-2-1. The Baud-rate of the RS232 interface can be set with the help of the Setup Menu (See details in Section 5-3-1).

Note. You have to reset the unit after adjustment to activate the new setting.

6-3. Example of the RS232 Operation:

6-3-1. RS232 command:

Command format:

This unit uses high-level language commands with a CR (0DH) and LF (0AH) as the end of the command.

The system would interpret and execute the command only after these two characters are received. After the unit execute the command, it would send a response string to the computer. The response string is as follows:

= > CR LF: Command executed successfully

? > CR LF: Command error, not accepted

! > CR LF: Command correct but execution error (e.g. parameters out of range).

If the command needs any information from the unit, the unit would send the information back to the computer (with CR and LF) and then send the response string to the computer.

6-3-2. Command format:

This unit supports the following command format.

There should always be a CR (0DH) and a LF (0AH) appended to the command while sending the command to this unit.

1). Command to switch the Power ON/OFF:

Format: Power <value>

Example: A space (ASCII code 20H) is needed between Power and <value>.

<value> can be one of the following.

“0”: Power off

“1”: Power on

2). Command to query the Output Frequency:

Format: FRQ?

After “Enter”, the unit’s “Output Frequency” appears on the PC screen.

3). Command to query the Output Voltage:

Format: VOL?

After “Enter”, the unit’s “Output Voltage” appears on the PC screen.

4). Command to query the Output Current:

Format: AMP?

After “Enter”, the unit’s “Output Current” appears on the PC screen.

5). Command to query the Input Battery Voltage:

Format: BAT?

After “Enter”, the unit’s “Input Voltage” appears on the PC screen.

6-3-3. Command for accessing Setup Menus and adjusting values:**1). Select the Setup Menus with the help of Function Codes:**

Format: FUNC <Function Code>

After “Enter”, the Setup Menu for the Function Code will be called.

The <Function Code>= 0~17, as follows:

<Function Code>	Setting Menu	<Function Code>	Setting Menus
0	LCD Contrast	9	UVP Recovery
1	LCD Auto-off	10	UV Alarm
2	RS232 Baud-rate	11	O/P Voltage
3	Buzzer Setting	12	O/P Frequency
4	Alert Setting	13	Sync Frequency
5	NOT USED	14	Bypass Relay
6	OVP Setting	15	Overload Alarm
7	OVP Recovery	16	NOT USED
8	UVP Setting	17	NOT USED

- 2). Command to query the Functions No:
 Format: FUNC?
 After “Enter”, the unit’s “Function Code” appears on the PC screen.

- 3). Command to query the set value of the Function:
 Format: SETT?
 After “Enter”, the existing set value of the function appears on the PC screen.

- 4). Command to set or adjust the value of the Function:
 Format: SETT <value>
 After “Enter”, the new value of the Function is set Choose the <value> of the function as follows:

FUNC 0: LCD Contrast

Setting Menu	SETT <value>
LCD Contrast	0~100

FUNC 1: LCD Auto-off

Setting Menu	SETT <value>
LCD Auto-off	Disable~250

FUNC 2: RS232 Baud rate

Setting Menu	SETT <value>	Baud rate
RS-232 Baud rate	0	1200
	1	2400
	2	4800
	3	9600

FUNC 3: Buzzer Setting

Setting Menu	SETT <value>	Buzzer (Beep sound)
Buzzer Setting	0	Disable
	1	Shutdown
	2	Alert
	3	Alert , SHDN
	4	Message
	5	Message , SHDN
	6	Message , Alert
	7	Msg , Alert , SHDN

FUNC 4: Alert Setting

Setting Menu	SETT <value>	Alert
Alert Setting	0	Disable
	1	Shutdown
	2	Alert
	3	Alert , SHDW

FUNC 6: OVP Setting

Setting Menu	SETT <value>	Model
OVP Setting	30~34	SR1000-124
		SR1000-224
	60 MAX.	SR1000-148
		SR1000-248

FUNC 7: OVP Recovery

Setting Menu	SETT <value>	Model
OVP Recovery	28~32	SR1000-124
		SR1000-224
	56~60	SR1000-148
		SR1000-248

FUNC 8: UVP Setting

Setting Menu	SETT <value>	Model
UVP Setting	18~22	SR1000-124
		SR1000-224
	36~44	SR1000-148
		SR1000-248

FUNC 9: UVP Recovery

Setting Menu	SETT <value>	Model
UVP Recovery	23~27	SR1000-124
		SR1000-224
	46~54	SR1000-148
		SR1000-248

FUNC 10: UV Alarm

Setting Menu	SETT <value>	Model
UV Alert	19~23	SR1000-124
		SR1000-224
	38~46	SR1000-148
		SR1000-248

FUNC 11: O/P Voltage

Setting Menu	SETT <value>	Model
O/P Voltage	97~123	SR1000-124
		SR1000-148
	194~246	SR1000-224
		SR1000-248

FUNC 12: O/P Frequency

Setting Menu	SETT <value>
O/P Frequency	47~63

FUNC 13: Sync Frequency

Setting Menu	SETT <value>
Sync Frequency	0.1~7

FUNC 14: Bypass Relay

Setting Menu	SETT <value>	Mode
Bypass Relay	0	ON LINE
	1	Haphazard(OFF LINE)
	2	Normal(OFF LINE)
	3	Exacting(OFF LINE)

FUNC 15: Overload Alarm

Setting Menu	SETT <value>
Overload Alarm	50~110

7. Information

7-1. Troubleshooting



WARNING:

Do not open or disassemble the SR series Inverter. Attempting to service the unit may cause risk of electrical shock or fire.

Problems and Symptoms	Possible Cause	Solutions
<i>No AC Power "Output"</i>		
a. LCD Panel Display "OLP Shutdown"	Short circuit , wiring error. over loading.	Check AC wiring for short circuit . Reduce load.
b. LCD Panel Display "OVP Shutdown"	Over input voltage (OVP)	Check input voltage Reduce input voltage
c. LCD Panel Display "UVP Shutdown"	Low input voltage. (UVP)	Recharge battery. Check connections and cables.
d. LCD Panel Display "OTP shutdown"	Thermal shutdown. (OTP)	Improve ventilation. Make sure ventilation, grilles / slots of the inverter are not obstructed. Lower ambient temperature.

7-2. Warranty

We guarantee this product against defects in materials and workmanship for a period of 36 months from the date of purchase and will repair or replace any defective power inverters if you directly returned them to us with postage paid.

Please note that Cotek is only responsible for ensuring our products are operational before delivering. This warranty will be considered void if the unit has been misused, altered, or accidentally damaged. Cotek is not liable for anything that occurs as a result of the user's fault.

8. Appendices



CERTIFICATE

Issued Date: Mar. 12, 2007
Report No.: 072H038-ITUSP01V02

This is to certify that the following designated product

Product : POWER INVERTER
Trade name : COTEK
Model Number : SR1000-124, SR1000-148
Company Name : COTEK ELECTRONIC IND. CO., LTD.

This product, which has been issued the test report listed as above in Quietek Laboratory, is based on a single evaluation of one sample and confirmed to comply with the requirements of the following EMC standard.

FCC CFR Title 47 Part 15 Subpart B: 2005 Class B, CISPR 22: 2005

TEST LABORATORY

A handwritten signature in blue ink that reads 'Arthur Liu'.

Arthur Liu / Deputy Manager



CERTIFICATE

Issued Date: Mar. 12, 2007
Report No.: 072H038-ITCEP07V02

This is to certify that the following designated product

Product : POWER INVERTER
Trade name : COTEK
Model Number : SR1000-224, SR1000-248
Company Name : COTEK ELECTRONIC IND. CO., LTD.

This product, which has been issued the test report listed as above in QuieTek Laboratory, is based on a single evaluation of one sample and confirmed to comply with the requirements of the following EMC standard.

EN 55022: 1998+A1: 2000+A2: 2003	EN 55024: 1998+A1: 2001+A2: 2003
EN 61000-3-2: 2006	IEC 61000-4-2 Edition 1.2: 2001-04
EN 61000-3-3: 1995 + A1: 2001	IEC 61000-4-3: 2002+A1: 2002
	IEC 61000-4-4: 2004
	IEC 61000-4-5 Edition 1.1: 2001-04
	IEC 61000-4-6 Edition 2.1: 2004-11
	IEC 61000-4-8 Edition 1.1: 2001-03
	IEC 61000-4-11 Second Edition: 2004-03

TEST LABORATORY

Arthur Liu

Arthur Liu / Deputy Manager

COTEK

No. 33, Rong Hsin Rd., Pa Teh City, Tao Yuan County, Taiwan

Phone : 886-3-3661581 FAX : 886-3-3676029

E-mail : sales@cotek.com.tw http : // www.cotek.com.tw

2011.04 A0