

QBASE (ITEM 2) AND POST (ITEM 4)

- 1 AVAILABLE IN 3.75", 5", 7", 9", AND 12" HEIGHTS
- 2 AVAILABLE IN MILL FINISH AND BRONZE ANODIZED FINISH
- 3 STAINLESS STEEL LAG SCREWS INCLUDED WITH ANODIZED FINISH

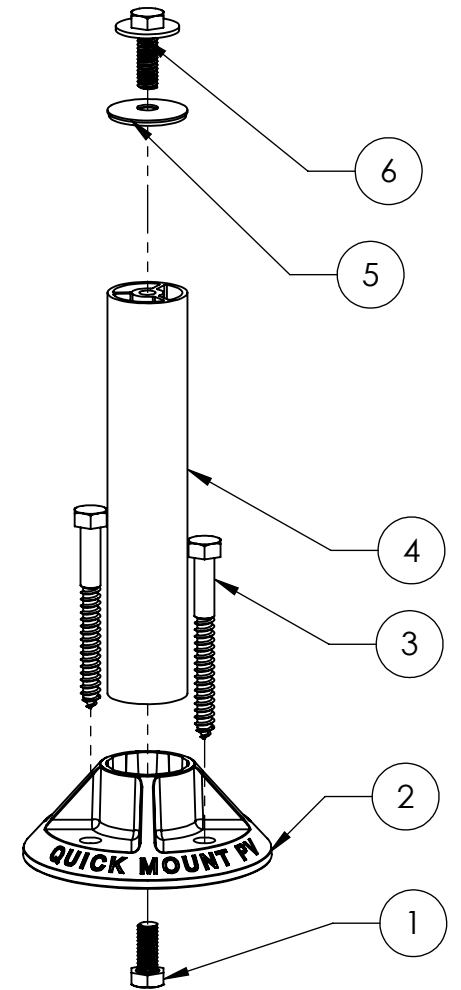

ITEM NO.	DESCRIPTION	QTY.
1	CAP SCREW, HEX HEAD, 5/16"-18 X 3/4" UNC-2A, GRADE 8, MAGNI	1
2	QBASE, 1-1/4" ID, FOR 5/16" HARDWARE, A360 CAST AL	1
3	LAG SCREW, HEX HEAD, 5/16" X 3", ZINC	2
4	POST, 1.25" OD X 6.5", 6063-T5/6063-T6, MILL	1
5	WASHER, SEALING, 5/16" ID X 1-1/4" OD, EPDM BONDED SS	1
6	CAP SCREW, HEX HEAD, 5/16"-18 X 1" UNC-2A, NYLON PATCH, W/ CAPTIVE WASHER, 1"OD, 18-8 SS	1

PROPRIETARY AND CONFIDENTIAL
 THE INFORMATION CONTAINED IN THIS DRAWING IS THE SOLE PROPERTY OF QUICK MOUNT PV. ANY REPRODUCTION IN PART OR AS A WHOLE WITHOUT THE WRITTEN PERMISSION OF QUICK MOUNT PV IS PROHIBITED. COPYRIGHT © 2019 QUICK MOUNT PV

DO NOT SCALE DRAWING

Quick Mount PV[®]

TITLE:
QMLSH: QBASE LOW SLOPE MOUNT

UNLESS OTHERWISE SPECIFIED: DIMENSIONS ARE IN INCHES TOLERANCES: FRACTIONAL ± 1/8 TWO PLACE DECIMAL ±.19 THREE PLACE DECIMAL ±.094	SIZE A	DRAWN BY: RAD	REV 10
	SCALE: 1:3	DATE: 8/9/2019	WEIGHT: 1.02
		SHEET 1 OF 1	