

CATALOG 2017

MOBILE LIVING MADE EASY.

CLIMATE, COOKING, AND SANITATION PRODUCTS
THAT MAKE YOU FEEL AT HOME.



 **DOMETIC**



CLIMATE

PAGE 3 – 54



FOOD & BEVERAGE

PAGE 55 – 84



HYGIENE & SANITATION

PAGE 86-105

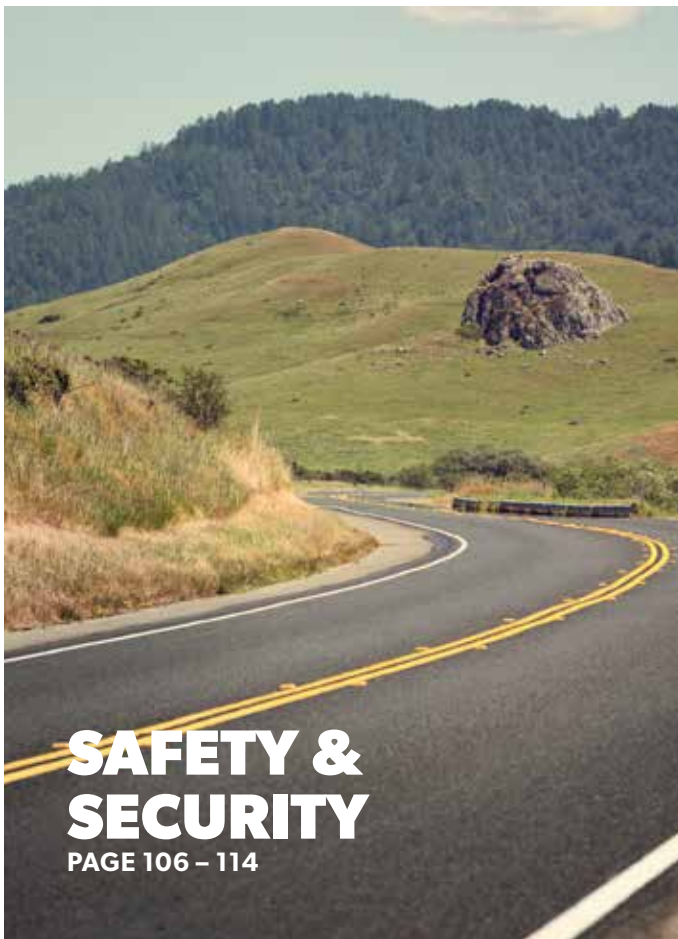

SAFETY & SECURITY

PAGE 106 – 114

CLIMATE

Air Conditioners	5–14
Awnings	15–42
Patio Rooms	43–46
Ventilation	47–50
Furnaces	51–54

FOOD & BEVERAGE

Refrigeration	57–72
Mobile Cooling	73–80
Cooking	81–84

HYGIENE & SANITATION

Sanitation	87–92
Cleaning	93–100
Water Heaters	101–104

SAFETY & SECURITY

Driving Support	107–110
Safety Solutions	111–113

DOMETIC ON THE WEB

Learn more about Dometic and our wide array of innovative products.

Before you head out, head to:

WWW.DOMETIC.COM

- / AIR CONDITIONERS**
- / AWNINGS**
- / PATIO ROOMS**
- / VENTILATION**
- / FURNACES**



CLIM

A scenic coastal landscape featuring a gravel path leading down a grassy hillside. A wooden fence runs along the path. In the background, a bay with blue water is visible, surrounded by green hills and a bright sky. Pine trees are in the foreground, framing the scene.

MATE



COMFORT BY DESIGN

AIR CONDITIONERS



BLIZZARD NXT

The Dometic Blizzard NXT air conditioner can be installed in height-restrictive spaces, making it ideal for flybridge, cockpit, engine room, or exterior deck installations. The air conditioner stands just 8 in/203 mm high. The dual blowers can be ducted to different areas or to confined areas such as flybridge dashboards and consoles. The unit features an oversized four-row evaporator coil for excellent heat removal under low fan-speed conditions. A highly efficient blower reduces power consumption, and the blower flows to two outlets.

- Attractive aerodynamic design
- Rugged and durable
- High-impact polypropylene injection-molded shroud and base pan

Cool Only

BLIZZARD NXT AIR CONDITIONERS

ORDER NUMBER

H540315	13,500 BTU Upper Unit (Requires an ADB Kit or Electronic Control Kit)
H540316	15,000 BTU Upper Unit (Requires an ADB Kit or Electronic Control Kit)
H541815	13,500 BTU Upper Unit Non-Ducted or Ducted Application. Comfort Control Center II Thermostat required.
H541915	13,500 BTU Upper Unit Non-Ducted or Ducted Application. CT Single Zone Thermostat required.
H541816	15,000 BTU Upper Unit Non-Ducted or Ducted Application. Comfort Control Center II Thermostat required.
H541916	15,000 BTU Upper Unit Non-Ducted. CT Single Zone Thermostat required.

Heat and Cool

BLIZZARD NXT HEAT PUMPS

ORDER NUMBER

H551816	15,000 BTU HP Heat Pump Non-Ducted or Ducted Application. Comfort Control Center II Thermostat required.
H551916	15,000 BTU HP Heat Pump Non-Ducted or Ducted Application. CT Single Zone Thermostat required.

CONTROL COMPONENTS

ORDER NUMBER

3314851.000	ADB - Manual Controls/No Heat Strip Option - Polar White
3312020.000	Comfort Control Center II Multi-Zone Kit
3314082.011	Comfort Control Center II - White
3314082.000	Comfort Control Center II - Black
3316230.000	CT Single Zone/ T-Stat Cool/Furnace - White
3316230.014	CT Single Zone/ T-Stat Cool/Furnace - Black
3316232.000	CT Single Zone/ T-Stat Cool/Furnace/Heat Strip - White
3316232.010	CT Single Zone/ T-Stat Cool/Furnace/Heat Strip - Black

RETURN AIR GRILLES FOR DUCTED SYSTEMS

ORDER NUMBER

3315930.010	Quick Cool Ducted Return Air Package - Polar White
-------------	--



Quick Cool Return Air Package



Air Distribution Box (ADB)



CT Single Zone Thermostat



Comfort Control Center II



PENGUIN II LOW PROFILE HEAT PUMPS

The Dometic Penguin II Heat Pump provides year-round heating and cooling of recreation vehicles and campers. With a low profile under 10 in/25.4 cm, the sleek shroud reduces wind resistance while the vehicle is underway. By using advanced composite materials and advanced design, Penguin II delivers better comfort more efficiently than many other similar models. For non-ducted applications, a Dometic Air Distribution Box is required (available separately).

- Low profile – under 10 in/25.4 cm high
- Sleek, contemporary shroud design
- Eco-friendly refrigerant heats more efficiently

PENGUIN II HEAT PUMPS (Available in Polar White or Black)

ORDER NUMBER

650015C	13,500 BTU Penguin II Low Profile Heat Pump - Non-ducted application only – ADB required.
651815C	13,500 BTU Penguin II Low Profile Heat Pump - Non-ducted or ducted application – CCCII Thermostat required.
651816C	High Capacity BTU Penguin II Low Profile Heat Pump - Non-ducted or ducted application – CCCII Thermostat required.
651916C	High Capacity BTU Penguin II Low Profile Heat Pump - Non-ducted or ducted application – CT Single Zone Thermostat required.



Quick Cool Return Air Package

ACCESSORIES FOR 650015C

ORDER NUMBER

3314853.000	Manual ADB - 650015C Penguin II Heat Pump
-------------	---



Air Distribution Box (ADB)

ACCESSORIES FOR 651815 & 651816

ORDER NUMBER

3100895.006	Qty 4 - 6 in. Bolts
3101538.001	Qty 6 - 9 in. Bolts
3314082.011	CCCII Thermostat - Polar White
3314082.000	CCCII Thermostat - Black
3314850.000	Universal ADB - Polar White - Wall Mount Thermostat
3315930.010	Quick Cool Ducted Return Air Package - Polar White



CT Single Zone Thermostat

ACCESSORIES FOR 651916

ORDER NUMBER

3100895.006	Qty 4 - 6 in. Bolts
3101538.001	Qty 6 - 9 in. Bolts
3316250.000	CT Single Zone Thermostat - Polar White
3316250.012	CT Single Zone Thermostat - Black
3314850.000	Universal ADB - Polar White - Wall Mount Thermostat
3315930.010	Quick Cool Ducted Return Air Package - Polar White



Comfort Control Center II

Notes:

Upper unit model and serial numbers located on bottom of base pan near return air opening.
Model and serial numbers on controls located on top of control box.



PENGUIN II LOW PROFILE AIR CONDITIONERS

The Dometic Penguin II Rooftop Air Conditioner features a futuristic look with powerful cooling performance. With a low profile under 10 in/25.4 cm, the sleek shroud reduces wind resistance while the vehicle is underway. A rib-reinforced base pan delivers lasting strength. The Penguin II is perfect for non-ducted cooling systems. Non-ducted application requires Air Distribution Box (ADB) (available separately).

- Low profile – under 10 in/25.4 cm high
- Sleek, contemporary shroud design reduces drag for improved mileage
- Perfect for ducted or non-ducted cooling systems

PENGUIN II LOW PROFILE AIR CONDITIONERS (Available in Polar White or Black)

ORDER NUMBER

640310C	High Efficiency Penguin II Low Profile Air Conditioner ADB or ducted application.
640315C	13,500 BTU Penguin II Low Profile Air Conditioner Non-ducted. ADB required.
641915C	13,500 BTU Penguin II Low Profile Air Conditioner Non-ducted or Ducted. CT Single Zone Thermostat required.
641935C	13,500 BTU Penguin II Low Profile Air Conditioner Non-ducted or ducted. CT Single Zone Thermostat required with heat strip.
641835C	13,500 BTU Penguin II Low Profile Air Conditioner Non-ducted or Ducted. Multi-Zone CCC II required. Preinstalled heat strip.
641815C	13,500 BTU Penguin II Low Profile Air Conditioner Non-ducted or Ducted. Multi-Zone CCC II required.
641816C	High Capacity Penguin II Low Profile Air Conditioner Non-ducted or Ducted. Multi-Zone CCC II required.
641916C	High Capacity Penguin II Low Profile Air Conditioner Non-ducted or ducted. CT Single Zone Thermostat required.

CEILING ADB ASSEMBLIES

ORDER NUMBER

3314851.000	ADB Manual Controls - Polar White for 640310/640315
3314850.000	ADB Wall Thermostat - Polar White

CONTROL COMPONENTS

ORDER NUMBER

3314082.011	CCCII Thermostat - Polar White
3314082.000	CCCII Thermostat - Black
3312020.000	Multi Zone CCCII Thermostat
3316230.000	CT Single Zone/ T-Stat Cool/Furnace - White
3316230.014	CT Single Zone/T-Stat Cool/Furnace - Black
3316232.000	CT Single Zone/ T-Stat Cool/Furnace/Heat Strip - White
3316232.010	CT Single Zone/T-Stat Cool/Furnace/Heat Strip - Black

RETURN AIR GRILLES FOR DUCTED SYSTEM

ORDER NUMBER

3315930.010	Quick Cool Ducted Return Air Package - Polar White
-------------	--

OTHER PENGUIN II ACCESSORIES

ORDER NUMBER

3100895.006	Qty 4 - 6 in. Bolts	3105584.001	18 in. Extension Cord
3101538.001	Qty 6 - 9 in. Bolts	3106486.008	Remote Sensor 20'
3107688.016	Drain Kit	3311883.000	Hard Start Kit

ORDER NUMBER



Quick Cool Return Air Package



Air Distribution Box (ADB)



CT Single Zone Thermostat



Comfort Control Center II



BRISK II HEAT PUMPS

The Dometic Brisk II Heat Pump provides year-round heating and cooling of recreation vehicles and campers. Stronger, lighter, smaller and more environmentally friendly than the previous version, the Brisk II rooftop unit features tighter specification tolerances to maximize air flow and performance. By using advanced composite materials, Brisk II delivers better comfort more efficiently than many other similar models. For ducted applications, a Multi-Zone Comfort Control Center II thermostat is required.

- High-performance design
- EPP foam housing
- Fits standard 14 in/35.5 cm roof vents

BRISK II HEAT PUMPS

ORDER NUMBER

B59146	15,000 BTU Brisk II Heat Pump – Non-ducted application only – ADB required.
B59196	15,000 BTU Brisk II Heat Pump – Non-ducted or ducted application. – CT Single Zone thermostat required.
B59186	15,000 BTU Brisk II Heat Pump – Non-ducted or ducted application. Multi-Zone CCCII thermostat required.

ACCESSORIES FOR B59146

ORDER NUMBER

3314852.000	Manual ADB for B59146 Brisk II Heat Pump - Polar White
-------------	--

ACCESSORIES FOR B59186

ORDER NUMBER

3312020.000	CCCII Multi Zone Kit
3314082.011	CCCII Thermostat - Polar White
3314082.000	CCCII Thermostat - Black
3314850.000	Universal ADB - Wall Mount Thermostat
3315930.010	Quick Cool Ducted Return Air Package - Polar White

ACCESSORIES FOR B59196

ORDER NUMBER

3316234.000	CT Single Zone Thermostat - Cool/Furnace/Heat Pump - Polar White
3316234.016	CT Single Zone Thermostat - Cool/Furnace/Heat Pump - Black
3314850.000	Universal ADB - Wall Mount Thermostat
3315930.010	Quick Cool Ducted Return Air Package - Polar White

OTHER BRISK ACCESSORIES

ORDER NUMBER

3315333.003	Universal ADB - Return Air Filter
3100895.006	Qty 4 - 6" Bolts
3101538.001	Qty 6 - 9" Bolts
3105584.001	18" Extension Cord
3100281P009	Air Filter
3310718.006	Gasket
3310727.015	Hard Start Kit



Quick Cool Return Air Package



Air Distribution Box (ADB)



CT Single Zone Thermostat



Comfort Control Center II



BRISK AIR II COOL ONLY

The Dometic Brisk II Rooftop Air Conditioner is the next generation of one of the most popular and imitated RV air conditioners. Stronger, lighter, smaller and more environmentally friendly than the previous version, the Brisk II features tighter specification tolerances and improved materials to maximize air flow and performance. Non-ducted application requires a ceiling-mounted air distribution box (ADB). Ducted installations are controlled with the CT Single Zone thermostat. (ADB and LCD thermostat are available separately).

- High-performance design
- EPP foam housing
- Custom-composite laminated shroud

BRISK AIR II MODELS

ORDER NUMBER

B59530	High Efficiency Brisk Air Non-Ducted or Ducted Application. ADB or T-Stat required.
B57915	13,500 BTU Brisk Air Non-Ducted or Ducted Application. ADB or T-Stat required.
B59516	15,000 BTU Brisk Air Non-Ducted or Ducted Application. ADB or T-Stat required.

CEILING ADB ASSEMBLIES FOR B57915/B59516

ORDER NUMBER

3314851.000	ADB Kit with Manual Controls - Polar White
3314850.000	ADB requires Comfort Control Center II or CT Single Zone Thermostat

CEILING ADB ASSEMBLIES FOR B59530

ORDER NUMBER

3314854.000	ADB Kit with Manual Controls - Polar White
3314850.000	ADB - Requires Comfort Control Center II - Polar White

CONTROL COMPONENTS

ORDER NUMBER

3312020.000	Comfort Control Center II Multi-Zone Kit
3314082.011	Comfort Control Center II - Polar White
3314082.000	Comfort Control Center II - Black
3316230.000	CT Single Zone/ T-Stat Cool/Furnace - White
3316230.014	CT Single Zone/ T-Stat Cool/Furnace - Black
3316232.000	CT Single Zone/ T-Stat Cool/Furnace/Heat Strip - White
3316232.010	CT Single Zone/ T-Stat Cool/Furnace/Heat Strip - Black
3314998.000	Non-ducted Heat Strip
3315450.000	Ducted Heat Strip

ACCESSORIES

ORDER NUMBER

3106486.008	Remote Sensor - 20 ft.
3313107.064	Sensor Cap - White
3313107.066	Sensor Cap - Black

OTHER BRISK ACCESSORIES

ORDER NUMBER

3315333.003	Universal ADB - Return Air Filter
3100895.006	Qty 4 - 6" Bolts
3101538.001	Qty 6 - 9" Bolts
3105584.001	18" Extension Cord
3100281P009	Air Filter
3310718.006	Gasket
3310727.015	Hard Start Kit



Quick Cool Return Air Package



Air Distribution Box (ADB)



CT Single Zone Thermostat



Comfort Control Center II



COMMERCIAL GRADE AIR CONDITIONERS

Dometic Commercial Grade rooftop air conditioners are performance-tested to overcome harsh and unusual road and weather conditions. Many standard units break down after just four hours of extreme vibration testing, while the Dometic Commercial Grade is still going strong at 30 hours and more.

- Rugged and strong, yet lightweight
- Galvanized steel top plate for lasting strength
- Motor, compressor and evaporator are bracketed together for vibration-free operation
- Dual rubber bushings at top and bottom control noise and vibration
- Powder-coated base pan is 15 % thicker than other models
- Long copper lines are designed for minimal vibration
- Eco-friendly 410A refrigerant

Cool Only

ORDER NUMBER

477915	13,500 BTU - White or Black
479516	15,000 BTU - White or Black

CEILING ADB ASSEMBLIES

ORDER NUMBER

3314851.000	ADB Kit with Manual Control - Polar White
-------------	---



COOL CAT HEAT PUMP

The Dometic Cool Cat provides heating and cooling in small spaces. The compact size allows it to be installed in a variety of places without taking up a lot of space.

- 10,500 BTU cooling capacity
- Efficient heating to 30°F ambient temperature controlled by an LCD soft touch thermostat
- Under bunk/counter installation maximizes interior space options
- Lightweight, robust construction with simple installation
- Easy access, washable micro-weave air filter
- Slinger fan system increases the condenser efficiency

ORDER NUMBER

441003	10,150 BTU Heat Pump Non-ducted Application -CT Single Zone Thermostat required
--------	---

ACCESSORIES

ORDER NUMBER

3314087.069	Installation Kit, Thermostat included
3316250.000	CT Single Zone Thermostat -Polar White
3316250.012	CT Single Zone Thermostat - Black

ORDER NUMBER

3313107.126	Grill Filter Kit
3313107.092	Vented Grill Kit
3311170.000	Outside Grill Kit



CT Single Zone Thermostat



REPLACEMENT UPPER UNIT SHROUDS

FOR STANDARD AND HIGH EFFICIENCY A/C'S PREVIOUS MODELS: BRISK & PENGUIN REPLACEMENT SHROUDS

ORDER NUMBER

3309364.002	For Brisk model 7,100 BTU - Polar White
3309518.003	For Brisk models - Polar White With Gray Band
3309364.002	For Brisk models - Polar White
3309364.010	For Brisk models - Black
3308046.014	For Penguin models - Polar White
3308046.030	For Penguin models - Black

BRISK II & PENGUIN II REPLACEMENT SHROUDS

3315332.000	Brisk II - Polar White
3315332.001	Brisk II - Black
3314471.001	Penguin II - Polar White
3314471.003	Penguin II - Black

HP REPLACEMENT SHROUDS

3310710.003	Polar White
3311996.007	Black

BLIZZARD NXT REPLACEMENT SHROUDS

3316311.000	Polar White
3316311.012	Black

*If unsure which shroud replacement fits your current AC model, contact our FDD specialists

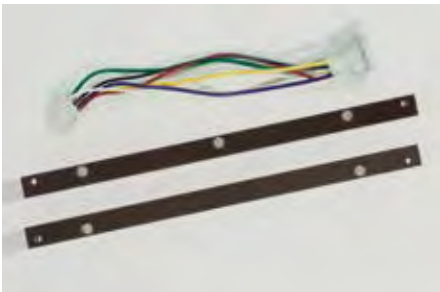

AIR CONDITIONER CONVERSION KITS

- Easily convert air conditioning units from Carrier and Coleman to Brisk Air or Penguin II*

ORDER NUMBER

3314534.000	Carrier to Brisk Air / Brisk II
3314534.011	Carrier to Penguin II
3314537.000	Coleman to Brisk Air / Brisk II
3314537.014	Coleman to Penguin II

*Not for use with heat pump models.

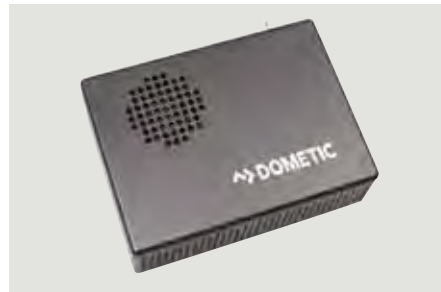

BREATHE EASY™ AIR PURIFIER

- Deodorize and clean air in your RV
- Reduce pollen, mold spores, viruses, bacteria, VOCs and odors
- Portable
- Lightweight
- AC/DC
- Purifies 800 cubic feet of air
- 6.25" x 4.5" x 1.75"

ORDER NUMBER

4210805	Portable, Breathe Easy Single Pack
4210804	Replacement Bulb

COMMON PARTS

The following is a list of the most frequently ordered air conditioner parts. Your FDD specialist can assist you to determine the optimum quantities you may want to stock.

ORDER NUMBER

3310718.006	14" x 14" Mounting Gasket
3313107.000	Thermostat - Manual ADB
3107206.017	
3104928.019	Return Grill - Ducted Quick Cool - Polar White
3310727.007	Motor Starter Kit - Brisk Air Only
3313107.034	Return Grill - Non-ducted ADB
3107206.017	- Polar White
3313107.015	Fan Blade - Brisk Air Only
3108015.003	Return Air Filter - Universal for Old Style ADB
3315333.002	Return Grill - Universal ADB - Polar White
3315333.003	Return Air Filter - Universal ADB
3312161.015	Thermostat - Universal Manual ADB -3314851.000
3310709.005	Fan Blade - Brisk II Air Only
3109492.003	Ducted Ceiling Vent



AIR COMMAND DUCTED SYSTEM

Ducted systems include wall mount thermostat and remote control. Fits most standard 14'x14' roof cutouts making Air Command an easy upgrade. Features an option to focus an arctic blast of air from the ceiling assembly after a long day in the sun. 2 year warranty.

ORDER NUMBER

15027	AC Ducted Roof Unit, 16K BTU Equivalent, White
15032	AC Ducted Roof Unit, 16K BTU Equivalent, Black
15028	AC Ducted Roof Unit, 18K BTU Equivalent, with Heat Pump, White
15033	AC Ducted Roof Unit, 18K BTU Equivalent, with Heat Pump, Black
15022	Ducted Indoor Plenum with Remote, White*

* Must have Plenum for initial installation

AIR COMMAND NON-DUCTED SYSTEM

Separate condenser fan and blower fan motors provide an ultra quiet experience and lower amp draw. Non-ducted systems include flip down thermostat and remote control. Fits most standard 14'x14' roof cutouts making Air Command an easy upgrade. 2 year warranty.

ORDER NUMBER

15025	AC Non-Ducted Roof Unit, 16K BTU Equivalent, White
15030	AC Non-Ducted Roof Unit, 16K BTU Equivalent, Black
15026	AC Non-Ducted, 18K BTU Equivalent, with Heat Pump, White
15031	AC Non-Ducted, 18K BTU Equivalent, with Heat Pump, Black
15021	Non-Ducted Indoor Plenum with Remote, White*

* Must have Plenum for initial installation

REPLACEMENT PART NUMBERS

ORDER NUMBER

15024	Molex Universal A/C Installation Elect Conns (2/pkg.)
15023	AC Remote Control Non-ducted
15029	AC Wall Thermostat White
15034	AC Top Shroud Black
15050	Top Shroud, White
15051	Top Shroud, Black
15054	Condenser Fan Motor
15055	AC Evaporator Fan Motor

ORDER NUMBER

15056	AC Condenser Fan
15057	AC Evaporator Fan Blade
15062	AC Rechi Run Capacitor 13.5/15K
15064	AC LG Run Capacitor 15K
15066	Inside Filters (for non-ducted units replacement)
15070	AC Install Kit Hold Down Clamps
15089	Adapter Kit (Ducted)
15086	Bolt Package for Thick Ceilings

DOMETIC AIR CONDITIONERS

	MODEL NUMBER	BTU RATING*	ELECTRICAL RATING	COMPRESSOR RATED LOAD AMPS	FAN MOTOR RATED LOAD AMPS	AC CIRCUIT PROTECTION	UPPER UNIT WEIGHT, LBS.	THERMOSTATS**
ROOFTOP AIR CONDITIONERS								
Penguin II	640310C	High	120VAC/60Hz/1PH	10.5	3.5	20 Amp	99	ADB or Thermostat
		Efficiency						
Penguin II	640315C	13,500	120VAC/60Hz/1PH	12.5	3.6	20 Amp	99	ADB or Thermostat
Penguin II	641915C	13,500	120VAC/60Hz/1PH	12.5	3.5	20 Amp	99	CT Single Zone
Penguin II	641935C	13,500	120VAC/60Hz/1PH	12.5	3.5	20 Amp	99	CT Single Zone
Penguin II	641916C	High	120VAC/60Hz/1PH	12.3	3.3	20 Amp	110	CT Single Zone
		Capacity						
Penguin II	641835C	13,500	120VAC/60Hz/1PH	12.5	3.5	20 Amp	99	CCC II
Penguin II	641815C	13,500	120VAC/60Hz/1PH	12.5	3.5	20 Amp	99	CCC II
Penguin II	641816C	High	120VAC/60Hz/1PH	12.3	3.3	20 Amp	110	CCC II
		Capacity						
Blizzard NXT	H540315	13,500	120VAC/60Hz/1PH	12.7	2.8	20 Amp	96	ADB or Thermostat
Blizzard NXT	H540316	15,000	120VAC/60Hz/1PH	13.2	2.8	20 Amp	99	ADB or Thermostat
Blizzard NXT	H541815	13,500	120VAC/60Hz/1PH	12.7	2.8	20 Amp	96	CCC II
Blizzard NXT	H541816	15,000	120VAC/60Hz/1PH	13.2	2.8	20 Amp	99	CCC II
Blizzard NXT	H541915	13,500	120VAC/60Hz/1PH	12.7	2.8	20 Amp	96	CT Single Zone
Blizzard NXT	H541916	15,000	120VAC/60Hz/1PH	13.2	2.8	20 Amp	99	CT Single Zone
Brisk Air	B59530	High	120VAC/60Hz/1PH	8.6	2.5	15 Amp	87	ADB or Thermostat
		Efficiency						
Brisk Air II	B57915	13,500	120VAC/60Hz/1PH	12.4	2.5	20 Amp	72	ADB or Thermostat
Brisk Air II	B59516	15,000	120VAC/60Hz/1PH	13.3	2.0	20	Amp 74	ADB or Thermostat
COMMERCIAL GRADE AIR CONDITIONERS								
Commercial	477915	13,500	120VAC/60Hz/1PH	12.4	2.5	20 Amp	91	ADB
Commercial	479516	15,000	120VAC/60Hz/1PH	13.3	2.0	20 Amp	103	ADB
HEAT PUMPS								
Penguin II	650015C	13,500	120VAC/60Hz/1PH	12.5	3.5	20 Amp	99	ADB
Penguin II	651815C	13,500	120VAC/60Hz/1PH	12.5	3.5	20 Amp	99	Multi-Zone CCC II
Penguin II	651816C	High	120VAC/60Hz/1PH	12.3	3.3	20 Amp	99	Multi-Zone CCC II
		Capacity						
Penguin II	651916C	High	120VAC/60Hz/1PH	12.3	3.3	20 Amp	99	CT Single Zone
		Capacity						
Brisk Air II	B59146	15,000	120VAC/60Hz/1PH	13.3	2.0	20 Amp	100	ADB
Brisk Air II	B59196	15,000	120VAC/60Hz/1PH	13.3	2.0	20 Amp	100	CT Single Zone
Brisk Air II	B59186	15,000	120VAC/60Hz/1PH	13.3	2.0	20 Amp	100	Multi-Zone CCC II
Blizzard NXT	H551816	15,000	120VAC/60Hz/1PH	13.2	2.8	20 Amp	100	CCC II
Blizzard NXT	H551916	15,000	120VAC/60Hz/1PH	13.2	2.8	20 Amp	100	CT Single Zone
Cool Cat	441003	10,150	120VAC/60Hz/1PH	8.9	2.2	20 Amp	70	CT Single Zone

* Nominal Capacity

**Thermostats: Additional control kits for thermostats may be required.

Note: Include suffix of Heat Pump or Air Conditioner model number (.xxx) being replaced when ordering a replacement unit.



WE KNOW SHADE

DOMETIC AWNINGS

SELECTION GUIDE

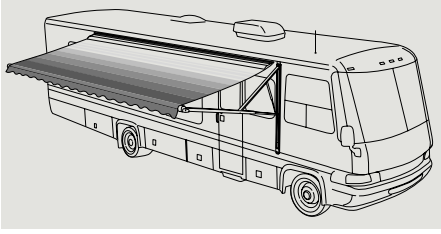

WEATHERPRO

Metal Weathershield Only
Monochromatic

Woven acrylic or Fade vinyl fabric

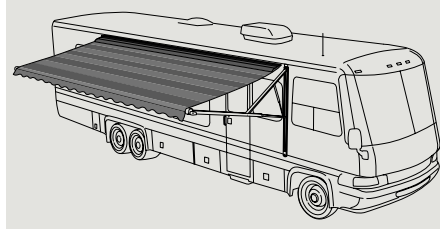

9100 AWNING

Metal or Vinyl Weathershield
Acrylic with Metal Weathershield**
Power or Manual

Woven acrylic or Fade vinyl fabric

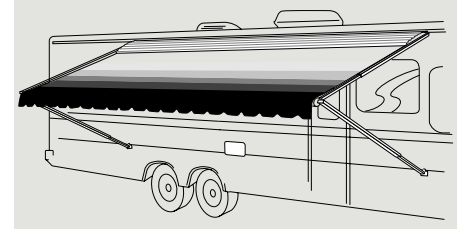

9000™ **

Metal Weathershield Only

Woven acrylic fabric only

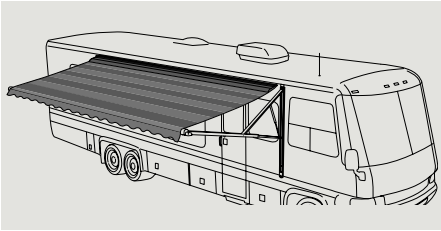

9100 POWERCHANNEL

Metal or Vinyl Weathershield
Acrylic with Metal Weathershield**
Power or Manual

Woven acrylic or Fade vinyl fabric

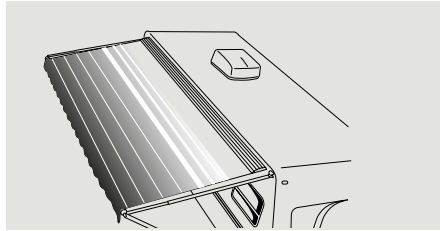

8500® **

Metal or Vinyl Weathershield

Fade vinyl fabric only

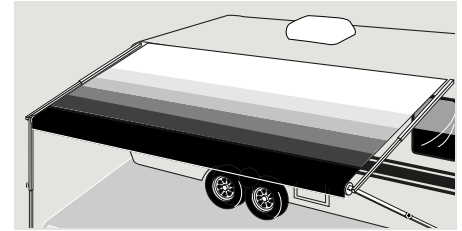

SUNCHASER® **

Vinyl Weathershield Only

Summer Shade vinyl fabric only*

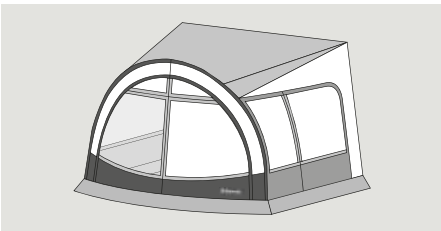

CABANA

Dome Awning

White with green trim

Waterproof Decron polyester



TRIM LINE®

Bag Case

Fade vinyl fabric only*



9500

Case

Power or Manual

Fade Vinyl fabric

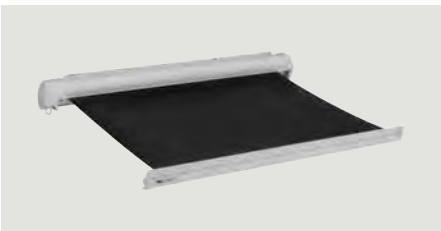

OASIS

Door Awning

Polar White Vinyl or Woven Acrylic

Power or Manual

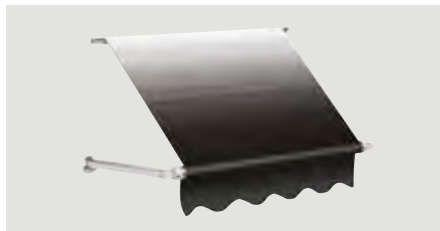

DELUXE OR ELITE

Window Awning

Acrylic with Metal Weathershield

Vinyl Fade with Metal Weathershield

Polar White Vinyl Weathershield



DELUXE SLIDETOPPER™

ELITE SLIDETOPPER™

SLIDETOPPER™ FULLCOVER

Slideout Cover

* Color pattern on top, Polar White underneath. ** Monochromatic



WEATHERPRO AWNINGS

Automatic | Vinyl or Woven Acrylic

Designed to out-think the elements, the WeatherPro is the great-looking awning you've always wanted – with the ease and convenience of self-operation by remote control. The Wind Sensor's "smart technology" automatically closes the awning when it detects potentially dangerous wind conditions.

With just the touch of a button, from either the handy remote control or the switch mounted inside the coach, the WeatherPro extends and tensions the fabric. Another touch and it stows away, securely locked for travel.

- Solid-state sensor automatically closes awning after detecting sustained winds
- Wireless remote control operates patio and door awning individually
- Exclusive Knee Action Design™ allows the awning to flex in moderate wind to prevent damage
- Metal weathershield provides extra protection from elements, matches hardware finish
- Heavy-duty motor is fully contained in the roller tube, self-locks awning in travel position
- Unique spring-arm mechanism automatically releases accumulating rain water
- Fits all straight hardware applications



Single compact remote control can operate WeatherPro and your Dometic power door awning.



The wind sensor is located at the very edge of the roller tube for maximum accuracy.



Dometic's exclusive Gustguard allows you to customize wind sensor settings with a simple one-touch control.

WEATHERPRO AWNINGS

Patio | Automatic | Vinyl or Woven Acrylic

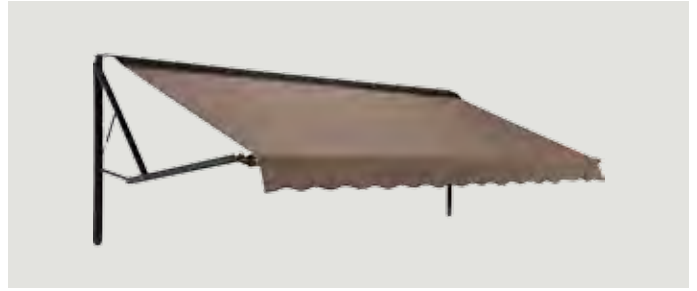

WOVEN ACRYLIC FABRIC

Shadow pattern, Metal weathershield

SIZE	FRTA	REPLACEMENT FABRICS*
12'	815[XX]12.000(X)	B3109893[XX].012
13'	815[XX]13.000(X)	B3109893[XX].013
14'	815[XX]14.000(X)	B3109893[XX].014
15'	815[XX]15.000(X)	B3109893[XX].015
16'	815[XX]16.000(X)	B3109893[XX].016
17'	815[XX]17.000(X)	B3109893[XX].017
18'	815[XX]18.000(X)	B3109893[XX].018
19'	815[XX]19.000(X)	B3109893[XX].019
20'	815[XX]20.000(X)	B3109893[XX].020
21'	815[XX]21.000(X)	B3109893[XX].021

[XX]=Fabric Color Code: BR=Blue Shadow, BS=Sand Shadow, B]=Teal Shadow, CM=Forest Green Shadow, BQ=Burgundy Shadow, BT=Black & Gray Shadow

(X)=Weathershield Finish Code: B=Polar White, R=Champagne, S=Satin, U=Black

* Metal weathershield not included.

Replacement fabrics are non returnable. Fabrics measure approximately 9" shorter than stated size of awning. Note colors are subject to change without notice.

HARDWARE & ACCESSORIES

MOTOR

ORDER NUMBER

3307923.115X Replacement Motor

HARDWARE

ORDER NUMBER

8551201.400(X) Basement Model
 8551202.400(X) Standard Model
 8551203.400(X) Fifth Wheel - Basement
 8551204.400(X) Fifth Wheel - Standard
 3108710.199 Stand Off Bracket Kit (Optional)

(X)=Hardware Color Code: B=Polar White, R=Champagne, S=Satin, U=Black

CONTROL KIT

ORDER NUMBER

3311917.029 Control Kit

Contains: Control box, wind sensor, wiring harness, key fob remote control.

Note: Must have control kit for initial installation

VINYL FABRIC

Fade pattern, Metal weathershield

SIZE	FRTA	REPLACEMENT FABRICS*
12'	805[XX]12.000(X)	B3108056[XX].412
13'	805[XX]13.000(X)	B3108056[XX].413
14'	805[XX]14.000(X)	B3108056[XX].414
15'	805[XX]15.000(X)	B3108056[XX].415
16'	805[XX]16.000(X)	B3108056[XX].416
17'	805[XX]17.000(X)	B3108056[XX].417
18'	805[XX]18.000(X)	B3108056[XX].418
19'	805[XX]19.000(X)	B3108056[XX].419
20'	805[XX]20.000(X)	B3108056[XX].420
21'	805[XX]21.000(X)	B3108056[XX].421

[XX]=Fabric Color Code: NR=Onyx, NS=Sandstone, NV=Maroon, NT=Azure, NW=Meadow Green, NU=Bark, **FG=Race Flag, **FM=Rodeo

(X)=Weathershield Finish Code: B=Polar White, R=Champagne, S=Satin, U=Black

* Metal weathershield not included.

** Race Flag and Rodeo fabric - Add \$25 to each length.

Replacement fabrics are non returnable. Fabrics measure approximately 9" shorter than stated size of awning. Note colors are subject to change without notice.

REPLACEMENT ROLLER TUBES

SIZE ORDER NUMBER

12' 3108346.012
 13' 3108346.013
 14' 3108346.014
 15' 3108346.015
 16' 3108346.016
 17' 3108346.017
 18' 3108346.018
 19' 3108346.019
 20' 3108346.020
 21' 3108346.021

For window awnings to match see pages 26-28

For door awnings to match see page 25

9100 POWERCHANNEL AWNINGS

Patio | Automatic | Vinyl or Metal

The PowerChannel is an innovative and convenient option available with the 9100 Power Awning. The awning's roller tube contains the PowerChannel which provides a track of electrical power along its entire length that Dometic accessories can tap into without using any cords or wires.

VINYL FABRIC

Fade pattern, Metal or vinyl weathershield

SIZE	FRTA METAL WEATHERSHIELD	FRTA VINYL WEATHERSHIELD
10'	651[XX]10.000(X)	601[XX]10.000(X)
11'	651[XX]11.000(X)	601[XX]11.000(X)
12'	651[XX]12.000(X)	601[XX]12.000(X)
13'	651[XX]13.000(X)	601[XX]13.000(X)
14'	651[XX]14.000(X)	601[XX]14.000(X)
15'	651[XX]15.000(X)	601[XX]15.000(X)
16'	651[XX]16.000(X)	601[XX]16.000(X)
17'	651[XX]17.000(X)	601[XX]17.000(X)
18'	651[XX]18.000(X)	601[XX]18.000(X)
19'	651[XX]19.000(X)	601[XX]19.000(X)
20'	651[XX]20.000(X)	601[XX]20.000(X)
21'	651[XX]21.000(X)	601[XX]21.000(X)

[XX]=Fabric Color Code: NR=Onyx, NS=Sandstone, NV=Maroon, NT=Azure, NW=Meadow Green, NU=Bark, **FG=Race Flag, **FM=Rodeo

(X)=Endcap Finish Code: B=Polar White, R=Champagne, P=Silver, U=Black

** Race Flag and Rodeo fabric - Add \$25 to each length.

*** For color coordination vinyl weathershield, replace .000(X) with one of the following:
.300(X) - Black vinyl weathershield: Available only with fabric colors Onyx (NR) or Bark (NU)
.600(X) - Beige vinyl weathershield: Available only with fabric color Sandstone (NS)

HARDWARE & ACCESSORIES

HARDWARE

ORDER NUMBER

8956001.400(X)	Basement Model
8956002.400(X)	Standard Model
3312778.008(X)	Bracket Adapters (8500/9100 - Replace 8500 with 9100)

(X)=Hardware Finish Code: B=Polar White, R=Champagne, P=Silver, U=Black

ACCESSORIES

ORDER NUMBER

3316287.000	Control Switch Kit
-------------	--------------------

Note: Must have control switch for initial installation

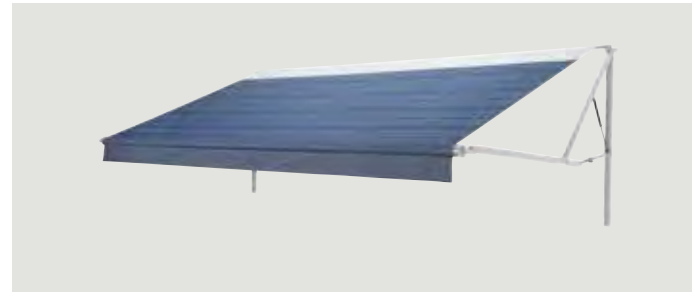

WOVEN ACRYLIC FABRIC

Shadow pattern, Metal weathershield

SIZE	FRTA METAL WEATHERSHIELD
10'	654[XX]10.000(X)
11'	654[XX]11.000(X)
12'	654[XX]12.000(X)
13'	654[XX]13.000(X)
14'	654[XX]14.000(X)
15'	654[XX]15.000(X)
16'	654[XX]16.000(X)
17'	654[XX]17.000(X)
18'	654[XX]18.000(X)
19'	654[XX]19.000(X)
20'	654[XX]20.000(X)
21'	654[XX]21.000(X)

[XX]=Fabric Color Code: BR=Blue Shadow, BS=Sand Shadow, BJ=Teal Shadow, CM=Forest Green Shadow, BQ=Burgundy Shadow, BT=Black & Gray Shadow

(X)=Weathershield Finish Code: B=Polar White, R=Champagne, P=Silver, U=Black



POWERCHANNEL RAIL & ACCESSORIES

POWERCHANNEL RAIL

ORDER NUMBER

3316282.003U	2 ft.
3316282.004U	4 ft.

ACCESSORIES

ORDER NUMBER

3316022.000	Fan
3316023.000	Bluetooth Speaker
3316024.000	LED Spotlight

For window awnings to match see pages 26-28

For door awnings to match see page 25

9100 POWER AWNING

Patio | Automatic | Vinyl or Metal

The 9100 Power Awning is a value leader that compliments any RV.

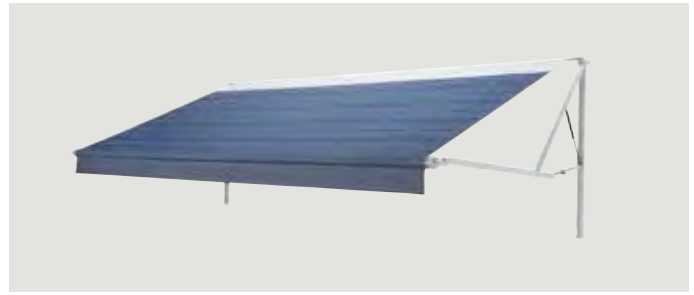

VINYL FABRIC

Fade pattern, Metal or vinyl weathershield

SIZE	FRTA METAL WEATHERSHIELD	FRTA VINYL WEATHERSHIELD
10'	917[XX]10.000(X)	915[XX]10.000(X)
11'	917[XX]11.000(X)	915[XX]11.000(X)
12'	917[XX]12.000(X)	915[XX]12.000(X)
13'	917[XX]13.000(X)	915[XX]13.000(X)
14'	917[XX]14.000(X)	915[XX]14.000(X)
15'	917[XX]15.000(X)	915[XX]15.000(X)
16'	917[XX]16.000(X)	915[XX]16.000(X)
17'	917[XX]17.000(X)	915[XX]17.000(X)
18'	917[XX]18.000(X)	915[XX]18.000(X)
19'	917[XX]19.000(X)	915[XX]19.000(X)
20'	917[XX]20.000(X)	915[XX]20.000(X)
21'	917[XX]21.000(X)	915[XX]21.000(X)

[XX]=Fabric Color Code: NR=Onyx, NS=Sandstone, NV=Maroon, NT=Azure, NW=Meadow Green, NU=Bark, **FG=Race Flag, **FM=Rodeo

(X)=Endcap Finish Code: B=Polar White, R=Champagne, P=Silver, U=Black

** Race Flag and Rodeo fabric - Add \$25 to each length.

*** For color coordination vinyl weathershield, replace .000(X) with one of the following:

.300(X) - Black vinyl weathershield: Available only with fabric colors Onyx (NR) or Bark (NU)

.600(X) - Beige vinyl weathershield: Available only with fabric color Sandstone (NS)

WOVEN ACRYLIC FABRIC

Shadow pattern, Metal weathershield

SIZE	FRTA METAL WEATHERSHIELD
10'	910[XX]10.000(X)
11'	910[XX]11.000(X)
12'	910[XX]12.000(X)
13'	910[XX]13.000(X)
14'	910[XX]14.000(X)
15'	910[XX]15.000(X)
16'	910[XX]16.000(X)
17'	910[XX]17.000(X)
18'	910[XX]18.000(X)
19'	910[XX]19.000(X)
20'	910[XX]20.000(X)
21'	910[XX]21.000(X)

[XX]=Fabric Color Code: BR=Blue Shadow, BS=Sand Shadow, BJ=Teal Shadow, CM=Forest Green Shadow, BQ=Burgundy Shadow, BT=Black & Gray Shadow

(X)=Weathershield Finish Code: B=Polar White, R=Champagne, P=Silver, U=Black

HARDWARE & ACCESSORIES

HARDWARE

ORDER NUMBER

8952001.400(X)	Basement Model
8952002.400(X)	Standard Model
3312778.008(X)	Bracket Adapters (8500/9100 - Replace 8500 with 9100)

(X)=Hardware Finish Code: B=Polar White, R=Champagne, P=Silver, U=Black

ACCESSORIES

ORDER NUMBER

3109987.002	Aux. Operation Kit
3310455.062	Control Switch

Note: Must have control switch for initial installation

POWER AWNING PRO

- Sleek, easy-to-use hand-held remote control
- Can control LED light strip, including dimming
- Adds wind sensor to current power awning
- Can work in tandem with existing wall switch
- Easy to upgrade

ORDER NUMBER

3316554.002	Power Awning Pro White
3316554.005	Power Awning Pro Black

For window awnings to match see pages 26-28

For door awnings to match see page 25

9100 MANUAL AWNINGS

Patio | Manual | Vinyl or Metal

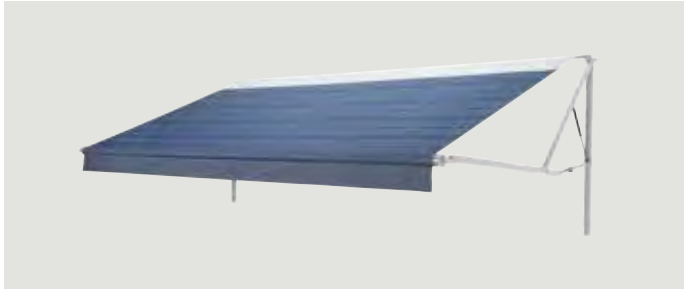

VINYL FABRIC

Fade pattern, Metal or vinyl weathershield

SIZE	FRTA METAL WEATHERSHIELD	FRTA VINYL WEATHERSHIELD
8'	957[XX]08.000(X)	955[XX]08.000(X)
9'	957[XX]09.000(X)	955[XX]09.000(X)
10'	957[XX]10.000(X)	955[XX]10.000(X)
11'	957[XX]11.000(X)	955[XX]11.000(X)
12'	957[XX]12.000(X)	955[XX]12.000(X)
13'	957[XX]13.000(X)	955[XX]13.000(X)
14'	957[XX]14.000(X)	955[XX]14.000(X)
15'	957[XX]15.000(X)	955[XX]15.000(X)
16'	957[XX]16.000(X)	955[XX]16.000(X)
17'	957[XX]17.000(X)	955[XX]17.000(X)
18'	957[XX]18.000(X)	955[XX]18.000(X)
19'	957[XX]19.000(X)	955[XX]19.000(X)
20'	957[XX]20.000(X)	955[XX]20.000(X)
21'	957[XX]21.000(X)	955[XX]21.000(X)

[XX]=Fabric Color Code: NR=Onyx, NS=Sandstone, NV=Maroon, NT=Azure, NW=Meadow Green, NU=Bark, **FG=Race Flag, **FM=Rodeo

(X)=Endcap Finish Code: B=Polar White, R=Champagne, P=Silver, U=Black

** Race Flag and Rodeo fabric - Add \$25 to each length.

WOVEN ACRYLIC FABRIC

Shadow pattern, Metal weathershield

SIZE	FRTA METAL WEATHERSHIELD
8'	950[XX]08.000(X)
9'	950[XX]09.000(X)
10'	950[XX]10.000(X)
11'	950[XX]11.000(X)
12'	950[XX]12.000(X)
13'	950[XX]13.000(X)
14'	950[XX]14.000(X)
15'	950[XX]15.000(X)
16'	950[XX]16.000(X)
17'	950[XX]17.000(X)
18'	950[XX]18.000(X)
19'	950[XX]19.000(X)
20'	950[XX]20.000(X)
21'	950[XX]21.000(X)

[XX]=Fabric Color Code: BR=Blue Shadow, BS=Sand Shadow, BJ=Teal Shadow, CM=Forest Green Shadow, BQ=Burgundy Shadow, BT=Black & Gray Shadow

(X)=Weathershield Finish Code: B=Polar White, R=Champagne, P=Silver, U=Black

HARDWARE & ACCESSORIES

HARDWARE

ORDER NUMBER

8942001.400(X)	Basement Model
8942002.400(X)	Standard Model

(X)=Hardware Finish Code: B=Polar White, R=Champagne, P=Silver, U=Black

COMPANION ACCESSORIES

Veranda Room see page 45

Veranda Shade see page 45

For window awnings to match see pages 26-28

For door awnings to match see page 25

9500 CASE AWNINGS

Patio | Manual or Power

- 5°/15° Fabric Angle
- Lateral arms
- Manual pitch adjustment
- Automatic Rain Shed
- 8' = 68" projection
- 10' = 86" projection
- 12' & up = 96" projection
- Preinstalled LED light Available - Add "L" to end of item no.

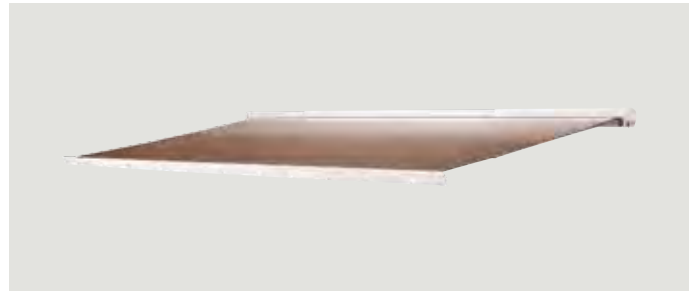

VINYL WEATHERSHIELD

Fade pattern

SIZE	MANUAL	POWER
8'	200[XX]08.003(X)	201[XX]08.003(X)
10'	200[XX]10.003(X)	201[XX]10.003(X)
12'	200[XX]12.003(X)	201[XX]12.003(X)
13'	200[XX]13.003(X)	201[XX]13.003(X)
15'	200[XX]15.003(X)	201[XX]15.003(X)
16'	200[XX]16.003(X)	201[XX]16.003(X)

[XX]=Fabric Color Code: NR=Onyx, NS=Sandstone, NV=Maroon, NT=Azure, NW=Meadow Green, NU=Bark, **FG=Race Flag, **FM=Rodeo

(X)=Endcap Finish Code: B=Polar White, P=Silver, U=Black

** Race Flag and Rodeo fabric - Add \$25 to each length.

VINYL WITH METAL WEATHERSHIELD

Fade pattern

SIZE	REPLACEMENT FABRICS*
8'	B3313839[XX].008
10'	B3313839[XX].010
12'	B3313839[XX].012
13'	B3313839[XX].013
15'	B3313839[XX].015
16'	B3313839[XX].016

[XX]=Fabric Color Code: NR=Onyx, NS=Sandstone, NV=Maroon, NT=Azure, NW=Meadow Green, NU=Bark, **FG=Race Flag, **FM=Rodeo

** Race Flag and Rodeo fabric - Add \$25 to each length.

Replacement fabrics are non returnable. Fabrics measure approximately 9" shorter than stated size of awning. Note colors are subject to change without notice.

COMPANION ACCESSORIES

Veranda Room see page 45

Veranda Shade see page 45

For window awnings to match see pages 26-28

For door awnings to match see page 25

9000™ GEARED AWNINGS

Patio | Manual | Acrylic

WOVEN ACRYLIC FABRIC

Shadow pattern, Metal weathershield

SIZE	FRTA METAL WEATHERSHIELD
8'	G839[XX]08.000(X)
9'	G839[XX]09.000(X)
10'	G839[XX]10.000(X)
11'	G839[XX]11.000(X)
12'	G839[XX]12.000(X)
13'	G839[XX]13.000(X)
14'	G839[XX]14.000(X)
15'	G839[XX]15.000(X)
16'	G839[XX]16.000(X)
17'	G839[XX]17.000(X)
18'	G839[XX]18.000(X)
19'	G839[XX]19.000(X)
20'	G839[XX]20.000(X)
21'	G839[XX]21.000(X)
22'	G839[XX]22.000(X)
23'	G839[XX]23.000(X)
24'	G839[XX]24.000(X)
25'	G839[XX]25.000(X)

[XX]=Fabric Color Code: BR=Blue Shadow, BS=Sand Shadow, B]=Teal Shadow, CM=Forest Green Shadow, BQ=Burgundy Shadow, BT=Black & Gray Shadow

(X)=Weathershield Finish Code: B=Polar White, R=Champagne, P=Silver, U=Black

8500™ GEARED AWNINGS

Patio | Manual | Vinyl or Metal

VINYL FABRIC

Fade pattern, Metal or vinyl weathershield

SIZE	FRTA METAL WEATHERSHIELD	FRTA VINYL WEATHERSHIELD
8'	G858[XX]08.400(X)	G848[XX]08.400(X)
9'	G858[XX]09.400(X)	G848[XX]09.400(X)
10'	G858[XX]10.400(X)	G848[XX]10.400(X)
11'	G858[XX]11.400(X)	G848[XX]11.400(X)
12'	G858[XX]12.400(X)	G848[XX]12.400(X)
13'	G858[XX]13.400(X)	G848[XX]13.400(X)
14'	G858[XX]14.400(X)	G848[XX]14.400(X)
15'	G858[XX]15.400(X)	G848[XX]15.400(X)
16'	G858[XX]16.400(X)	G848[XX]16.400(X)
17'	G858[XX]17.400(X)	G848[XX]17.400(X)
18'	G858[XX]18.400(X)	G848[XX]18.400(X)
19'	G858[XX]19.400(X)	G848[XX]19.400(X)
20'	G858[XX]20.400(X)	G848[XX]20.400(X)
21'	G858[XX]21.400(X)	G848[XX]21.400(X)
22'	G858[XX]22.400(X)	G848[XX]22.400(X)
23'	G858[XX]23.400(X)	G848[XX]23.400(X)
24'	G858[XX]24.400(X)	G848[XX]24.400(X)
25'	G858[XX]25.400(X)	G848[XX]25.400(X)

[XX]=Fabric Color Code: NR=Onyx, NS=Sandstone, NV=Maroon, NT=Azure, NW=Meadow Green, NU=Bark, **FG=Race Flag, **FM=Rodeo

(X)=Endcap Finish Code: B=Polar White, R=Champagne, P=Silver, U=Black

** Race Flag and Rodeo fabric - Add \$25 to each length.

UNIVERSAL HARDWARE SETS

FOR STRAIGHT SIDE VEHICLES

ORDER NUMBER	
G8273000.401(X)	Tall
G8273000.402(X)	Short
G8273000.408(X)	Tall/Short Combo
G8273000.501(X)	Tall, Heavy-Duty
G8273000.502(X)	Short, Heavy-Duty

(X)=Hardware Finish Code: B=Polar White, R=Champagne, P=Silver, U=Black

See pages 43-44 for correct sizes.

Note: Optima Tension Rafter System included in H.D. hardware

UNIVERSAL HARDWARE SETS

FOR STRAIGHT SIDE VEHICLES

ORDER NUMBER	
G8273000.401(X)	Tall
G8273000.402(X)	Short
G8273000.408(X)	Tall/Short Combo
G8273000.501(X)	Tall, Heavy-Duty
G8273000.502(X)	Short, Heavy-Duty

(X)=Hardware Finish Code: B=Polar White, R=Champagne, P=Silver, U=Black

See pages 43-44 for correct sizes.

Note: Optima Tension Rafter System included in H.D. hardware

SUNCHASER™ GEARED AWNINGS

Patio | Manual | Vinyl



CLIMATE

FOOD & BEVERAGE

HYGIENE & SANITATION

SAFETY & SECURITY

VINYL FABRIC

Summer shade vinyl, Vinyl weathershield

SIZE FRTA VINYL WEATHERSHIELD

8'	G803[XX]08.400(X)
9'	G803[XX]09.400(X)
10'	G803[XX]10.400(X)
11'	G803[XX]11.400(X)
12'	G803[XX]12.400(X)
13'	G803[XX]13.400(X)
14'	G803[XX]14.400(X)
15'	G803[XX]15.400(X)
16'	G803[XX]16.400(X)
17'	G803[XX]17.400(X)
18'	G803[XX]18.400(X)
19'	G803[XX]19.400(X)
20'	G803[XX]20.400(X)
21'	G803[XX]21.400(X)

[XX]=Fabric Color Code: GP= Blue Steel, HE=Cranberry, GU=Bamboo, GV=Bark, GW=Flint, GS=Meadow Green

(X)=Endcap Finish Code: B=Polar White, R=Champagne, P=Silver, U=Black

UNIVERSAL HARDWARE SETS

FOR STRAIGHT SIDE VEHICLES

ORDER NUMBER

G8273000.401(X)	Tall
G8273000.402(X)	Short
G8273000.408(X)	Tall/Short Combo

(X)=Hardware Finish Code: B=Polar White, R=Champagne, P=Silver, U=Black

See pages 43-44 for correct sizes.

Note: Optima Tension Rafter System included in H.D. hardware

COMPANION ACCESSORIES

Veranda Room see page 45

Veranda Shade see page 45

DOOR AWNINGS

Door | Automatic | Manual

ELITE OASIS™ II DOOR AWNINGS - POWER

- 48" or 56" from end of case to end of case, both manual and electric
- Six woven acrylic colors or white vinyl
- All-metal case: 3"D x 5" W, 34" Extension

ORDER NUMBER

975CQ48.010(X)	Polar White Vinyl 0.48"
975CQ56.010(X)	Polar White Vinyl 0.56"
975[XX]48.110(X)	Acrylic 0.48"
975[XX]56.110(X)	Acrylic 0.56"

[XX]=Fabric Color Code: BL=Forest Green, DA=Burgundy, EE=Linen Tweed, CD=Sapphire, EK=Charcoal Gray

(X)=Case Color Code: B=Polar White, R=Champagne, S=Satin, U=Black



OASIS™ II DOOR AWNINGS - MANUAL

- Ideal for trailers and campers as well as motorhomes

ORDER NUMBER

976CQ48.010(X)	Polar White Vinyl 0.48"
976CQ56.010(X)	Polar White Vinyl 0.56"
976[XX]48.110(X)	Acrylic 0.48"
976[XX]56.110(X)	Acrylic 0.56"

[XX]=Fabric Color Code: BL=Forest Green, DA=Burgundy, EE=Linen Tweed, CD=Sapphire, EK=Charcoal Gray

(X)=Case Color Code: B=Polar White, R=Champagne, S=Satin, U=Black

OASIS™ II CONTROLS

ORDER NUMBER

3311917.029	Complete control box Required for electric awning
3109688.006	Remote switch assembly for WeatherPro Control Order additionally for WeatherPro

ELITE™ STANDARD WINDOW AWNINGS

Window | Acrylic | Monochromatic

- Use with window height under 30"

WOVEN ACRYLIC FABRIC

Shadow pattern, Metal weathershield

SIZE	FRTA	REPLACEMENT FABRICS*
30"	85662[XX].0300-(X)	B83037[XX].030
36"	85662[XX].0360-(X)	B83037[XX].036
42"	85662[XX].0420-(X)	B83037[XX].042
48"	85662[XX].0480-(X)	B83037[XX].048
54"	85662[XX].0540-(X)	B83037[XX].054
60"	85662[XX].0600-(X)	B83037[XX].060
66"	85662[XX].0660-(X)	B83037[XX].066
72"	85662[XX].0720-(X)	B83037[XX].072
78"	85662[XX].0780-(X)	B83037[XX].078
84"	85662[XX].0840-(X)	B83037[XX].084
90"	85662[XX].0900-(X)	B83037[XX].090
96"	85662[XX].0960-(X)	B83037[XX].096
108"	85662[XX].1080-(X)	B83037[XX].108
114"	85662[XX].1140-(X)	B83037[XX].114
120"	85662[XX].1200-(X)	B83037[XX].120
132"	85662[XX].1320-(X)	B83037[XX].132
138"	85662[XX].1380-(X)	B83037[XX].138
144"	85662[XX].1440-(X)	B83037[XX].144
156"	85662[XX].1560-(X)	B83037[XX].156

[XX]=Fabric Color Code: B=Teal Shadow, BR=Blue, CM=Forest Green, BS=Sand, BQ=Burgundy, BT=Black/Grey

(X)=Weathershield Color Code: B=Polar White, R=Champagne, P=Silver, U=Black

* Metal weathershield not included.

Replacement fabrics are non returnable. Fabrics measure approximately 9" shorter than stated size of awning. Note colors are subject to change without notice.

HARDWARE

Mounting bracket color matches arms, 18" arms

ORDER NUMBER

830757.002P	Silver Finish
830757.002B	Polar White
830757.002R	Champagne
830757.002U	Black

(X)=Hardware Finish Code: B=Polar White, R=Champagne, P=Silver, U=Black

ELITE™ TALL WINDOW AWNINGS

Window | Acrylic | Monochromatic

- Use with window height = 30" or greater

WOVEN ACRYLIC FABRIC

Shadow pattern, Metal weathershield

SIZE	FRTA	REPLACEMENT FABRICS*
30"	85690[XX].0300-(X)	B83037[XX].030
36"	85690[XX].0360-(X)	B83037[XX].036
42"	85690[XX].0420-(X)	B83037[XX].042
48"	85690[XX].0480-(X)	B83037[XX].048
54"	85690[XX].0540-(X)	B83037[XX].054
60"	85690[XX].0600-(X)	B83037[XX].060
66"	85690[XX].0660-(X)	B83037[XX].066
72"	85690[XX].0720-(X)	B83037[XX].072
78"	85690[XX].0780-(X)	B83037[XX].078
84"	85690[XX].0840-(X)	B83037[XX].084
90"	85690[XX].0900-(X)	B83037[XX].090
96"	85690[XX].0960-(X)	B83037[XX].096
108"	85690[XX].1080-(X)	B83037[XX].108
114"	85690[XX].1140-(X)	B83037[XX].114
120"	85690[XX].1200-(X)	B83037[XX].120
132"	85690[XX].1320-(X)	B83037[XX].132
138"	85690[XX].1380-(X)	B83037[XX].138
144"	85690[XX].1440-(X)	B83037[XX].144
156"	85690[XX].1560-(X)	B83037[XX].156

[XX]=Fabric Color Code: B=Teal Shadow, BR=Blue, CM=Forest Green, BS=Sand, BQ=Burgundy, BT=Black/Grey

(X)=Weathershield Color Code: B=Polar White, R=Champagne, P=Silver, U=Black

HARDWARE

Mounting bracket color matches arms, 30" arms

ORDER NUMBER

830757.001P	Silver Finish
830757.001B	Polar White
830757.001R	Champagne
830757.001U	Black

(X)=Hardware Finish Code: B=Polar White, R=Champagne, P=Silver, U=Black

DELUXE PLUS™ STANDARD WINDOW AWNINGS

Window | Vinyl | Monochromatic

- Use with window height under 30"

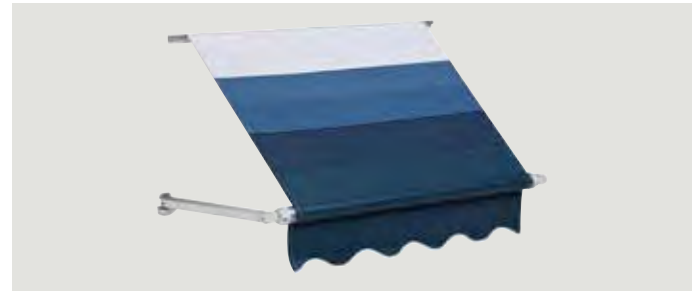

VINYL FABRIC

Fade pattern, Metal weathershield

SIZE	FRTA METAL WEATHERSHIELD	REPLACEMENT FABRICS*
30"	85630[XX].030(X)	B3108057[XX].030
36"	85630[XX].036(X)	B3108057[XX].036
42"	85630[XX].042(X)	B3108057[XX].042
48"	85630[XX].048(X)	B3108057[XX].048
54"	85630[XX].054(X)	B3108057[XX].054
60"	85630[XX].060(X)	B3108057[XX].060
66"	85630[XX].066(X)	B3108057[XX].066
72"	85630[XX].072(X)	B3108057[XX].072
78"	85630[XX].078(X)	B3108057[XX].078
84"	85630[XX].084(X)	B3108057[XX].084
90"	85630[XX].090(X)	B3108057[XX].090
96"	85630[XX].096(X)	B3108057[XX].096
108"	85630[XX].108(X)	B3108057[XX].108
114"	85630[XX].114(X)	B3108057[XX].114
120"	85630[XX].120(X)	B3108057[XX].120
132"	85630[XX].132(X)	B3108057[XX].132
144"	85630[XX].144(X)	B3108057[XX].144
156"	85630[XX].156(X)	B3108057[XX].156

[XX]=Fabric Color Code: NR=Onyx, NS=Sandstone, NV=Maroon, NT=Azure, NW=Meadow Green, NU=Bark, F]=Black, CQ=White,

**FG=Race Flag, **FM=Rodeo

(X)=Weathershield Color Code: B=Polar White, R=Champagne, P=Silver, U=Black

** Race Flag and Rodeo fabric - Add \$25 to each length.

VINYL FABRIC

Fade pattern, Vinyl weathershield

SIZE	FRTA VINYL WEATHERSHIELD*	REPLACEMENT FABRICS*
30"	85604[XX].0300-(X)	B3105194[XX].030
36"	85604[XX].0360-(X)	B3105194[XX].036
42"	85604[XX].0420-(X)	B3105194[XX].042
48"	85604[XX].0480-(X)	B3105194[XX].048
54"	85604[XX].0540-(X)	B3105194[XX].054
60"	85604[XX].0600-(X)	B3105194[XX].060
66"	85604[XX].0660-(X)	B3105194[XX].066
72"	85604[XX].0720-(X)	B3105194[XX].072
78"	85604[XX].0780-(X)	B3105194[XX].078
84"	85604[XX].0840-(X)	B3105194[XX].084
90"	85604[XX].0900-(X)	B3105194[XX].090
96"	85604[XX].0960-(X)	B3105194[XX].096
108"	85604[XX].1080-(X)	B3105194[XX].108
114"	85604[XX].1140-(X)	B3105194[XX].114
120"	85604[XX].1200-(X)	B3105194[XX].120
132"	85604[XX].1320-(X)	B3105194[XX].132
144"	85604[XX].1440-(X)	B3105194[XX].144
156"	85604[XX].1560-(X)	B3105194[XX].156

[XX]=Fabric Color Code: NR=Onyx, NS=Sandstone, NV=Maroon, NT=Azure, NW=Meadow Green, NU=Bark, F]=Black, CQ=White,

**FG=Race Flag, **FM=Rodeo

(X)=Hardware Color Code: B=Polar White, R=Champagne, P=Silver, U=Black

** Race Flag and Rodeo fabric - Add \$25 to each length.

HARDWARE

18" ARMS

830757.002P	Silver Finish
830757.002B	Polar White
830757.002R	Champagne
830757.002U	Black

(X)=Hardware Finish Code: B=Polar White, R=Champagne, P=Silver, U=Black

WINDOW AWNING FRTA

3307834.006	28" Window awning black pull strap
3109804.017	45" Window awning black pull strap
3107025P003(X)	Strap Hook

(X)=Hardware Finish Code: B=Polar White, R=Champagne, P=Silver, U=Black

DELUXE PLUS™ TALL WINDOW AWNINGS

Window | Vinyl | Monochromatic

- Use with window height = 30" or greater

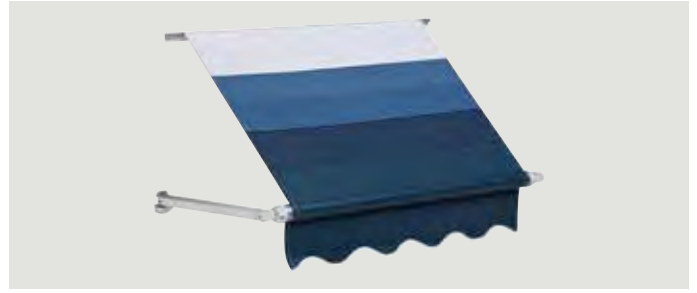

VINYL FABRIC

Fade pattern, Metal weathershield

SIZE	FRTA METAL WEATHERSHIELD	REPLACEMENT FABRICS*
30"	85620[XX].0300-(X)	B3109163[XX].030
36"	85620[XX].0360-(X)	B3109163[XX].036
42"	85620[XX].0420-(X)	B3109163[XX].042
48"	85620[XX].0480-(X)	B3109163[XX].048
54"	85620[XX].0540-(X)	B3109163[XX].054
60"	85620[XX].0600-(X)	B3109163[XX].060
66"	85620[XX].0660-(X)	B3109163[XX].066
72"	85620[XX].0720-(X)	B3109163[XX].072
78"	85620[XX].0780-(X)	B3109163[XX].078
84"	85620[XX].0840-(X)	B3109163[XX].084
90"	85620[XX].0900-(X)	B3109163[XX].090
96"	85620[XX].0960-(X)	B3109163[XX].096
108"	85620[XX].1080-(X)	B3109163[XX].108
114"	85620[XX].1140-(X)	B3109163[XX].114
120"	85620[XX].1200-(X)	B3109163[XX].120
132"	85620[XX].1320-(X)	B3109163[XX].132
144"	85620[XX].1440-(X)	B3109163[XX].144
156"	85620[XX].1560-(X)	B3109163[XX].156

[XX]=Fabric Color Code: NR=Onyx, NS=Sandstone, NV=Maroon, NT=Azure, NW=Meadow Green, NU=Bark, F]=Black, CQ=White, **FG=Race Flag, **FM=Rodeo

(X)=Weathershield Color Code: B=Polar White, R=Champagne, P=Silver, U=Black

** Race Flag and Rodeo fabric - Add \$25 to each length.

VINYL FABRIC

Fade pattern, Vinyl weathershield

SIZE	FRTA VINYL WEATHERSHIELD	REPLACEMENT FABRICS*
30"	85610[XX].0300-(X)	B3109161[XX].030
36"	85610[XX].0360-(X)	B3109161[XX].036
42"	85610[XX].0420-(X)	B3109161[XX].042
48"	85610[XX].0480-(X)	B3109161[XX].048
54"	85610[XX].0540-(X)	B3109161[XX].054
60"	85610[XX].0600-(X)	B3109161[XX].060
66"	85610[XX].0660-(X)	B3109161[XX].060
72"	85610[XX].0720-(X)	B3109161[XX].072

[XX]=Fabric Color Code: NR=Onyx, NS=Sandstone, NV=Maroon, NT=Azure, NW=Meadow Green, NU=Bark, F]=Black, CQ=White, **FG=Race Flag, **FM=Rodeo

(X)=Hardware Color Code: B=Polar White, R=Champagne, P=Silver, U=Black

** Race Flag and Rodeo fabric - Add \$25 to each length.

HARDWARE

30" ARMS

830757.001P	Silver Finish
830757.001B	Polar White
830757.001R	Champagne
830757.001U	Black

(X)=Hardware Finish Code: B=Polar White, R=Champagne, P=Silver, U=Black

WINDOW AWNING FRTA

3307834.006	28" Window awning black pull strap
3109804.017	45" Window awning black pull strap
3107025P003(X)	Strap Hook

(X)=Hardware Finish Code: B=Polar White, R=Champagne, P=Silver, U=Black



DETERMINING SIZE OF SLIDETOPPER™

HOW TO MEASURE FOR YOUR SLIDETOPPER:

To determine which size of SlideTopper you require, measure your room according to the picture and reference chart below. The SlideTopper will not work on rooms with a full extension greater than 42".

ROOM WIDTH	RECOMMENDED SIZE
56" to 61.75"	66"
62" to 67.75"	75"
68" to 73.75"	78"
74" to 79.75"	84"
80" to 85.75"	90"
86" to 91.75"	96"
92" to 97.75"	102"
98" to 103.75"	108"
104" to 109.75"	114"
110" to 115.75"	120"
116" to 121.75"	126"
122" to 127.75"	132"
128" to 133.75"	138"
134" to 139.75"	144"
140" to 145.75"	150"
146" to 151.75"	156"
152" to 157.75"	162"
158" to 163.75"	168"
164" to 169.75"	174"
170" to 175.75"	180"
176" to 181.75"	186"
182" to 187.75"	192"

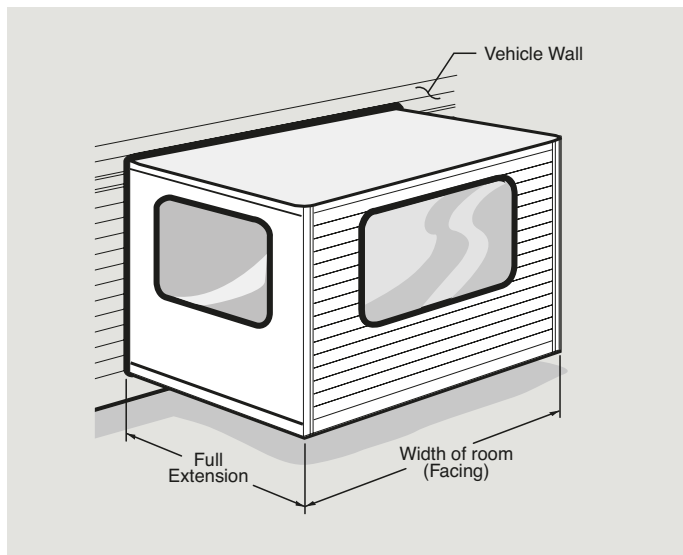

FULL COVER SLIDETOPPER™ AWNINGS

Full Cover SlideTopper™ | Vinyl

VINYL FABRIC

Solid color, vinyl weathershield

SIZE	FRTA	REPLACEMENT FABRICS*
66"	86196[XX].066-(X)	B3106802[XX].066
72"	86196[XX].072-(X)	B3106802[XX].072
78"	86196[XX].078-(X)	B3106802[XX].078
84"	86196[XX].084-(X)	B3106802[XX].084
90"	86196[XX].090-(X)	B3106802[XX].090
96"	86196[XX].096-(X)	B3106802[XX].096
102"	86196[XX].102-(X)	B3106802[XX].102
108"	86196[XX].108-(X)	B3106802[XX].108
114"	86196[XX].114-(X)	B3106802[XX].144
120"	86196[XX].120-(X)	B3106802[XX].120
126"	86196[XX].120-(X)	B3106802[XX].126
132"	86196[XX].126-(X)	B3106802[XX].132
138"	86196[XX].132-(X)	B3106802[XX].138
144"	86196[XX].144-(X)	B3106802[XX].144
150"	86196[XX].150-(X)	B3106802[XX].150
156"	86196[XX].156-(X)	B3106802[XX].156
162"	86196[XX].162-(X)	B3106802[XX].162
168"	86196[XX].168-(X)	B3106802[XX].168
174"	86196[XX].174-(X)	B3106802[XX].174
180"	86196[XX].180-(X)	B3106802[XX].180
186"	86196[XX].186-(X)	B3106802[XX].186
192"	86196[XX].192-(X)	B3106802[XX].192
198"	86196[XX].198-(X)	B3106802[XX].198

[XX]=Fabric Color Code: CQ=Polar White, **F]=Black, **FN=Satin

(X)=Finish Color Code: B=Polar White, R=Champagne, S=Satin, U=Black

** Add \$30 to each length.

* Replacement fabrics are non returnable. Replacement fabrics ordered as actual size of SlideTopper. Order fabrics by SlideTopper size not fabric size.

HARDWARE

ORDER NUMBER

3106992.062(X)	45° Brackets
3106992.070(X)	90° Brackets
3312418.000(X)	Anti-billowing Assembly
3107198.347(X)	Spacer Kit

(X)=Hardware Finish Code: B=Polar White, R=Champagne, S=Satin, U=Black

ELITE SLIDETOPPER™ AWNINGS

SlideTopper | Vinyl

ELITE SLIDETOPPER

Vinyl Fabric, Metal weathershield

SIZE	FRTA METAL WEATHERSHIELD	REPLACEMENT FABRICS*
66"	98401[XX].066(X)	B3106810[XX].066
72"	98401[XX].072(X)	B3106810[XX].072
78"	98401[XX].078(X)	B3106810[XX].078
84"	98401[XX].084(X)	B3106810[XX].084
90"	98401[XX].090(X)	B3106810[XX].090
96"	98401[XX].096(X)	B3106810[XX].096
102"	98401[XX].102(X)	B3106810[XX].102
108"	98401[XX].108(X)	B3106810[XX].108
114"	98401[XX].114(X)	B3106810[XX].114
120"	98401[XX].120(X)	B3106810[XX].120
126"	98401[XX].126(X)	B3106810[XX].126
132"	98401[XX].132(X)	B3106810[XX].132
138"	98401[XX].138(X)	B3106810[XX].138
144"	98401[XX].144(X)	B3106810[XX].144
150"	98401[XX].150(X)	B3106810[XX].150
156"	98401[XX].156(X)	B3106810[XX].156
162"	98401[XX].162(X)	B3106810[XX].162
168"	98401[XX].168(X)	B3106810[XX].168
174"	98401[XX].174(X)	B3106810[XX].174
180"	98401[XX].180(X)	B3106810[XX].180
186"	98401[XX].186(X)	B3106810[XX].186
192"	98401[XX].192(X)	B3106810[XX].192

[XX]=Fabric Color Code: CQ=Polar White, **F]=Black, **FN=Satin

(X)=Weathershield Finish Code: B=Polar White, R=Champagne, P=Silver, U=Black

** Add \$30 to each length.

* Replacement fabrics are non returnable.

Note: Order fabrics by SlideTopper size not fabric size. Fabrics are approximately 5" shorter than stated SlideTopper size.

HARDWARE**ORDER NUMBER**

9800018.401(X)	Tall
9800018.402(X)	Short

REPLACEMENT FABRIC DISPENSER BOX - 50 FT. CONTINUOUS ROLL

T3106802FJ.600	50' x 47.5" Black
T3106802CQ.600	50' x 47.5" White

(X)=Hardware Finish Code: B=Polar White, R=Champagne, S=Satin, U=Black

DELUXE SLIDETOPPER™ AWNINGS

SlideTopper | Vinyl

DELUXE SLIDETOPPER

Vinyl Fabric, Vinyl weathershield

SIZE	FRTA VINYL WEATHERSHIELD	REPLACEMENT FABRICS*
66"	98001[XX].066(X)	B3106802[XX].066
72"	98001[XX].072(X)	B3106802[XX].072
78"	98001[XX].078(X)	B3106802[XX].078
84"	98001[XX].084(X)	B3106802[XX].084
90"	98001[XX].090(X)	B3106802[XX].090
96"	98001[XX].096(X)	B3106802[XX].096
102"	98001[XX].102(X)	B3106802[XX].102
108"	98001[XX].108(X)	B3106802[XX].108
114"	98001[XX].114(X)	B3106802[XX].114
120"	98001[XX].120(X)	B3106802[XX].120
126"	98001[XX].126(X)	B3106802[XX].126
132"	98001[XX].132(X)	B3106802[XX].132
138"	98001[XX].138(X)	B3106802[XX].138
144"	98001[XX].144(X)	B3106802[XX].144
150"	98001[XX].150(X)	B3106802[XX].150
156"	98001[XX].156(X)	B3106802[XX].156
162"	98001[XX].162(X)	B3106802[XX].162
168"	98001[XX].168(X)	B3106802[XX].168
174"	98001[XX].174(X)	B3106802[XX].174
180"	98001[XX].180(X)	B3106802[XX].180
186"	98001[XX].186(X)	B3106802[XX].186
192"	98001[XX].192(X)	B3106802[XX].192

[XX]=Fabric Color Code: CQ=Polar White, **F]=Black, **FN=Satin

(X)=Finish Color Code: B=Polar White, R=Champagne, P=Silver, U=Black

** Add \$30 to each length.

* Replacement fabrics are non returnable.

Note: Order fabrics by SlideTopper size not fabric size. Fabrics are approximately 5" shorter than stated SlideTopper size.

HARDWARE**ORDER NUMBER**

9800018.401(X)	Tall
9800018.402(X)	Short

REPLACEMENT FABRIC DISPENSER BOX - 50 FT. CONTINUOUS ROLL

T3106802FJ.600	50' x 47.5" Black
T3106802CQ.600	50' x 47.5" White

(X)=Hardware Finish Code: B=Polar White, R=Champagne, S=Satin, U=Black

REPLACEMENT FABRICS

Measure from Awning Center Arm to Center Arm

ELITE 9000™

Acrylic fabric only*

SIZE	ORDER NUMBER
8'	B830314.[XX]08
9'	B830314.[XX]09
10'	B830314.[XX]10
11'	B830314.[XX]11
12'	B830314.[XX]12
13'	B830314.[XX]13
14'	B830314.[XX]14
15'	B830314.[XX]15
16'	B830314.[XX]16
17'	B830314.[XX]17
18'	B830314.[XX]18
19'	B830314.[XX]19
20'	B830314.[XX]20
21'	B830314.[XX]21
22'	B830314.[XX]22
23'	B830314.[XX]23
24'	B830314.[XX]24
25'	B830314.[XX]25

[XX]=Fabric Color Code: BJ=Teal, CM=Forest Green, BR=Blue, BS=Sand, BQ=Burgundy, BT=Black/Grey

* Does not include weathershield.
Fabrics are 9" less than size stated
Note: Fabrics are non-returnable

8500®

With Polar White Vinyl Weathershield***

SIZE	ORDER NUMBER
8'	B3108049(XX).408
9'	B3108049(XX).409
10'	B3108049(XX).410
11'	B3108049(XX).411
12'	B3108049(XX).412
13'	B3108049(XX).413
14'	B3108049(XX).414
15'	B3108049(XX).415
16'	B3108049(XX).416
17'	B3108049(XX).417
18'	B3108049(XX).418
19'	B3108049(XX).419
20'	B3108049(XX).420
21'	B3108049(XX).421
22'	B3108049(XX).422
23'	B3108049(XX).423
24'	B3108049(XX).424
25'	B3108049(XX).425

[XX]=Fabric Color Code: NR=Onyx, NS=Sandstone, NU=Bark, NV=Maroon, NW=Meadow Green, NT=Azure, **FG=Race Flag, **FM=Rodeo,

*** Use B3108056[].408 through .425 for fabrics that take a metal weathershield. The metal weathershield is not included with this replacement fabric.
* Fabrics approximately 9" less than awning size
** Race Flag & Rodeo - Add \$25 to each length

ELITE™ WINDOW AWNING

Acrylic fabric only*

SIZE	ORDER NUMBER
30"	B83037(XX).030
36"	B83037(XX).036
42"	B83037(XX).042
48"	B83037(XX).048
54"	B83037(XX).054
60"	B83037(XX).060
66"	B83037(XX).066
72"	B83037(XX).072
78"	B83037(XX).078
84"	B83037(XX).084
90"	B83037(XX).090
96"	B83037(XX).096
108"	B83037(XX).108
114"	B83037(XX).114
120"	B83037(XX).120
132"	B83037(XX).132
138"	B83037(XX).138
144"	B83037(XX).144
156"	B83037(XX).156

[XX]=Fabric Color Code: BJ=Teal, CM=Forest Green, BR=Blue, BS=Sand, BQ=Burgundy, BT=Black/Grey

* Does not include weathershield.
Fabrics are 9" less than size stated
Note: Fabrics are non-returnable

SUNCHASER®

Vinyl Summer Shade single-sided fabric

SIZE	ORDER NUMBER
8'	B3105699(XX).080
9'	B3105699(XX).098
10'	B3105699(XX).106
11'	B3105699(XX).114
12'	B3105699(XX).122
13'	B3105699(XX).130
14'	B3105699(XX).148
15'	B3105699(XX).155
16'	B3105699(XX).163
17'	B3105699(XX).171
18'	B3105699(XX).189
19'	B3105699(XX).197
20'	B3105699(XX).205
21'	B3105699(XX).213

[XX]=Fabric Color Code: GU= Bamboo, GV= Bark, GP=Blue Steel, HE=Cranberry, GS= Meadow Green, GW= Flint

Fabrics are 11" less than size stated

Note: Fabrics are non-returnable

DELUXE PLUS™ WINDOW AWNING

Vinyl with Polar White Vinyl Weathershield***

SIZE	ORDER NUMBER
30"	B3105194(XX).030
36"	B3105194(XX).036
42"	B3105194(XX).042
48"	B3105194(XX).048
54"	B3105194(XX).054
60"	B3105194(XX).060
66"	B3105194(XX).066
72"	B3105194(XX).072
78"	B3105194(XX).078
84"	B3105194(XX).084
90"	B3105194(XX).090
96"	B3105194(XX).096
108"	B3105194(XX).108
120"	B3105194(XX).120
132"	B3105194(XX).132
144"	B3105194(XX).144

[XX]=Fabric Color Code: NR=Onyx, NS=Sandstone, NU=Bark, NV=Maroon, NW=Meadow Green, NT=Azure, FJ=Black, CQ=White, **FG=Race Flag, **FM=Rodeo

*** Use B83078[],.030 through .144 for fabrics that take a metal weathershield. The metal weathershield is not included with this replacement fabric.

* Fabrics approximately 9" less than awning size

** Race Flag and Rodeo Fabric - Add \$25 to each length

WEATHERPRO

Acrylic fabric

SIZE	ORDER NUMBER
12'	B3109893(XX).012
13'	B3109893(XX).013
14'	B3109893(XX).014
15'	B3109893(XX).015
16'	B3109893(XX).016
17'	B3109893(XX).017
18'	B3109893(XX).018
19'	B3109893(XX).019
20'	B3109893(XX).020
21'	B3109893(XX).021

[XX]=Fabric Color Code: BJ=Teal, CM=Forest Green, BR=Blue, BS=Sand, BQ=Burgundy, BT=Black/Grey

Fabrics are 9" less than size stated

Note: Fabrics are non-returnable

UNIVERSAL AND HEAVY DUTY HARDWARE SETS

Hardware, Straight and Curved Sides

STRAIGHT HARDWARE

- Straight side hardware is available in Silver, Polar White, Black or Champagne
- Curved hardware is available in Satin Aluminum only
- A set of Universal Hardware includes Left and Right Arms, Rafter Arms, Adjustable Arms, Top and Bottom Brackets and all required mounting screws
- Heavy-Duty (H.D.) Hardware can be ordered for any size 9000™, 8500™ or Sunchaser awning but is required for awnings 22' long and longer.

ORDER NUMBER FOR 9000, 8500, SUNCHASER

FOR STRAIGHT SIDE VEHICLES

8273000.401P	Silver, Tall
8273000.402P	Silver, Short
8273000.408P	Silver, Tall/Short
8273000.401B	Polar White, Tall
8273000.402B	Polar White, Short
8273000.408B	Polar White, Tall/Short
8273000.401U	Black, Tall
8273000.402U	Black, Short
8273000.408U	Black, Tall/Short
8273000.401R	Champagne, Tall
8273000.402R	Champagne, Short
8273000.408R	Champagne, Tall/Short
8273000.501P	H.D. Silver, Tall
8273000.502P	H.D. Silver, Short
8273000.501B	H.D. Polar White, Tall
8273000.502B	H.D. Polar White, Short
8273000.501U	H.D. Black, Tall
8273000.502U	H.D. Black, Short
8273000.501R	H.D. Champagne, Tall
8273000.502R	H.D. Champagne, Tall

FOR CURVED SIDE VEHICLES

838100D0(X)

(X)=Finish Color Code: B=Polar White,
R=Champagne, P=Silver, U=Black

HARDWARE

OPTIONAL INSTALLATION KIT

3314573.001	Stand off spacer for top bracket
3109623.550	Same as above but in quantities of 50
3104781.004	Bottom stand off bracket

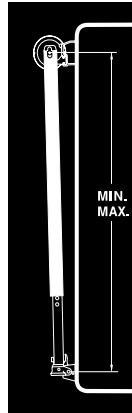

-001

Standard Straight Side

For all straight, flat sided RVs with floor line to awning rail dimensions 76" and over.

Main Arm Length: 73"

ORDER NUMBER

8273000.401(X) STR Tall
74-5/8" min., 88-1/8" max.



-002

Short Straight Side

For all straight, flat sided RVs with floor line to awning rail dimensions between 69" and 76". Executive, Pioneer, Super Coach, Kings Highway, Landau, Apollo, Pace Arrow, American Clipper, Honey and others. Main Arm Length: 61"

ORDER NUMBER

8273000.402(X) STR Short
62-5/8" min., 76-1/8" max.



-004

Curved Roof Straight Side

For flat sided RVs with awning rails along curved roofs. 1986 Argosy, Superior, Avco, Blue Bird, Chinook, Newell, Revcon, Gran Slam, Travel Queen Mini (curved roof) 1984 if newer Champion Flagship and converted buses with same roof curvature. Main Arm Length: 70"

ORDER NUMBER

838100D004 Curved
72-1/4" min., 79" max.



-005

Sportscoach (with curved side) and Vacationer Mini

Main Arm Length: 76"

ORDER NUMBER

838100D005 Curved
83-3/8" min., 85-5/8" max.



-006

GMC/WMC

Main Arm Length: 66"

ORDER NUMBER

838100D006 Curved
73-5/8" min., 75-1/8" max.



-013

Cabana, Winnebago Warrior, Itasca Spectrum, Leocraft, Big Foot and Automate-Royal, Van Guard

Main Arm Length: 83"

ORDER NUMBER

838100D013 Curved
70-1/4" min., 74" max.



-014
Avion and Avion Mini
London-aire 5th Wheel
Main Arm Length: 70"

ORDER NUMBER
838100D014 Curved
75-1/8" min., 78-7/8" max.



-015
Airstream and Argosy
(through 1985)
Main Arm Length: 76"

ORDER NUMBER
838100D015 Curved
75-5/8" min., 81-5/8" max.



-016
Silver Streak (1969 and
newer) and Streamline
Main Arm Length: 76"

ORDER NUMBER
838100D016 Curved
74-5/8" min., 81-3/8" max.

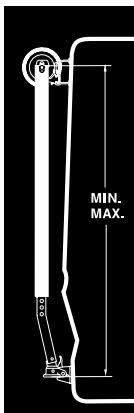

-017
Born Free Mini Sunraider-
Classic
Main Arm Length: 64"

ORDER NUMBER
838100D017 Curved
838100D638B Polar White
71-3/8" min., 75-1/8" max.



-022
Travco Lesprit, 1979
Winnebago Travel Trailers,
Southwind (Eagle) and Pace
Arrow (Eleganza) Winnebago
621, Itasca Sundancer
(See also -029)
Main Arm Length: 64"

ORDER NUMBER
838100D022 Curved
71-5/8" min., 74-5/8" max.



-024
Chevy Trans Van,
Transmaster (GBX)
Winnebago Lesharo and
Itasca Phasar Frontier,
London-aire Mini, Eldorado
Forenza
Main Arm Length: 62-1/4"

ORDER NUMBER
838100D024 Curved
64" min., 71-1/2" max.



-027
Brougham Travel Van
(‘K’, ‘R’ or ‘X’ Body Only),
Champion-Transtar and
Champion-Telstar, Eldorado
(wide body)
Main Arm Length: 61"

ORDER NUMBER
838100D027 Curved
67-1/4" min., 71" max.



-029
Winnebago Elandan
(1986 and older), Itasca
Windcruiser (1986 and
older), Winnebago 621,
and Itasca Sundancer
Main Arm Length: 61"

ORDER NUMBER
838100D029 Curved
71-1/4" min., 72" max.

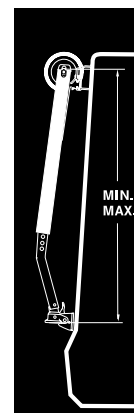

-034
1987 and newer.
Winnebago Elandan and
Itasca Windcruiser
Main Arm Length: 59"

ORDER NUMBER
838100D034 Curved
66-1/4" min., 70" max.

AWNING ACCESSORIES | OPTIMA TENSION RAFTER SYSTEM

Accessories/Rafter System

WEATHERPRO WIND SENSOR NO. 3310290.006	CRADLE SUPPORT KIT NO. 930061 1 per pkg.	SLIDER ASSEMBLY NO. 830463P 1 per pkg.	HANGER AWN™ NO. 930037 7 per pkg.	COUPLER PINS NO. 930006 2 per pkg.	CRANK TOOL NO. 3310783.000 1 per pkg.
RIVET, SEMI-TUBE 1/4" x 1-1/2" NO. 143002P041 2 per pkg.	RIVET, SEMI-TUBE 3/16" x 1-1/8" NO. 143002P051 2 per pkg.	RIVET, SEMI-TUBE 1/4" x 2.56" NO. 143002P058 2 per pkg.	ADJUSTMENT KNOBS NO. 930008 2 per pkg.	RIVET, POP 3/16" x 3/8" NO. 308171P022 6 per pkg.	TRAVEL LOCK NO. 3313343.000 1 per pkg.
DOOR EDGE GUARD NO. 3104745P009 1 per pkg.	SLIDER CATCH ASSEMBLY NO. 830472P002 2 per pkg.	PULL STRAP HANGER HOOK NO. 3107025P003 1 per pkg.	PUSH BUTTON ASSEMBLY NO. 830023P001 2 per pkg.	TRAVEL LOCKS NO. 930041 2 per pkg.	WINDOW AWNING LOCK KIT 3"= 930024 2"= 930006 2 per pkg.
RIVET, SEMI-TUBE 1/4" x 1-3/8" NO. 143002P053 6 per pkg.	46" AWNING PULL ROD NO. 830152.102 1 per pkg.	RIVET, SEMI-TUBE 5/16" x 2.59" NO. 143002P059 6 per pkg.	RIVET, OSCAR 3/16" x 1" NO. 113008P 6 per pkg.	DOOR GUARD NO. 930004 1 per pkg.	
DELUXE HANDLE NO. 830644 1 per pkg.	PULL STRAP NO. 940001 1 per pkg.	28" PULL STRAP NO. 3307834.006 1 per pkg.	TALL WINDOW STRAP EXT NO. 3107214.003	LOCK PINS NO. 930024 2 per pkg.	

OPTIMA TENSION RAFTER SYSTEM

Acrylic fabric, Metal Weathershield

- Supports and stabilizes the awning – open or closed
- Keeps canopy tensioned
- Provides ground support when the awning is in the patio position
- Easy to mount and operate
- Completely self-storing
- Fits any brand of automatic roll-up awning
- Storage cradle lifts and supports the rolled-up awning for travel



Optima Tension Rafter System Includes:

- Self-adjusting tension rafter/storage cradle
- Center ground support

Available as a complete system in one attractive package or purchase separately.

ORDER NUMBER

930042.000	Tension Rafter - Satin
930043.000	Ground Support - Satin
930039.500(X)	Optima System
930042.500(X)	Tension Rafter
930043.500(X)	Ground Support
930042.500(X)	Tension Rafter

(X)=Hardware Finish Code: B=Polar White, S=Satin, U=Black

COMMON REPLACEMENT PARTS

TORSIONS

3108399.035(X)	RH Std. Torsion for 8500/9000
3108398.029(X)	RH HD* Torsion for 8500/9000
3108399.019(X)	LH Std. Torsion for 8500/9000
3108398.011(X)	LH HD* Torsion for 8500/9000
3108706.171(X)	RH Torsion for SlideTopper
3108706.189(X)	LH Torsion for SlideTopper
3309468.001(X)	RH Torsion for Window Awning 78" down
3309467.003(X)	LH Torsion for Window Awning 78" down
3309464.000(X)	RH Torsion for Window Awning 84" up
3309465.007(X)	LH Torsion for Window Awning 84" up
3108709.761(X)	RH Torsion for Sunchaser
3108709.779(X)	LH Torsion for Sunchaser

GEARED

3316546.200B	Tall, Gear Drive Conversion Kit, White
3316546.200U	Tall, Gear Drive Conversion Kit, Black
3316546.100B	Short, Gear Drive Conversion Kit, White
3316546.100U	Short, Gear Drive Conversion Kit, Black

Note: HD torsions only used on steel roller tubes 18' and longer. Aluminum tubes use standard torsions on any size.

(X)=Finish Color Code: P=Silver, B=Polar White, U=Black, R=Champagne

SYSTEMS REPLACEMENT FABRICS

Don't have a Dometic awning but want to have Dometic quality in a replacement fabric? It's not a problem. Dometic offers a full range of stylish fabrics in woven acrylic or durable vinyl to match your current hardware. Keep your hardware, but refresh or repair your fabric with genuine Dometic replacement awning fabrics. We can create the perfect replacement fabric for your RV.

See page 31-32 for instructions about measuring your awning for replacement.

NOTE: Use B3104936[XX].X08 through .X13 and .X22 and .X25 for fabric color.

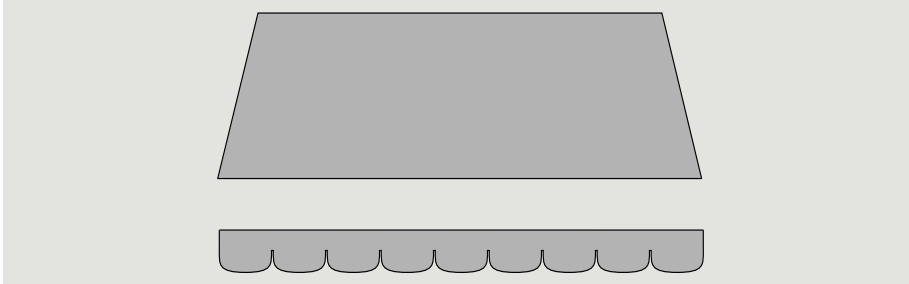

CUSTOM FABRICS

Vinyl fabric*

SIZE	ORDER NUMBER
8'	B3311634[XX].(X)08
9'	B3311634[XX].(X)09
10'	B3311634[XX].(X)10
11'	B3311634[XX].(X)11
12'	B3311634[XX].(X)12
13'	B3311634[XX].(X)13
14'	B3311634[XX].(X)14
15'	B3311634[XX].(X)15
16'	B3311634[XX].(X)16
17'	B3311634[XX].(X)17
18'	B3311634[XX].(X)18
19'	B3311634[XX].(X)19
20'	B3311634[XX].(X)20
21'	B3311634[XX].(X)21
22'	B3311634[XX].(X)22
23'	B3311634[XX].(X)23
24'	B3311634[XX].(X)24
25'	B3311634[XX].(X)25

[XX]=Fabric Color Code: NR=Onyx, NS=Sandstone, NU=Bark, NV=Maroon, NW=Meadow Green, NT=Azure, **FG=Race Flag, **FM=Rodeo

** Race Flag & Rodeo Fabric - Add \$25 to each length

Note: CUSTOM REPLACEMENT FABRICS MAY NOT BE RETURNED. When ordering, use FACTORY DEALER DIRECT Replacement Awning Fabric Order Form NUMBER OS-1589 and measure fabric edge to fabric edge carefully

UNIVERSAL FABRICS

Vinyl fabric*

SIZE	ORDER NUMBER
14'	B3314989[XX].(X)14
15'	B3314989[XX].(X)15
16'	B3314989[XX].(X)16
17'	B3314989[XX].(X)17
18'	B3314989[XX].(X)18
19'	B3314989[XX].(X)19
20'	B3314989[XX].(X)20
21'	B3314989[XX].(X)21

[XX]=Fabric Color Code: NR=Onyx, NS=Sandstone, NU=Bark, NV=Maroon, NW=Meadow Green, NT=Azure, **FG=Race Flag, **FM=Rodeo

** Race Flag & Rodeo Fabric - Add \$25 to each length

Note: CUSTOM REPLACEMENT FABRICS MAY NOT BE RETURNED. When ordering, use FACTORY DEALER DIRECT Replacement Awning Fabric Order Form NUMBER OS-1589 and measure fabric edge to fabric edge carefully



AWNING INSTALLATION MEASURING

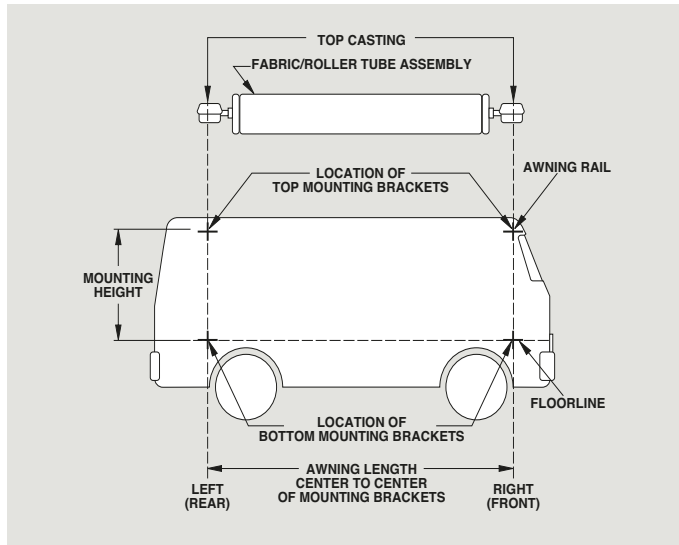

PATIO AWNINGS

1. When installing a new patio awning on a recreational vehicle, the location of windows, doors, storage compartments, and trim must be considered so the awning will not block or obstruct them. The floor line and solid structural members must be located for proper and secure mounting of hardware.
2. The true awning length is obtained by measuring between top casting to top casting, center-to-center (see illustration).
3. The two bottom mounting brackets should be positioned directly in line with the floor line of the vehicle. Make sure the center-to-center distance between the two bottom mounting brackets is exactly the same as the distance between the two top mounting brackets and the awning length (see illustration).
4. When ordering replacement fabrics or roller tubes, specify the center-to-center measurement between the top casting and NOT the length of the fabric or roller tube (see illustration). When ordering new awnings, specify the length to nearest foot, not to a fraction of a foot.

Dometic produces special length awnings, for example: 10' 8", 14' 6", 16' 6", and 19' 6". When ordering fabric or roller tubes for these sizes, be sure of the measurement between the center of the top casting to center of top casting. For total overall awning mounting length, add 3 inches to the center-to-center measurement between the top castings.

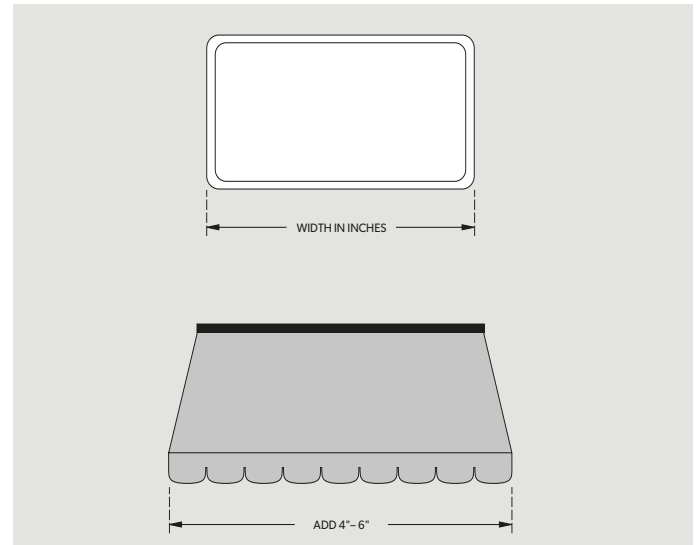

WINDOW AWNINGS

1. When installing window awnings on a recreational vehicle, first measure the overall width of each window frame.
2. The awning length is obtained by adding 4" to 6" to the overall width of the window frame.

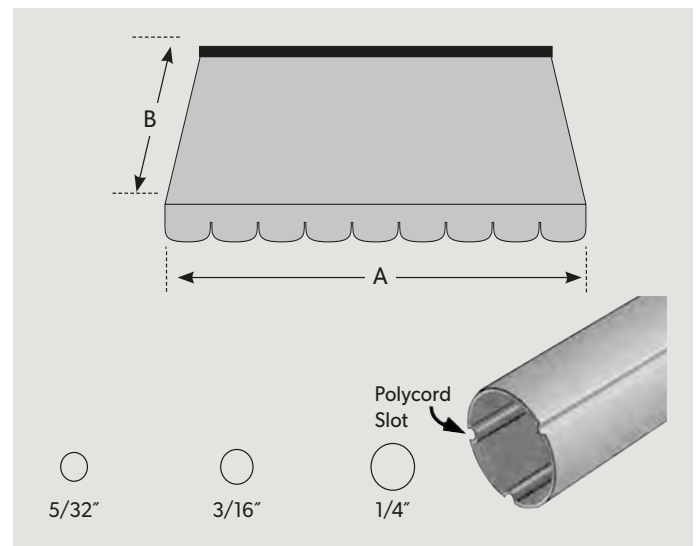

UNIVERSAL VINYL REPLACEMENT AWNING FABRICS*

Dometic can cut fabric for any awning made by other manufacturers.

1. Measure length of fabric end-to-end (A).

Note: Give us the exact measurement of your old fabric length – not including awning hardware. If brand is a Carter Awning, please also specify width of fabric (B).

2. Determine the diameter of polycord at roller tube. Polycord is sewn inside the fabric. Cut sections of your old cord and compare with diameters shown below.

*Other than A&E Awnings

WEATHERPRO | 9100 POWER | 9100 MANUAL AWNINGS

MEASUREMENTS

How to determine which model of hardware you can use.

Step #1. Measure from top of door to the awning rail. This distance will tell you if you have enough room to install a WeatherPro and Power Awning.

a. These minimums needed to use STANDARD hardware

(1) Under 6" - advisable not to use Power Awning, edge of door will scrape fabric

(2) Need 6" to install Power Awning with vinyl weathershield

(3) Need 7" to install Power Awning with metal weathershield

Note: Add 2" to the minimum needed if door is at or near center of awning*

b. These minimums are needed to use Basement hardware

(1) Need 11" to install Power Awning with vinyl weathershield

(2) Need 12" to install Power Awning with metal weathershield

Note: Add 2" to the minimum needed if door is at or near center of awning*

Step #2. Want to know how high roller will be from the ground in the extended/out position? Do the math:

a. Measure distance from ground to awning rail () minus 18" = () this is the distance roller will be from ground on Standard hardware*

b. Measure distance from ground to awning rail () minus 36" = () this is the distance roller will be from ground on Basement and 5th Wheel hardware**

Knowing the above measurements will allow you to make the correct choice as to which model of hardware you want to use on your Power Awning installation.

*Must have minimum of 6" door to rail to use Standard

**Must have minimum of 11" door to rail to use Basement. Center-to-center measurement between the top castings.

SPECIFICATIONS

Information you should know about the WeatherPro and Power Awning.

1. Extension when fully extended: 8 feet
2. Lengths available: from 12 to 21 feet in one foot increments
3. Length measured: from center of arm to center of arm
4. Width of arm: 3" (1 1/2": on each side of center)
5. Length of hardware back channel:
 - a. Standard hardware, 65 1/2"
 - b. Basement hardware, 62 1/4"
6. Depth of arm closed: 3 1/4"
7. Bottom bracket location from awning rail:
 - a. Standard hardware, 66"
 - b. Basement hardware, 63" (with extensions add 15")
8. Pitch of fabric when fully open:
 - a. Standard hardware, 13 degrees
 - b. Basement and 5th Wheel hardware, 20 degrees
9. Awning roller tube distance below awning rail when fully open:
 - a. 18" when using Standard hardware
 - b. 36" when using Basement hardware

Example: Awning rail is 110" from ground...

 - with Standard hardware awning roller tube will be 92" (7' 8")
 - with Basement hardware awning roller tube will be 74" (6' 2")

ACRYLIC SHADOW COLORS - DOUBLE-SIDED



BLUE
Color Code: BR



TEAL
Color Code: BJ



BURGUNDY
Color Code: BQ



FOREST GREEN
Color Code: CM



SAND
Color Code: BS



BLACK & GRAY
Color Code: BT

VINYL SUMMER SHADE COLORS - SINGLE-SIDED



CRANBERRY
Color Code: HE



FLINT
Color Code: GW



BARK
Color Code: GV



MEADOW GREEN
Color Code: GS



BLUE STEEL
Color Code: GP

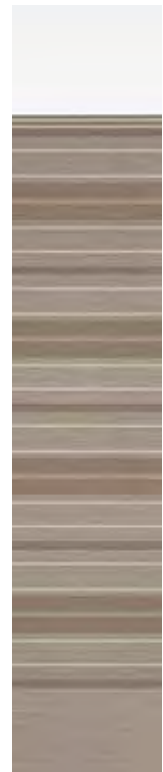

BAMBOO
Color Code: GU

VINYL LINEN FADE COLORS - DOUBLE-SIDED



SANDSTONE
Color Code: NS

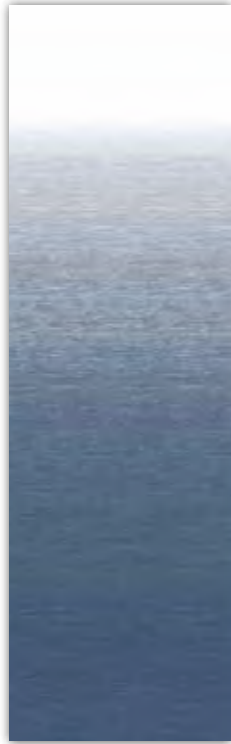

AZURE
Color Code: NT



BARK
Color Code: NU



MAROON
Color Code: NV

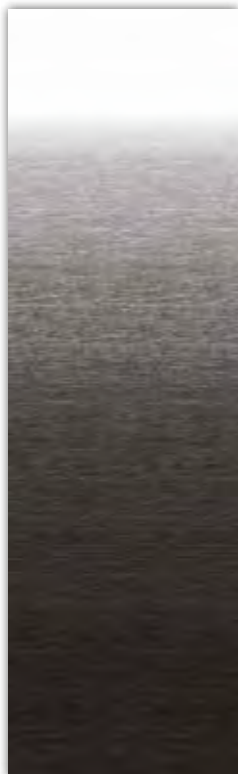

ONYX
Color Code: NR

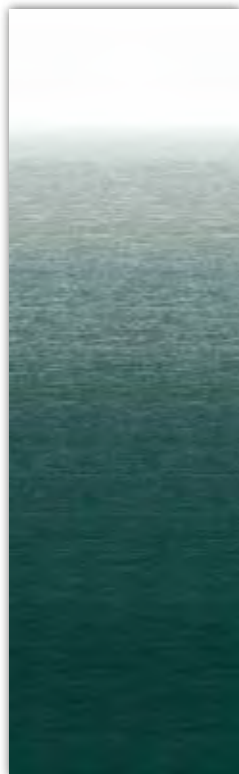

MEADOW GREEN
Color Code: NW

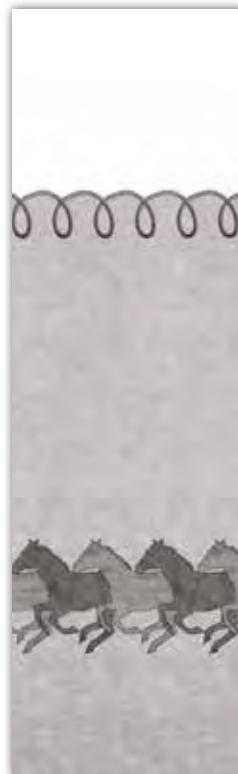

RODEO
Color Code: FM



RACE FLAG
Color Code: FG

RV AWNING APPLICATION CHART

	TYPE	FABRIC	SIZES	WEATHERSHIELD	HARDWARE	APPLICATIONS
PATIO						
Weatherpro Awning	Automatic	Double-sided Vinyl Or Woven Acrylic	12' - 21'	Metal	Black, Champagne, Polar White or Satin	Motorhomes, Fifth Wheels, Travel Trailers
9100 Awning	Automatic or Manual	Single-sided (Summershade) or Double-sided (Fade) Vinyl or Woven Acrylic	10' - 21'	Vinyl Or Metal	Polar White, Silver, Black, or Champagne	Fifth Wheels, Travel Trailers, Motorhomes
9000™ Awning	Manual	Woven Acrylic	8' - 25'	Metal	Universal Hardware, Silver, Polar White, Black or Champagne	Motorhomes, Travel Trailers, Fifth Wheels, Mini-Motorhomes, Truck Campers
8500® Awning	Manual	Double-sided Vinyl	8' - 25'	Polar White Vinyl or Metal	Universal Hardware Silver, Polar White, Black or Champagne	Motorhomes, Travel Trailers, Fifth Wheels, Mini-Motorhomes, Truck Campers
Sunchaser®	Manual	Single-sided Vinyl	8' - 21'	White Vinyl	Universal Hardware Silver, Polar White, Black or Champagne	Motorhomes, Travel Trailers, Fifth Wheels, Mini-Motorhomes, Truck Campers
9100 Power Channel	Automatic	Double-sided Vinyl	10' - 21'	Vinyl or Metal	Silver, Polar White, Black or Champagne	Fifth Wheels, Travel Trailers, Motorhomes
CASE/BAG						
9500	Automatic or Manual	Double-sided Vinyl	8', 10', 12', 13', 15', 16'	Case	Included	Motorhomes, Travel Trailers, Fifth Wheels, Mini-Motorhomes
Trim Line®	Manual (Bag)	Double-sided Vinyl	7' - 12'	Vinyl Bag Polar White	Self-Contained	Fold-Down Campers, Vans, Mini-Camper Vans, Truck Campers
DOME AWNING						
Cabana	Manual	Vinyl	7', 9', 11', 13'			Fold-Down Campers, Vans
WINDOW						
Elite™	Manual	Woven Acrylic	Standard 36" - 156" Tall 30" - 156"	Metal	Black, Champagne, Polar White or Silver	Motorhomes, Fifth Wheels, Travel Trailers
Deluxe Plus™	Manual	Vinyl	30" - 156" Tall 30" - 156"	Metal or Vinyl	Black, Champagne, Polar White or Silver	Motorhomes, Fifth Wheels, Travel Trailers
DOOR						
Oasis™ II	Manual	Woven Acrylic or White Vinyl		All Metal Case	Self-supporting	Motorhomes, Fifth Wheels, Travel Trailers
Elite Oasis™ II	Automatic	Woven Acrylic or White Vinyl		All Metal Case	Self-supporting	Motorhomes, Fifth Wheels, Travel Trailers
SLIDETOPPER™						
Full Cover	Automatic	Vinyl	66" - 192"	Metal Case	45° or 90° - Black, Champagne, Polar White or Silver	Mini-Motorhomes, Fifth Wheels, Travel Trailers
Elite	Automatic	Vinyl	66" - 192"	Metal	45° or 90° - Black, Champagne, Polar White or Silver	Mini-Motorhomes, Fifth Wheels, Travel Trailers
Deluxe	Automatic	Vinyl	66" - 192"	Vinyl	45° or 90° - Black, Champagne, Polar White or Silver	Mini-Motorhomes, Fifth Wheels, Travel Trailers

PRODUCT SPECIFICATION CHART

	PATIO	WINDOW	DOME	DOOR	SLIDEOUT	VINYL CANOPY FABRIC	ACRYLIC CANOPY FABRIC	SINGLE-SIDED FABRIC	DOUBLE-SIDED FABRIC	METAL WEATHERSHIELD	VINYL WEATHERSHIELD	POWER HARDWARE	UNIVERSAL HARDWARE	CASE OR BOX HARDWARE	MANUAL HARDWARE	SIZES AVAILABLE	RAIN SHED	WIND SENSOR	REMOTE CONTROL	WEIGHT
Weatherpro	•					•	•		•	•		•				12' - 21'	•	•	•	110 - 132 lbs.
9100 Power	•					•	•		•	•	•	•				10' - 21'	•		•	43.5 - 68.5 lbs.
9100 PowerChannel	•						•		•	•	•					10' - 21'				46 - 90 lbs.
9100 Manual	•					•	•	•	•	•	•				•	10' - 21'				45 - 63 lbs.
9000™	•						•			•			•			8' - 25'				65 - 130 lbs.
8500®	•					•				•			•			8' - 25'				65 - 130 lbs.
Sunchaser®	•					•		•			•		•			8' - 21'				54 - 90 lbs.
9500	•					•			•			•		•		8', 10', 12', 13', 15', 16'	•	•	•	55 - 102 lbs.
Trim Line®	•					•			•							7' - 12'				18 - 29 lbs.
Cabana			•													7', 9', 11', 13'				23 - 26 lbs.
Elite™		•					•		•	•						36" - 156"				8 - 33.5 lbs.
Deluxe Plus™		•				•			•		•					30" - 144"				6.5 - 21.5 lbs.
Oasis™ II				•		•	•		•					•		48" & 56"				23 - 26.5 lbs.
Elite Oasis™ II				•		•	•		•			•		•		48" & 56"				23 - 26.5 lbs.
SlideTopper™ FC					•	•				•	•					Length x 44"				25 - 65 lbs.
Elite SlideTopper™					•	•				•						Length x 44"				25 - 65 lbs.
Deluxe SlideTopper™				•	•					•						Length x 44"				25 - 65 lbs.

CLIMATE

FOOD & BEVERAGE

HYGIENE & SANITATION

SAFETY & SECURITY



EMBRACE THE FRESH AIR
PATIO ROOMS

TRIM LINE® | CABANA

Case/Bag/Screen Room | Manual | Vinyl

TRIM LINE BAG AWNING

- Polycord sewn in - bag slides into awning rail
- All parts stow in zippered bag
- Adjustable support poles and click lock poles
- 7-foot extension
- Length = end of bag to end of bag

SIZE	ORDER NUMBER
------	--------------

7'	944[XX]07.002
8'	944[XX]08.002
9'	944[XX]09.002
10'	944[XX]10.002
11'	944[XX]11.002
12'	944[XX]12.002

[XX]=Fabric Color Code: NR=Onyx, NS=Sandstone, NV=Maroon, NT=Azure, NW=Meadow Green, NU=Bark

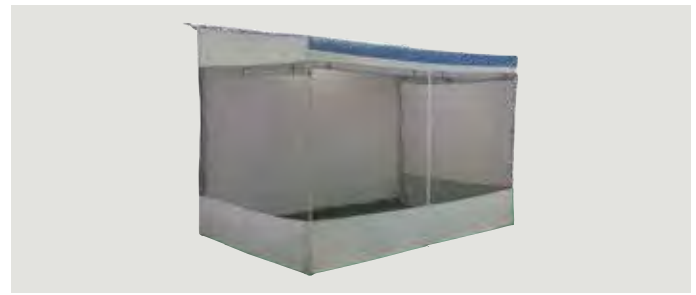

TRIM LINE SCREEN ROOM WITH PRIVACY PANELS

- Attaches with Velcro®
- Available in sizes to fit all Trim Line bag awnings
- Folds up to store in its own durable pouch

**Must purchase Trim Line bag awning separately.

SIZE	ORDER NUMBER
------	--------------

7'	947207.009
8'	947208.009
9'	947209.009
10'	947210.009
11'	947211.009
12'	947212.009

* Contact the RV manufacturer if zippered panels are required

CABANA LIGHTWEIGHT DOME AWNING

- Double the living space - porch, privacy/screen room or breezeway
- Self contained RV dome awning
- Widths of 7', 9', 11', 13'
- 8' projection gives flexibility to fit any RVer need and desire
- High domed ceiling provides ample headroom
- Heavy-duty, waterproof and fire retardant fabric
- Ground Guard 500 denier waterproof vinyl keeps the ground dry and withstands foot traffic and patio furniture
- Screen mesh panels and extra-tall wheel well skirt provide 360° protection from insects
- Roll-up shades and side doors give added privacy
- Stows on exterior of the RV, freeing up interior storage space
- White with green trim

SIZE	ORDER NUMBER
------	--------------

7'	747GRN07.000
9'	747GRN09.000
11'	747GRN11.000
13'	747GRN13.000

VERANDA ROOM

Makes the RV patio awning into a comfortable screened-in enclosure

- Can be used with power & manual awnings
- Use starter kit and additional zippered panels to create any size of room
- Standard or tall height – see “How to Measure” (below)
- Faster, easier set-up and take down – no tools needed
- 2’, 4’ and 8’ panels are available
- Super-durable fire-resistant screen fabric repels moisture, dries quickly to resist mildew
- Roll-down privacy panels are sewn in
- One-year limited warranty

1. STANDARD OR TALL? HOW TO MEASURE:

Measure distance from ground to the vehicle’s awning rail

93” to 110” = Standard Height

111” to 120” = Tall Height

2. USE THIS CHART TO DETERMINE WHICH PANELS ARE NEEDED:

EXISTING AWNING SIZE	REQUIRED COMPONENTS
8’ and 9’	Starter + 4’ panel
10’ and 11’	Starter + 4’ panel + 2’ panel
12’ and 13’	Starter + 4’ panel + 4’ panel
14’ and 15’	Starter + 8’ panel + 2’ panel
16’ and 17’	Starter + 8’ panel + 4’ panel
18’ and 19’	Starter + 8’ panel + 4’ panel + 2’ panel
20’ and 21’	Starter + 8’ panel + 8’ panel
22’ and 23’	Starter + 8’ panel + 8’ panel + 2’ panel
24’ and 25’	Starter + 8’ panel + 8’ panel + 4’ panel



ORDER NUMBER

935000.140	Starter Kit - Standard*
935002.120	2’ Panel - Standard
935004.120	4’ Panel - Standard
935008.120	8’ Panel - Standard
935000.150	Starter Kit - Tall*
935002.130	2’ Panel - Tall
935004.130	4’ Panel - Tall
935008.130	8’ Panel - Tall
3106384.005	25 pk. Fasteners**

* Starter kit includes: One left end panel, one right end panel, one door panel, skirting, wheel-well cover, hardware kit and zippered storage bag.

** Replacement Part



VERANDA SHADE

54” Height, Stakes and tie downs included

SIZE ORDER NUMBER

10’	930010.(X)10
15’	930015.(X)10

(X)= Fabric Color Code: G=Burgundy, P=Coffee, H=Blue



XTEND-A-ROOM

Expand your Sport Utility Trailer by as much as 60 square feet. After a full day of outdoor activities, nothing beats a comfortable space to kick back and relax. An XTEND-A-ROOM expands a trailer's living space with plenty of room to stretch out and revisit all of the day's adventures with friends and family.

- Two room sizes fit most sport utility trailers on the road today
- Easy-access ramp end opens for quick loading and unloading
- Adjustable support poles have ergonomically designed positive crimping locks to ensure proper fit
- Floor skirt tightly seals room to ramp gate without fasteners
- Quick bungee attachment keeps out wind and rain
- Front mounting poles fit into side pocket sleeves for a clean look
- Two stands support ramp and room securely
- Reinforced nylon seams withstand plenty of use
- Strong, rip-resistant fabric
- Weatherproof privacy panels add rain protection and prevent wicking
- Full-view screens provide a scenic view

ORDER NUMBER

954086.000 Standard, 79.5" to 86.5" H x 86"D to 91" W

954091.000 Large, 86.5" to 95.5" H x 91" D to 99" W

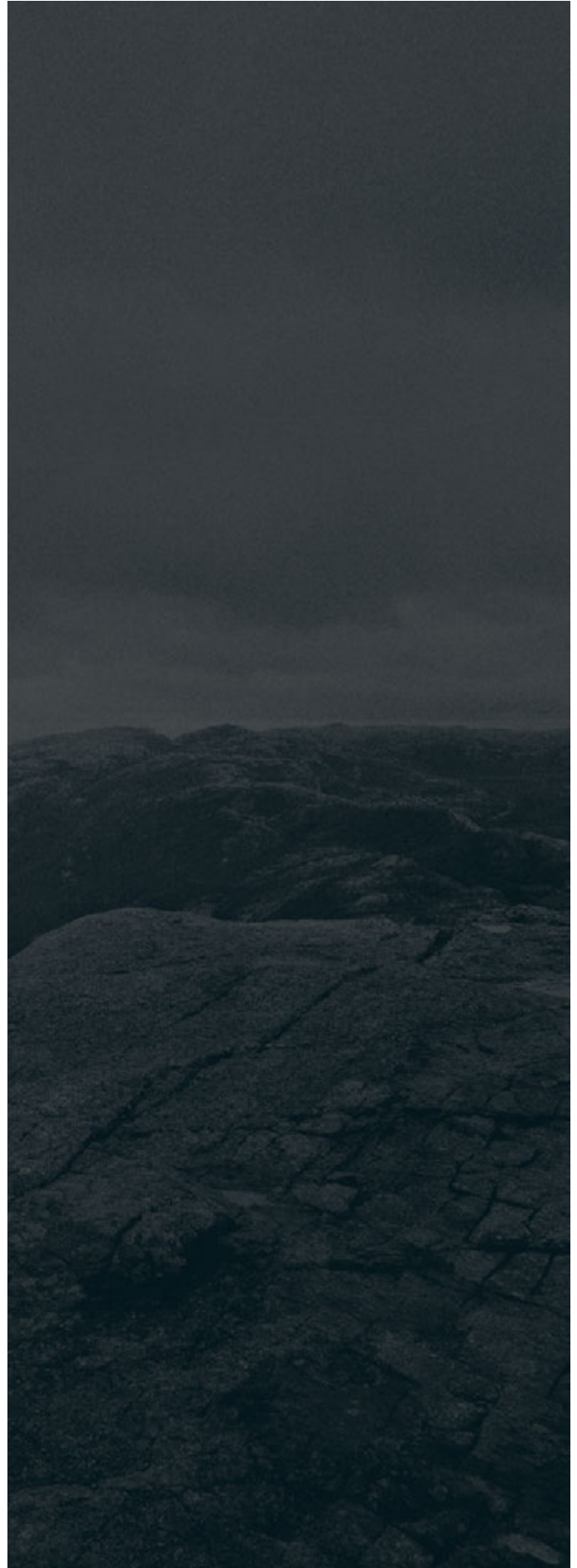



BRING FRESH AIR INSIDE
VENTILATION



MODEL 7350

- 14 fixed manual speeds or automatic variable speeds
- Reverse switch sets the fan blade direction (OUT-exhaust or IN-intake)
- Rain sensor with On/Off switch and automatic dome open/close switch
- A built-in thermostat maintains your desired comfort level

ORDER NUMBER

807350 Power Vent, Remote Control



MODEL 3350

- Three fan blade speeds (low, medium, high)
- Reverse switch (OUT-exhaust or IN-intake)
- Built-in thermostat
- Rain sensor automatically closes the dome

ORDER NUMBER

803350 Power Vent Sensor, Thermostat



MODEL 2250

- Three fan blade speeds (low, medium, high),
- Reverse switch (OUT-exhaust or IN-intake)
- Built-in thermostat

ORDER NUMBER

802250 Power Vent, Thermostat



MODEL 1250

- Three fan blade speeds (low, medium, high)
- Additional options
- White base

ORDER NUMBER

801250 Power Vent, Reverse



MODEL 1200

- Three fan blade speeds (low, medium, high)
- Manual dome lifting knob
- White base

ORDER NUMBER

801200 Power Vent, Smoke



MODEL 900

- Manual lift
- Smoke dome

ORDER NUMBER

800900 Non-Powered, Vent



MODEL 800

- Manual lift
- White dome

ORDER NUMBER

800800 Non-Powered, Vent

FEATURES	7350	3350	2250	1250	1200	900	800
Power Lift	•	•	—	—	—	—	—
Manual Lift	—	—	•	•	•	•	•
3 Speed	—	•	•	•	•	—	—
Variable Speed	•	—	—	—	—	—	—
Thermostat	•	•	•	—	—	—	—
Rain Sensor	•	•	—	—	—	—	—
Wireless Remote	•	—	—	—	—	—	—
Reverse	•	•	•	•	—	—	—



EZ-BREEZE®

- Built in rain cover provides air circulation throughout without needing to open dome
- 3 times more airflow than standard vents

ORDER NUMBER

800600	EZ-Breeze®, 12 volt, White
800601	EZ-Breeze®, 12 volt, Smoke
800500	EZ-Breeze®, Static Vent, White
800501	EZ-Breeze®, Static Vent, Smoke



UPGRADE KITS

- Kits allow you to take any Dometic 12V vent and upgrade to an array of features and functions

ORDER NUMBER

807359	Upgrade to 7350
803359	Upgrade to 3350
802259	Upgrade to 2250
801259	Upgrade to 1250

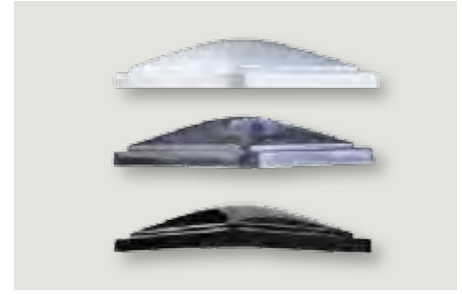

REPLACEMENT DOMES

- Flat domes available by special order.

ORDER NUMBER

K8020-09	Black Dome
K1020-00	Clear Dome
K8020-81	White Opaque Dome
K1020-19	Smoke Translucent Dome
K2020-81	White Insulated Dome
K2020-19	Smoke Insulated Dome



ULTRA BREEZE™

- Vent protection
- Patented design utilizes airfoil technology
- Blocks the rain, not the airflow: retains up to 95% airflow
- For use with all types of roof vents
- Fits standard 14"x14" vent openings
- Installs easily without any drilling
- All hardware is included.

ORDER NUMBER

U1500WH	Vent Cover, White
U1500BL	Vent Cover, Black
U1500GR	Vent Cover, Smoke
U1550WH	Bug Screen, White
U1550BL	Bug Screen, Black



POP'N LOCK VENT SCREENS

- Cleaning your screen is now a breeze
- Easily pops into your existing Dometic Fan
- No tools or screws needed
- Screen covers the screw holes
- 2/box

ORDER NUMBER

K2035-81	Vent Screen White
K2035-80	Vent Screen Off White



ENDLESS BREEZE®

- Powerful 12V portable fan
- Designed to move a large volume of air
- Attaches to pet cages to provide them cool comfort on warm days

ORDER NUMBER

O1100WH	Endless Breeze®
---------	-----------------

EXPAND EXPLORATIONS INTO OTHER SEASONS

FURNACES



SMALL FURNACE

- Available in models from 12,000 – 20,000 BTU
- Furnace Dimensions: 7" H x 12" W x 20" D
- May be mounted vertically or horizontally
- Access door and thermostat sold separately

ORDER NUMBER

32715	DC Small Furnace, 12,000 BTU
32719	DC Small Furnace, 16,000 BTU
32723	DC Small Furnace, 20,000 BTU



MEDIUM FURNACE

- Available in models from 16,000 – 35,000 BTU
- Furnace Dimensions: 7-3/8" H x 16-1/2" W x 20" D
- May be mounted vertically or horizontally
- Access door and thermostat sold separately

ORDER NUMBER

32663	DC Medium Furnace, 16,000 BTU
32668	DC Medium Furnace, 20,000 BTU
32675	DC Medium Furnace, 25,000 BTU
32684	DC Medium Furnace, 30,000 BTU
32690	DC Medium Furnace, 35,000 BTU



LARGE FURNACE

- Available in models from 35,000 – 40,000 BTU
- Furnace Dimensions: 9" H x 16-1/2" W x 20" D
- May be mounted vertically or horizontally
- Access door and thermostat sold separately

ORDER NUMBER

32650	AC Large Furnace, 35,000 BTU
32653	AC Large Furnace, 40,000 BTU
32656	DC Large Furnace, 35,000 BTU
32659	DC Large Furnace, 40,000 BTU



TRIM RINGS

- Use only when replacing an 8900 series furnace with a smaller furnace
- Trim ring option can be used to cover the opening and allow for a proper seal

ORDER NUMBER

32422	Large Furnace Trim Ring, Black
32423	Large Furnace Trim Ring, White



DIGITAL THERMOSTAT

- Operates all standard furnaces (except 2-stage) and most standard rooftop air conditioners
- Provides 7 heating and cooling functions

ORDER NUMBER

38555	White
-------	-------



MECHANICAL THERMOSTAT

- Heat only

ORDER NUMBER

32300	Black
38453	White
38452	Brown

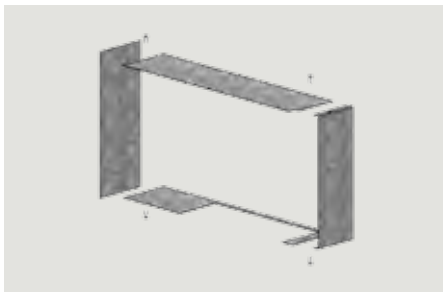

BOTTOM DISCHARGE KIT

- Use only when replacing an 8900 series furnace with a new Large series furnace where a bottom discharge system is used
- This extension kit will relocate the opening to match the 8900 location

ORDER NUMBER

32337	Large Furnace Bottom Discharge Kit
-------	------------------------------------



ACCESS DOORS

ORDER NUMBER

36129	Deluxe, White
34237	Std, Black
32344	Sm Furn, Black
32343	Sm Furn, Arctic White
30637	Med Furn, Black
30539	Med Furn, Arctic White
31861	Large Furn, Black
31845	Large Furn, Arctic White

COMMON REPLACEMENT PARTS

ORDER NUMBER

31501	Ignition Control & Adapter Board with Relay
33126	Blower Wheel & Clamp, 85
37357	Motor Kit 8531-35-III & DC89-III
33589	Motor 8531-35-I & II
32422	Large Furnace Trim Ring, Black
32423	Large Furnace Trim Ring, White
33128	85/89 Combustion Wheel Kit
34570	Electrode Assembly with Lead
32774	Motor 8525-II, PF23175Q
37358	Motor Kit 8525-III
33219	Motor Kit 85-II, 16, 20



/ REFRIGERATION
/ MOBILE COOLING
/ COOKING

FOOD BEVER



FOOD & DRINK





THE FIRST NAME IN RV REFRIGERATION
REFRIGERATION

COMPACT AND PORTABLE MODELS

RM2193

- 1.9 cubic feet capacity
- 3-way power
- Sized to replace a standard icebox
- Black frame

RM4223

- Standard rear cooling unit, ideal for pickup campers and smaller travel trailers
- 2.5 cubic feet capacity
- 3-way power
- Black frame



ORDER NUMBER

RM2193RB	Right swing, Black
RM2193LB	Left swing, Black
RM4223RB	Right swing, Black
RM4223LB	Left swing, Black

PRODUCT SPECIFICATIONS

RM2193RB

Overall Dimensions: 21" x 17 3/4" x 21 1/2"
Weight: 46 lbs.

RM4223RB

Overall Dimensions: 21" x 19 1/4" x 24"
Weight: 59 lbs.

*See our extended line of mobile coolers on page 79-84

SIX-BOTTLE WINE CHILLER

Perfectly store precious wines at just the right temperature (41°F and 68°F). Compact, practical and absolutely vibration-free with easy-to-read control panel.

- Electronic thermostat with digital temperature display
- Transparent door with magnetic lock
- Interior light and three removable grid shelves
- Drip tray for the condensation water
- Wear-free thermoelectrics with interior and exterior fan
- Storing capacity: six bottles lying (bottle length up to 12.6 inches)
- Power type: AC and DC

ORDER NUMBER

MF-6W	Six-bottle Wine Chiller
-------	-------------------------

PRODUCT SPECIFICATIONS

Dimensions: 16.3" x 10.2" x 18.5"
Weight: 16.7 lbs.





ORDER NUMBER

RM1350WIMSS	Silver Stainless
RM1350WIMBS	Black Stainless
RM1350WIM	Accepts Panels

PRODUCT SPECIFICATIONS

Overall Dimensions: 64 17/64" x 33 11/16" x 28 1/16"
 Recess Dimensions: 63 3/16" x 32- 3/4" x 26 1/16"
 Shipping Weight: 242 lbs.

Subject to change without notice.
 See page 67 for door insert panels
 See page 68 for roof and side vents
 See pages 69-71 for refrigerator replacement chart
 *Call for additional options.

ELITE 2+2 REFRIGERATORS

- A higher standard for RV refrigeration
- 12.0 cu. ft. capacity
- Pass-through, divider-less freezer section
- Automatic door lock activated by RV ignition system
- Larger and more powerful cooling unit
- Contemporary styling
- Three crispers
- Dual-action shelf guards
- Through-the-door ice water
- Optional ice maker
- 2-way power
- America's choice in full-featured RV refrigeration
- Automatic temperature control
- Defrost water drain system

	RM1350WIMSS	RM1350WIMBS	RM1350WIM
AGA/CGA Certified	•	•	•
2-Way Operation, 110V AC/LP Gas	•	•	•

CONTROL PACKAGES

	RM1350WIMSS	RM1350WIMBS	RM1350WIM
Automated Ambient Temperature	•	•	•
Eye-Level Electronic Controls	•	•	•
Standby Operation Mode	•	•	•
Automatic Ignition Locks	•	•	•

EXTERIOR FEATURES

	RM1350WIMSS	RM1350WIMBS	RM1350WIM
Platinum Stainless Steel	•		
Black Stainless Steel		•	
Offset Door Configuration	•	•	•
Residential Style Handles	•	•	•
Positive Lock System	•	•	•
Solid Steel Frame	•	•	•
Automatic Front-Frame Heater	•	•	•
CFC/HCFC-Free Foam Insulation	•	•	•

INTERIOR FEATURES

	RM1350WIMSS	RM1350WIMBS	RM1350WIM
Optional Automatic Ice Maker	•	•	•
Easy-Clean White Interior	•	•	•
Versatile Racking System™	•	•	•
Designer White-Coated Shelves	•	•	•
Sliding Freezer Bins	•	•	•
Dual Shelf Guards and Slide-Out Shelf	•	•	•
Adjustable Door Bins with Magic Fingers™	•	•	•
Halogen Interior Lighting	•	•	•
Three Crispers	•	•	•



8-SERIES REFRIGERATORS

- 3-Way Power
- 6.67 cu. ft. and 3.74 cu. ft.
- Energy efficient, Euro-style design
- Patented detachable freezer compartment provides more room for refrigerated food when needed and reduces energy consumption
- Fingertip door opening
- Energy-efficient interior LED lights
- User-friendly control panel
- Replaceable door panels
- Flexible shelving system
- Ergonomic door shelves with leakage protection

	RM8551	RML8555
AGA/CGA Certified	•	•
3-Way Operation, 110V AC, 12V DC, LP Gas	•	•

CONTROL PACKAGES

User-friendly Control Panel	•	•
-----------------------------	---	---

EXTERIOR FEATURES

Silver/Gray	•	•
Coated Sheet Steel	•	•
Positive Lock System	•	•
Automatic Front-Frame Heater	•	•
Solid Steel Frame	•	•
CFC/HCFC-Free Foam Insulation	•	•

INTERIOR FEATURES

Removable Freezer Compartment	•	•
LED Interior Light	•	•
Easy Cleaning Interior	•	•
Door with Magnetic Seal	•	•

ORDER NUMBER

RM8501RFBP	3.7 cu. ft., Small Single Door, Right Hinge, Silver
RM8551LF	4.3 cu. ft., Single Door, Left Hinge, 2 Fans, Black Frame
RM8551RF	4.3 cu. ft., Single Door, Right Hinge, 2 Fans, Black Frame
RML8555L	6.7 cu. ft., Large Single Door, Left Hinge, Black Frame
RML8555LSAF	6.7 cu. ft., Large Single Door, Left Hinge, Stainless Door
RML8555R	6.7 cu. ft., Large Single Door, Right Hinge, Black Frame
RML8555RSAF	6.7 cu. ft., Large Single Door, Right Hinge, Stainless Door

PRODUCT SPECIFICATIONS

RM8551

Recess Dimensions:	32.48" x 20.74" x 23.50"
Shipping Weight:	67 lbs.
Cubic Feet:	3.74 cu. ft. without freezer comp. 3.53 cu. ft. with freezer comp.

RML8555

Recess Dimensions:	49.17" x 20.82" x 23.58"
Shipping Weight:	100 lbs.
Cubic Feet:	6.67 cu. ft. without freezer comp. 6.32 cu. ft. with freezer comp.

Subject to change without notice.

See page 67 for door insert panels

See page 68 for roof and side vents

See pages 69-71 for refrigerator replacement chart



NEW GENERATION REFRIGERATORS – 7 CU. FT.

- 2-Way Power
- A higher standard for RV refrigeration
- 7 cubic feet of capacity
- Extra cubic foot of interior capacity
- Intuitive, self-locking door handles
- Stylish, residential appearance
- Contemporary styling
- Flush-mounted interior light
- Shelf guards
- Four interior fresh food shelves
- Versatile Racking System™
- Self-adjusting Magic Fingers™
- Eye-level, LED temperature display
- More storage!

RM3762

AGA/CGA Certified	•
2-Way Operation, 110V AC/LP Gas	•

CONTROL PACKAGES

Climate Control Cooling System	•
Automated Ambient Temperature	•
Eye-Level Electronic Controls	•
Standby Operation Mode	•

ORDER NUMBER

RM3762RB	Double Door, Right Swing
RM3762LB	Double Door, Left Swing
RM3762RSS	Double Door Silver Stainless, Right Swing
RM3762LSS	Double Door Silver Stainless, Left Swing

PRODUCT SPECIFICATIONS

Overall Dimensions: 54 3/4" x 25 5/16" x 26 1/16"
 Recess Dimensions: 53 3/4" x 23 11/16" x 24"
 Shipping Weight: 143 lbs.

EXTERIOR FEATURES

Platinum Stainless Steel	•
Black Stainless Steel	•
Offset Door Configuration	•
Residential Style Handles	•
Positive Lock System	•
Solid Steel Frame	•
Automatic Front-Frame Heater	•
CFC/HCFC-Free Foam Insulation	•

INTERIOR FEATURES

Optional Automatic Ice Maker	•
Easy-Clean White Interior	•
Versatile Racking System™	•
Designer White-Coated Shelves	•
Sliding Freezer Bins	•
Dual Shelf Guards and Slide-Out Shelf	•
Adjustable Door Bins with Magic Fingers™	•
Halogen Interior Lighting	•
Two Crispers	•
180° Door Swing	•

Subject to change without notice.

See page 67 for door insert panels

See page 68 for roof and side vents

See pages 69-71 for refrigerator replacement chart



NEW GENERATION REFRIGERATORS – 9 CU. FT.

- 2-Way Power
- A higher standard for RV refrigeration
- 9 cubic feet of capacity
- Extra cubic foot of interior capacity
- Intuitive, self-locking door handles
- Stylish, residential appearance
- Contemporary styling
- Flush-mounted interior light
- Shelf guards
- Four interior fresh food shelves
- Versatile Racking System™
- Self-adjusting Magic Fingers™
- Eye-level, LED temperature display
- More storage!

RM3962

AGA/CGA Certified	•
2-Way Operation, 110V AC/LP Gas	•

CONTROL PACKAGES

Climate Control Cooling System	•
Automated Ambient Temperature	•
Eye-Level Electronic Controls	•
Standby Operation Mode	•

EXTERIOR FEATURES

Platinum Stainless Steel	•
Black Stainless Steel	•
Offset Door Configuration	•
Residential Style Handles	•
Positive Lock System	•
Solid Steel Frame	•
Automatic Front-Frame Heater	•
CFC/HCFC-Free Foam Insulation	•

INTERIOR FEATURES

Optional Automatic Ice Maker	•
Easy-Clean White Interior	•
Versatile Racking System™	•
Designer White-Coated Shelves	•
Sliding Freezer Bins	•
Dual Shelf Guards and Slide-Out Shelf	•
Adjustable Door Bins with Magic Fingers™	•
Halogen Interior Lighting	•
Two Crispers	•
180° Door Swing	•

ORDER NUMBER

RM3962RB	Double Door, Right Swing
RM3962LB	Double Door, Left Swing
RM3962RSS	Double Door Silver Stainless, Right Swing
RM3962LSS	Double Door Silver Stainless, Left Swing
RB3962RBIMF	Double Door Ice Maker, Fan, Right Swing

RIGHT OR LEFT DOOR SWING OPTIONS

Right door swing (handle on left, hinges on right) is standard. Use product number to determine door reversing kit.

ORDER NUMBER

3851044010	Right to Left (SS & BS cannot be reversed)
------------	--

PRODUCT SPECIFICATIONS

Overall Dimensions: 63 15/16" x 25 5/16" x 26 1/16"

Recess Dimensions: 62 61/64" x 23 11/16" x 24"

Shipping Weight: 171 lbs.

Subject to change without notice.

See page 67 for door insert panels

See page 68 for roof and side vents

See pages 69-71 for refrigerator replacement chart



SUPER HYBRID REFRIGERATORS

- Hybrid technology
Top fresh food unit - absorption runs on either propane or electricity
Bottom modular drawer freezer - compressor (variable-speed technology) runs on 115VAC or 12VDC electricity
- Quick to cool down, thanks to variable compressor technology
- Bottom drawer - deep-freeze, refrigerate or "off"
- 9 cu. ft.
- Five adjustable shelves
- Two bright white LED lights
- Integrated open-door alarms and an airing position
- Control panel, hidden behind the door, backlit, with LEDs
- Premium stainless steel slides hold an oversized basket that can handle 100 lbs.

ORDER NUMBER

DMH1072LB	Super Hybrid Refrigerator - Left swing
DMH1072RB	Super Hybrid Refrigerator - Right swing



AMERICANA DMC REFRIGERATORS

- Variable speed compressor operates on 115VAC and 12VDC
- 6 or 8 cu. ft. capacity
- Flexible storage options
- Eye-level electronic controls
- LED interior light
- Adjustable freezer shelf
- Two crispers
- Doors open 180°
- Easy clean white interior
- Removable door bins
- 2-liter bottle and 1/2-gallon container door storage
- Black frame
- Positive lock door handles
- Cooling temperature range refrigerator: 30° F - 45° F
- Cooling temperature range freezer: 0° F - 14° F

ORDER NUMBER

DMC2641LB	6 cu. ft. - Left swing
DMC2641RB	6 cu. ft. - Right swing
DMC2841LB	8 cu. ft. - Left swing
DMC2841RB	8 cu. ft. - Right swing



AMERICANA PLUS REFRIGERATORS

- Eye-level automatic/manual electronic controls
- 6 or 8 cu. ft. capacity
- 2-way power with automatic LP ignition
- Climate control cooling system
- Black frame
- 180° full door swing
- High-efficiency insulation uses no CFCs or HCFCs
- Large residential style door handles lock automatically
- Bright white, easy-to-clean interior
- Lighted fresh food compartment
- Versatile Racking System™
- Meat locker and crisper compartments
- Flexible, efficient design loaded with features

DM2662RB

DM2862RB

AGA/CGA Certified	•	•
2-Way Operation, 110V AC/LP Gas	•	•

CONTROL PACKAGES

Eye-Level Electronic Controls with Automatic Electronic LP Ignition System	•	•
Standby Operation Mode	•	•

EXTERIOR FEATURES

Modern Integrated Exterior, Design Profile	•	•
Ergonomically Designed		
Positive Lock Door Handles	•	•
Climate Control Cooling System	•	•
Doors that Open 180°	•	•
CFC/HCFC-Free Foam Insulation	•	•

INTERIOR FEATURES

Beautifully Sculpted, Practical and Easy-To-Clean White Interior	•	•
Adjustable, Removable Door Bins	•	•
2-Liter Bottle and 1/2-Gallon Container		
Door Storage	•	•
1-Gallon Container Shelf Storage	•	•
Adjustable Wire Shelves in Fresh Food Compartment	•	•
Defrost Water Drain System	•	•
Interior Light in Fresh Food Compartment	•	•
3-Position Adjustable Freezer Shelf	•	•
Shelf and Juice Rack on Freezer Door	•	•
Crispers (quantity)	2	2
Door Bins in Fresh Food Compartment (quantity)	3	4

ORDER NUMBER

DM2662RB, DM2862RB	2-Way Black Frame
DM2662RBIMH, DM2862RBIMHF	2-Way Black Frame, Ice maker with heat option

RIGHT OR LEFT DOOR SWING OPTIONS

Right door swing (handle on left, hinges on right) is standard. Use product number to determine door reversing kit.

ORDER NUMBER

2932750116	Right to Left
------------	---------------

PRODUCT SPECIFICATIONS

DM2662RB SERIES

Overall Dimensions:	52 21/32" x 24 7/8" x 26 1/32"
Recess Dimensions:	53 3/4" x 23 11/16" x 24"
Weight:	124 lbs.

DM2862RB SERIES

Overall Dimensions:	60 51/64" x 24 7/8" x 26 1/32"
Recess Dimensions:	59 15/16" x 23 11/16" x 24"
Weight:	143 lbs.

NOTE: All models have 2 crispers, 6 cu. ft. models have 3 interior shelves, 8 cu. ft. models have 4 interior shelves

Subject to change without notice.

See page 67 for door insert panels

See page 68 for roof and side vents

See pages 69-71 for refrigerator replacement chart



AMERICANA DOUBLE DOOR REFRIGERATORS

- 2-way operation
- 6 or 8 cu. ft. capacity
- Flexible storage options
- Eye-level electronic controls with automatic electronic LP ignition system
- 3-position adjustable freezer shelf
- Two crispers
- Doors open 180°
- Easy clean white interior
- Removable door bins
- 2-liter bottle and 1/2-gallon container door storage
- Black frame
- Positive lock door handles

	DM2652	DM2852
AGA/CGA Certified	•	•
2-Way Operation (110V AC/LP Gas)	•	•
3-Way Operation (12V DC/110V AC/LP Gas)		

CONTROL PACKAGES

	DM2652	DM2852
Eye-Level Electronic Controls with Automatic Electronic LP Ignition System	•	•
Standby Operation Mode	•	•
Automatic Temperature Control	•	•

EXTERIOR FEATURES

	DM2652	DM2852
Modern Integrated Exterior Design Profile		
Ergonomically Designed Positive Lock	•	•
Door Handles	•	•
Climate Control Cooling System	•	•
Doors that Open 180°	•	•
CFC/HCFC-Free Foam Insulation	•	•

INTERIOR FEATURES

	DM2652	DM2852
Beautifully Sculpted, Practical and Easy-To-Clean White Interior	•	•
Adjustable, Removable Door Bins	•	•
2-Liter Bottle and 1/2-Gallon Container		
Door Storage	•	•
1-Gallon Container Shelf Storage	•	•
Adjustable Wire Shelves in Fresh Food Compartment	•	•
Defrost Water Drain System	•	•
Interior Light in Fresh Food Compartment	•	•
3-Position Adjustable Freezer Shelf	•	•
Shelf and Juice Rack on Freezer Door	•	•
Crispers (quantity)	2	2
Door Bins in Fresh Food Compartment (quantity)	3	4

ORDER NUMBER

DM2652RB	2-Way Black Frame
DM2852RB	2-Way Black Frame

RIGHT OR LEFT DOOR SWING OPTIONS

Right door swing (handle on left, hinges on right) is standard. Use product number to determine door reversing kit.

ORDER NUMBER

2932750116	Right to Left
------------	---------------

PRODUCT SPECIFICATIONS

DM2652

Overall Dimensions: 54 9/16" x 24 11/16" x 24 7/8"
Recess Dimensions: 53 3/4" x 23 11/16" x 24"
Weight: 122 lbs.

DM2852

Overall Dimensions: 60 5/8" x 24 11/16" x 24 7/8"
Recess Dimensions: 59 15/16" x 23 11/16" x 24"
Weight: 140 lbs.

Subject to change without notice.

See page 67 for door insert panels

See page 68 for roof and side vents

See pages 69-71 for refrigerator replacement chart



AMERICANA SINGLE DOOR REFRIGERATORS

- Black Frame
- 2-way or 3-way operation
- Top mounted controls

RM2351 & RM2354

- 3 cu. ft. capacity
- 1/2-gallon container shelf storage

RM2451 & RM2454

- 4 cu. ft. capacity
- Positive lock door handles
- Eye-level electronic controls with automatic electronic
- LP ignition system

RM2551 & RM2554

- 5 cu. ft. capacity
- Positive lock door handles
- Defrost water drain system
- 1-gallon container shelf storage

RM2351 RM2354 RM2451 RM2454 RM2551 RM2554

AGA/CGA Certified	•	•	•	•	•	•
2-Way Operation (110V AC/LP Gas)	•		•		•	
3-Way Operation (110V AC/LP Gas)				•		•

CONTROL PACKAGES

Eye-Level Electronic Controls with Automatic Electronic LP Ignition System	•	•	•	•	•	•
Standby Operation Mode	•	•	•	•		
Automatic Temperature Control	•	•	•	•	•	•

EXTERIOR FEATURES

Modern Integrated Exterior Design Profile						
Ergonomically Designed Positive Lock			•	•	•	•
Door Handles			•	•	•	•
Climate Control Cooling System						
Doors that Open 180°	•	•	•	•	•	•
CFC/HCFC-Free Foam Insulation	•	•	•	•	•	•

INTERIOR FEATURES

Beautifully Sculpted, Practical and Easy-To-Clean White Interior	•	•	•	•	•	•
Adjustable, Removable Door Bins			•	•	•	•
2-Liter Bottle and 1/2-Gallon Container						
Door Storage	•	•	•	•	•	•
1-Gallon Container Shelf Storage	1/2 gal	1/2 gal	•	•	•	•
Adjustable Wire Shelves in Fresh Food Compartment						
Defrost Water Drain System	•	•	•	•	•	•
Interior Light in Fresh Food Compartment						
3-Position Adjustable Freezer Shelf						
Shelf and Juice Rack on Freezer Door						
Crispers (quantity)					1	1
Door Bins in Fresh Food Compartment (quantity)	3	3	3	3	3	3

ORDER NUMBER

RM2351RB, RM2451RB, RM2551RB	2-Way
RM2354RB, RM2454RB, RM2554RB	3-Way

RIGHT OR LEFT DOOR SWING OPTIONS

Right door swing (handle on left, hinges on right) is standard. Use product number to determine door reversing kit.

ORDER NUMBER

385030401	RM2351RB Right to Left
293275013	RM2451RB, RM2551RB Right to Left

PRODUCT SPECIFICATIONS

RM2351RB, RM2354RB

Overall Dimensions:	30 3/8" x 21 11/16" x 22 1/16"
Recess Dimensions:	29 3/4" x 20 1/2" x 21 3/8"
Weight:	71 lbs.

RM2451RB, RM2454RB

Overall Dimensions:	37 3/8" x 24 11/16" x 24 7/8"
Recess Dimensions:	36 9/16" x 23 11/16" x 24"
Weight:	78 lbs.

RM2551RB, RM2554RB

Overall Dimensions:	43 1/2" x 24 11/16" x 24 7/8"
Recess Dimensions:	42 5/8" x 23 11/16" x 24"
Weight:	78 lbs.



REFRIGERATOR DOOR PANELS

WOOD GRAIN PANELS

ORDER NUMBER

3106863.008B	Main Panel RM2410.2R
3106863.016B	Main Panel RM2510.2R
3106863.024B	Both Panels RM2620R
3106863.057B	Main Panel RM2451/2454
3106863.065B	Main Panel RM2551/2554
3106863.073B	Both Panels DM2652
3106863.081B	Both Panels DM2852/2862
3106863.099B	Main Panel RM2193
3106863.156B	Both Panels RM3762
3106863.164B	Both Panels RM3962

BLACK ACRYLIC PANELS

ORDER NUMBER

3106863.008C	Main Panel RM2410.2R
3106863.016C	Main Panel RM2510.2R
3106863.024C	Both Panels RM2620R
3106863.057C	Main Panel RM2451/2454
3106863.065C	Main Panel RM2551/2554
3106863.073C	Both Panels DM2652
3106863.081C	Both Panels DM2852/2862
3106863.099C	Main Panel RM2193
3106863.156C	Both Panels RM3762
3106863.164C	Both Panels RM3962
3106863.198C	RML8555

FOR USE WITH RM1350

ORDER NUMBER

3106863.180B	Door Panel, Wood Grain, RM1350/RME1350
3106863.180C	Door Panel, Black, RM1350/RME1350

RAISED PANELS

ALUMINUM, BLACK AND BRONZE RAISED PANELS FOR RM3762

ORDER NUMBER

3314289.030A	Aluminum
3314289.030C	Black
3314289.030D	Bronze

RAISED PANELS FOR RM3962

ORDER NUMBER

3314289.020A	Aluminum
3314289.020C	Black
3314289.020D	Bronze

REFRIGERATOR ACCESSORIES

FOR USE WITH DOMETIC REFRIGERATOR MODELS:

RM2451/54	RM3662/63	RM2551/54
RM4872/72	RM2652	RM3732/7832
RM2852		

ORDER NUMBER

3106753.001	Magic Fingers™ - 2 per package
3107358.008	Adjustable Shelf Guards™ - One short and two long retainer bars and six clips per package
3106749.009	Meat Locker/Crisper - One tub and one lid per pkg.
3309867.004	Charcoal Filter - Stick-up charcoal deodorizer keeps refrigerators smelling sweet

REFRIGERATOR PACKAGED PARTS, VENTS, CAPS AND ASSEMBLIES

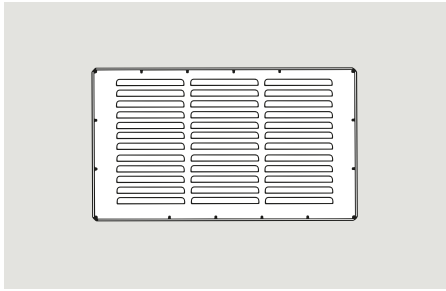

RM122

- 10 1/4" x 21"

ORDER NUMBER

8030122320 Upper Sidewall Vent, Polar White

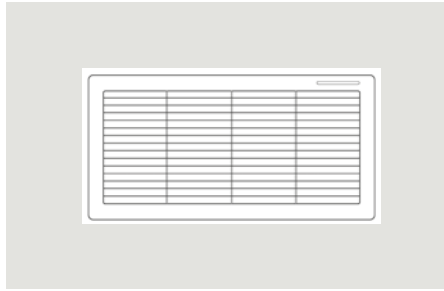

RM123

- 7 3/4" x 19 1/4"

ORDER NUMBER

3100451.024 Upper Sidewall, Vent, Polar White

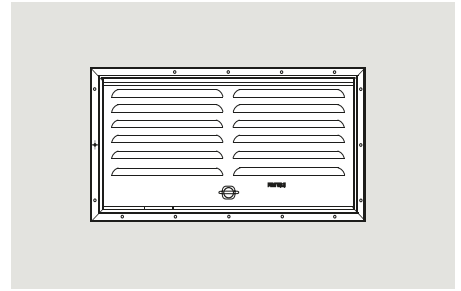

RM183 - LOWER SIDEWALL

- 9 11/16" x 19 1/4"

ORDER NUMBER

8030211322 Lower Sidewall, Vent, Polar White

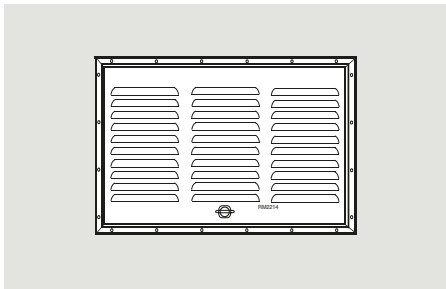

RM2214

- 14" x 22"

ORDER NUMBER

8032214320 Lower Sidewall Vent - Metal Square Corner Polar White

8032214330 Lower Sidewall Vent - Metal Square Corner Colonial White

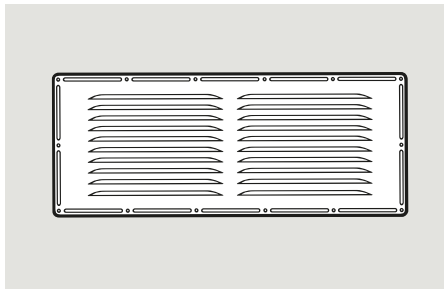

LS300

- 7" x 20"

ORDER NUMBER

958282466 Vent

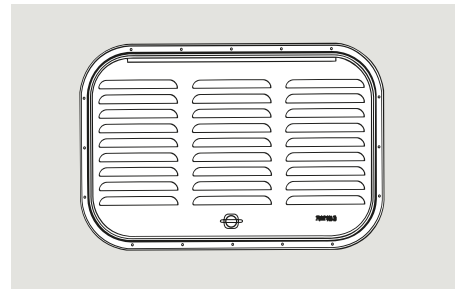

RM183 - SIDEWALL

- 14" x 22"

ORDER NUMBER

8032214R20 Sidewall Vent, Polar White

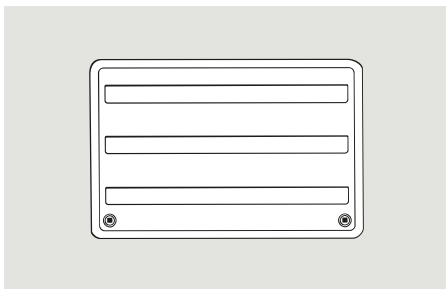

ORDER NUMBER

3109350.011 Lower Sidewall, Vent Plastic, Polar White

3109350.052 Lower Sidewall, Vent Plastic, Bright White

3109350.037 Lower Sidewall, Vent Plastic, Nu-Tru White

3109350.065 Lower Sidewall, Vent Plastic, Black

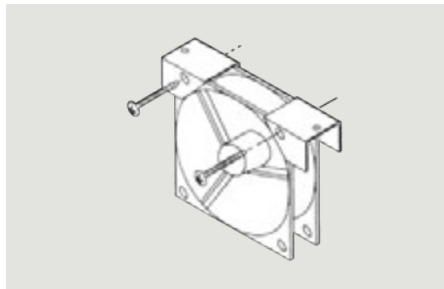

ORDER NUMBER

3108705.744 Ventilator kit, Double door with switch

3108705.751 Ventilator kit, Single door with switch

3313470.095 Limit Switch, Single door

3104133.016 Limit Switch, Double door

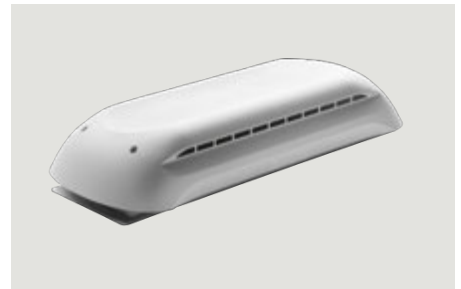

ORDER NUMBER

3311236.000 Roof Vent Kit, Polar White

3311236.024 Roof Vent Kit, Black

3312694.007 Base Only, Polar White

3312694.023 Base Only, Black

3312695.004 Cap Only, Polar White

3312695.020 Cap Only, Black

REFRIGERATOR PACKAGED PARTS, VENTS, CAPS AND ASSEMBLIES

REFRIGERATOR PACKAGED PARTS

ORDER NUMBER

200729000P	12V-10W Bulb
293113201P	Reignitor
3101833P006	Vent Latch
3108702.618	Freezer Spring and Housing - RH
3108702.626	Freezer Spring and Housing - LH
3850781018	Air Position Card
3851270011	Air Position Card - RM1350

UNIVERSAL CIRCUIT BOARDS

ORDER NUMBER

3308741.002	2-Way Universal
3316348.900	2-Way Universal with Built-in Reignitor
0151404001	Flue Brush
3308897.010	3 Amp Fuse
3308897.002	5 Amp Fuse
3315577.000	5 Amp Fuse - RM1350

DOMETIC REFRIGERATION OPTIONS

MODELS	TYPE				OPERATION		OPTIONAL IM	POWER SOURCE				RECESS DIMENSIONS		
	2+2	Lg. Dbl. Door	Sm. Dbl. Door	Single Door	2-Way 110/LP	3-Way 110/LP/12V		Absorption	Auto/Manual Auto LP	Electronic Auto/Elec LP	Manual Electronic LP	Piezo LP	Height	Width
ELITE 2+2														
RM1350	•				•		•	•				63 3/16	33 3/4	26 1/16
RM8551			•				•			•		32.48	20.74	23.50
RML8555			•				•	•				49.17	20.82	23.58
NEW GENERATION														
RM3762		•			•		•	•				53 3/4	23 11/16	24
RM3962		•			•		•	•				62 63/64	23 11/16	24
AMERICANA														
RM2351				•	•						•	29 3/4	20 1/2	21 3/8
RM2354				•			•				•	29 3/4	20 1/2	21 3/8
RM2451				•	•						•	36 9/16	23 11/16	24
RM2454				•			•				•	36 9/16	23 11/16	24
RM2551				•	•				•			42 5/8	23 11/16	24
RM2554				•			•	•				42 5/8	23 11/16	24
DM2652			•		•		•		•			53 3/4	23 11/16	24
DM2852		•			•		•		•			59 15/16	23 11/16	24
AMERICANA PLUS														
DM2662			•		•		•	•				53 3/4	23 11/16	24
DM2862		•			•		•	•				59 15/16	23 11/16	24
CLASSIC														
RM2620			•		•			•				49 1/2	21 3/4	24
COMPACT														
RM2193				•			•				•	21	17 3/4	21 1/2
RM4223				•			•				•	21	19 1/4	24

REPLACING AN OLD DOMETIC WITH A CURRENT MODEL (Measurements Shown In Inches)

MODELS	HEIGHT	WIDTH	DEPTH	DOMETIC REPLACEMENT OPTIONS	HEIGHT	WIDTH	DEPTH
RM24	22 3/8	19 3/8	19 7/8	RM2193	21	17 3/4	21 1/2
RM190	21 1/2	18 3/4	19 1/2	RM2193	21	17 3/4	21 1/2
RM211	22 11/16	19 5/8	17 5/8	RM2193	21	17 3/4	21 1/2
RM2150	17 1/2	17 3/4	21 1/2	RM2193	21	17 3/4	21 1/2
RM2190	21 1/2	17 3/4	20 1/2	RM2193	21	17 3/4	21 1/2
RM2191, 2193	21 7/8	17 3/4	20 7/8	RM2193	21	17 3/4	21 1/2
RM2200, 2201, 2202	22 1/4	19 1/2	18 1/4	RM2193	21	17 3/4	21 1/2
RM4290, 4292	29 5/8	20 5/8	20	RM2351, 2354	29 3/4	20 5/8	20
RM36	28 3/4	20 1/2	20 5/8	RM2351, RM2354	29 3/4	20 1/2	21 3/8
RM360, 361, 2300, 2301, 2310, 2332, 2333	29 3/4	20 1/2	21 3/8	RM2351, RM2354	29 3/4	20 1/2	21 3/8
RM45, 46, 47	31 1/4	21 7/8	23 5/8	RM2351, 2354	29 3/4	20 1/2	21 3/8
					32 7/16	21 13/16	24
RM460, 461, 2400, 2401, 2410	32 7/16	21 13/16	24	RM2410	32 7/16	21 13/16	24
RM760, 761, 763, 2600, 2601, 2610	51 3/8	21 13/16	24	RM2620	49 1/2	21 3/4	24
RM2602, 2603, 2604, 2607, 2611, 2612, 2620, RM 3600, 3601, 3604, 3607	49 9/16	21 7/8	24	RM2620	49 1/2	21 3/4	24
RM75, 76, 77	56 7/8	23 13/16	23 3/8	DM2852**, 2862**, RM3962*	59 15/16	23 11/16	24
RM100, 2802, 2803, 2804, 2807, 2811, 2812, RM 2820, 3800, 3801, 3804, 3807	55 7/16	23 11/16	24	DM2852**, 2862**	59 15/16	23 11/16	24
RM2800	57 1/2	23 13/16	23 3/4	DM2852**, 2862**, RM3962*	59 15/16	23 11/16	24
RM2801	57 15/16	24 15/16	24 11/16	DM2852**, 2862**, RM3962*	59 15/16	23 11/16	24
RM2810				DM2852**, 2862**, RM3962*	59 15/16	23 11/16	24
RM4801	62 13/16	23 13/16	24	DM2862**, RM3962*	59 15/16	23 11/16	24
RM4804	63	23 13/16	24	DM2862**, RM3962*	59 15/16	23 11/16	24
RM7030, 7130	57 1/8	32 3/4	24	RM1350	63 3/16	32 3/4	26 1/16
S520, 530, 1521, 1531, S519	43 1/4	23 1/2	24	RM2551, 2554	42 5/8	23 11/16	24
S620, 630, 1621, S1631, S619	52 5/8	23 1/2	24	DM2652**, 2662**, RM3762	53 3/4	23 11/16	24
S820, 830, 1821, 1831, S819	59 5/8	23 1/2	24	DM2852**, 2862**, RM3962*	59 15/16	23 11/16	24
RM2452, 2453	39 9/16	23 11/16	24	RM2451, 2454			
RM2552, 2553	42 5/8	23 11/16	24	RM2551, 2554	42 5/8	23 11/16	24
DM3662, 3663	53 3/4	23 11/16	24	DM2662**, RM3762	53 3/4	23 11/16	24
RM3862, 3863	59 15/16	23 11/16	24	DM2862**, RM3962*	59 15/16	23 11/16	24
RM4872, 4873	59 15/16	23 11/16	24	DM2852**, DM2862**, RM3962*	59 15/16	23 11/16	24
RM7732, 7832	59 1/16	32 11/16	24	RM1350	63 3/16	32 3/4	26 1/16
RM1272, 1282, NDRI272, 1282	59 1/16	36 1/2	24	RM1350	63 3/16	32 3/4	26 1/16
NDRI492	59 1/16	36 1/2	24	RM1350	63 11/64	32	26 1/16
NDA1402	63 3/16	32 3/4	26 1/16	RM1350 (add 5")	63 3/16	32 3/4	26 1/16
NDM1062	59 15/16	23 11/16	24	DM2862	59 15/16	23 11/16	24
				RM3962	62 61/64	23 11/16	24
NDRI292	59 1/16	32 11/16	24	RM1350	63 3/16	32 3/4	26 1/16
RM2820	55 3/8	23 5/8	24	DM2662, RM3762 (with 3313470.072 Retro fit kit)	53 3/4	23 11/16	24

* RM3962 approximately 3" higher than DM models.

**DM2652 = RM2652, DM2662 = RM2662, DM2663 = RM2663, DM2852 = RM2852, DM2862 = RM2862, DM3662 = RM3662, DM3663 = DISCONTINUED, DM3862 = RM3862, DM3863 = DISCONTINUED, NDRI062 = NDM1062

REPLACING AN OTHER REFRIGERATORS WITH A DOMETIC MODEL (Measurements Shown In Inches)

MODELS	HEIGHT	WIDTH	DEPTH	DOMETIC REPLACEMENT OPTIONS	HEIGHT	WIDTH	DEPTH
REPLACING A NORCOLD WITH A DOMETIC							
322, 333	20 5/8	17 1/2	21 1/4	RM2193	21	17 3/4	21 1/2
442, 443	30 7/8	23 1/2	24	RM2351, 2354	29 3/4	20 1/2	21 3/8
					32 7/16	21 13/16	24
452, 453	42 1/4	23 5/8	24	RM2551, 2554	42 5/8	23 11/16	24
652, 653	42 1/4	23 5/8	24	RM2551, 2554	42 5/8	23 11/16	24
N510, 512	43 1/4	23 1/2	24	RM2551, 2554	42 5/8	23 11/16	24
838	51 7/8	23 15/16	23 1/4	DM2652**, 2662**, RM3762	53 3/4	23 11/16	24
462, 463, 662, 663, 641	52 7/8	23 1/2	24	DM2652**, 2662**, RM3762	53 3/4	23 11/16	24
876	52 1/8	24	24	DM2652**, 2662**, RM3762	53 3/4	23 11/16	24
8662	52 1/2	23 5/8	24	DM2652**, 2662**, RM3762	53 3/4	23 11/16	24
8310	58 7/8	23 15/16	23 1/2	DM2852**, 2862**, RM3962	59 15/16	23 11/16	24
878	59	24	24	DM2852**, 2862**, RM3962	59 15/16	23 11/16	24
482, 483, 682, 683, 841	59 7/8	23 1/2	24	DM2852**, 2862**, RM3962	59 15/16	23 11/16	24
8010	59	23 7/8	24	DM2852**, 2862**, RM3962	59 15/16	23 11/16	24
8682	59 1/2	23 5/8	24	DM2852**, 2862**, RM3962	59 15/16	23 11/16	24
N260/N260.3	21	19 3/8	24	RM2193	21	17 3/4	21 1/2
N300/N300.3	29 3/4	20 1/2	21 3/8	RM2351	29 3/4	20 1/2	21 3/8
				RM2354	42 5/8	23 11/16	24
N510/N510.3	42 5/8	23 11/16	24	RM2551	42 5/8	23 11/16	24
				RM2554	42 5/8	23 11/16	24
N641/N641.3	52 7/8	29 1/2	24	RM2620	49 1/2	21 3/4	24
				DM2652, RM3762	53 3/4	23 11/16	24
N841/N841.3	59 7/8	29 1/2	24	DM2852**, RM3962	55 3/8	23 5/8	24
				DM2862**	59 15/16	23 11/16	24
N1210	63 1/4	32 11/16	24	RM1350	63 3/16	32 3/4	26 1/16
REPLACING AN INSTAMATIC WITH A DOMETIC							
RV-2-201	21 3/4	19 3/16	18 3/16	RM2193	21	17 3/4	21 1/2
IM-2	22 1/4	18 1/8	16 5/8	RM2193	21	17 3/4	21 1/2
RV-3-301	28 3/4	20 11/16	19 7/16	RM2351, 2354	29 3/4	20 1/2	21 3/8
IM-3	28 3/4	20 1/4	18 5/8	RM2351, 2354	29 3/4	20 1/2	21 3/8
RV-4-401	33 15/16	20 11/16	21 5/8	RM2410	32 7/16	21 13/16	24
IM-4 31	21 5/8	22 5/8	RM2410	32 7/16	21 13/16	24	
RV-7-701	53 1/8	23 7/8	23 1/4	DM2652**, 2662**, RM3762	53 3/4	23 11/16	24
IM-270	51 3/4	23 3/4	23 1/4	DM2652**, 2662**, RM3762	53 3/4	23 11/16	24
IM-70	52	24	23	DM2652**, 2662**, RM3762	53 3/4	23 11/16	24
RV-8-801	59 5/16	23 7/8	23 3/4	DM2852**, 2862**, 3962	59 15/16	23 11/16	24
REPLACING A SIBIR WITH A DOMETIC							
RV-104	30 5/16	23 1/2	23	RM2351, 2354	29 3/4	20 1/2	21 3/8
RV-106	34 3/8	23 1/2	23		32 7/16	21 3/16	24
				RM2451, 2454	36 9/16	23 11/16	24
RV-240	34 1/8	23 1/2	23		32 7/16	21 13/16	24
				RM2451, 2454	36 9/16	23 11/16	24
RV-108	54 3/8	23 1/2	23	DM2652**, 2662**, RM3762	53 3/4	23 11/16	24
RV-270	54 1/16	23 1/2	23	DM2652**, 2662**, RM3762	53 3/4	23 11/16	24
RV-110	64 3/8	23 1/2	23	DM2852**, 2862**, RM3962	59 15/16	23 11/16	24
RV-280	59	23 1/2	23	DM2852**, 2862**, RM3962	59 15/16	23 11/16	24



CLIMATE

FOOD & BEVERAGE

HYGIENE & SANITATION

SAFETY & SECURITY



ICE COLD, BUT NO ICY MESS

MOBILE COOLING



CFX 28

- Soft-touch digital controls
- Set temperature from -7°F to +50°F (-22°C to +10°C)
- Quick-chill/turbo function
- Strong latches, hinges & drop-down handles
- Memory maintains preset temperatures even if system is turned off
- Runs on 120VAC, 12VDC or 24VDC power source
- Holds up to 43 drink cans

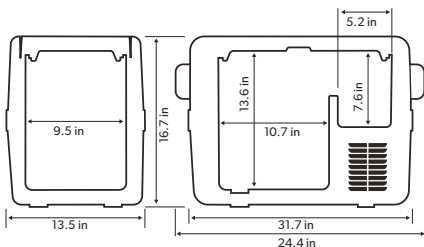

ORDER NUMBER

CFX-28

PRODUCT SPECIFICATIONS

Weight: 29 lbs | 13.1 kg
 Dimensions: 16.7" H x 24.4" W x 13.4" D |
 425 x 552 x 342 mm
 Storage: 26 liters | .9 cu. ft. |
 27 quarts



CFX 35

- Soft-touch digital controls
- Set temperature from -7°F to +50°F (-22°C to +10°C)
- Quick-chill/turbo function
- Strong latches, hinges & drop-down handles
- Memory maintains preset temperatures even if system is turned off
- Runs on 120VAC, 12VDC or 24VDC power source
- WiFi enabled app allows temperature control over a smart device
- Holds up to 47 drink cans

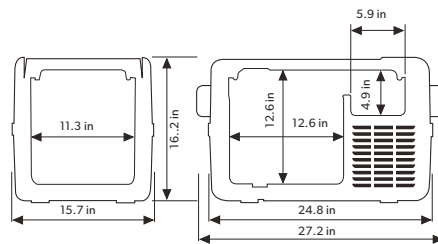

ORDER NUMBER

CFX-35W

PRODUCT SPECIFICATIONS

Weight: 39 lbs | 17.5 kg
 Dimensions: 16.2" H x 27.2" W x 15.7" D |
 411 x 662 x 398 mm
 Storage: 32 liters | 1.1 cu. ft. |
 34 quarts



CFX 40

- Soft-touch digital controls
- Set temperature from -7°F to +50°F (-22°C to +10°C)
- Quick-chill/turbo function
- Strong latches, hinges & drop-down handles
- Memory maintains preset temperatures even if system is turned off
- Runs on 120VAC, 12VDC or 24VDC power source
- WiFi enabled app allows temperature control over a smart device
- Holds up to 60 drink cans

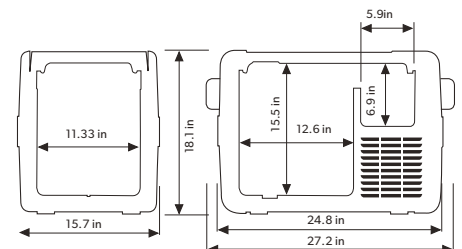

ORDER NUMBER

CFX-40W

PRODUCT SPECIFICATIONS

Weight: 41 lbs | 18.5 kg
 Dimensions: 18.1" H x 27.2" W x 15.7" D |
 461 x 692 x 398 mm
 Storage: 38 liters | 1.4 cu. ft. |
 40 quarts



CFX 50

- Soft-touch digital controls
- Set temperature from -7°F to +50°F (-22°C to +10°C)
- Quick-chill/turbo function
- Strong latches, hinges & drop-down handles
- Memory maintains preset temperatures even if system is turned off
- Runs on 120VAC, 12VDC or 24VDC power source
- WiFi enabled app allows temperature control over a smart device
- Holds up to 72 drink cans

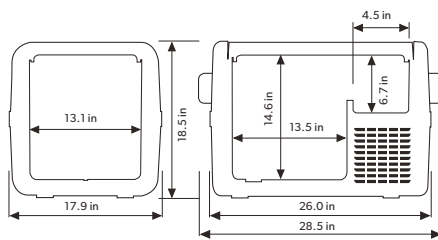

ORDER NUMBER

CFX-50W

PRODUCT SPECIFICATIONS

Weight: 45 lbs
 Dimensions: 18.5" H x 28.5 W x 17.9"D | 471 x 725 x 455 mm
 Storage: 46 liters | 1.8 cu. ft. | 48.6 quarts



CFX 65W

- Soft-touch digital controls
- Set temperature from -7°F to +50°F (-22°C to +10°C)
- Quick-chill/turbo function
- Strong latches, hinges & drop-down handles
- Memory maintains preset temperatures even if system is turned off
- Runs on 120VAC, 12VDC or 24VDC power source
- WiFi enabled app allows temperature control over a smart device
- Holds up to 106 drink cans

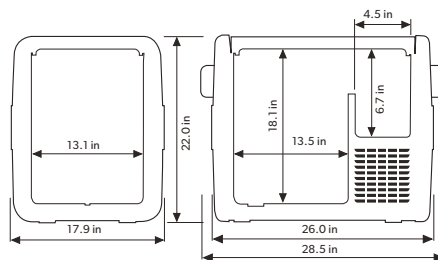

ORDER NUMBER

CFX-65W

PRODUCT SPECIFICATIONS

Weight: 51 lbs | 23.2 kg
 Dimensions: 22" H x 28.5" W x 17.9" D | 561 x 725 x 455 mm
 Storage: 61 liters | 2.2 cu. ft. | 64 quarts



CFX 65DZ

- Dual zone cooling and freezing
- Soft-touch digital controls
- Set temperature from -7°F to +50°F (-22°C to +10°C)
- Quick-chill/turbo function
- Strong latches, hinges & drop-down handles
- Memory maintains preset temperatures even if system is turned off
- Runs on 120VAC, 12VDC or 24VDC power source
- Holds up to 60 drink cans (fridge only)

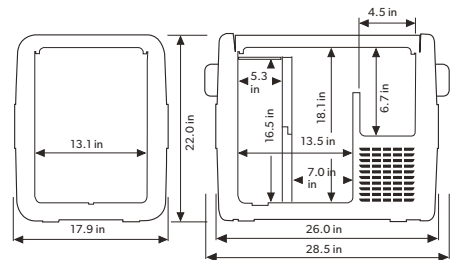

ORDER NUMBER

CFX-65DZ

PRODUCT SPECIFICATIONS

Weight: 51 lbs | 23.2 kg
 Dimensions: 22" H x 28.5" W x 17.9" D | 561 x 725 x 455 mm
 Storage: 53 liters | 2.2 cu. ft. | 56 quarts



CFX 95DZ

- 2 independently controlled compartments for cooling and freezing
- Set temperature from -7°F to +50°F (-22°C to +10°C)
- Quick-chill/turbo function
- Strong latches, hinges & drop-down handles
- Memory maintains preset temperatures even if system is turned off
- Runs on 120VAC, 12VDC or 24VDC power source
- WiFi enabled app allows temperature control over a smart device
- Holds up to 133 drink cans

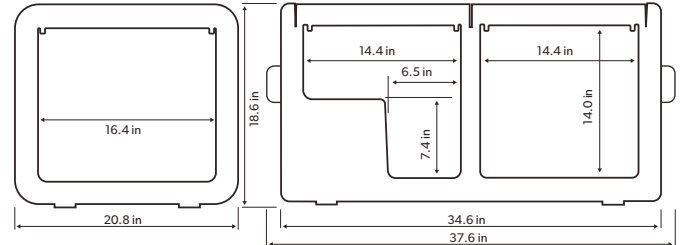

ORDER NUMBER

CFX-95DZW

PRODUCT SPECIFICATIONS

Weight: 70.5 lbs | 32 kg
 Dimensions: 18.6" H x 37.6" W x 20.8" D | 557 x 985 x 500 mm
 Storage: 90 quarts, 53.5 + 36.5 quarts | 85 Liter, 50,5 + 34



CFX 100

- Quick-chill/turbo function
- Strong latches, hinges & drop-down handles
- Memory maintains preset temperatures even if system is turned off
- Runs on 120VAC, 12VDC or 24VDC power source
- WiFi enabled app allows temperature control over a smart device
- Holds up to 146 drink cans

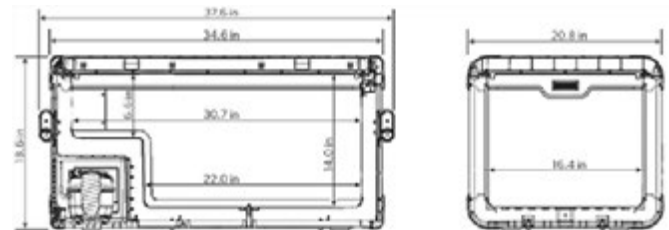

ORDER NUMBER

CFX-100W

PRODUCT SPECIFICATIONS

Weight: 70.5 lbs | 32 kg
 Dimensions: 18.6" H x 37.6" W x 20.8" D | 557 x 985 x 500 mm
 Storage: 94.5 liters | 3.3 cu. ft. | 86 quarts



CFX WIRELESS DISPLAY

- Compatible with all CFX portable coolers
- Wireless (2.4GHz) range up to 49 ft | 15 m
- Displays: fridge temperature and fridge power source battery protection setting
- Temperature alarm setting 2 levels: audible & visual alarm
- Backlit display

ORDER NUMBER

CFX-WD

PRODUCT SPECIFICATIONS

Weight: 0.22 lbs | .09 kg
Power: 2 AAA Batteries or 12/24 V



CFX FRIDGE SLIDES

- 220 lbs max load capacity
- Two sets of mounting holes
- Includes: 4 x heavy duty straps, 4 x quick release buckles
- 1 year warranty

ORDER NUMBER | PRODUCT SPECIFICATIONS

CFX-SLD3540 Weight: 36.4 lbs | 16.5 kg
CFX-SLD5065 Weight: 37.5 lbs | 17 kg



CFX INSULATED PROTECTIVE COVERS

- Protects against outside heat
- Eyelets for securing firmly in a vehicle
- Top flap swings open with lid
- Open panels for handles and connection plugs
- Sides and top made from high quality silver-gray Oxford nylon fabric

ORDER NUMBER

CFX-IC28 Insulated Protective Cover
CFX-IC35 Insulated Protective Cover
CFX-IC40 Insulated Protective Cover
CFX-IC50 Insulated Protective Cover
CFX-IC65 Insulated Protective Cover
CFX-IC95 Insulated Protective Cover

AVALANCHE HEAVILY INSULATED COOLERS

The ultimate outdoor coolers

- Keep ice cold for 7-10 days
- Freezer-style seal
- Roto-molded design
- Heavy-duty latches
- Dry-ice compatible
- Non-toxic and UV-resistant materials
- Molded cup holders to secure drinks
- Limited 7-year warranty
- 2-inch drain plug on stainless steel chain stays put



AVAL35L

- 30 qt. capacity

ORDER NUMBER | PRODUCT SPECIFICATIONS

AVAL35L
Dimensions: 24.7" L x 14.4" H x 15.2" W
Weight: 21.3 lbs.



AVAL55L

- 49.7 qt. capacity

ORDER NUMBER | PRODUCT SPECIFICATIONS

AVAL55L
Dimensions: 27.3" L x 16.1" H x 18.3" W
Weight: 27.3 lbs.



AVAL65LW

- 62.1 qt. capacity
- Wheels and telescoping handle

ORDER NUMBER | PRODUCT SPECIFICATIONS

AVAL65LW
Dimensions: 23.4" L x 22.5" H x 17.6" W
Weight: 8.7 lbs.



CC-32

- Battery Protection System
 - Select at high, medium and low level
 - Cuts off fridge when battery voltage drops to pre-set value
- Uses light-weight compressor
- Sturdy handle with hook that can be used as an anchor point to keep the box in position
- Set temperature between 3.2° F to 50° F (10° C to -16° C)



CC-40

- Battery Protection System
 - Select at high, medium and low level
 - Cuts off fridge when battery voltage drops to pre-set value
- Uses light-weight compressor
- Sturdy handle with hook that can be used as an anchor point to keep the box in position
- Set temperature between 3.2° F to 50° F (10° C to -16° C)



CDF-11

- Holds 6 cans
- Operates as a refrigerator or freezer
- Lightweight and portable
- Battery monitor with low-voltage shut-off protects against a dead battery
- Memory feature maintains presets if the system is turned off

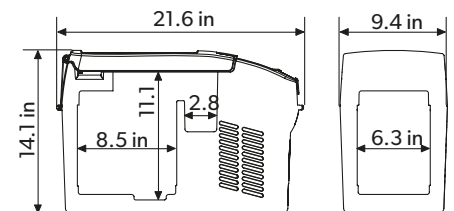

ORDER NUMBER

CC-32

PRODUCT SPECIFICATIONS

Weight: 25.2 lbs | 11.4kg
 Dimensions: 14.3" H x 23.0" W X 16.0" L |
 365 x 584 x 407 mm
 Storage: 31 liters | 1.1 cu ft |
 33.8 quarts

ORDER NUMBER

CC-40

PRODUCT SPECIFICATIONS

Weight: 24.5 lbs | 11.1 kg
 Dimensions: 14.3" H x 23" W x 17.6" L |
 363 x 584 x 447 mm
 Storage: 38 liters | 1.3 cu. ft. |
 40 quarts

ORDER NUMBER

CDF-11

PRODUCT SPECIFICATIONS

Weight: 19 lbs | 8.8 kg
 Dimensions: 14.1" H x 21.6" W x 9.4" D |
 358 x 450 x 235 mm
 Storage: 11 liters | .4 cu. ft. | 10 quarts



CF-018

- Holds 23 cans
- Operates as a refrigerator or freezer
- Quick-chill functions runs compressor at high capacity until desired temperature is reached
- Lightweight and portable
- Battery monitor with low-voltage shut-off protects against a dead battery
- Memory feature maintains presets if the system is turned off

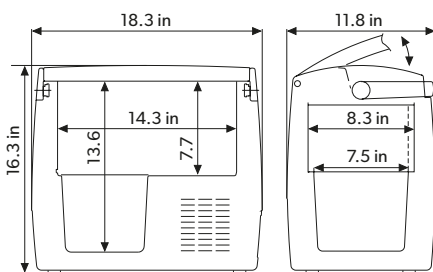

ORDER NUMBER

CF-018-D65-B

PRODUCT SPECIFICATIONS

Weight: 25 lbs | 11.5 kg
 Dimensions: 16.3" H x 18.3" W x 11.8" D | 465 x 414 x 300 mm
 Storage: 18 liters | .7 cu. ft. | 19 quarts



CF-025

- Holds 27 cans
- Operates as a refrigerator or freezer
- Quick-chill functions runs compressor at high capacity until desired temperature is reached
- Lightweight and portable
- Battery monitor with low-voltage shut-off protects against a dead battery
- Memory feature maintains presets if the system is turned off

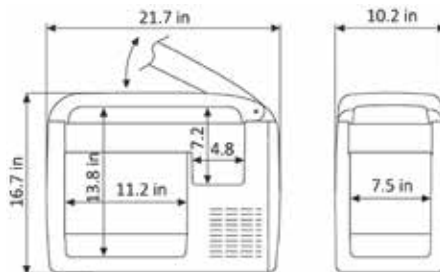

ORDER NUMBER

CF-025DC-D65-B

PRODUCT SPECIFICATIONS

Weight: 28 lbs | 12.5 kg
 Dimensions: 16.7 H x 21.7" W x 10.2" D | 425 x 550 x 260 mm
 Storage: 23 liters | .9 cu. ft. | 24 quarts



CF-80

- Holds 103 cans
- Operates as a refrigerator or freezer
- Quick-chill functions runs compressor at high capacity until desired temperature is reached
- Battery monitor with low-voltage shut-off protects against a dead battery
- Memory feature maintains presets if the system is turned off

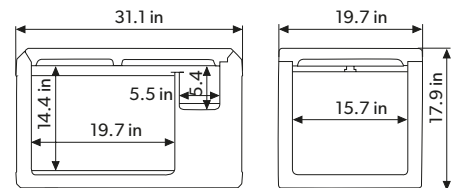

ORDER NUMBER

CF-080AC110

PRODUCT SPECIFICATIONS

Weight: 68 lbs | 31 kg
 Dimensions: 17.9" H x 31.1" W x 19.7" D | 455 x 790 x 500 mm
 Storage: 80 liters | 2.8 cu. ft. | 85 quarts

TROPICOL THERMOELECTRIC PORTABLE COOLERS/WARMERS

Cooling down to 32° below ambient temperature and up to 65° in warmer mode

- Capacity up to 1.17 cu. ft.
- Plug into 12V DC or 120V AC
- Digital controls
- LED temperature display
- Detachable lid with magnetic closure
- Sturdy, fold-away handles
- Wear-free thermoelectric system and fan
- 7-stage temperature regulation for heating and cooling
- 1-year warranty
- AC and DC power cords included



TC-14US

- 0.49 cu. ft. capacity
- 3.8 / 0.4 Amps

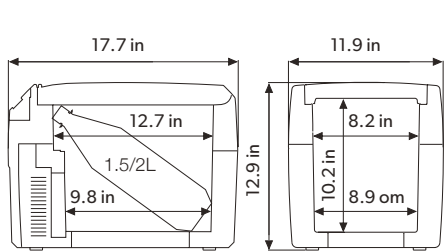

ORDER NUMBER

TC-14US

PRODUCT SPECIFICATIONS

Dimensions: 12.9" H x 17.7" W x 11.9" D |
328 x 450 x 303 mm

Weight: 13.7 lbs.



TC-21US

- 0.71 cu. ft. capacity
- 3.8 / 0.4 Amps

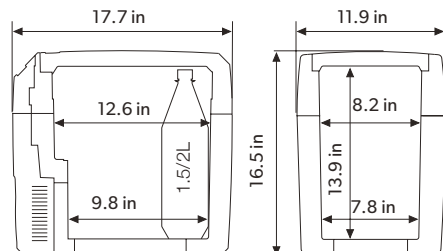

ORDER NUMBER

TC-21US

PRODUCT SPECIFICATIONS

Dimensions: 16.5" H x 17.7" W x 11.9" D |
420 x 450 x 303 mm

Weight: 16.3 lbs.



TC-35US

- 1.17 cu. ft. capacity
- 3.8 / 0.4 Amps

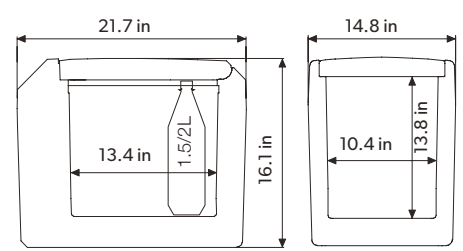

ORDER NUMBER

TC-35US

PRODUCT SPECIFICATIONS

Dimensions: 16.1" H x 21.7" W x 14.8" D |
460 x 550 x 376 mm

Weight: 22.5 lbs.



A CAMPFIRE IS OPTIONAL
COOKING



MICROWAVE OVENS

- 1.1 cubic foot capacity to help conserve counter space while allowing plenty of room to cook
- 1000 watts cooking power
- 10 adjustable power levels to let you boil, reheat, defrost, and more
- Speed and weight defrost
- 9 pre-programmed, 1 touch digital cook settings allow easy preparation of potato, popcorn, pizza, frozen entrées, beverages & reheat
- Digital timer and digital clock with LED display
- Removable glass turntable rotates food to provide even cooking
- Child safety lock to prevent unsupervised usage
- Stainless steel cavity, black oven & trim kit, with stainless steel trim adds style to your RV kitchen
- Trim kit and exhaust kit included
- Grill & Convection functions offered in model DCMC11B.F

ORDER NUMBER

DCMW11B.F	Black
DCMC11B.F	Black Convection

*IEC 60705 rating standard output

TRIM KIT

DCMW11B.FO	Black, fits both models
------------	-------------------------

REPLACEMENT PARTS

203059000038	Rotating Ring
243019000008	Glass Tray

PRODUCT SPECIFICATIONS

DCMW11B SERIES

Outside Dimensions: 12 7/8" x 21 1/4" x 15 11/16"
 Built-in Dimensions: 20 3/4" x 25 1/4" x 19 9/16"
 Weight: 35 lbs.



OVER-THE-RANGE MICROWAVE OVENS

- 1.6 cubic foot capacity
- 1000 watts cooking power to help meet a range of cooking needs from making hearty dishes to heating beverages and delicate sauces
- 1-touch electronic controls for simple, reliable operation; electronic clock and timer display assist in coordinating meals
- Spacious XL 1.8 cu. ft. interior with an adjustable metal rack to accommodate a variety of dishes
- Turntable provides a sturdy, rotating surface for even cooking; ON/OFF setting allows control of rotation
- 9-sensor cook options automatically monitor food progress and adjust times & temps as needed for delicious results
- Work/night lights illuminate prep surfaces

ORDER NUMBER

DOTR16B	Black
---------	-------

PRODUCT SPECIFICATIONS

DOTR16B SERIES

Overall Dimensions: 16 7/8" x 29 7/8" x 17 5/8"
 Weight: 60 lbs.



ATWOOD 3-BURNER RANGES

- Standard piezo ignition and stamped grates
- Sealed burners keep spills from accumulating under the range top
- High output 9,000 BTU front and 6,500 BTU rear burners
- Built in broiler and toaster
- 17" cut-out: 17¾"D x 16"H x 20¼"W
- 21" cut-out: 17¾"D x 20"H x 20¼"W
- RA Series
- Optional bifold cover available
- 2 year warranty

ORDER NUMBER

52769	17" Range w/Piezo Igniter, Black
52786	21" Range w/Piezo Igniter, Black
52776	17" Range w/Piezo, Stainless
52815	21" Range, w/Piezo, Stainless



WEDGEWOOD 3-BURNER RANGES

- Burners easily adjust from low simmer to full burn
- High output 9,000 BTU front and 6,500 BTU rear burners
- Seamless surface for cleaner cooking areas and caulless installation
- Top burner areas have a deep well that contains messy spills
- Built in broiler and toaster
- 17" cut-out: 17¾"D x 16"H x 20¼"W
- 21" cut-out: 17¾"D x 20"H x 20¼"W
- RV Series
- Optional bifold cover available
- 2 year warranty

ORDER NUMBER

52373	17" Range w/Piezo Igniter, Black
52232	21" Range w/Piezo Igniter, Black
52458	17" Range, Black Door
52275	21" Range, Black Door

DROP-IN COOKTOP COVERS

Covers available in black and stainless steel. Fits Wedgewood Vision® drop-in cooktops.

ORDER NUMBER

56458	2-Burner, Black
56459	2-Burner, Stainless Steel
56460	3-Burner, Black
56461	3-Burner, Stainless Steel



BI-FOLD COVER

Fits 17" and 21" RV, RA, CV, & CA Series. 2 Year Warranty.

ORDER NUMBER

54106	Black Metal
54102	Stainless Steel
50178	Glass Bi-fold
50181	Glass Bi-fold with Trim Kit



WEDGEWOOD VISION® SLIDE-INS

- Boil water 75% faster than standard cooktop burners
- 1,100 to 9,000 BTU linear valves
- Two enhanced 6,500 BTU rear burners
- CV Series
- 2 Year warranty.

ORDER NUMBER

52943	Black, Match Lit
52945	Stainless Steel, Match Lit
52939	Black, Piezo Igniter
52942	Stainless Steel, Piezo Igniter



ATWOOD SLIDE-INS

- Same great features as the Wedgewood Vision® slide-in with a few upgrades.
- Features standard piezo ignition, stamped grates, and sealed burners
- CA Series
- 2 Year warranty

ORDER NUMBER

52961	Black, Piezo Igniter
52973	Stainless Steel, Piezo Igniter



WEDGEWOOD VISION® COOKTOPS

- 2-burner cooktop has a 7,200 BTU and 5,200 BTU burner
- 3-burner cooktop has one 7,200 BTU and two 5,200 BTU burners
- Control panel and burner knobs are easy to use
- One piece surface for cleaner cooking area
- Covers with wind guards protect your cooktop and increase countertop space when cooktop is not in use
- Cooktops and covers available in black and true stainless steel

2-BURNER COOKTOPS

ORDER NUMBER

56493	2-Burner, Black
56494	2-Burner, Stainless Steel

3-BURNER COOKTOPS

ORDER NUMBER

56471	3-Burner, Black
56472	3-Burner, Stainless Steel

REPAIR PARTS

ORDER NUMBER

53009	Grommet, Rubber (Vision)
56148	Knob Burner, Mini Valve, Black
56096	Piezo 3-Burner Rotary
51062	Gas Regulator Kit

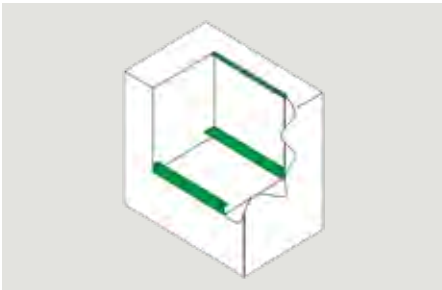

CONVERSION KIT RANGE

- Allows you to replace a Magic Chef/Amana range with an Atwood or Wedgewood range
- Replace a Magic Chef/Amana 22" range with a cabinet cutout of 20 5/8" wide x 19 7/16" deep x 21 13/16" tall with an Atwood or Wedgewood 21" range
- Replace of a Magic Chef/Amana 16" range with a cabinet cutout of 20 5/8" wide x 19 7/16" deep x 16 3/8" tall with an Atwood or Wedgewood 17" range

ORDER NUMBER

52907	Large Range Conversion Kit, Black
52906	Small Range Conversion Kit, Black



STOVE WRAP

- Designed to reduce or even eliminate the clean up after cooking
- No more wiping and scrubbing your stove top to get it clean
- Keeps your stove top looking new and hide scuffed and scratched areas

ORDER NUMBER

52933	Stove Wrap, Stovetop Liner for Atwood
52934	Stove Wrap, Stovetop Liner for Suburban

/ SANITATION
/ CLEANING
/ WATER HEATERS

HYGIENE SANITATION



ENE & ATION



RELIABILITY MEANS EVERYTHING
SANITATION



MASTERFLUSH® MODEL 8740

- Powerful macerating flush
- Residential toilet height and elongated seat for premium comfort
- Low (0.21 gpf/0.79 lpf) and Normal (0.83 gpf/3.14 lpf) flush options
- Quieter, shorter flush duration than many other macerator toilets
- Electronic flush handle in chrome finish

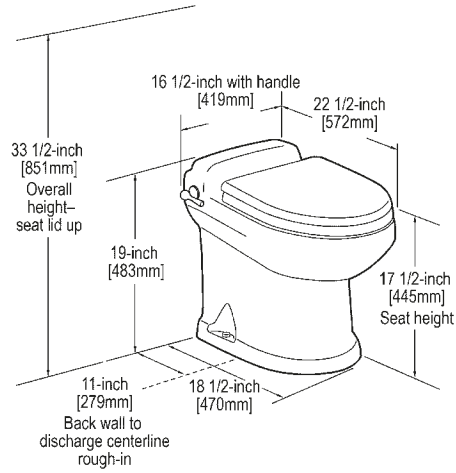

ORDER NUMBER

304874002	Flush Handle, 12V, White
304874003	Flush Handle, 12V, Bone
304874009	Flush Handle, 24V, White
304874010	Flush Handle, 24V, Bone



MASTERFLUSH® MODEL 8743

- Powerful macerating flush
- Residential toilet height and elongated seat for premium comfort
- Low (0.21 gpf/0.79 lpf) and Normal (0.83 gpf/3.14 lpf) flush options
- Quieter, shorter flush duration than many other macerator toilets
- Wall-mounted electronic flush touchpad

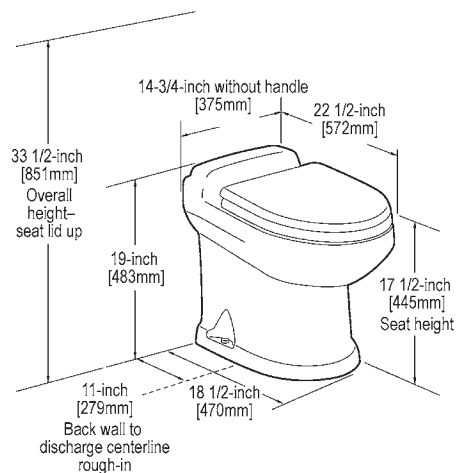

ORDER NUMBER

304874301	Wall Switch, 12V, White
304874303	Wall Switch, 12V, Bone
304874302	Wall Switch, 24V, White
304874304	Wall Switch, 24V, Bone



MODEL 4310

- Robust, bowl-clearing gravity flush
- Residential toilet height and elongated seat for premium comfort
- Low water use: 0.13 gal/0.49 l per flush
- Electronic flush handle in chrome finish
- Optional hand sprayer

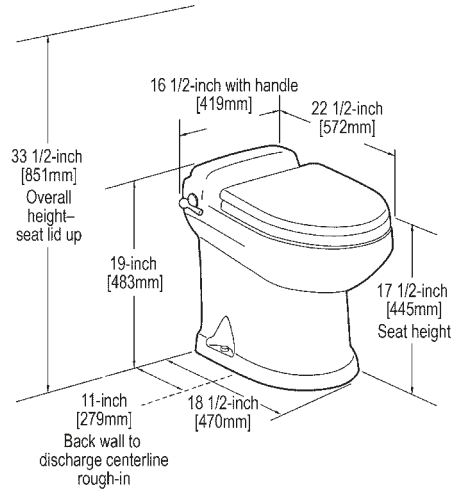

ORDER NUMBER

302431111	Chrome Flush Lever, White
302431131	Chrome Flush Lever, Bone
302431211	Chrome Flush Lever, White with Hand Spray
302431231	Chrome Flush Lever, Bone with Hand Spray



MODEL 4410

- Robust, bowl-clearing gravity flush
- Residential toilet height and elongated seat for premium comfort
- Low water use: 0.13 gal/0.49 l per flush
- Wall-mounted electronic flush switch
- Optional hand sprayer

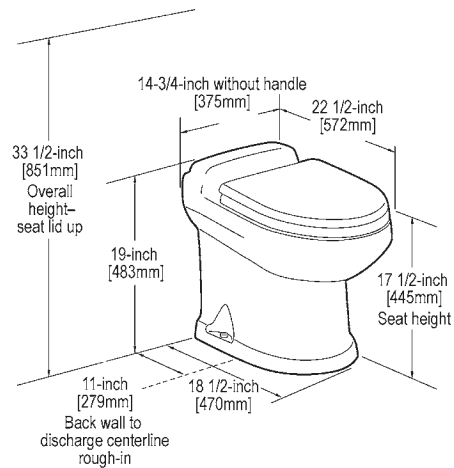

ORDER NUMBER

302441110	Wall Switch, White
302441130	Wall switch, Bone
302441210	Wall Switch, White with Hand Spray
302441230	Wall Switch, Bone with Hand Spray

320 SERIES

- Robust, bowl-clearing gravity flush; integrated rim prevents spills
- Elongated seat and ceramic bowl for premium comfort and hygiene
- Uses as little as one pint (0.13 gal/0.5 l per flush)
- Ergonomic knee- and hip-friendly seat height (standard height models)
- Optional hand sprayer

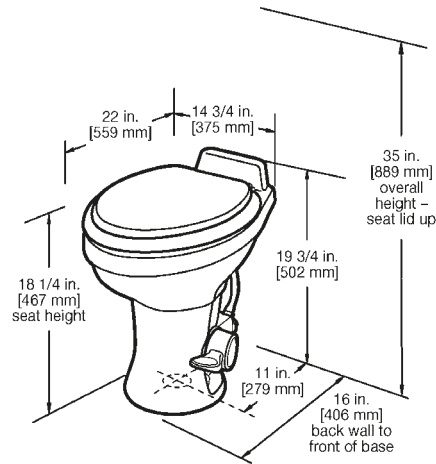

ORDER NUMBER

STANDARD HEIGHT - 18" H

302320081	White
302320083	Bone
302320181	White, With Hand Spray
302320183	Bone, With Hand Spray

LOW PROFILE - 14" H

302321681	White
302321683	Bone
302321781	White, With Hand Spray
302321783	Bone, With Hand Spray

ACCESSORIES

385311719	Mounting Adapter Kit - White
385311720	Mounting Adapter Kit - Bone
385311718	Water Line Extension Kit
385319054	Hand Spray Kit - White

310 SERIES

- NEW! Slow-close enameled wood seat improves user control and comfort
- Robust, bowl-clearing gravity flush; 360° vortex flush pattern
- Uses as little as one pint (0.13 gal/0.5 l per flush)
- Ceramic bowl for easier rinsing
- Ergonomic knee- and hip-friendly seat height (standard height models)
- Optional hand sprayer

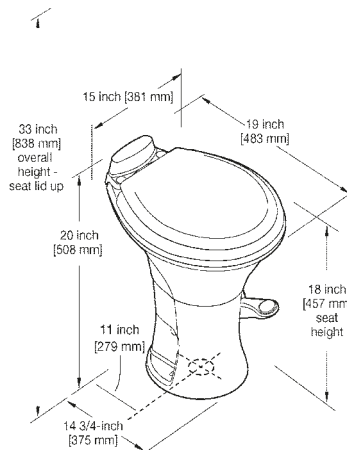

ORDER NUMBER

STANDARD HEIGHT - 18" H

302310081	White
302310083	Bone
302310181	White, with hand spray
302310183	Bone, with hand spray

LOW PROFILE- 13 3/4" H

302311681	White
302311683	Bone
302311781	White, with hand spray
302311783	Bone, with hand spray

ACCESSORIES

385311719	Mounting Adapter Kit - White
385311720	Mounting Adapter Kit - Bone
385311718	Water Line Extension Kit
385311658	310 Seal
385311641	Water Valve Kit
385312073	Slow Close Wooden Seat - White*
385312074	Slow Close Wooden Seat - Bone*
385319054	Hand Spray Kit - White

*Case Qty is 2.



300 SERIES

- Full-size seat and bowl for residential - style comfort
- Triple-jet action cleans the bowl every time
- Uses as little as one pint (0.13 gal/0.5 l per flush)
- Light weight for more mobile uses
- Optional hand sprayer

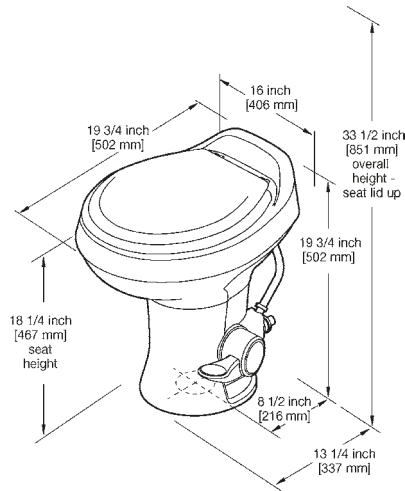

ORDER NUMBER

STANDARD HEIGHT - 18" H

302300071	White
302300073	Bone
302300171	White With Hand Spray
302300173	Bone With Hand Spray

LOW PROFILE - 13.5" H

302301671	White
302301673	Bone
302301771	White With Hand Spray
302301773	Bone With Hand Spray

ACCESSORIES

385311719	Mounting Adapter Kit - White
385311720	Mounting Adapter Kit - Bone
385311718	Water Line Extension Kit
385319054	Hand Spray Kit - White



970 PORTABLE TOILETS 2.6 AND 5.0 GALLON

- Powerful push-button pressurized flush
- Easy-view prismatic tank level indicator
- Adult-size seat and lid provide comfort and safety
- Sizes: 5-gallon (18.9-liter) and 2.6-gallon (9.8-liter) holding tank models
- Mounting brackets and MSD discharge options available

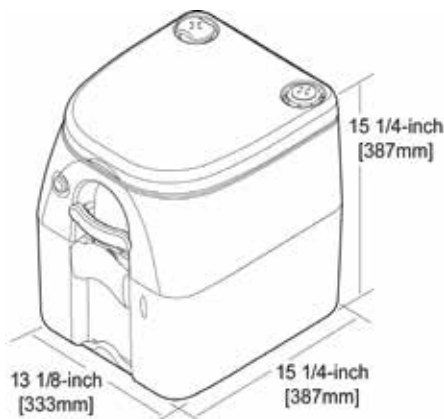

ORDER NUMBER

2.6 GALLON HOLDING TANK

301097202	Tan
301097206	Gray
301097402	Tan with Stainless Steel Hold-down Brackets
301097406	Gray with Stainless Steel Hold-down Brackets
385320005	Hold-down Brackets

5.0 GALLON HOLDING TANK

301097602	Tan
301097606	Gray
301097502	Tan with Stainless Steel Hold-down Brackets
301097506	Gray with Stainless Steel Hold-down Brackets
385320005	Hold-down Bracket



CT4000 TOILET

- Full-size, lightweight plastic toilet with ceramic bowl liner
- Toilet seat rotates 90 degrees in each direction for a wider range of installation options
- Convenient “cassette” waste tank – 5 gal/18.9 l with pull-out flush handle
- Tank slides out from below toilet via a service hatch located outside the RV
- Best selling toilet in Europe



ORDER NUMBER

CT4110US.1	No console, remote mount flush panel
CTS4110US.1	Tall console with flush panel
SK5330360X0310	SK5 Locker Door, 14.17 x 12.2 in/ 360 x 310 mm, white



MASTERFLUSH 7640 RV TOILET

- NEW! RV industry's first pedal-flush macerating toilet
- Powerful macerating flush
- Low (0.17 gpf/0.64 lpf) and Normal (0.67 gpf/2.54 lpf) flush options
- Reduces bathroom odor - no more toilet bowl opening to waste holding tank
- Easy, direct replacement for many RV toilets - mounts to existing floor flange
- Discharge options allow installation in second bathroom located away from waste tank



ORDER NUMBER

304764001	Macerating toilet, pedal-operated flush, White
304764002	Macerating toilet, pedal-operated flush, Bone



CARING FOR YOUR RV AND FOR NATURE
CLEANING

NEW! VENTLESS WASHER DRYER COMBO

The Ventless Washer Dryer Combo gives you the convenience of washing and drying a load of laundry in one machine with no need to cut a vent hole in your RV. Now available in white and black.

- New features: Adjustable drying level & Time saver mode
- LED Display with cycle status indicator
- Compact washer dryer combo
- Continuous wash & dry cycle
- 15 lb (6.8 kg) wash capacity
- Uses 20% less water than competitors
- Easy drainage plug access
- 10 wash cycles with additional rinse & spin cycles
- Programmable frequent user settings
- Load-balancing system
- Ergonomic door handle
- Self-cleaning wash cycle
- Self-cleaning pump
- Water drains to sink, shower, or gray water tank

ORDER NUMBER

WDCVLW2	White
WDCVLB2	Black
D1219001	24ct Oxy Laundry Detergent, 6 per case





GARAGEVAC™

Revolutionary design, wall mounted, space saving vacuum cleaner designed for your garage or shop.

- 9 pounds (4 inches deep)
- 120 volt, 12 amps, 50/60 hz, 415 air watts
- Compact GarageVac™ needs only 3 sq. ft. of wall space
- Integrated tool caddy

ORDER NUMBER

DI-GH120M	Maroon
DI-GH120E	Ebony

ACCESSORIES:

8 piece accessory kit plus 2 bags included

- Installation kit
- 40' flexible hose
- Upholstery tool with removable brush
- Elongated dust brush
- Aluminum telescoping wand
- Bare floor tool
- 24" flexible cCrevice tool
- Short crevice tool
- 5' power cord plugs into any standard power outlet



VACUUM BAGS

- 5 - 5pks per carton
- 5 Genuine bags plus 1 filter

ORDER NUMBER

Y08-5	Fits Dometic/InterVac Models DI-GH, H, F, RM, GH
-------	---



VACUUM BAGS

- 5 - 5pks per carton
- 5 Genuine bags plus 1 filter

ORDER NUMBER

Y11-5	Fits Dometic/InterVac Models CS-8, DI-CS8
-------	--



VACUUM BAGS

- 5 - 5pks per carton
- 5 Genuine bags plus 1 filter

ORDER NUMBER

Y10-5	Fits Dometic/InterVac Models CS-RM, DI-CSRM
-------	--



INTERVAC CENTRAL VAC

Ultra Compact Design. Ideal for the home or RV. Replace your bulky vacuum with this ultra compact system that easily installs under seats, in closets or storage compartments.

- Powerful suction that is ideal for any surface
- Compact design fits any 6" depth
- Easy to use and store

ORDER NUMBER

DI-CS8E

ACCESSORIES:

8 piece accessory kit plus 2 bags included

- Dust brush
- 40' flexible hose with pistol grip
- Crevice tool
- Aluminum telescoping wand
- Mesh storage bag
- Combo rug/floor tool
- Mounting brackets
- Upholstery tool with removable brush
- 2 microfiber bags
- 5' power cord plugs into any standard power outlet



INTERVAC CENTRAL VAC PLUS

Multipoint Design. Ideal for the home or RV. The expandable system allows 2 or more remote hookups and installs easily under seats, in closets or storage compartments.

- 2 inlet valves - allows for multiple hook-up locations
- Banded cuff at inlet to control on/off function
- VacPort™ compatible

ORDER NUMBER

DI-CSRME

ACCESSORIES:

8 piece accessory kit plus 2 bags included

- Dust brush
- 40' flexible hose with pistol grip
- Crevice tool
- Aluminum telescoping wand
- Mesh storage bag
- Combo rug/floor tool
- Mounting brackets
- Upholstery tool with removable brush
- 2 microfiber bags
- 5' power cord plugs into any standard power outlet
- Remote inlet port





VACPORT™

Central vacuum baseboard accessory w/LED light

- Activates with a slight touch of the toe
- Bonus trim plate included
- Compatible w/all central vacuum systems
- Sweep dirt toward the opening & let the power of the vacuum do the rest

ORDER NUMBER

DI-A900ELED VacPort, Quantity: 5 Units per carton

DI-A900ELEDIK VacPort with Installation Kit, Quantity: 1 Unit per carton



24" FLEXIBLE CREVICE TOOL

The flexible design & extra long reach, easily cleans hard-to-reach places.

ORDER NUMBER

DI-X511 Quantity: 5 Units per carton



MINI TURBO BRUSH

Pivoting action for ideal cleaning high traffic areas, pet hair, dirt & dust on all surfaces.

ORDER NUMBER

DI-X451 Quantity: 5 Units per carton

CLEANING AND ODOR ELIMINATION

PREMIUM HOLDING TANK TREATMENT

- Most powerful, longest-lasting control of tank odors without formaldehyde
- Additives break down effluent and help tanks rinse cleaner during pump-out
- Available as a liquid with Tip & Measure Bottle or convenient drop-in packs with recyclable container

ORDER NUMBER

D1110001	12 ct. Drop-In Packs, 6/Case
D1110002	24 ct. Drop-In Packs, 6/Case
D1110003	Trial Size Drop-In Packs, Individually Wrapped, 35/Case
D1111001	4 oz. Trial Size, Liquid, 48/Case
D1111002	32 oz., Liquid, 8/Case
D1111003	1 gal., Liquid, 4/Case
D1111004	4 fl oz. Trial Size Counter Display, 16/Case

3 'N 1 BOWL CLEANER & TANK TREATMENT

- Combines air freshener, bowl cleaner, and tank treatment in one product
- Rapid-dissolving pack releases effervescent cleaner action with air-freshening lavender scent
- Available in a convenient drop-in pack with recyclable container

ORDER NUMBER

D1112001	12 ct. Drop-In Packs, 6/Case
D1112002	24 ct. Drop-In Packs, 6/Case
D1112003	Trial Size Drop-In Packs, Individually Wrapped, 35/Case
D1112004	Trial Size Drop-In Packs, Counter Display, 16/Case

CLEAN 'N GREEN HOLDING TANK TREATMENT

- Advanced, biological formula
- Neutralizes waste tank odors and breaks down effluent naturally
- No fragrances or dyes
- Available in liquid or convenient drop-in packs with recyclable container

ORDER NUMBER

D1114002	12 ct. Drop-In Packs, Recyclable Container, 6/Case
D1113002	32 oz., Liquid, 8/Case

PORTABLE TOILET TANK TREATMENT

- Most powerful control of odors without formaldehyde
- Back-pack ready, 3-pack premeasured foil pouches

ORDER NUMBER

379700066	3 pk. 2 oz. Dry Pouch, 12/Case
-----------	--------------------------------

TOILET TISSUE

- Extra soft & absorbent, breaks up quickly to prevent clogs
- 500 sheets per roll

ORDER NUMBER

379441206	4 pk. - 2 ply Ultra Envrio-Soft™ - 24 Packs Per Carton
379700023	2 ply Ultra Envrio-Soft™ - Individually Wrapped Rolls, 96/Case

GRAY WATER TANK TREATMENT

- Treats gray & black water tanks
- Tank treatment eliminates fume backups

ORDER NUMBER

D1303001	32 oz., Liquid, 8/Case
----------	------------------------

TOILET BOWL & SEAL CLEANER

- Cleans & deodorizes
- Won't stain bowl
- Easy pour spout

ORDER NUMBER

D1216001 26 oz., 8/Case,
Easy Pour Spout

FRESH WATER TANK CLEANER

- Removes stale taste and odor from RV freshwater tank and system
- Chlorine-free formula for safe cleaning
- Concentrated for professional strength
- One bottle treats up to 100-gallons freshwater tank

ORDER NUMBER

D1225001 26 fl oz., 8/Case, Bottle

OXY LAUNDRY DETERGENT

- 4-in-1 stain fighting power
- Brighter colors & whiter whites
- For all laundry machines - including high efficiency
- Convenient drop-in packets

ORDER NUMBER

D1219001 Drop-In Packs, 6/Case,
24-Tub

SLIDE-OUT LUBE & PROTECTOR

- Penetrates and lubricates rusted metal components to reduce friction and wear
- Displaces moisture and prevents corrosion
- Resists road grime and other elements
- Extends rail life by reducing wear and binding during slide-out operation

ORDER NUMBER

D1422001 15 oz., 6/Case, Spray Can

SLIDE-OUT SEAL SAVER

- Conditions and rejuvenates slide-out seals
- Prevents drying, cracking, crazing
- Helps rubber seals resist road grime, weather, UV rays
- Rich foaming formula compatible with rubber seal and surrounding surfaces

ORDER NUMBER

D1426001 15 oz., 6/Case, Spray Can

CONCRETE RENEW

- Safely removes hydrocarbon soils from concrete surfaces
- Bioactive cleaning formula – non-toxic and biodegradable
- Removes motor oil, lubricating grease, transmission fluid, antifreeze and more
- Great for garage floors, parking areas, and other concrete surfaces
- Professional strength

ORDER NUMBER

D1215001 32 fl oz., 8/Case, Bottle

ALL PURPOSE CLEANER

- Citrus-based, multi-purpose cleaner that's safe for all hard surfaces
- Removes built-up grime, black streaks, bugs and much more

ORDER NUMBER

D1205001 32 oz. Spray Bottle, 8/Case

PET STAIN ODOR ELIMINATOR

- Lifts pet stains and eliminates odors
- Safe to use on carpets and upholstery

ORDER NUMBER

D1220001 26 oz. Spray Bottle, 8/Case

ADVANCED A/C COIL CLEANER

- Foam cleaning action penetrates evaporator and condenser coils and fins
- Easy to use on roof-top units, window units, central air and heat exchangers
- Cleans and protects from future debris – no rinsing required
- Helps maximize air conditioning efficiency

ORDER NUMBER

D1227001 32 fl oz., 8/Case, Spray Can

ULTRA HEAVY DUTY CLEANER

- Super-concentrated, multi-purpose cleaner for RV, buildings, concrete, floors, etc.
- Removes built-up grime, grease, black streaks, dirt and road film build-up

ORDER NUMBER

D1204001	Gallon, 4/Case
D1204002	30 Gallon Drum, for Commercial Use
D1204003	55 Gallon Drum, for Commercial Use

RV ROOF CLEANER

- Professional strength for power roof cleaning
- Removes oxidation, black streaks, dirt and road film build-up

ORDER NUMBER

D1202001	Gallon, 4/Case
----------	----------------

ODOR AWAY

- Permanently removes deep down odors
- Great for pet accidents, food spills & more

ORDER NUMBER

D1306001	32 oz. Spray Bottle, 8/Case
----------	-----------------------------

RV WASH 'N WAX CLEANER

- Professional strength, multipurpose wash formula
- Cleans, polishes and protects in one application

ORDER NUMBER

D1207001	Gallon, 4/Case
D1207002	32 oz., 8/Case
D1207003	8 oz. Trial Size Bottle, 24/Case
D1207004	30 Gallon Drum, for Commercial Use
D1207005	55 Gallon Drum, for Commercial Use

RV ROOF SEALER

- Professional strength protectant leaves a silky UV-resistant finish
- Prevents drying, cracking, oxidation; repels rain and dirt

ORDER NUMBER

D1201001	Gallon, 4/Case
----------	----------------

ODOR ABSORB SUPREME

- Breakthrough technology in odor-elimination – neutralizes the harshest odors
- Continuous action lasts up to 2 months

ORDER NUMBER

D1308001	8 oz. container, Counter Display Box, 12/Case
----------	---

AIR FRESHENERS

- Decoratively styled aromatics freshen large interior spaces for months
- 2 Air Fresheners per pack

ORDER NUMBER

D1309001	Spiced Apple, Clip Strip, 6/Case
D1309002	Mountain Air, Clip Strip, 6/Case
D1309003	Fresh Linen, Clip Strip, 6/Case
D1309004	Citrus, Clip Strip, 6/Case
D1309005	Hawaiian Blossom, Clip Strip, 6/Case
D1309006	Cucumber Melon, Clip Strip, 6/Case
D1309007	Spiced Apple, Counter Display, 6/Case
D1309008	Citrus, Counter Display, 6/Case
D1309009	Hawaiian Blossom, Counter Display, 6/Case

PREMIUM RV AWNING CLEANER

- Removes black streaks, bird droppings, mildew, dirt and grime
- Provides ultraviolet (UV) protection

ORDER NUMBER

D1205002	32 oz. Spray Bottle, 8/Case
----------	-----------------------------

BUG REMOVER

- Removes stubborn bug residue and road grime
- Fast-acting formula for efficient cleaning
- Safe on all vehicle surfaces

ORDER NUMBER

D1227501	32oz. Spray Bottle, 8/case
----------	----------------------------

EXPERIENCE HOT SHOWERS IN A COLD FOREST

WATER HEATERS



XT® WATER HEATERS

- 10 gallon water heaters provide the equivalent of 16 gallons of hot water and the six gallon yields 9 gallons
- Durable, powder-coated access doors are included
- Features pre-installed winterizing by-pass kit
- 10 gallon cut-out: 15½" H x 16" W x 20¾" D
- 6 gallon cut-out: 12½" H x 16½" W x 18" D
- 2 Year warranty

ORDER NUMBER

90073	Gas, 6 gal.
90071	Gas/Elec, 6 gal.
94105	Gas, 10 gal.
94026	Gas/Elec, 10 gal.
90068	Gas/Elec w/heat exchanger, 6 gal.
94029	Gas/Elec w/heat exchanger, 10 gal.



ELECTRONIC IGNITION

- 10 gallon output: 10,000 BTUs
- Durable, powder-coated access doors included
- Available in 10,000 BTUs & 8,800 BTUs
- 10 gallon cut-out: 15½" H x 16" W x 20¾" D
- 6 gallon cut-out: 12½" H x 16" W x 18" D
- 2 Year warranty

ORDER NUMBER

96163	GCH6AA-10E, Gas/Elec, 6 gal.
96136	GH6-8E, LP Gas, 6 gal.
96121	G6A8E, LP Gas, 6 gal.
94191	G10-3E, LP Gas, 10 gal.
94022	GC10-4E, Gas/Elec 110V, 10 gal.
94023	GC10A-4E, Gas/Elec 110V



PILOT

- Durable, powder-coated access doors included
- Includes high temperature limit switch, thermostat and pressure/temperature relief valve
- 6 gallon output: 8,800 BTUs
- 6 gallon cut-out: 12½" H x 16½" W x 18" D
- 10 gallon output: 10,000 BTUs
- 10 gallon cut-out: 15½" H x 16" W x 20¾" D
- 2 year warranty

ORDER NUMBER

96110	G6A-7, LP Gas, 6 gal.
94180	G10-2, LP Gas, 10 gal.
96117	GC6AA-8, Gas/Elec 110V, 6 gal.



ELECTRIC WATER HEATERS

- No door required
- 2 year warranty

ORDER NUMBER

96411	Electric with heat exchanger 4 gal. Dimensions 13"H x 13"W x 16"D
93891	Electric with heat exchanger 6 gal. Dimensions 13"H x 13"W x 19¾"D
93882	Electric with heat exchanger 10.5 gal. Dimensions 15¾"H x 15¾"W x 19¾"D



WATER HEATER REPAIR PARTS

ORDER NUMBER

91602	Gas Control valve with thermostat
91604	Relief Valve ½"
90028	Relief Valve ¾"
91367	Potted Circuit Board with fuse - Gas only
91365	Potted Circuit Board with fuse - Combo
91363	Universal Ignition Control Kit
91857	Drain Plug Kit - ½" Plastic (2)
90364	NEW Water Heater Maintenance Kit



REPLACEMENT INNER WATER HEATER TANKS

ORDER NUMBER

91412	Repl. for G6A-2, G6A-3, G6A-6, & G6A-7
91641	Repl. for G6A-4E, G6A-6E, G6A-7E, & G6A-8E Front Mt. T-Stat.
91591	Repl. for GC6AA-7
91059	Repl. for GC6AA-10E
91642	Repl. for GH6-4E, G6A-4E, G6A-7E & G6A-8E Front Mt. T-Stat.
91593	Repl. for GC6AA-7E & GC6AA-8E Screw-in element
91592	Repl. for GCH6A-7E



CONVERSION KIT WATER HEATERS

- Replace Suburban 10, 12 or 16 gallon water heater with the exterior dimensions of 16 7/32" W x 16 7/32" H with an Atwood 10 gallon traditional water heater or an Atwood 10 gallon XT (16 gallon equivalent) water heater 16" wide x 15½" high.

ORDER NUMBER

90362	Atwood Wtr. Htr. Conv. Kit, Black
90374	Atwood Wtr. Htr. Conv. Kit, White



ACCESS DOORS

- Fits Atwood water heaters

ORDER NUMBER

91386	6 gal., Arctic White
91514	6 gal., Colonial White
91385	10 gal., Arctic White
93993	10 gal., Colonial White

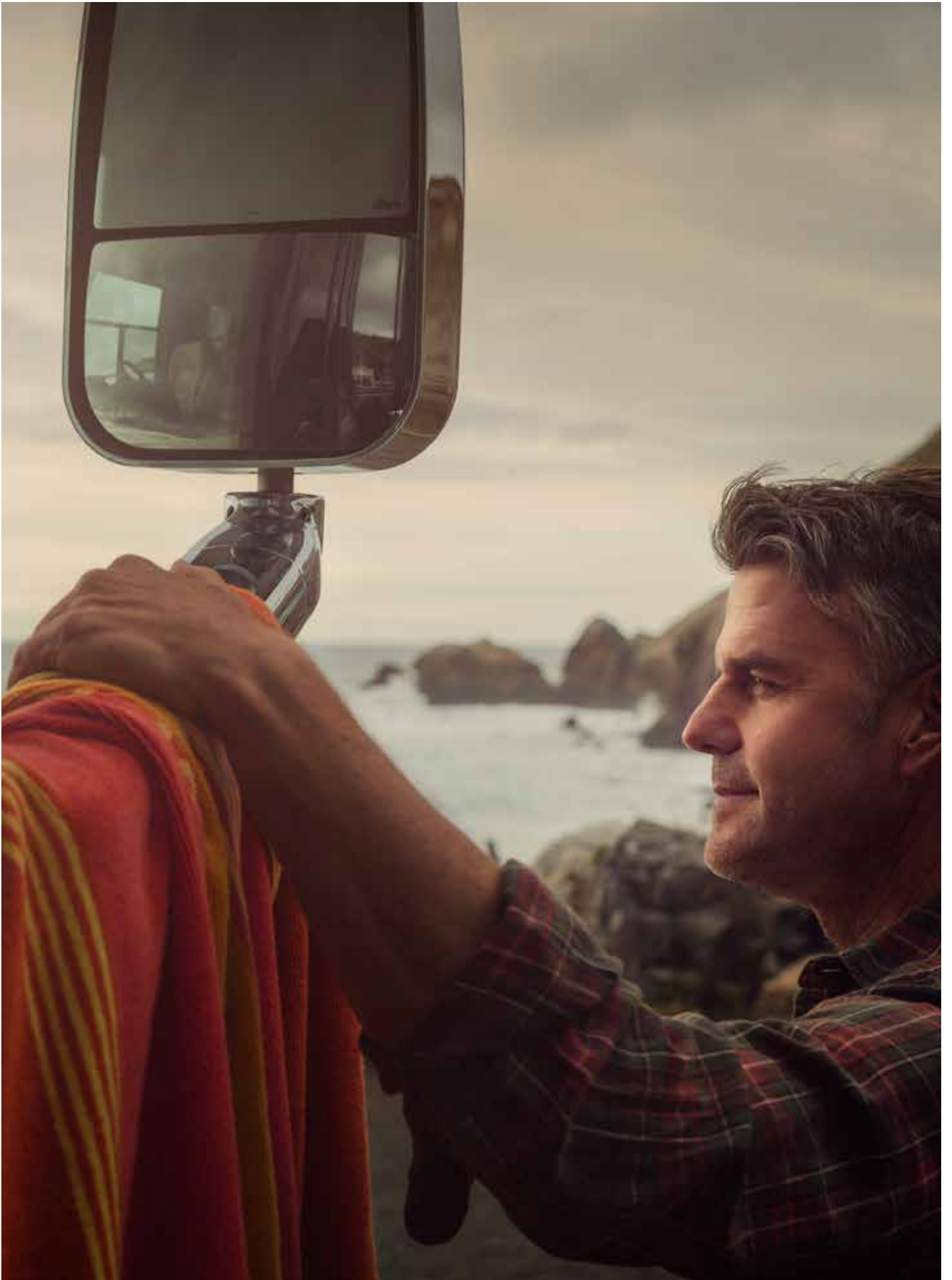

/ DRIVING SUPPORT
/ SAFETY SOLUTIONS

SAFE SECURE





ETY & RITY

ARRIVE SAFELY

DRIVING SUPPORT

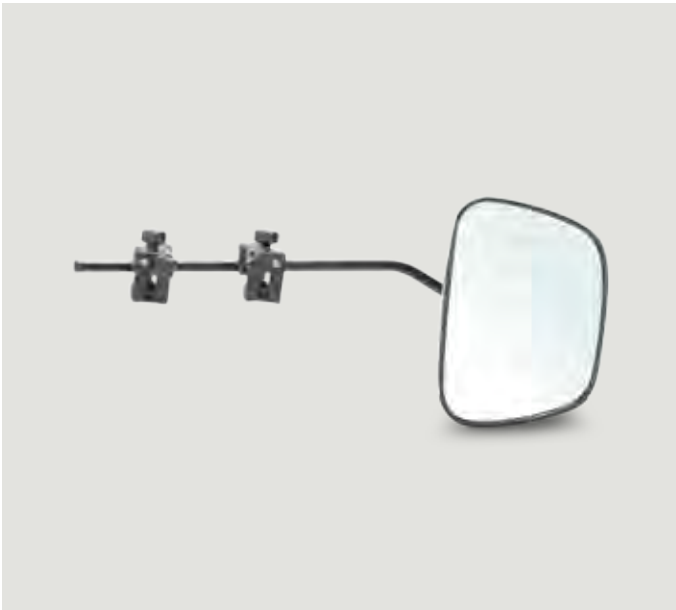

MILENCO GRAND AERO3™ TOWING MIRRORS

- Universal design mounts on all existing mirrors
- Easy grip clamp attachments does not require the use of any tools
- The air balanced design stops vibration
- Wide view mirror includes top to bottom of your towed unit
- The innovative patented design allows the mirror to work with curved mirrors
- Mirrors can be purchased in twin or single packs and replacement parts are available
- Twin pack includes storage bag

ORDER NUMBER

DM-1912	Milenco Grand Aero3™, 4/Case
DM-2912	Milenco Grand Aero3™ Twin Pack, 4/Case



MILENCO AERO3™ TOWING MIRRORS

- Universal design mounts on all existing mirrors
- Easy grip clamp attachments does not require the use of any tools
- The air balanced design stops vibration
- Perfect view adjustment allows the head to rotate 360°
- The innovative patented design allows the mirror to work with curved mirrors
- Mirrors can be purchased in twin or single packs and replacement parts are available
- Twin pack includes storage bag

ORDER NUMBER

DM-1899	Milenco Aero3™, 4/Case
DM-2899	Milenco Aero3™ Twin Pack, 4/Case



MILENCO BLINDSPOT MIRROR

- Superior chrome glass
- Unique Aero clamping system
- Fits flat and curved mirrors

ORDER NUMBER

DM-3100	Milenco Blindspot Mirror, 6/Case
---------	----------------------------------



MILENCO RV LOCKING SECURITY HANDRAIL

- Dual Locking (3 keys included)
- Locks left, right or straight out
- Durable dual foam grip
- Strong powder-coated steel
- Includes complete mounting hardware

ORDER NUMBER

DM-3940 Milenco RV Locking Security Handrail, 2/Case

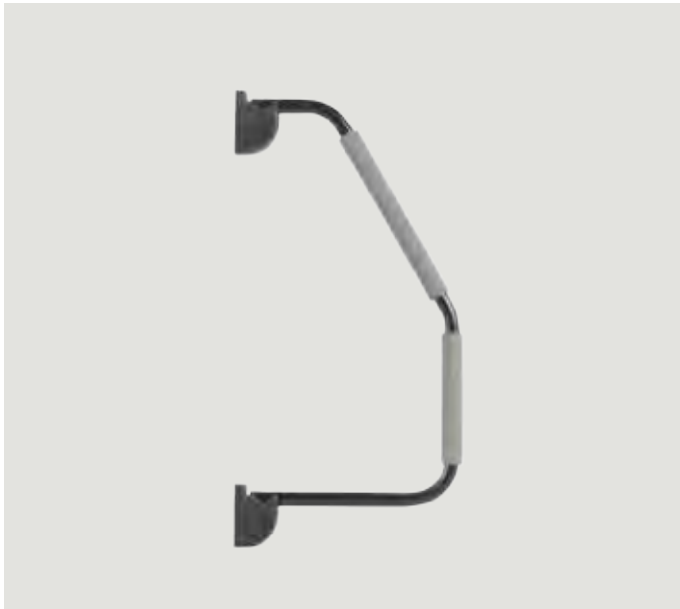

MILENCO RV SAFETY HANDRAIL

- Simply lift up and pull out
- 3 positions left, right or straight out
- Strong powder coated steel
- Durable dual foam grip
- Includes complete mounting hardware

ORDER NUMBER

DM-4565 Milenco RV Safety Handrail, 2/Case



MILENCO SECURITY DOOR LOCK

- Locks from inside or outside
- Ideal theft deterrent
- Fits horizontal or vertical
- Simple to fit with 2 screws
- Robust patented design
- 3 keys included

ORDER NUMBER

DM-4718 Milenco Security Door Lock, 4/Case



MILENCO LOCKING HITCH PIN

- 5/8" Chrome plated steel (fits 2" receiver)
- Usable length 2½"
- Perfect fit for Class I-IV, 10,000 lb. max load rating
- Locking design with 3 keys

ORDER NUMBER

DM-4985	Milenco Locking Hitch Pin, 6/Case
---------	-----------------------------------



MILENCO REPLACEMENT PARTS

ORDER NUMBER

DM-1953	Aero3™ Mirror Pads
DM-1984	Aero3™ Mirror Head
DM-2493	Grand Aero3™ Mirror Head
DM-4589	Aero3™ Mirror Clamp



SOME DANGERS DON'T GROWL FIRST

SAFETY SOLUTIONS



CARBON MONOXIDE GAS ALARMS

Protect you and your family from the dangers of carbon monoxide gases. The Atwood CO alarm is less sensitive to humidity and “false” gases than other brands. Includes a loud alarm, digital display and patented fuel cell technology powered by batteries to utilize a more accurate sensor. Approved for ceiling mount applications. Includes three AA batteries. Industry leading 10 year life cycle.

ORDER NUMBER

32701	Non-Digital Alarm Gas CO White 5 Year Warranty
32703	Digital Alarm Gas CO White 7 Year Warranty



DUAL LP/CO ALARMS

Why have two separate alarms when you can have just one? Single unit detects both LP and CO gases! Uses chassis and battery power to help protect your family. Operates in six separate modes. ETL listed and tested to UL 2034, UL 1481 and CSA 6.19.00 for RV Applications.

ORDER NUMBER

36681	Dual LP/CO Alarm 12V White
31012	Dual LP/CO Alarm 12V Black
36689	Surface Mt. Box White
31128	Surface Mt. Box Black



LP GAS DETECTORS

Designed for tough RV environments, the Atwood LP Sensor alerts you to low concentrations of LP gas through red and green LEDs. If gas exceeds 2,000 ppm, a loud piercing alarm will sound. CSA listed. Adapter mount ring allows detector to fit the 3 7/8” x 3 1/8” cutout from the last generation of flush mount Atwood LP detectors.

ORDER NUMBER

36720	12V DC Power White
31014	12V DC Power Black



ORDER NUMBER

MD390RH

MOBILE ELECTRONIC SAFE

A Secure Location For Your Valuables. The Dometic Mobile Electronic Safe is perfect for storing your valuables when you are on the road.

- Large enough for 17 in / 43 cm laptop
- Multi-function LED display
- Program with any 4- to 6-digit combination
- Emergency access keys (2 included), overrides combination
- Mounting kit included for secure installation
- Cushioned felt padding
- Powder-coated steel finish
- 2-year limited warranty
- Uses 4 AA batteries (not included)
- Protects valuables
- Simple to operate
- Emergency access key overrides combination
- Easy to install from top or bottom
- Bright interior LED light

PRODUCT SPECIFICATIONS

Overall Dimensions: 15.4 x 7.9 x 18.5 in | 39.1 x 20.1 x 47 cm (W x H x D)
Weight: 31 lbs | 14kg
Capacity: 1.05 cubic ft | 29.7 liters
Door Thickness: 0.08 in | 2 mm
Cabinet Thickness: 0.2 in | 5 mm
Display: Illuminated LED
Color: Anthracite Grey



ORDER NUMBER

LPGC10

LP GASCHECKER™

Quick & Easy Check Of Your LP Gas Level. Make life easier when you use liquid propane gas for appliances in your camper, RV, boat, or home. The LP GasChecker tells you in just a few seconds how full—or empty—a propane tank is.

- Ultrasonic technology
- Easy to use
- About the size of a writing pen
- Weighs less than an ounce
- For all commonly available steel and aluminum liquid propane tanks with a diameter of 8 to 14 in (203 to 356 mm).
- Provides a reliable measurement of gas level in propane tanks
- For use on steel and aluminum liquid propane tanks
- Available in 10-pack counter display

PRODUCT SPECIFICATIONS

Overall Dimensions: 4.4 x .63 in | 112 x 16mm (L x W)
Weight: 0.88 oz | 25 g



MOBILE LIVING MADE EASY

As you will notice, Dometic is changing and has completed a global rebranding initiative. While there are many elements that will be immediately visible to you; like the new logo, new colors and new packaging. There are also quite a few exciting things behind the scenes that will become more visible in the coming months, including the new Dometic.com.

The new Dometic is one company, one brand, one promise. That promise is to provide smart, reliable products with outstanding design in the areas of Food & Beverage, Hygiene & Sanitation, and Climate Control to make mobile living easy.

While some of our familiar sub brand names like Atwood, Fan-Tastic Vent and SeaLand will be eliminated, the products, ingenuity and legacy remain. This initiative allows us to harmonize Dometic's resources into one cohesive global company. Therefore, we can unify all of the 22 manufacturing facilities, countless warehouses and our 6,500 employees to provide an even higher level of service, support and product excellence.

ONLINE SERVICE AND SUPPORT

Our unique online support system helps dealers order products, manage their account, and obtain essential product information quickly and easily.

To access Dometic's online order entry and customer support log onto www.eDometic.com and register for an account. Once you set a username and password you will be able to enter orders, check order status, look up spare parts and find out about the latest promotions and Dometic product news.

SMART SOLUTIONS, RELIABLE PRODUCTS, OUTSTANDING DESIGN

Dometic's job is to take care of our customers essential needs while living mobile. Therefore, we continue to develop new and innovative products, while improving our existing lines.

- We have added additional models to the already robust CFX line of portable refrigerator / freezers, including the CFX 100 and the CFX 65 single zone.
- You will also notice a new look to the CFX products, in addition to many of the models now having Wi-Fi capability to allow for connectivity to a new App which can be accessed by utilizing iOS or Android smart devices.
- Additional new, innovative products have been added to this years catalog including; the CC-32 Portable Refrigerator / Freezer, the new Ventless Washer / Dryer Combo and further items added to the cleaning and odor elimination.

KEY INFORMATION TO REMEMBER

- Online order entry, customer support and dealer locator: www.eDometic.com
- Dometic Image Bank: www.dometic.com/imagebank
- Dometic product information: www.dometic.com
- Phone: 800.366.3842
- Fax: 574.294.8628
- Email: FDD@dometicusa.com



FDD CUSTOMER SERVICE
1120 N. MAIN STREET
ELKHART, IN 46516
800.366.3842
WWW.DOMETIC.COM
L4676 - 11.07.16

 **DOMETIC**