



PVI 36TL

INSTALLATION AND OPERATION MANUAL

Revision B

©2015, Yaskawa- Solectria Solar



IMPORTANT REGISTRATION AND WARRANTY INFORMATION

For warranty to become active, this inverter must be registered. To activate warranty and register inverter, please visit the link below.

www.solectria.com/registration

Before You Start...



This manual contains important information regarding installation and safe operation of the PVI 36TL. Be sure to read this manual carefully before using the inverter.

Thank you for choosing a Solectria grid-tied PV Inverter. This PV Inverter is high performance and highly reliable product specifically designed for the North American Solar market.

If you encounter any problems during installation or operation of this unit, first check the user manual before contacting your local dealer or supplier. This user manual is applicable for the following model: PVI 36TL.

Instructions inside this user manual will help you solve most installation and operation difficulties. Contact your local supplier if the problem still exists.





Please keep this user manual on hand for quick reference.

IMPORTANT SAFETY INSTRUCTIONS



SAVE THESE INSTRUCTIONS

Please read this user manual carefully before product installation. Solectria reserves the right to refuse warranty claims for equipment damage if the user fails to install the equipment according to the instructions in this manual.

Warnings and Symbols in this Document

	<p>DANGER: DANGER indicates a hazardous situation which, if not avoided, will result in death or serious injury.</p>
	<p>WARNING: WARNING indicates a hazardous situation which, if not avoided, could result in death or serious injury.</p>
	<p>CAUTION: CAUTION indicates a hazardous situation which, if not avoided, could result in minor or moderate injury.</p>
	<p>NOTICE: NOTICE indicates a hazardous situation which, if not avoided, could result in equipment working abnormally or property loss.</p>
	<p>INSTRUCTION: INSTRUCTION indicates important supplementary information or provides skills or tips that can be used to help you solve a problem or save you time.</p>

Markings on the Product

	<p>HIGH VOLTAGE: This inverter works with high voltages. All work on the product must only be performed as described in this document.</p>
	<p>HOT SURFACE: The equipment is designed to meet international safety standards, but surfaces can become hot during operation. Do not touch the heat sink or peripheral surfaces during or shortly after operation.</p>

	<p>EARTH GROUND: This symbol marks the location of grounding terminal, which must be securely connected to the earth through the PE (Protective Earth) cable to ensure operational safety.</p>
---	---

**WARNING:**

All of the installation and wiring connections should be performed by qualified technical personnel. Disconnect the inverter from PV modules and the AC Grid before maintaining and operating the equipment.

Follow all local, national or country specific guidelines for electrical safety.

**DANGER:**

Please disconnect the inverter from the AC grid and PV modules before opening the equipment. Make sure hazardous high voltage and energy inside the equipment has been discharged.

Do not operate or maintain the inverter until at least 5 minutes has passed after disconnecting all sources from DC and AC sides.

**CAUTION:**

PVI 36TL inverter is approx. **66kg (145 pounds) including the wiring box.**

Please ensure the mounting bracket is properly installed before hanging the inverter on the bracket.

**INSTRUCTION:**

Please check with your local electricity supply company before selecting a grid standard. If the inverter is operated with a wrong grid standard, the electricity supply company may cancel the interconnection agreement.

Putting the inverter into operation before the overall system complies with the national rules and safety regulation of the application is not permitted.

SAVE THESE INSTRUCTIONS

Table of Contents

1.0 Overview..... 7

 1.1 Inverter for Grid-Tied PV Systems 7

 1.2 Product Features 7

 1.3 Product Protection Functions 8

 1.4 Circuit Structure Design 8

 1.5 Appearance Description 9

 1.6 Anti Islanding 9

 1.7 DC Ground Fault Protection..... 10

 1.8 Surge Suppression 10

2.0 Installation 10

 2.1 Recommendations before Installation 12

 2.2 Mechanical Installation..... 13

 2.3 Electrical Installation 24

 2.4 Inverter Communication Connections.....41

3.0 Commissioning 58

 3.1 Commissioning Checklist 58

 3.2 Commissioning Steps..... 58

4.0: User Interface..... 60

 4.1 Description of LCD 60

 4.2 Operation State 61

 4.3 Interface Types 61

 4.4 Menu functions 63

5.0: Operation..... 79

 5.1 Start-up..... 79

 5.2 Shutdown..... 79

 5.3 Operation Mode 79

 5.4 Grid-Tied Power Generation..... 81

6.0: Maintenance and De-Installation 82

6.1 Fault Shutdown and Troubleshooting 82

6.2 Product Maintenance 87

6.3 Uninstalling the Inverter 92

7.0: Technical Data 93

8.0: Accessory Options 97

8.1 Fuse Bypass..... 97

8.2 SolrenView Monitoring..... 98

8.3 Shade Cover 98

8.4 AC & DC Disconnect Covers 101

9.0: Appendices: 102

Appendix A – Instruction of Inverter Selection 102

Appendix B – PVI 36TL Datasheet..... 106

Appendix C – String Sizing Tool..... 106

Appendix D – Contact Information..... 106

Appendix E – Authorized Distributors 106

Appendix F – UL 1741 / UL 1699B/ IEEE 1547 / CSA 22.2#107.1
 Authorization to Mark 107

1.0: Overview

1.1 Inverter for Grid-Tied PV Systems

The PVI 36TL inverter is suitable for use for commercial and large scale PV grid-tied systems. A system is generally made up of PV modules, DC power distribution equipment, PV inverter and AC power distribution equipment (Figure 1.1). The inverter converts DC from PV modules to AC with the same frequency and phase as the AC grid. All or part of the AC power is supplied to local loads, and the surplus power is supplied to the electricity grid.

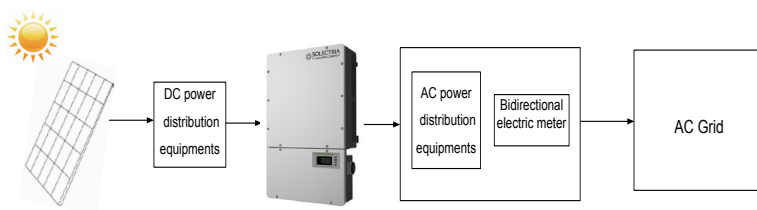

Figure 1.1 - Grid-Tied PV System

1.2 Product Features

- ◆ **High Conversion Efficiency:** Advanced 3-level conversion technology; Max. efficiency: 98.4% ; CEC efficiency: 98.0%
- ◆ **Strong Grid Adaptability:** 7 grid standards applicable; Reactive power adjustable; Power Factor (PF) value: ± 0.8 , Remote Curtailment
- ◆ **Flexible Communication:** Supports standard Modbus communications to ensure compatibility with 3rd party monitoring and control systems
- ◆ **Wide DC Input Voltage Range:** Operating DC Input Voltage Range: 200-950Vdc; Max DC input voltage: 1000V
- ◆ **Long Service Life:** Uses thin-film capacitors to extend inverter's service life
- ◆ **2 MPPTs:** Dual and independent MPPT (Maximum Power Point Tracking) enable maximum design flexibility and optimize energy harvest over the life of the system
- ◆ **High Protection Degree:** NEMA 4X protection degree meets the needs of both indoor and outdoor use;
- ◆ **Intelligent Integration:** Embedded DC/AC switches and up to 8 fused string inputs eliminates the need for external combiner boxes and simplifies installation.

1.3 Product Protection Functions

- ✓ Reverse polarity protection of DC input
- ✓ Short circuit protection
- ✓ Arc-Fault Circuit Interruption
- ✓ Anti-islanding protection
- ✓ Input and output over-voltage protection
- ✓ Input over-current protection
- ✓ Monitoring of DC input insulation against ground
- ✓ Monitoring of AC output voltage and frequency
- ✓ Monitoring of Leakage current against ground
- ✓ Monitoring of DC injection from AC output
- ✓ Monitoring of ambient temperature
- ✓ Monitoring of IGBT module temperature

1.4 Circuit Structure Design

The basic schematic diagram of PVI 36TL inverter is shown in Figure 1.2. The input of PV modules passes through surge protection circuitry, DC EMI wave filter, and the front-end boost circuitry to achieve maximum power tracking and boost up voltages. The output of the inverter converts the DC voltage to 3-phase AC voltage. The high frequency AC components are removed with a wave filter. Then the 3-phase AC voltage is passed through two-stage relays and EMI wave filter to produce high quality AC power.

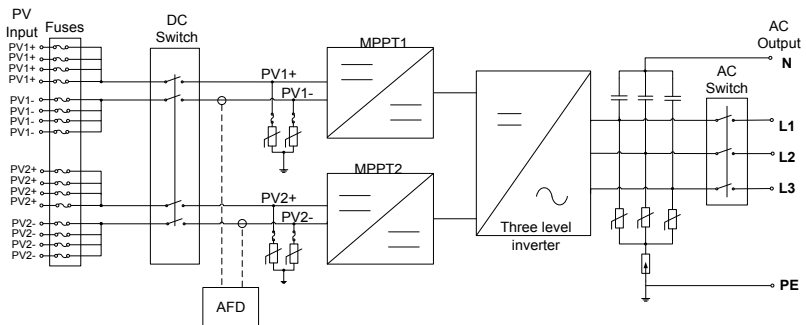

Figure 1.2 - Schematic Diagram of PVI 36TL Inverter

1.5 Appearance Description

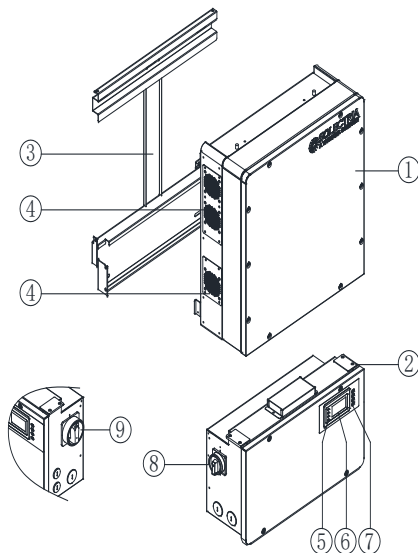

Figure 1.3 - Sketch of PVI 36TL Inverter

Main Items of the Inverter:

- 1) Main inverter section
- 2) Wiring box of the inverter
- 3) Mounting bracket
- 4) External cooling fans
- 5) LED indication lights
- 6) LCD
- 7) Key buttons
- 8) DC switch: DC power on/off
- 9) AC switch: AC power on/off

1.6 Anti Islanding

This inverter includes Active Anti-Islanding detection as required by UL1741/IEEE1547. The inverter will automatically make small variations in reactive power output in order to detect a possible islanding condition. If the grid is stable, these small variations will have negligible effects on system voltage and frequency.

However, in an islanded condition the small amount of reactive power changes will force the system voltage or frequency to change significantly, which will trigger the inverter to shut down.

1.7 DC Ground Fault Protection

The PVI 36TL includes residual current detection as part of the DC ground fault detection method as required by UL1741. If there is a ground fault in the array, the ground fault detection technology will detect the array leakage current. The inverter will shut down if the leakage current exceeds 500mA.

1.8 Surge Suppression

STANDARD WAVEFORM PEAK VALUES		
Surge Category	Ring Wave	Combination Wave
B	6 kV/0.50 kA	6 kV/3 kA

- "Standard 1.2/50 μ s - 8/20 us Combination Wave"
- "Standard 0.5 μ s - 100 kHz Ring Wave"

1.9 DC Arc Fault Detection

The PVI 36TL includes DC Arc fault detection compliant with UL 1699B. The inverter detects electrical noise that typically accompanies a DC series arc. The inverter will shut down should the arc fault sensor detect a series arc. See section "Arc fault current interruption" for more details.

2.0: Installation

Below is the installation procedure for the inverter. Please read carefully and install the product step-by-step.

Before installation, please check that the following items are included in the package:

Table 2.1 - Main Items

No.	Item	Qty	Note
(1)	Main inverter section	1	

(2)	Wiring box	1	
(3)	Mounting bracket	1	Upon which inverter is hung and mounted onto a wall
(4)	User manual	1	Installation and operation manual
(5)	Accessory kit	1	Contains all necessary accessories

The (5) Accessory kit contains items listed below:

Table 2.2 - Accessories

No.	Item	Qty	Note
(1)	M8 Expansion tubes	8	For mounting bracket
(2)	M8x25 assembling bolts	8	For mounting bracket
(3)	M6 X16 screw	6	For wiring box and main section; 2 spare parts
(4)	M5X10 screw	10	8 for mounting bracket and inverter, external ground connection; 2 for installing jumper busbar.
(5)	M5 flange nut	2	For internal ground stud connection; 1 spare part
(6)	Lifting eye nut M10	2	For lifting the main section
(7)	OT type terminal	2	For ground connection
(8)	Pre-insulated end ferrule for AC side (4 AWG)	5	For AC output cables, 1 spare part
(9)	Pre-insulated end ferrule for grounding (8AWG)	8	For AC ground cables
(10)	Pre-insulated end ferrule for DC side (10 AWG)	20	For DC input cables, 4 spare parts

(11)	RJ45 connector	4	For RS-485 or Ethernet communication, 2 spare parts
(12)	5 pin connector	1	For RS-485 communication
(13)	3 pin connector	1	For dry contact communication
(14)	Jumper busbar	2	For parallel mode use

**INSTRUCTION:**

The items in the accessory kit table above are for the standard configuration. The accessories may vary if optional parts are purchased.

2.1 Recommendations before Installation

- ✓ Check that the product environmental specifications (protection degree, operating temperature range, humidity and altitude, etc.) meet the requirements of the specific project location;
- ✓ Make sure that the AC grid voltage is within the normal range.
- ✓ Ensure that the local electricity supply authority has granted permission to connect to the grid.
- ✓ Installation personnel must be qualified electricians or people who have received professional training.
- ✓ Sufficient space according to Figure 2.3 should be provided to allow the inverter cooling system to operate normally.
- ✓ Install the inverter away from flammable and explosive substances.
- ✓ Avoid installing the inverter in locations that exceed the temperature limits specified in the inverter data sheet to limit undesirable power loss.
- ✓ Do not install the inverter near the electromagnetic source which can compromise the normal operation of electronic equipment.

2.2 Mechanical Installation

1) Dimensions

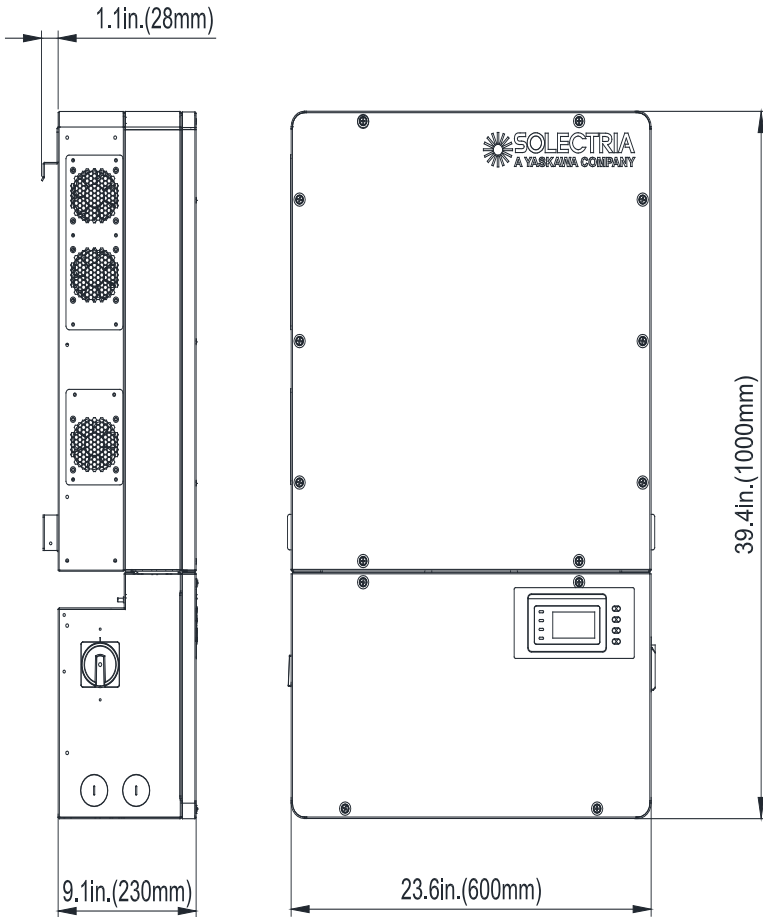

Figure 2.1 - PVI 36TL Inverter Dimensions

2) Installation Method (see Figure 2.2):

Make sure that the mounting structure (wall, rack, etc.) is suitable to support the inverter weight. Follow the mounting guidelines below:

- (a) If the location permits, install the inverter vertically.
- (b) If the inverter cannot be mounted vertically, it may be tilted backward but no lower than 15 degrees from horizontal.
- (c) Do NOT mount the inverter leaning forward.
- (d) Do NOT mount the inverter in a horizontal position (<15 degrees).
- (e) Do NOT mount the inverter upside down.

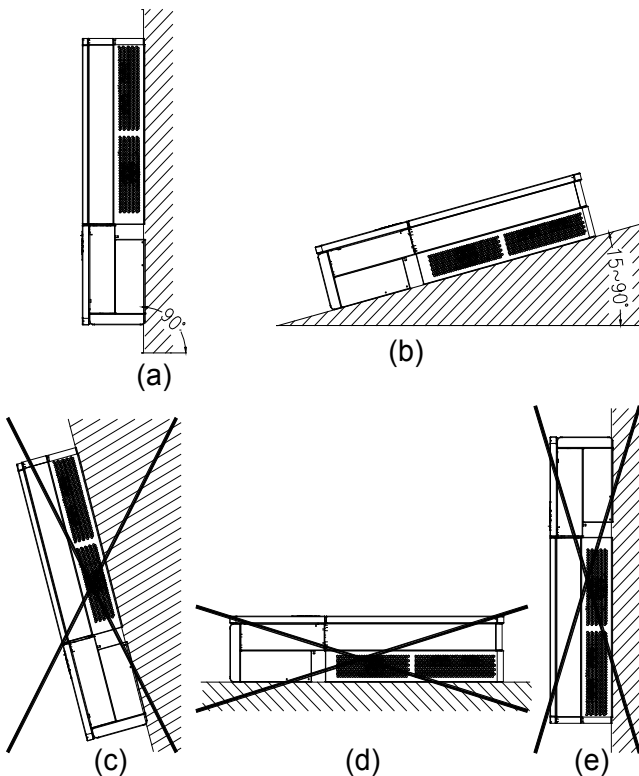

Figure 2.2 - Inverter Mounting

NOTICE:

When the inverter is mounted at an angle $\leq 15^\circ$ outdoor, shade cover is recommended to be installed above the inverter to avoid direct sunlight.

3) Installation Space Requirement (see Figure 2.3):

The distances between the inverters or the surrounding objects should meet the following conditions:

**NOTICE:**

The spacing between two adjacently mounted inverters should be $\geq 500\text{mm}$ (19.7 inches). Ensure that the air space around the inverter is well ventilated.

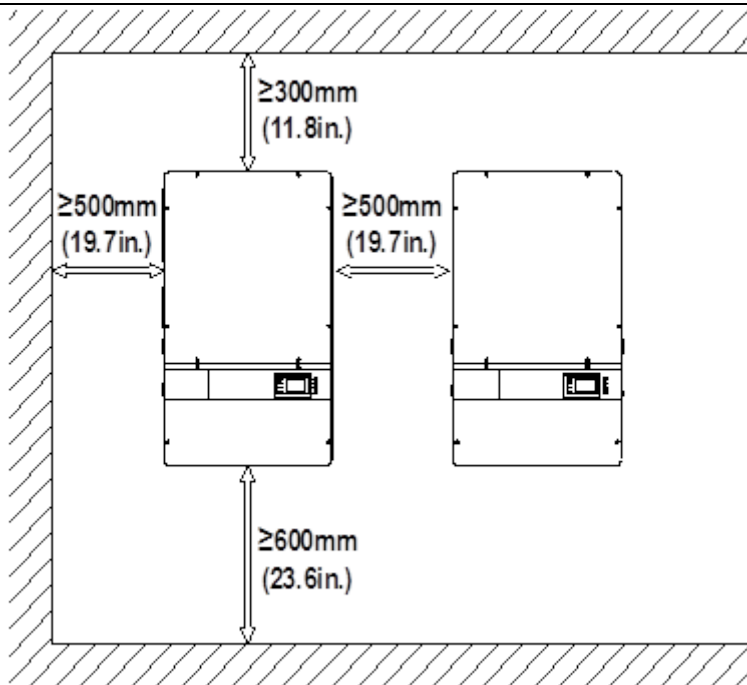

Figure 2.3 - Inverter Wall Mounting Specifications

**NOTICE:**

The installation clearance between two inverters needs to be increased to 30 in. when the ambient temperature is higher than 45°C .

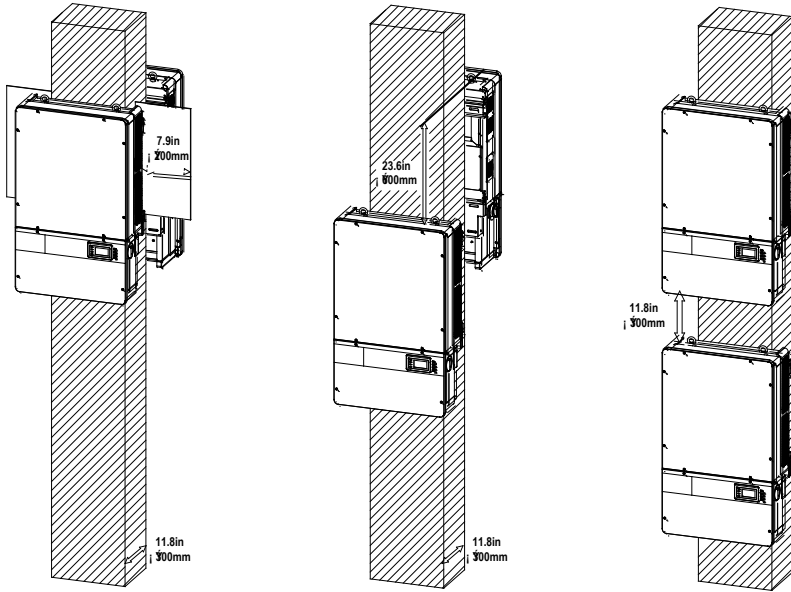

Figure 2.4 - Inverter Pillar Mounting Specifications



INSTRUCTION:

If the inverter is installed on Unistrut or the array racking (instead of solid wall), the space from the bottom of one inverter to the top of the inverter below may be as small as 4in (100mm).

4) Mounting the Inverter Onto the Bracket

(1) Mark the 8 holes on the bearing surface for mounting the bracket as shown in Figure 2.5;

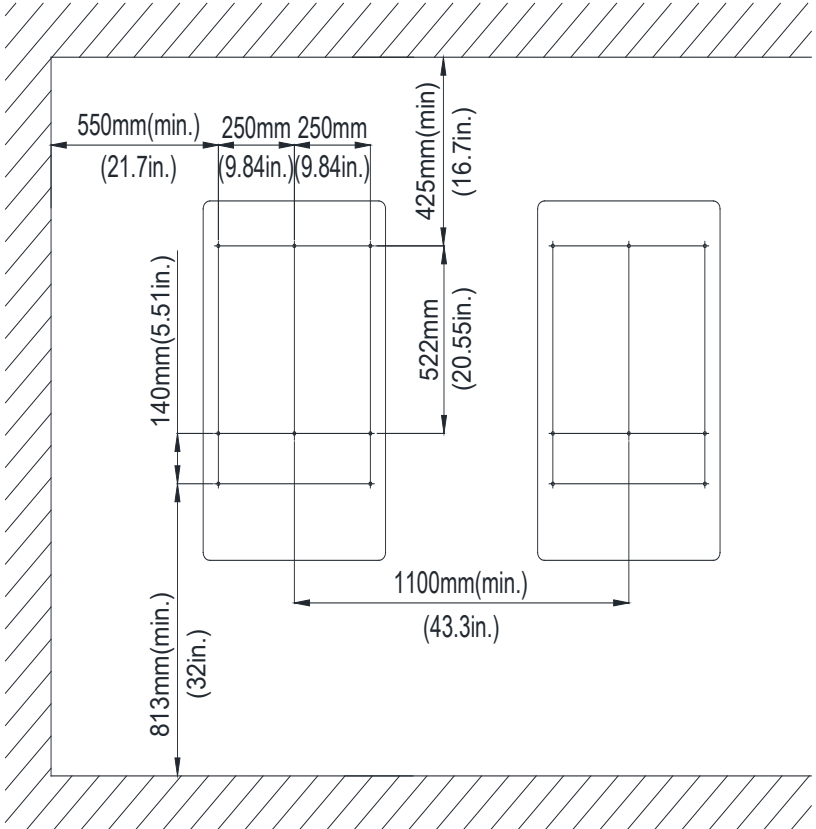

Figure 2.5 - Holes on the Bearing Surface Dimensions

(2) Drill holes at the marked positions with a 10mm (0.4in.) drill and put the **M8 expansion tubes** ① into the holes; fasten the **mounting bracket** ② with the **M8x25 assembling bolts** ③ in the accessory kit. Figure 2.6.

Tool: Electric drill (Φ 10mm/0.4in. head), 13mm wrench 240 in-lbs

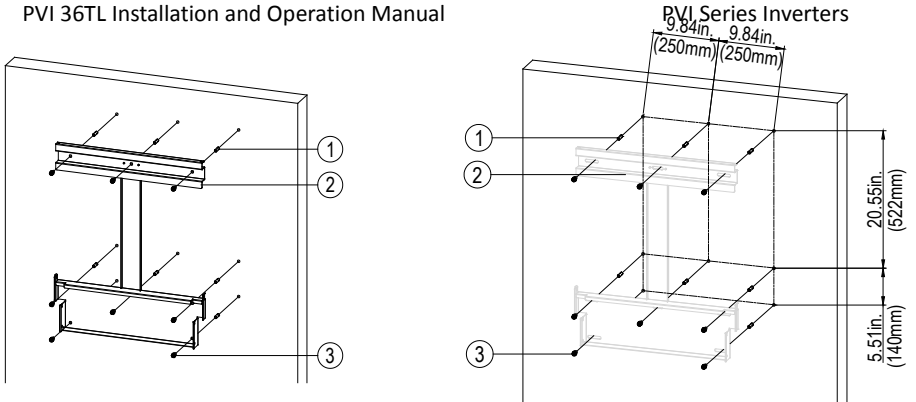

Figure 2.6 - Securing the Mounting Bracket

(3) Hang the inverter onto the mounting bracket as shown in Figure 2.7 and Figure 2.8;

Lift mounting: Take out the **lifting eye nut M10 (2pcs)** from the accessory kit, and screw them onto the studs at the top of the inverter. Use a sling rope or bar (inserted through both lifting eye nuts) to lift the inverter onto the bracket. The minimum angle between the two sling ropes should be less than 90 degrees.

Manual mounting: Two people are needed to properly lift the inverter by the handles detailed in Figure 2.8, and mount the inverter onto the bracket.



CAUTION:

The main PVI 36TL inverter section is **55kg (≈122 pounds)**.

Please ensure the mounting bracket is properly installed before hanging the inverter on the bracket. It is recommended to have at least 2 people to mount the inverter due to the weight of the equipment.

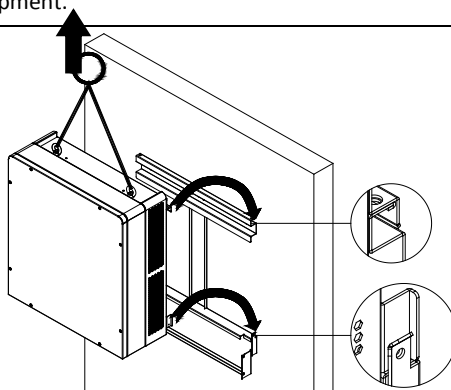

Figure 2.7 - Mounting the Main Inverter Section on the Bracket

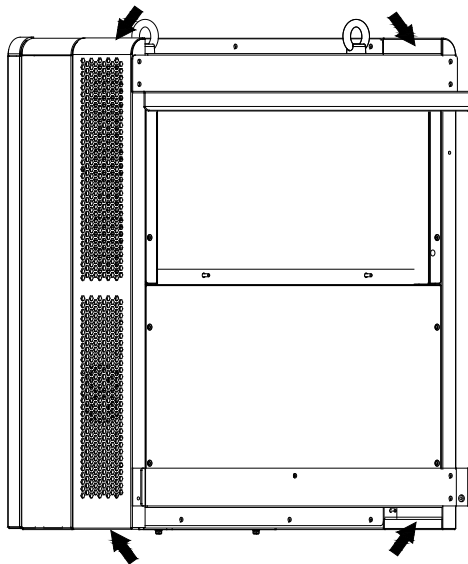

Figure 2.8 - Grab Handle Position

(4) Installing the wiring box

- ① Remove the cover plate at the bottom of the main section. (see Figure 2.9)

Tool: No.2 Phillips head screwdriver

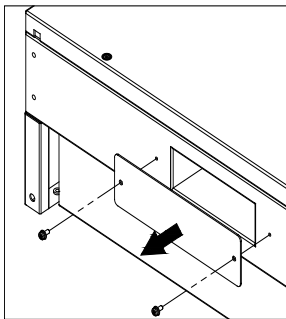

Figure 2.9 – Main Section Cover Plate

- ② Remove the cover at the top of the wiring box (see Figure 2.10)

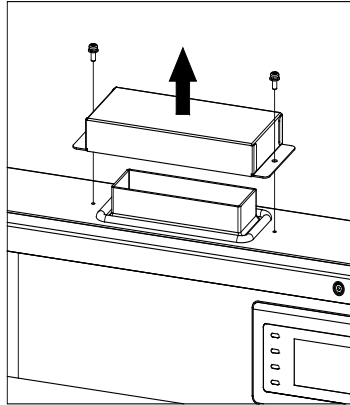

Figure 2.10 - Wiring Box Cover

③ Connect the wiring box to the main section, using M6x16 screws (4pcs) to secure the wiring box. (see Figure 2.11)

Tool: No. 10 Wrench, torque value of 25 in-lbs (2.8N.m)

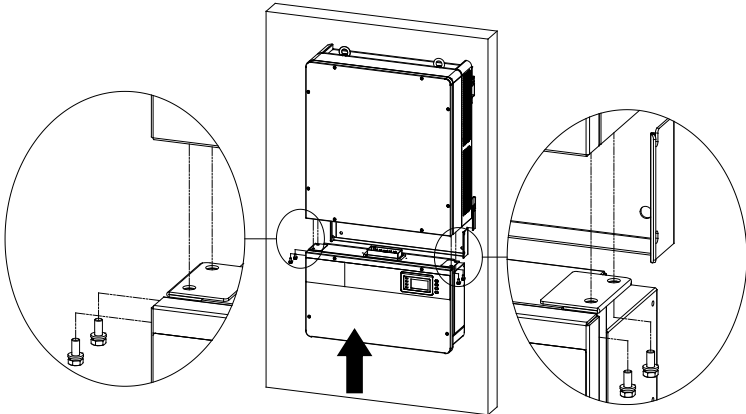

Figure 2.11 - Wiring Box Installation



CAUTION:

The total weight of the PVI 36TL main inverter section and wiring box is 66kg (146 pounds).

(5) Attach the main section and the wiring box to the mounting bracket with the **M5x10 bolts** (6 pcs). (see Figure 2.12)

Tool: No.2 Phillips head screwdriver, torque value of 1.6N.m (14 in-lbs)

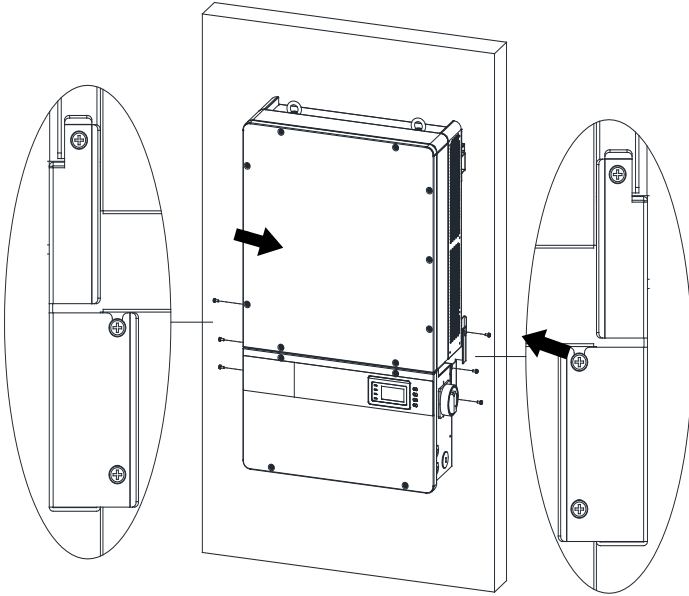

Figure 2.12 - Secure the Main Section and Wiring Box to the Bracket

(6) Optional - Install an anti-theft padlock when the installation is complete. The anti-theft padlock is used to help prevent the inverter from being stolen when the equipment is installed outdoors. You can lock the inverter on the bracket, as shown in Figure 2.14:

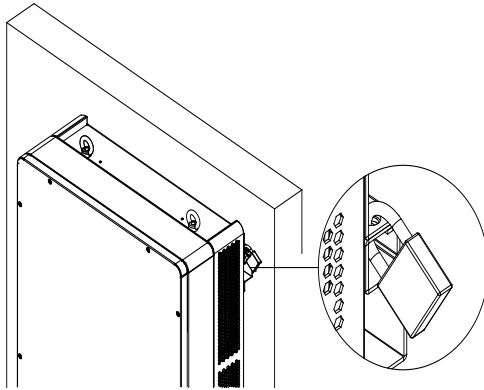
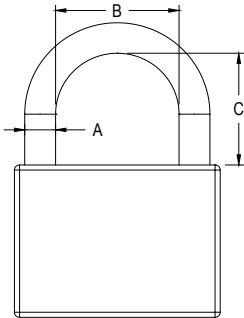

Figure 2.13 - Anti-Theft Padlock Location

The anti-theft padlock should meet the requirement of the dimensions shown in Figure 2.14:



Recommended lock size:

A: $\Phi 3\sim 6\text{mm}$

B: $20\sim 50\text{mm}$

C: $20\sim 50\text{mm}$

Figure 2.14 - Dimensions of Anti-Theft Padlock

5) Removing/Replacing the Wire Box Cover:

- (1) Use a #3 Phillips screwdriver to remove the 4 screws on the wiring box and pull cover straight off the box. Do not twist or slide the cover while removing. (see Figure 2.15)

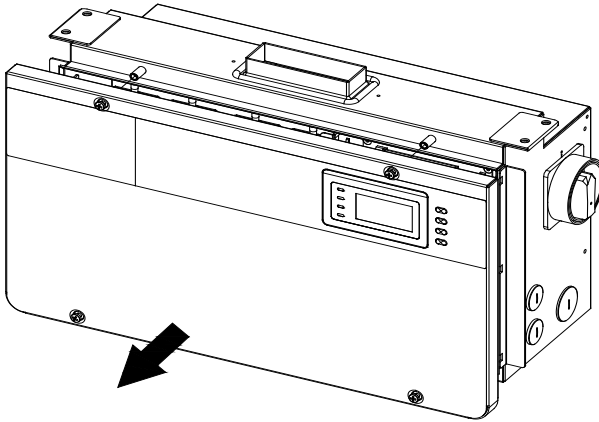

Figure 2.15 – Removing the Wiring Box Cover

(2) To replace the cover use a #3 Phillips screwdriver to replace the 4 screws on the cover.



INSTRUCTION:

It is important to use a hand tool (e.g. Screwdriver or T-handle, #3 Phillips) and not power drivers or other types of screw drivers. Also, it is important to hold the cover in alignment with balanced force across the cover, not weighted toward any edge. Partially engage all four screws to the threaded inserts a few rotations before tightening any one screw. This is important to maintain alignment and avoid thread damage. When all four screws are engaged torque to 20 in-lbs (2.2Nm).

2.3 Electrical Installation

The connection interface of PVI 36TL inverter:

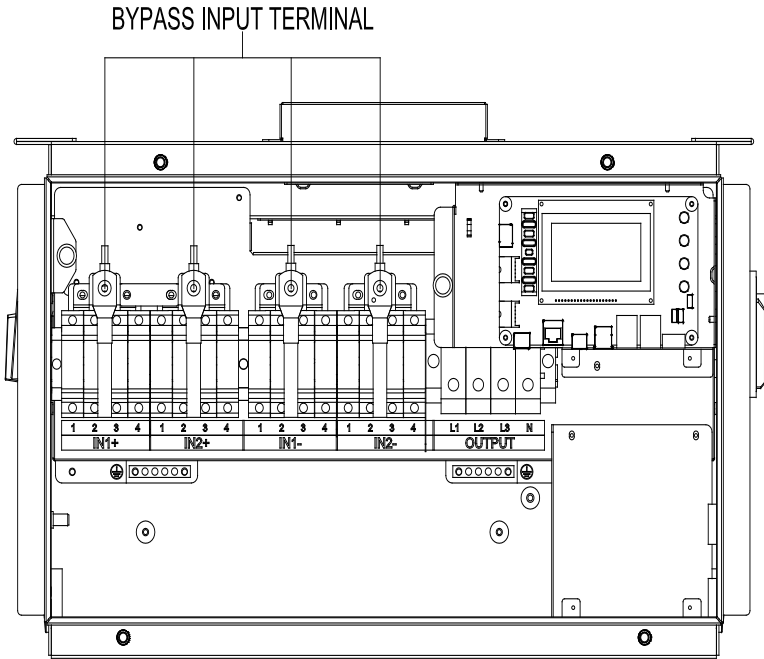

Figure 2.16 - Full View of Wiring Box with Options

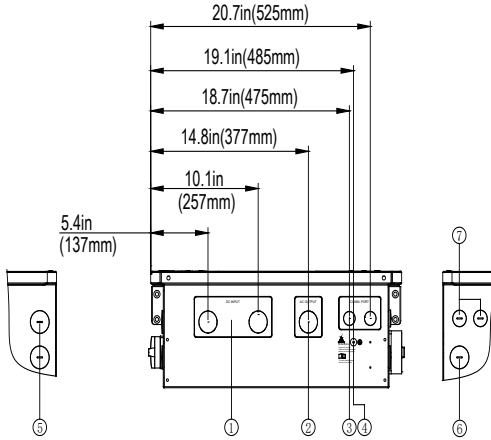

Figure 2.17 - External Connection Ports

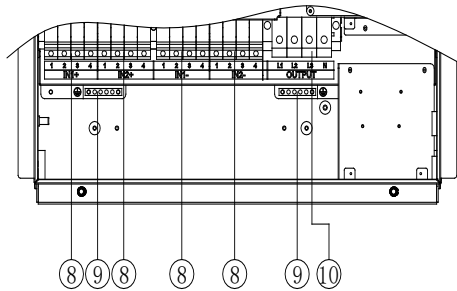

Figure 2.18 - Internal Connection Points

1. Knockout for DC input cable, 1-1/4inch
2. Knockout for AC output cable, 1-1/4inch
3. Knockout for communication cable, 3/4inch
4. External ground connection point
- 5, Side knockout for DC input cable,1-1/4inch
6. Side knockout for AC output cable, 1-1/4inch
7. Side knockout for communication cable › 3/4inch
8. DC fuse holder
9. Internal ground connection point and grounding studs.
10. AC output terminal block

Choose the cables for inverters according to the following configuration table:

Table 2.3 - Cable Specifications

Position	Cable	
DC input (+ / -)	DC cables specifications refer to Table3-6	
AC output (L1/L2/L3/N)	#6~1AWG(Copper) #4~1AWG(Aluminum)	#6AWG recommended(Copper) #4AWG recommended (Aluminum)
PE	#10~6AWG(Copper)	#8AWG recommended (Copper)
RS-485 communication	UTP CAT-5e or 3x#22~18AWG communication cable (eg. Belden 3106A)	

DC GROUND

Even though the inverter operates with an ungrounded PV array, the PV system still requires equipment grounding.

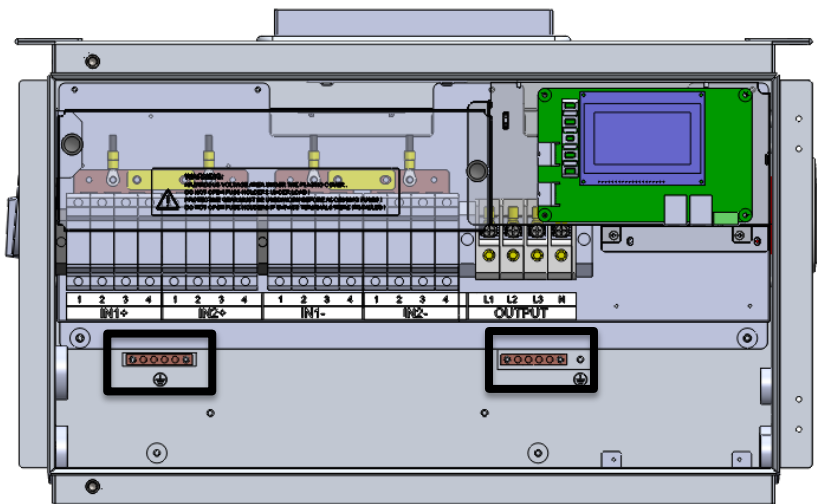

Figure 2.19 - Equipment Grounding Locations

2.3.1 DC Connection

1) Working Mode

PVI 36TL inverter has two PV input sections: DC Input-1 and DC Input-2. These two sections can work in “Parallel mode” or “Independent mode” (see Figure 2.20). The default setting from the factory is “Independent mode”.

In Parallel mode, the two PV input sections share one MPP Tracker; In Independent mode, each PV input section works with independent MPP Tracker.

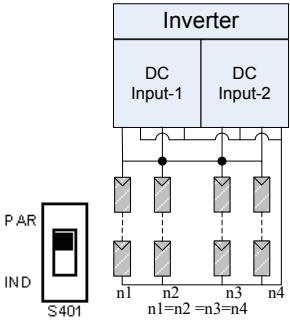

Figure 2.20(a) - Parallel Mode

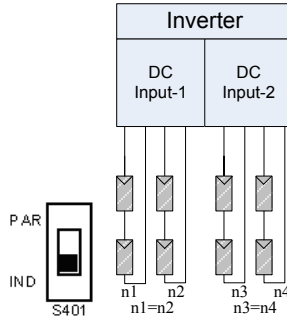

Figure 2.20(b) - Independent Mode

Table 2.4 - DC Input Power Specification

Inverter model	Max. DC input power (Parallel mode)	Rated DC input power of each input section (Independent mode- Default from factory)
PVI 36TL	37kW (70A)	18.5kW (35A)

Note: The standard configuration is “Independent mode”. If it needs to switch to the “Parallel mode”, please take the following steps to change the internal configuration:

1. Remove the cover of the wiring box. (see Figure 2-15)
2. Remove the protection cover. (see Figure 2.21a)
3. Use No.2 Phillips head screwdriver to install the jumper busbar, torque value of 1.6N.m (14 in-lbs) (see Figure 2.21b)
4. Set the selector switch on the LCD board (see Figure 2.22) to parallel mode.
5. Reinstall the protection cover.

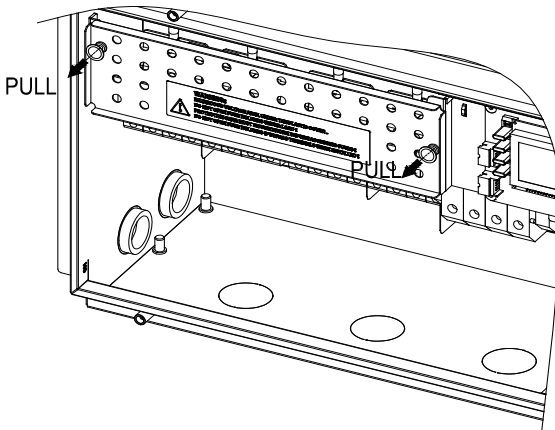

Figure 2.21(a)

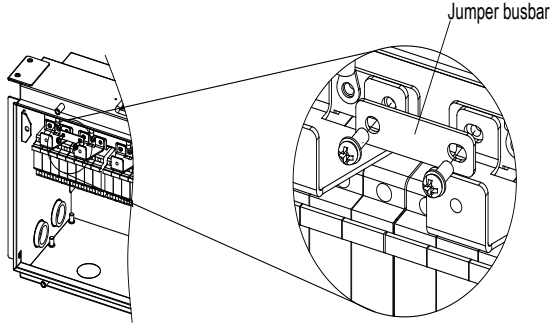

Figure 2.21(b)

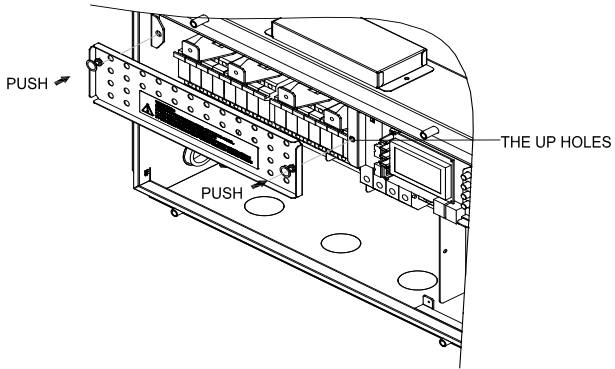
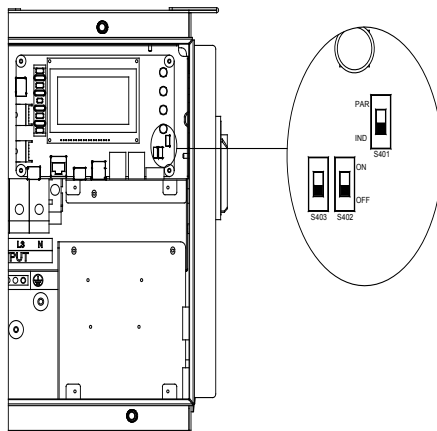

Figure 2.21(c)



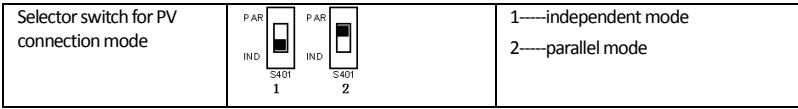

Figure 2.22 – PV Connection Mode Selector Switch Location

2) DC Fuse Configuration

PVI 36TL inverters are equipped with standard 15A DC fuses. Customers must verify that the appropriate fuses are installed depending on the actual configuration of PV strings.

- (a) Each independent string of DC input from the PV strings needs fuse protection.
- (b) The rated voltage of fuses should 1000V
- (c) The rated current of fuses is generally $1.56 \times$ short circuit current from the PV strings, rounded up to the next available fuse size.

The following table lists the fuse type, specifications and number under the rated voltage and power range of 8 strings of PV panels.

36 kW	Brand	Standard fuses	20A	25A	30A
	Littelfuse	SPF015	SPF020	SPF025	SPF030
		15A/1000V	20A/1000V	25A/1000V	30A/1000V

Table 2.5 - DC Fuse Selection

Note 1: The 1000VDC Littelfuse fuse series are recommended. The detailed information is available for customers to find and download from <http://www.littelfuse.com/>.

Note 2: The fuse holders can also accept a 20A (SPF020), 25A (SPF025) and a 30A (SPF030) fuse for combined input strings if needed. Two 30A fuses should not be used next to each other. Note Solectria doesn't provide these fuses, but customer can replace with the appropriate fuse in field.

	<p>WARNING: Use of different fuses or wrong sized fuses can cause damage to equipment or create un-safe working conditions.</p>
---	--

3) DC Cable Connection

To ensure the optimum performance of the inverter, please read the following guidelines before DC connection:

- (a) Confirm the DC configuration referring to Table 2.5 and ensure that the maximum open circuit voltage of the PV modules is lower than 1000 VDC under any conditions.
- (b) Confirm that the PV strings for each MPPT of the inverter are of the same type and specification before connection. The number, orientation, and tilt of PV strings may differ for different applications.
- (c) Configure the external wiring according to the conditions in table 2.6:

	<p>WARNING: Working with live voltage is dangerous. It is recommended to have all live circuits disabled prior to performing connections.</p>
---	--

Table 2.6 - DC Input Configuration

DC Inputs	Configuration	Max. DC Wire Size	Conductors Torque	Fuse Type
10	Using Y** connectors	4 AWG	30 in-lbs	PV Fuse
9*	Using a Y** connector	4 AWG	30 in-lbs	PV Fuse
8	Standard use of wiring box fuses	4 AWG	30 in-lbs	PV Fuse
7*	Standard use of wiring box fuses	4 AWG	30 in-lbs	PV Fuse
6	Standard use of wiring box fuses	4 AWG	30 in-lbs	PV Fuse
5*	Standard use of wiring box fuses	4 AWG	30 in-lbs	PV Fuse
4	Standard use of wiring box fuses	4 AWG	30 in-lbs	PV Fuse
2	Use of Bypass terminals	2 AWG	50 in-lbs	Bypass terminals
1*	Use of Bypass terminal	2 AWG	50 in-lbs	Bypass terminal

- *Consider combining MPPT zones for such configurations
- **Use Inline fuses to adhere to module series fuse rating if necessary

Note: When using Y connectors to combine two strings you have to use a UL listed parts such as: Amphenol Overmolded Solar Junction. When combining 2 strings you should use a Y connector that has a fuse in each branch equal to the module series fuse rating. For 9 inputs you can place the 30A fuse in any fuse holder. For 10 inputs you should place one 30A fuse in each MPPT zone even if they are running in parallel mode. Two 30A fuses should never be next to each other.

- (d) Check the polarity (Figure 2.23) before plugging the DC connectors with the cables of PV strings according to the following steps:
- i. Use a multi-meter to measure the PV strings' cable ends and check the polarity.
 - ii. The positive (+) terminal of cable should match the positive (+) terminal of inverter's DC input.
 - iii. The negative (-) terminal of cable should match the negative (-) terminal of inverter's DC input.



NOTICE:

It is important to use a multi-meter to check the polarity of DC input cables to avoid any risk of reverse polarity.

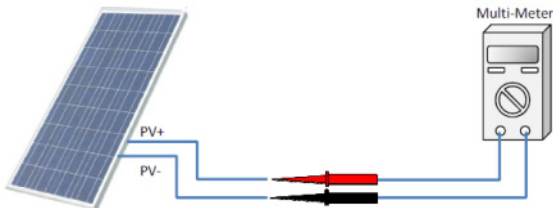

Figure 2.23 - Polarity Check

- (e) Remove the plug from the holes of the DC side and plug the suitable conduits of 1-1/4 inch through the knockouts. Then put the cables through the conduits inside the wiring box.
 - (f) Crimp the DC cables with the attached pre-insulated end ferrule (16Pcs) by using the crimping pliers. (see Figure 2.25)
- Tools: Diagonal pliers, wire stripping pliers, crimping pliers

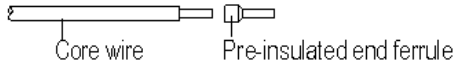

Figure 2.24 - DC Input Cables Set Up

(g) Connect the crimped DC cables to the terminal block on the circuit board and fasten the screws, as shown in Figure 2.25:

Tools: 6mm (0.23in.) flat screwdriver

Torque value: 3.4N-m (30 in-lbs)

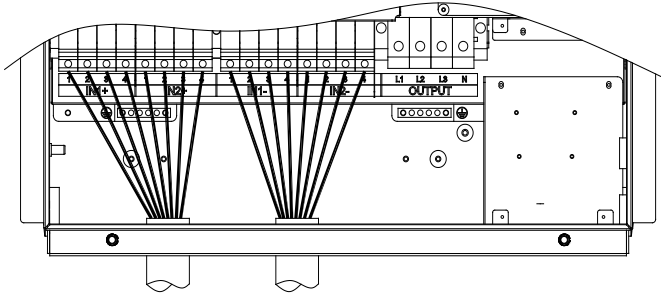

Figure 2.25(a) - DC Input Cable Specifications

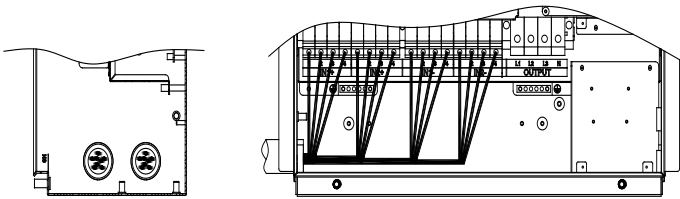

Figure 2.25(b) - DC Input Cable Connections

4) Dual Maximum Power Point Tracking

The inverter is designed with two separate MPP Trackers (Dual MPPT) which can operate independently or combined. The default is independent mode.

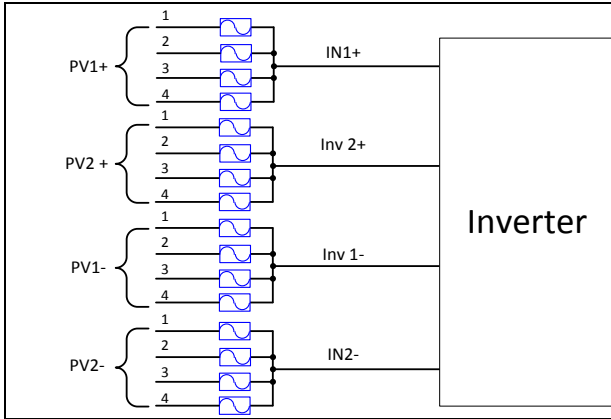

Figure 2.26 - Two MPPTs Operating Independently

Independent mode can be very helpful for sites with shading on parts of the array. **However, this also means that one must consider these two zones as two separate inverters and power must be balanced as much as possible between the two MPPT zones.**



NOTE: Always connect an equal number of wires to PV1 and PV2 connectors for dual MPPT zone operation. If an odd number of connections are required, we recommend setting the inverter to single (combined) MPPT zone.



NOTE: Connecting all of the inputs at zone “PV1” will result in only utilizing 50% of the inverter power



WARNING: Strings must be balanced for optimum performance and AC output. When doing DC/AC ratio sizing, perform calculations on the zone level unless you intend to combine MPPT. Maximum DC/AC oversizing ratio is 1.5 STC conditions of the modules. Each zone maximum input power is 27 kW. Note for any application that may experience higher than 1000 W per m² on a regular basis, a smaller DC/AC ratio is recommended. Failure to follow those guidelines may result in damage to the inverter and may void your warranty.

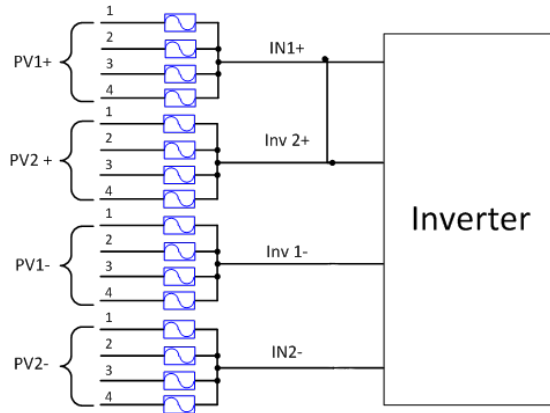

Figure 2.27 - Two MPPTs Combined to Operate as One

When the copper jumpers are installed across DC+ and DC- this allows the power to be evenly distributed between the two trackers such as applications of odd number of strings.

Note 1: The temperature rating of the input wirings should be no less than 90°C (194°F).

Note 2: The recommended fuse types are configured according to the condition that the input strings are the same.

2.3.2 AC and Ground Connection

The following describes how to connect the AC and ground cables between the inverter and the AC grid:

- 1) Use #3 Phillips head screwdriver to loosen the 4 screws on the wiring box and take off the cover. (see Figure 2.-28)
- 2) Remove the plugs from the holes of the AC side and install the suitable conduits of 1-1/4 inch through the holes. Then put the cables through the conduit inside the wiring box.
- 3) The inverter supports 3 kinds of cable connection on the AC side depending on the grounding connection method. The cable set-up procedures are illustrated below.

Use tables 2.-7 and 2.8 for Required tools and Torque values

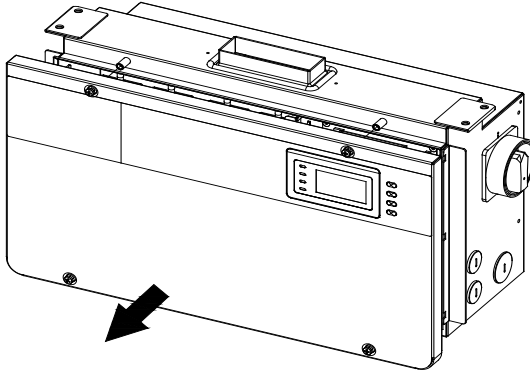

Figure 2.28 - Remove the Wiring Box Cover

Table 2.7 - Required Tools

No.	Tools
1.	#3 Phillips screwdriver
2.	1/4" flat head bit
3.	1/8" flat head bit
4.	Torque driver
5.	Diagonal pliers
6.	Wire stripping pliers
7.	Crimping pliers

Table 2.8 - Torque Values

AC output terminal block	30 in-lbs (3.5 N-m)
Internal grounding bar	14 in-lbs (1.6 N-m)
Internal grounding stud	14 in-lbs (1.6 N-m)
External grounding point	14 in-lbs (1.6 N-m)

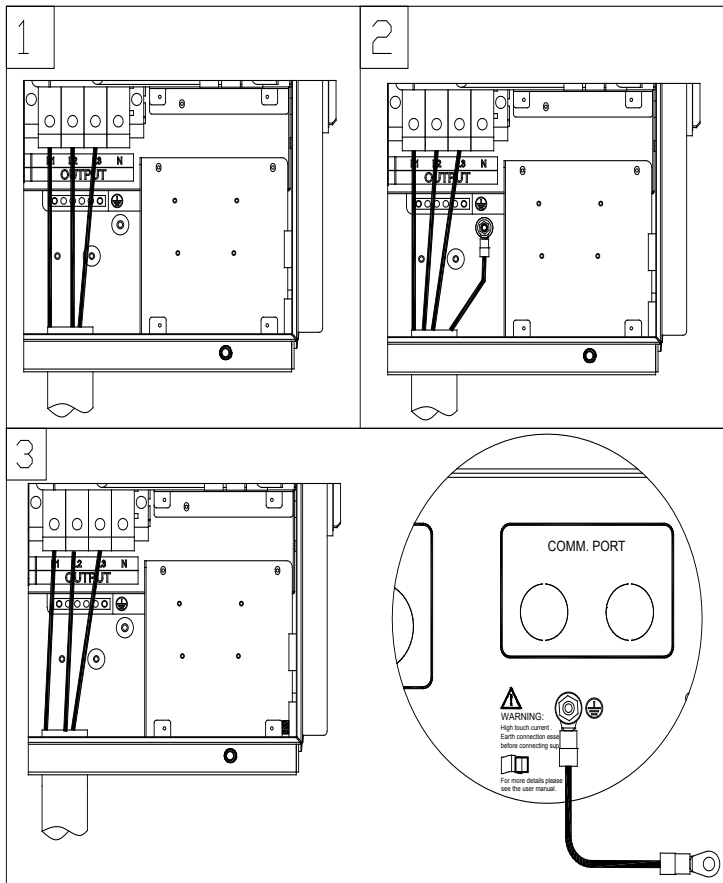

Figure 2.29(a) - AC Output and Ground Cable Connections

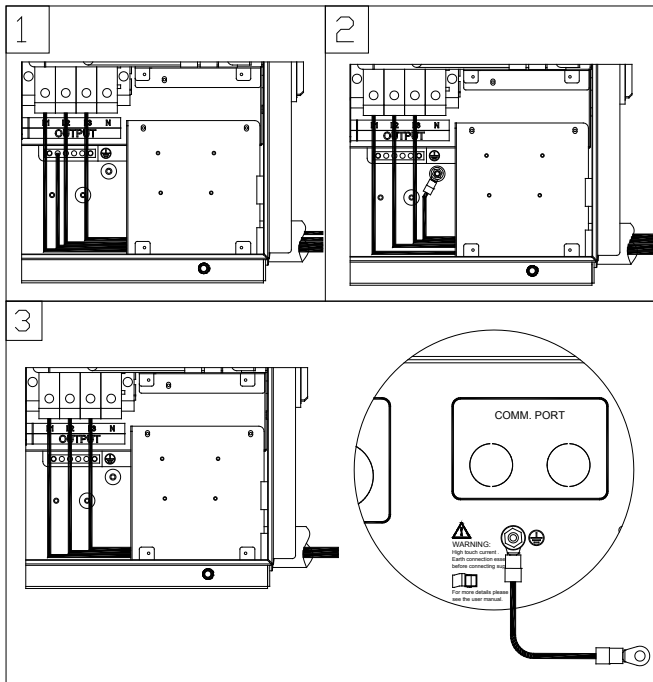

Figure 2.29(b) - AC Output and Ground Cable Connections

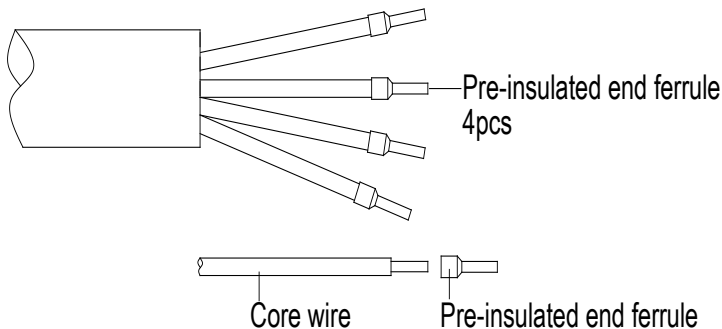

Figure 2.30 - AC Output and Ground Cable Set Up

(1) Connect the AC (L1, L2, L3) cables to the terminal block and use the OT type terminal to connect the ground cable to the internal grounding stud inside the wiring box. (see the 2nd graph in Figure 2.27) Set up the cables referring to Figure 2.29.

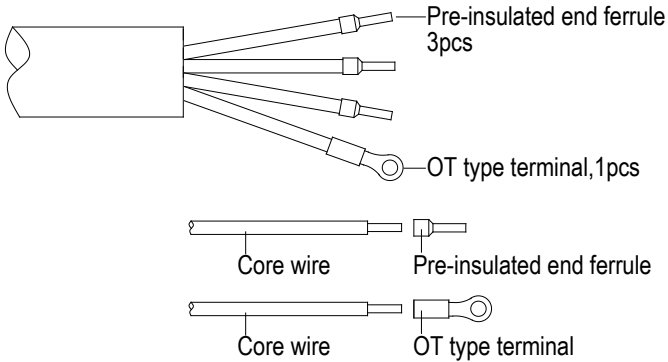

Figure 2.31 - AC Output and Ground Cable Set Up

(2) Connect the AC (L1, L2, L3) cables to the terminal block and use the OT type terminal to connect the ground cable to the external grounding point at the bottom of the wiring box. (see the 3rd graph in Figure 3-27) Set up the cables referring to Figure 2.30.

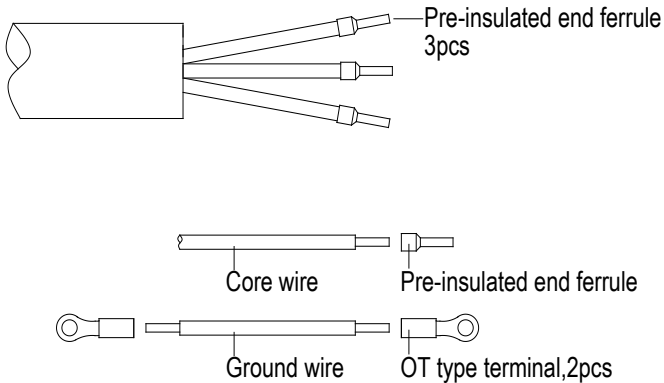

Figure 2.31 - AC Output and Ground Cable Set Up



INSTRUCTION:

The attached pre-insulated end ferrules match with the #6AWG cables. If a different gauge is selected, a different pre-insulated end ferrule will need to be provided by the installers.

4) When the output of the inverter is connected to the grid, an external AC circuit breaker is required to be installed to safely disconnect the inverter from the grid when overcurrent occurs.

5) The Grid connection type could be optional, which can be (L1,L2, L3,N,PE) or(L1,L2, L3,PE) .

Either 3 pole or 4 pole AC circuit breaker should be selected as per the following specifications:

Table 2.9 - AC Breaker Selection

Inverter	AC breaker rated current (A)
PVI 36TL	60

Acceptable Transformer Configurations:

Description	Configuration	Inverter Compatibility
4 Wire WYE (3 phase + Neutral +GND)		Compatible with 36TL
Other Configurations	All other configurations not mentioned in this document, such as Corner Grounded Delta	Not compatible with 36TL

When interfacing with a Wye-grounded transformer winding, a neutral is required. Since the neutral is used by the inverter for voltage sensing, the neutral does not carry full load amps. The size of the neutral may be reduced to a conductor no smaller than the EGC.

When installing multiple inverters for parallel operation connected to a single transformer the KVA rating of the transformer must be at least 5% greater than the total inverter kVA rating that feed the transformer. Up to 70 inverters may be connected in parallel for use with a single transformer.

2.4 Inverter Communication Connections

The PVI 36TL inverters support industry standard Modbus RS-485 communications.

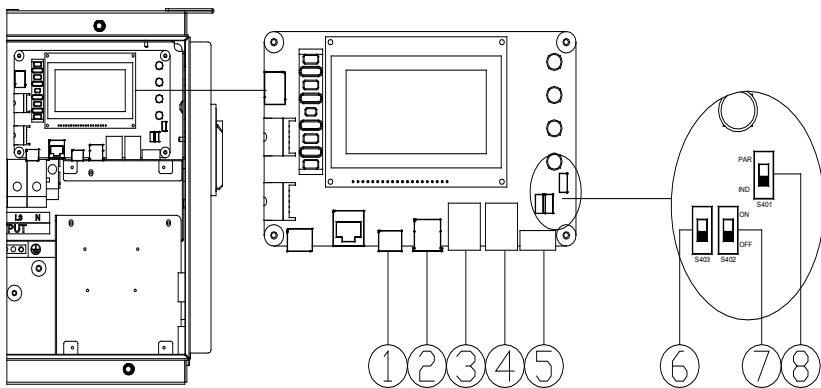

Figure 2.32 - Communication/LCD and Component Locations Inside the Wiring Box

Item	Picture	Configuration description
1	 <p style="text-align: center;">N.O. N.C. COM</p>	<p>P205 - Dry Contact Communication Port (3 Pin Connector)</p> <p>Please see section 2.4.3 Dry contact communication for more details.</p>
2		<p>P207 - USB port</p> <p>Reserved for factory use</p>
3		<p>P204 - Not Used</p>
4		<p>P203 - Not Used</p>
5		<p>P208 - Modbus (RS-485) connector</p> <p>1 - NC</p> <p>2 - NC</p> <p>3 - RS-485+</p> <p>4 - RS-485-</p> <p>5 - NC</p>
6		<p>S403 - Not Used</p>
7	 <p style="text-align: center;">1 2</p>	<p>S402 - Selector switch for the 120Ω Modbus RS-485 termination resistor</p> <p>1 - Disable the RS-485 bus termination</p> <p>2 - Enable the RS-485 bus termination</p>
8	 <p style="text-align: center;">1 2</p>	<p>S401 - Selector switch for setting the PV connection mode</p> <p>1 - Independent mode</p> <p>2 - Parallel mode</p> <p>See section 2.3.1 for more details</p>

Table 2.10 - Communication Connections and Configuration Switches

2.4.1 Modbus (RS-485) Network Connections with External Monitoring Systems

The PVI 36TL inverter can be connected to an external Data Acquisition System (DAS) via Modbus (RS-485) connection as shown in figure 2.33.

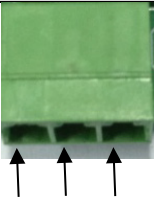
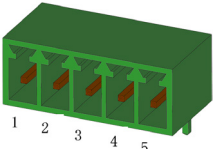
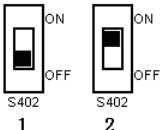
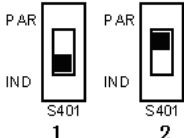
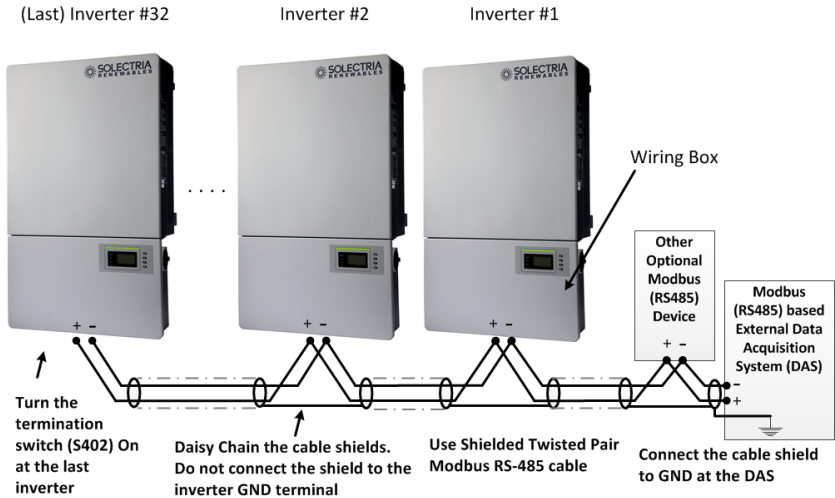

Figure 2.33 - PVI 36TL Inverters in a Modbus (RS-485) Daisy Chain Connected to an External DAS

- When connected to an external Data Acquisition System (DAS), Solectria PVI 36TL inverters support up to 32 inverters/devices on the Modbus (RS-485) daisy chain. The Inverter Modbus IDs are configurable from 1 to 128.
- Solectria recommends that the Modbus (RS-485) daisy chain for PVI 36TL inverters is limited to a maximum length of 1600 ft. (500m).
- Care must be taken when daisy chaining the inverters as shown above, utilizing a Shielded Twisted Pair Modbus cable such as Belden 9841.
- The shield continuity should be maintained for the entire length of the daisy chain and should only be connected to ground (GND) at the Data Acquisition System (DAS). The shield should not be connected to any of the inverters to prevent any possible ground loops.
- It is important to terminate the Modbus (RS-485) bus correctly to minimize any noise and reflections. The bus should be terminated at the source (the DAS) and at the last Modbus device in the daisy chain, typically an inverter. The PVI 36TL Modbus termination is turned on by flipping switch S402 to the ON position as shown in Figure

3-35. S402 should always be left in the off position except for the last inverter in the daisy chain.

- Star or T Modbus (RS-485) network topologies should always be avoided. See Figure 2.34.



(a) Incorrect

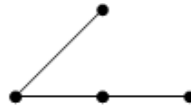

(a) Correct

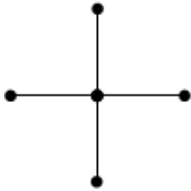

(b) Incorrect

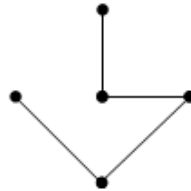

(b) Correct

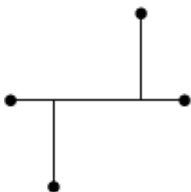

(c) Incorrect



(c) Correct

Figure 2.34

It is important to daisy chain the inverter Modbus (RS-485) connections to minimize noise and bus reflections. Any network topologies shown to the left should be avoided. Equivalent daisy chain topologies shown to the right should be used instead.

Connecting External DAS Modbus (RS-485) Network to the PVI 36TL Inverter:



Warning: Risk of Electric Shock.

Make sure all DC and AC power to the unit has been disconnected before opening the inverter wiring box and make sure hazardous high voltage and energy inside the equipment has been discharged.

1. Open the inverter wiring box.
2. Bring the cable into wiring box through knockout holes at the bottom.
3. Connect the Modbus (RS-485) wires to the green Phoenix connector (P208) ensuring correct polarity and using a twisted pair in the shielded twisted pair cable.
4. If the inverter is the **last** Modbus device in the daisy chain, make sure the Modbus termination switch S402 is in the ON position (Up towards the LCD) enabling Modbus termination. Do **not** turn the switch to the ON position in any other inverters in the daisy chain.

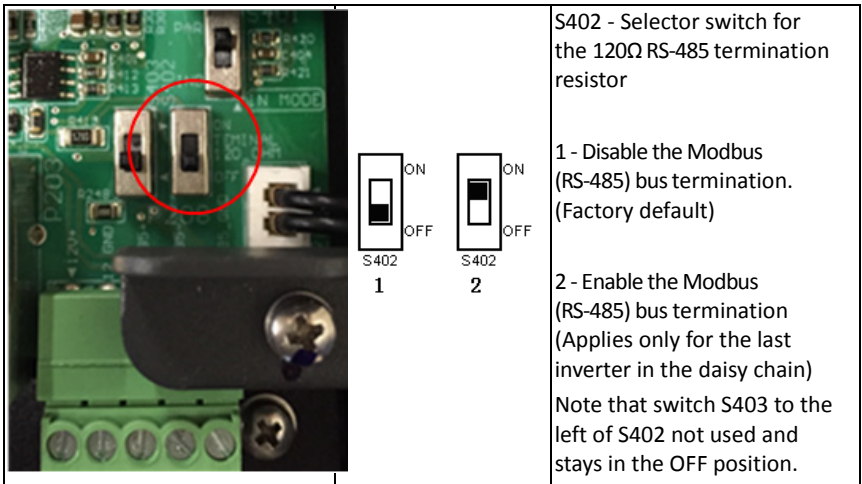

Figure 2.35 - The Modbus (RS485) Termination Switch (S402) Location and Settings on the LCD/Communication Board.

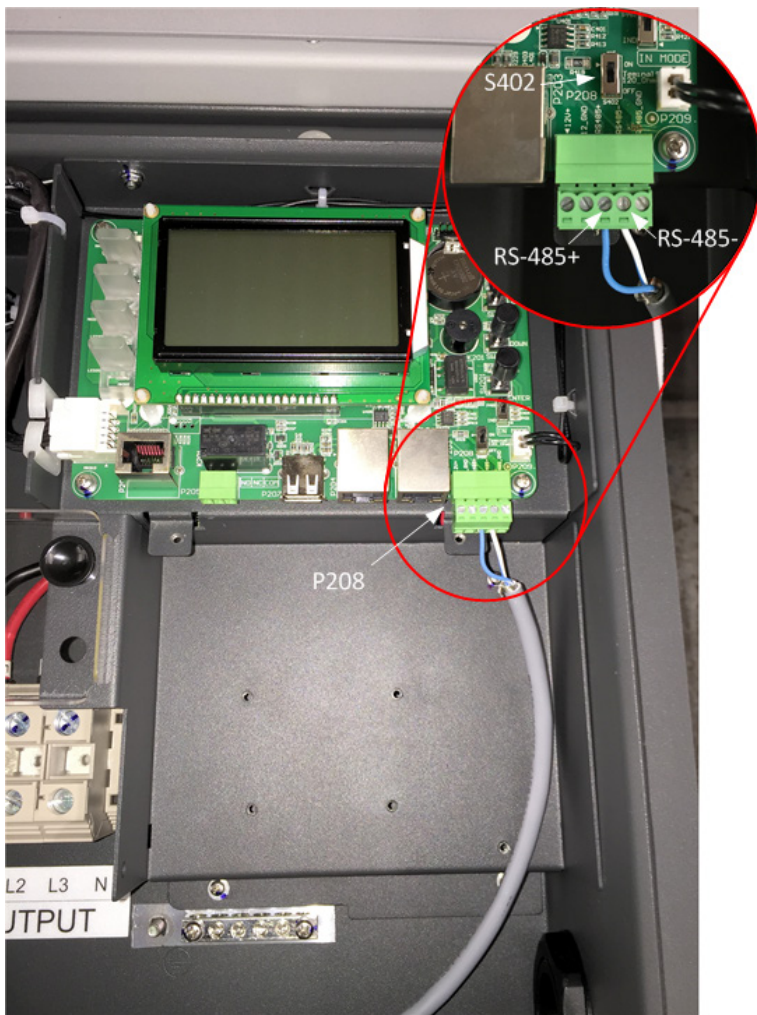

Figure 2.36

The above image shows the Modbus (RS-485) cable connection where the Modbus daisy chain ends. Notice how the cable shield is not landed inside the inverter. The Modbus termination switch (S402) is in the on position.

5. **IMPORTANT:** The cable shield should only be connected to ground (GND) at the external DAS. Do not connect the shield to any of the inverters

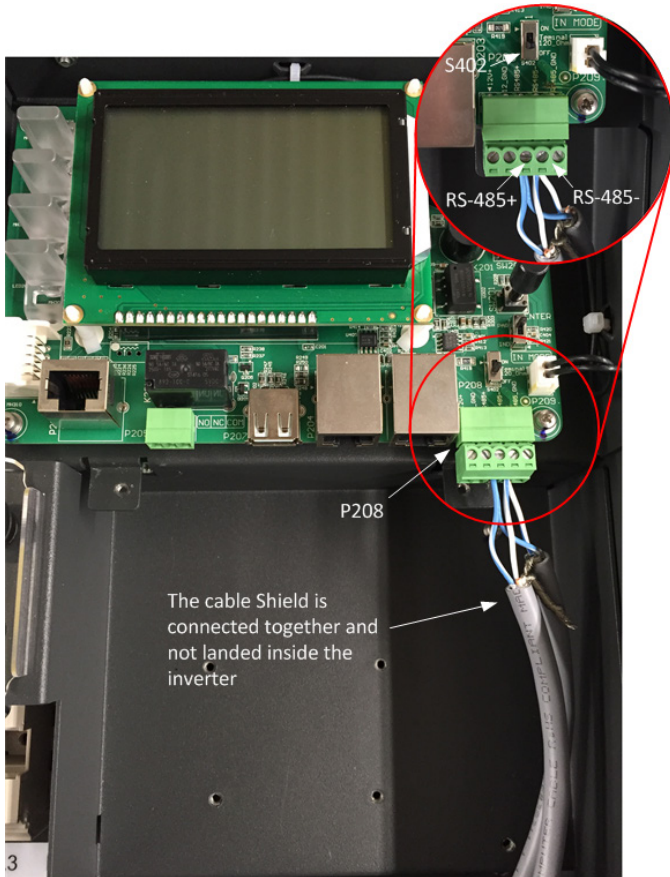

Figure 2.37

Notice how the cable shield is daisy chained together and not landed inside the inverter. S402 is in the OFF position, or down towards the Phoenix connector when the inverter is in the middle of the daisy chain.



Warning: Risk of Electric Shock.

Make sure all shield wires are properly secured and insulated to prevent shorting to any other components inside the inverter.

6. Close the wiring box.
7. Reconnect AC and DC power and turn the inverter on when it is safe.
8. Configure the Inverter Modbus ID and Baud rate.

2.4.2 Modbus (RS-485) Network Connections with SolrenView Data Logger

If the PVI 36TL inverters are ordered with SolrenView data monitoring services from the factory, the SolrenView data logger is installed in the factory in one of the inverters. This inverter should be installed as Inverter number 1 in the Modbus daisy chain as shown in Figure 2.38.

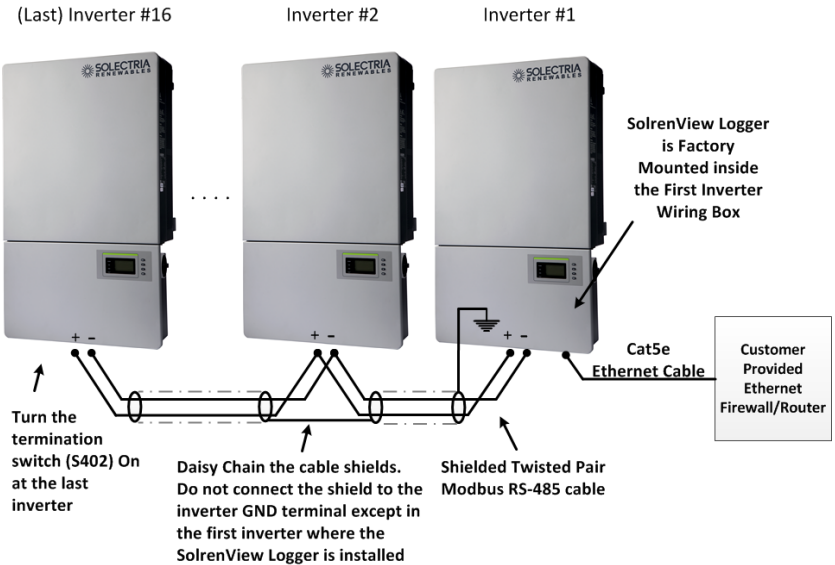

Figure 2.38 - Typical PVI 36TL Network Connections Utilizing SolrenView Data Logger

For information how to install the SolrenView data logger inside the PVI 36TL inverter see the *"SolrenView Installation Guide for PVI 14-36TL Inverters"* (DOCR-070580-A) document available on the Solectria document website.

Connecting the Ethernet Router/Firewall to the SolrenView Data Logger:

The SolrenView Data logger is connected to the customer provided Ethernet router/firewall utilizing a Cat 5e or better Ethernet cable as shown in figure 2.38.

The Ethernet cable length must be kept shorter than 328ft (100m) to ensure trouble free communications.

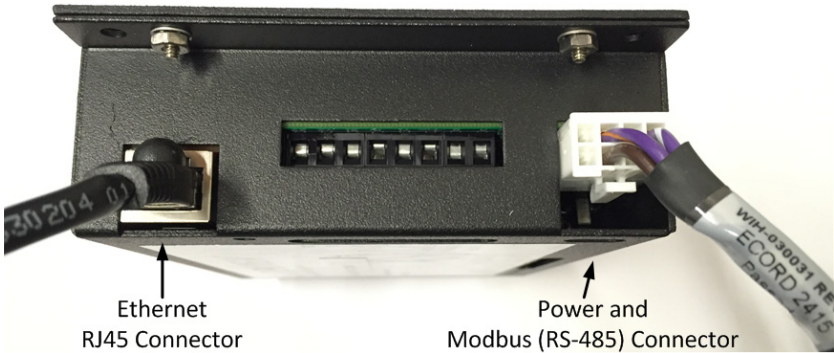

Figure 2.39. - SolrenView Data Logger Connections.

Connect the Ethernet cable to the RJ45 port on the SolrenView data logger before mounting it inside the wiring box.

Router/Firewall Configuration:

The router/firewall should not require any special configuration as most routers are already configured to support DHCP discovery and to allow outgoing traffic. In case the router/firewall is configured to restrict outgoing traffic, an outgoing rule must be added to allow the logger to connect to the SolrenView Monitoring data servers.

Connecting the Modbus (RS-485) Network to the PVI 36TL Inverters with SolrenView Data Logger:



Warning: Risk of Electric Shock.

Make sure all DC and AC power to the unit has been disconnected before opening the inverter wiring box and make sure hazardous high voltage and energy inside the equipment has been discharged.

- The SolrenView data logger acts as the Modbus Master and can support up to 16 inverters on the Modbus (RS-485) daisy chain utilizing Modbus IDs 1 through 16. If more than 16 inverters are required, additional SolrenView data loggers must be added, with each logger supporting up to 16 inverters per daisy chain.
 - Solectria recommends that the Modbus (RS-485) daisy chain for PVI 36TL inverters is limited to a maximum of 1600 ft. (500m).
 - The inverter Modbus (RS-485) connections must utilize a Shielded Twisted Pair Modbus cable such as Belden 9841.
 - The cable shield continuity should be maintained for the entire length of the daisy chain and should only be connected to Chassis GND inside the first inverter containing the SolrenView data logger. The shield should not be connected to any of the other inverters to prevent any possible ground loops.
 - Star or T Modbus (RS-485) network topologies should be avoided. See Figure 2.34.
 - It is important to terminate the Modbus (RS-485) bus correctly to minimize any bus noise and reflections. The bus should be terminated at the SolrenView data logger and at the last Modbus device in the daisy chain, typically an inverter. The PVI 36TL Modbus termination is turned on by flipping switch S402 to the ON position as shown in Figure 2.35. S402 should always be left in the off position except for the last inverter in the daisy chain.
1. Open the inverter wiring box.
 2. Bring the Modbus cable into the wiring box through knockout holes at the bottom.
 3. If the inverter is the **last** device in the daisy chain, make sure the Modbus termination switch S402 is in the ON position (Up towards the LCD) for Modbus termination. **Do not** turn the switch to the ON position in any of the other inverters. See Figure 2.35.
 4. The SolrenView data logger is shipped from the factory with the Modbus termination turned ON. The two Modbus termination dip switches closest to the white Molex connector (#3 and #4 on SW1) should be in the ON position towards the edge of the board. (See Figure 2.40)

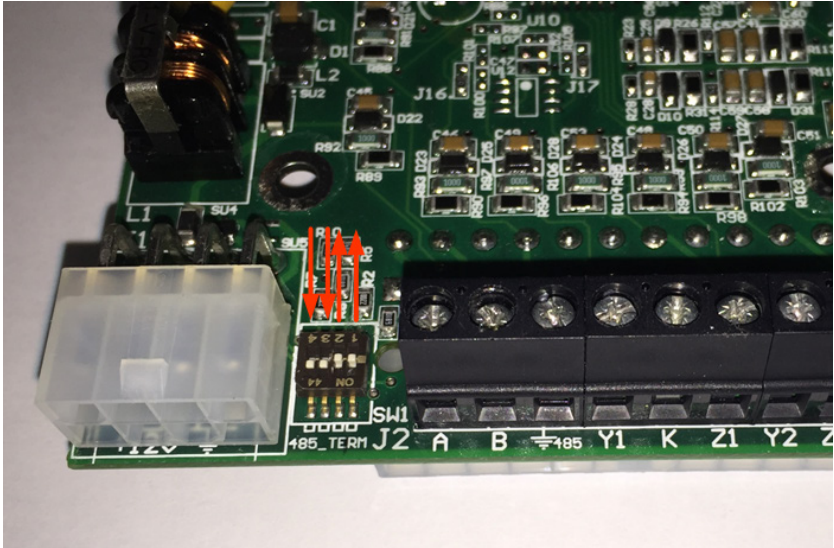

Figure 2.40 - The SolrenView Data Logger Printed Circuit Board and the Modbus Termination Dip Switches.

5. Extend the Modbus cable shield with additional wire so that it can reach to the Chassis GND terminal block as shown in Figure 2.41. The wire should be soldered to the cable shield to ensure solid and reliable connection. The shield connection should be covered with a heat shrink tubing to prevent any shorts to other components inside the inverter. The wire should be kept as short as possible to minimize any noise pickup.
6. Connect the external Modbus (RS-485) cable to the green Phoenix connector (P208), ensuring correct polarity and using a matching twisted pair in the Modbus cable. See Figure 2.41. Care must be taken not to disconnect the Modbus wires coming from the SolrenView logger.

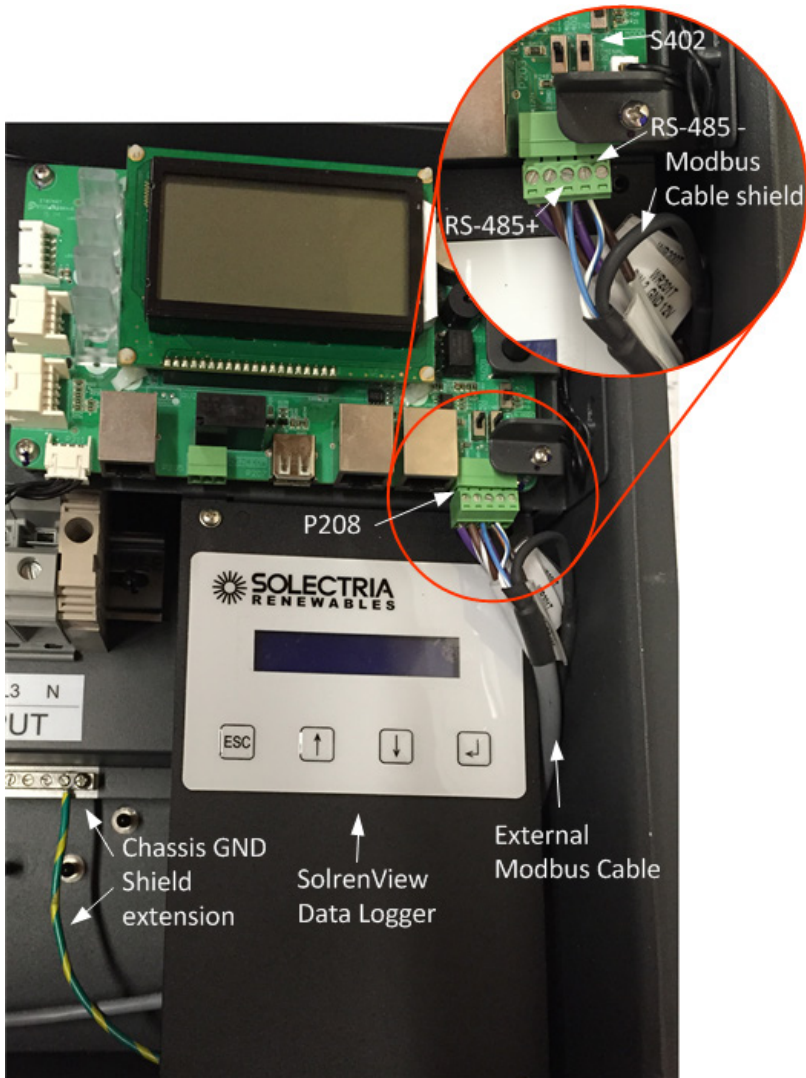

Figure 2.41 - SolrenView Data Logger Installed Inside the PVI 36TL Wiring Box.

Notice how the Modbus cable shield is grounded by extending the Modbus cable shield with a wire and connecting it to the inverter chassis GND terminal.

The external Modbus cable is connected to P208 sharing the +/- RS-485 connections with the SolrenView data logger.

7. Follow steps 5 through 8 in section 2.4.1 Modbus (RS-485) Network Connections with External Monitoring Systems to connect other inverters in the daisy chain.



Warning: Risk of Electric Shock.

Make sure all shield wires are properly secured and insulated to prevent shorting to any other components inside the inverter.

Configuring the SolrenView Logger:

The SolrenView logger should be connected to an active router/firewall and inverters before the inverter containing the SolrenView logger is turned on. The SolrenView Logger will go through self-initialization, TCP/IP DHCP discovery and inverter Modbus device discovery when it turns on.

To verify that the SolrenView logger has discovered all the inverters in the daisy chain, navigate the SolrenView data logger menu to the “Inverters” menu item by pressing the ENTER key. All the discovered inverters should be listed by Modbus ID and serial numbers on the LCD.

2.4.3. Dry Contact Communication

The inverter features an alarm function that opens or closes a dry contact on the communication board. (available both as contact normally open – N.O. – and as contact normally closed – N.C.), as shown below:

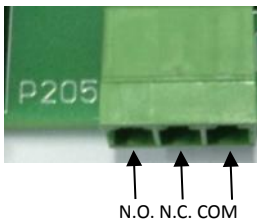

Figure 2.34 - Dry Contact Communication Port

The voltage and current rating of the dry contact shown in the following table must not be exceeded under any circumstances.

Table 2.11 - Dry Contact Rating

	Voltage	Current
AC	Maximum 277 V	Maximum 3 A
DC	Maximum 30 V	Maximum 1 A

Different modes of dry contact output can be accessed by connecting different pins of the P205 connector, as shown in following table.

Table 2.12 - Working Modes of Dry Contact

Dry contact communication port	Status in fault condition	Status without fault condition
P205: N.O. — COM	Closed	Open
P205: N.C. — COM	Open	Closed

Connection Plan:

You can connect a LED or other loads to indicate the operational status of the inverter, as shown in the following figure:

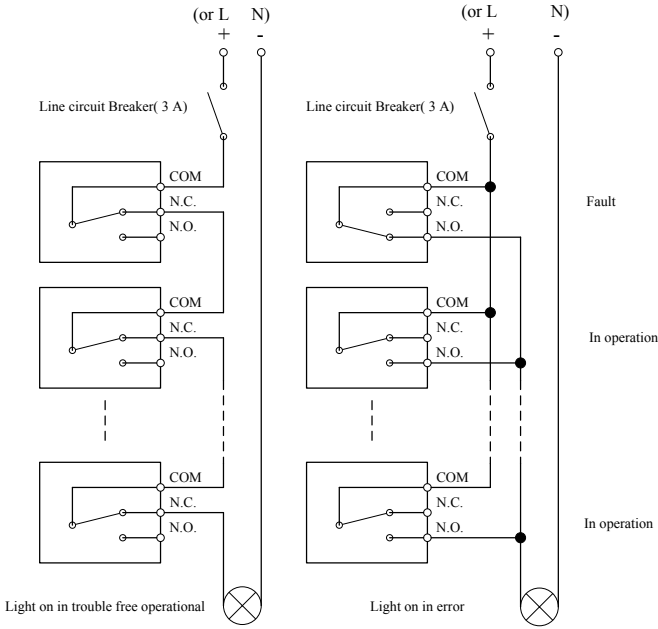

Figure 2.35 - Dry Contact Communication Schematic Diagram

If you connect the contact port to the power distribution grid, you must install an individual miniature circuit-breaker between the dry contact and the power distribution grid.

Dry Contact Communication Cable Connection:

Warning: If the unit is running, turn off both disconnects and wait 5 minutes before performing any work.

- a.) Remove the plugs from holes for suitable cable conduits of 3/4 inch.
- b.) Put the dry contact communication cable through the cable conduit and inside the wiring box.
- c.) Use double-layer insulated cables. Strip the cables according to the following requirements.

Tool: Wire stripping pliers

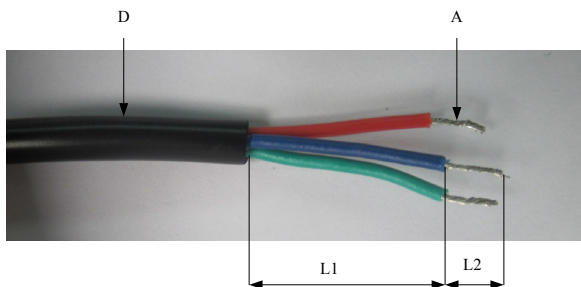

Figure 2.36 - Wire Stripping

Table 2.13 Cable Set-Up

Position	Description	Value
	Cable type	Double-layer insulated cable
D	Outer diameter	4.5 mm~ 6 mm
A	Cross-section area of conductor	0.2 mm ² ~ 0.75 mm ²
L1	Length of stripped outer wire skin	Maximum 15mm
L2	Length of stripped inner wire skin	Maximum 7 mm

d.) Connect wires to the terminal.

Tool: 2 or 2.5mm flat screwdriver



No.	Cable Color	Function
1	Red	N.O.
2	Blue	N.C.
3	Green	COM

Figure 3-37 - Wire Connection

e.) Plug the cable terminal into the P205 connector.

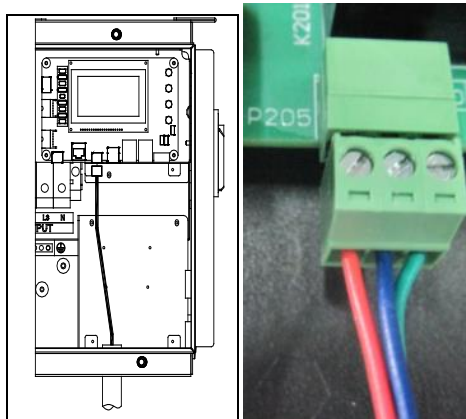

Figure 2.38 - Dry Contact Communication Cable Connection

3.0: Commissioning



WARNING:

Please follow the guidelines below before on-grid operation to eliminate possible dangers and to ensure safety.

3.1 Commissioning Checklist

3.1.1 Mechanical Installation

Make sure that the mounting bracket is secure and all the screws have been tightened to the specified torque values.

(Please refer to 2.2 Mechanical Installation)

3.1.2 Cable Connections

- (a) Make sure that all cables are connected to the right terminals.
- (b) The appropriate cable management is important to avoid physical damage.
- (c) The polarity of DC input cables should be correct and the DC Switch should be in "OFF" position.

(Please refer to 2.3 Electrical Installation)

3.1.3 Electrical Check

- (a) Make sure that the AC circuit breaker is appropriately sized.
- (b) Test whether the AC voltage is within the normal operating range.
- (c) Make sure the DC open circuit voltage of input strings is less than 1000V.

3.2 Commissioning Steps

Complete the checklist above before commissioning the inverter as follows:

- 1.) Turn on the AC circuit breaker.
- 2.) Turn on the DC circuit breaker.

(Skip this step if there is no circuit breaker.)

- 3.) Switch the DC Switch to the "ON" position. When the energy supplied by the PV array is sufficient, the LCD of inverter will light up. The inverter will then start up with the message "sys checking".
- 4.) Set up the grid standard:



INSTRUCTION:

Please check with your local electricity provider before selecting the grid standard. If the inverter is operated with a wrong grid standard, the electricity provider may cancel interconnection agreement.

Putting the inverter into operation before the overall system complies with the national rules and safety regulation of the application is not permitted.

- (d) When the inverter completes “*sys checking*”, the LCD shows the screen as Figure 3.1 below. Press ENTER to the standard selection interface, as shown in Figure 3.2.
- (e) Select the corresponding grid standard and press ENTER.

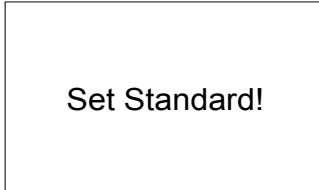

Figure 3.1 - Set Up Grid Standard

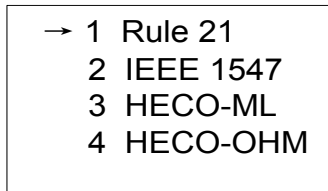
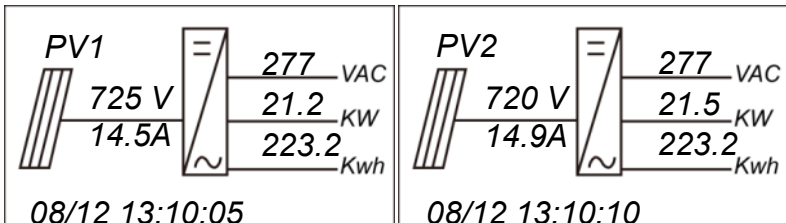

Figure 3.2 - Select Grid Standard

5.) When the LCD shows the normal operation status (Figure 3.3) and the “RUN” light on the LED panel lights up, it indicates that the grid connection and power generation are successful.



(a) (b)
Figure 3.3 - Normal Operation Status

- 6.) If the inverter fails to operate normally, the “FAULT” LED will illuminate and the error message will be displayed on the LCD.
(Please refer to 7.1.2 Troubleshoot LCD faults)
- 7.) Set up system time and language
Set up the system time and language according to “4.4.4 System Configuration”.
- 8.) To check the real time operation information, you can refer to “4.4.1 Operation information”.

4.0: User Interface

4.1 Description of LCD

The inverter’s LCD mainly consists of LCD, LED indicator lights, buzzer and 4 keys, as shown in Figure 4.1.

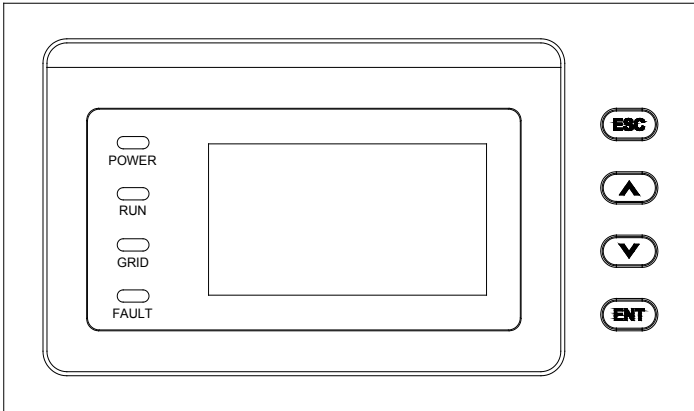

Figure 4.1 - LCD





Interpretation for the indicator lights is shown in Table 5-1 and function of the keys is shown in Table 4.2.

Table 4.1 - LED Indication

LED Indicator	Name	Status	Indication
POWER	Working power light	Light on	Energized (control panel starts to work)
		Light off	Power supply not working
RUN	Grid-tied operation indication light	Light on	In grid-tied power generation state
		Flash	Derated running status (light on 0.5s, light off 1.6s)
		Light off	In other operation status or power supply not working
GRID	Grid status indication	Light on	Grid is normal
		Flash	Grid fault (light on 0.5s, light off 1.6s)

	light	Light off	Power supply not working
FAULT	Fault status indication light	Light on	Indicates a Fault
		Slow flash	Indicates Alarm (light on 0.5s, light off 2s)
		Fast flash	Protective action (light on 0.5s, light off 0.5s)
		Light off	No fault or power supply not working

Table 4.2 - Definition of the Keys

Key	Description	Definition of function
	Escape key	Back/end/mute
	Enter key	Confirm entering the menu/confirm set value/Switch to parameter setting mode
	Up	Page up in selection menu/+1 when setting parameters
	Down	Page down in selection menu/-1 when setting parameters

4.2 Operation State

Table 4.1 indicates the definitions of LED, i.e. indicates the information of the inverter's operation state. It indicates that the system is energized and under DSP control when "POWER" lights up.

"RUN" will light up when the inverter detects that the grid connection conditions meet the requirements and power is fed into the grid. "RUN" will blink if the grid is in de-rated running state during the period of feeding power into the grid.

"GRID" will light up when the grid is normal during the operation of the inverter. Otherwise, "GRID" will blink until the grid restores to normal.

"FAULT" will blink quickly as a fault (except grid fault) occurs. "FAULT" will not turn off until the fault is eliminated. The light will blink slowly when an alarm occurs. "FAULT" remains illuminated when an internal fault occurs.

The buzzer will give an alarm if a fault (involving power grid fault) occurs.

4.3 Interface Types

Users can perform the corresponding operations with the 4 function keys

according to the indications of the LCD.

(1) The LCD interface starts with the company logo once the system is energized, as shown in Figure 4.2.



Figure 4.2 - Logo Screen

(2) Indication of inverter operation mode:

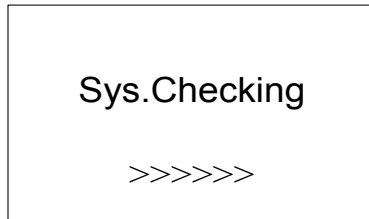

Figure 4.3 - Inverter System Check Ongoing

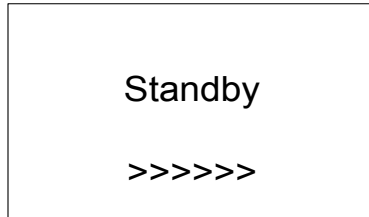

Figure 4.4 - Inverter System in Standby Mode

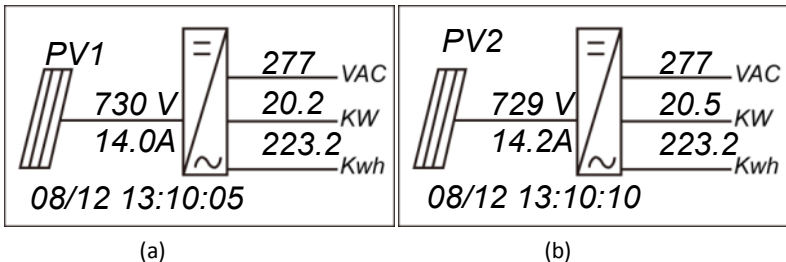

Figure 4.5 - Default Display Interface for Normal Operation



Figure 4.6 - Fault Indication Interface

LCD will display different mode interfaces based on the operation modes of the inverter. There are four operation modes: **startup** system check mode (as shown in Figure 4.3), **stand-by** mode (as shown in Figure 4.4), **normal operation** mode (as shown in Figure 4.5, the switching time between (a) and (b) is 5 seconds), and **fault** mode (as shown in Figure 4.6).

The default indication interface mainly indicates PV voltage, PV current, grid voltage, instant power, daily generated power and time information under normal operation.

The fault information of the most recent / current fault will be indicated on the LCD when the inverter is in fault mode.

4.4 Menu functions

LCD displays “default indication interface” when the inverter is in operation mode. Press **ESC** in this interface to escape the default interface and enter the main operation interface. The main operation interface is shown in Figure 4.7.

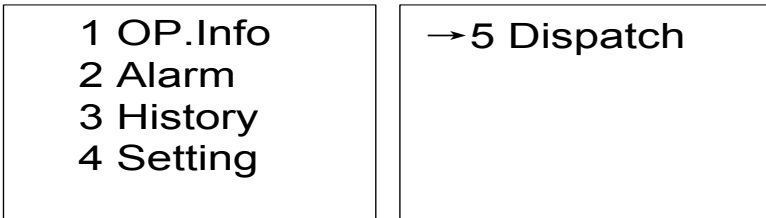

Figure 4.7 - Main Menus on the LCD

The users may select options with **UP** and **DOWN**, and then press **ENT** to confirm selection. The users can return to the default indication interface by pressing **ESC**.

4.4.1 Operation information

When the cursor moves to “1 OP. Info” in the main screen, you should press **ENT** to select the operation information as shown in Figure 4.8. Check the information by pressing **UP** and **DOWN**. Return to the previous menu by pressing **ESC**.

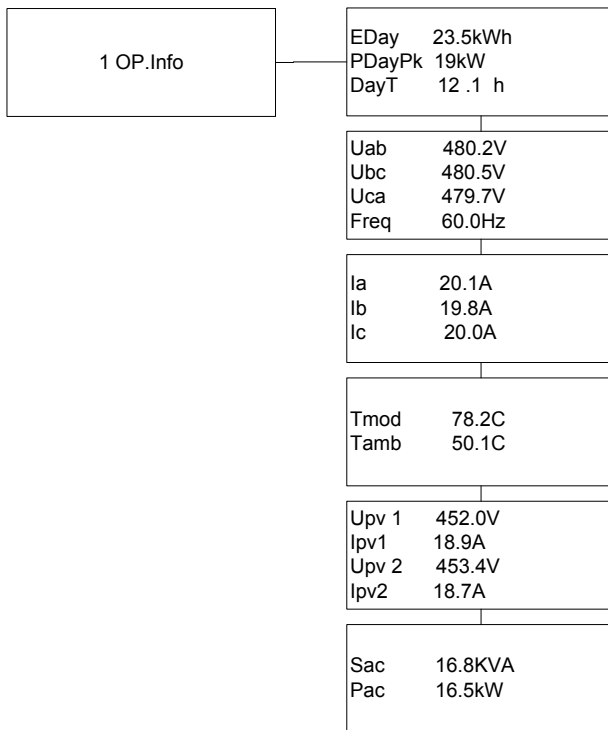

Figure 4.8 - Operation information indication (PV independent mode)

Remarks : The LCD is shown with PV parallel mode selected.

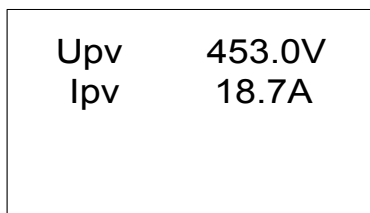

Figure 4.9 - Operation Information Indication (PV Parallel Mode)

4.4.2 Alarm

As previously noted, if a fault occurs during normal operation of the inverter, corresponding fault messages will be indicated in "2 Alarm" menu in addition to the sound and light alarms. Move the cursor to "2 Alarm" and press **ENT** to check out the specific fault information, as shown in Figure 4.10.

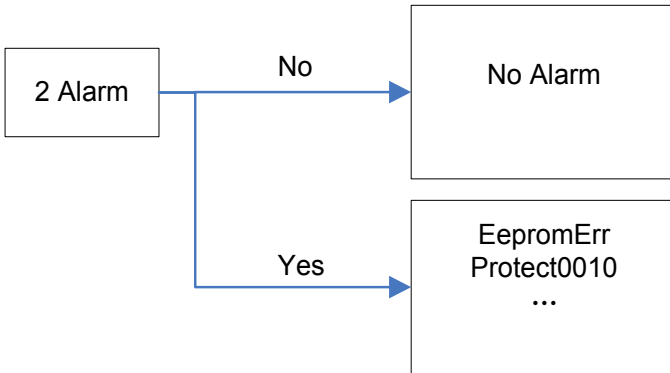

Figure 4.10 - Alarm / Failure Information

4.4.3 History

Move the cursor to “3 History” in the main interface. Press **ENT** to check the history information, as shown in Figure 4.11. There are 4 submenus in “3 History”: “1 HistErr”, “2 OP. Recd”, “3 Version” and “4 TotalTag”.

(1) The error log can store up 100 fault messages in “1 HistErr” menu.

(2) The last 21 days of operation history data is available to be checked in “2 OP. Recd” menu. All variable names in the data comply with the content in “1 OP. Info” menu of the main interface. The users can select the “2 OP. Recd” menu and review the last 21 days of operation.

(3) The DSP version, LCD version and serial number of the product are listed in “3 Version” menu.

(4) Cumulative generated power from the first day the inverter began working is available to be checked in “4 TotalTag” menu.

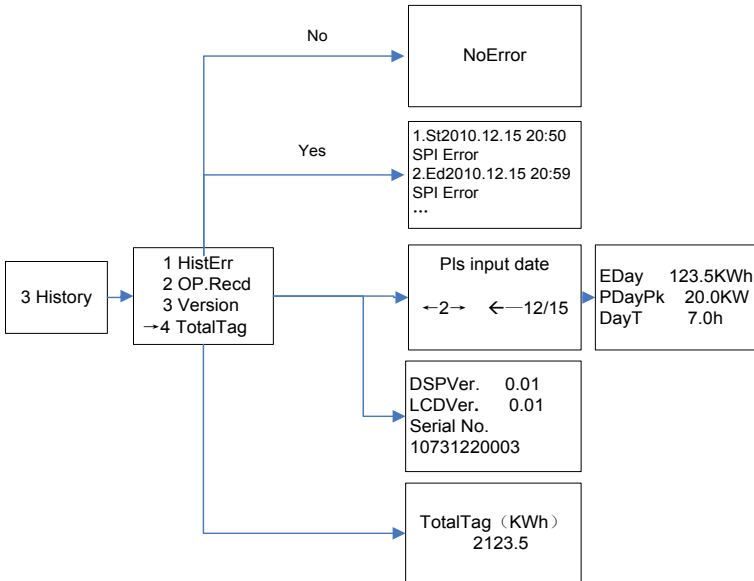

Figure 4.11 - History Menu and Submenu

4.4.4 System Configuration

Move the cursor to “4 Setting” in the main interface. Press **ENT** to enter the password: **UP** -> **DOWN** -> **UP** -> **DOWN**. Press **ENT** to confirm, and set the current system parameters, as shown in Figure 5-12. There are 7 submenus in “4 Setting”: “1 ON/OFF”, “2 Language”, “3 Buzzer”, “4 SysTime”, “5 Commun.”, “6 OtherCmd” and “7 NetConfig”.

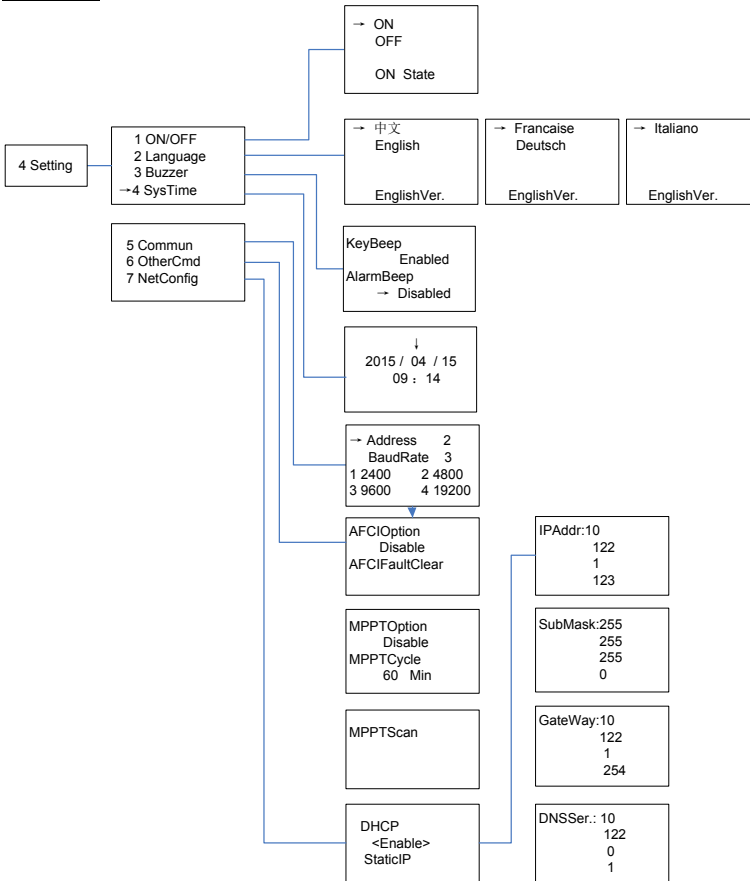

Figure 4.12 - System Setup Menu and Submenu

(1) The inverter can be started and shut down with “1 ON/OFF” menu. Move the cursor to “ON” and press **ENT**, “ON State” will then be indicated at the bottom of LCD; move the cursor to “OFF” and press **ENT**, then “OFF State” will be indicated as well.

The inverter will stand by instead of working normally if the startup conditions do not meet the needed values even if "ON" is selected. The inverter will shut down immediately if "OFF" is selected in any case.

(2) Five languages, i.e. English, French, Chinese, German, and Italian are available in "2 Language" menu.

(3) Key beep and Alarm beep can be set mute/unmute in "3 Buzzer" menu. "Key beep" and "Alarm beep" can be chosen by pressing **UP** and **DOWN**. Shift between "Enable" and "Disable" by pressing **UP** and **DOWN** if the cursor is on the "Key beep". Complete the setup by pressing **ENT**. Similarly, the Alarm beep can be set up in the same way.

(4) Set up the system date and time with "4 SysTime" menu (These parameters are of critical importance and will be used in history information).

(5) Set the 485 communication parameters with "5 Commun." menu.

(6) There are 5 submenus in the "6 other Cmd" menu:

1. Arcing check and protection is mainly divided into two parts, the Arcing check board is responsible for whether there is Arcing in line, and transfer Arcing protection signal to the DSP in the control board. The control board (DSP) is responsible for the control of inverter off the grid after receiving Arcing signal to ensure safety. The Arcing board failure will cause 'arc board err' shown on the LCD and it will not connect to the grid until the arc board is OK. If there is Arc-fault, the LCDs the fault which can only be cleared manually.

"ARCOption" is used to enable/disable the ARC function. Press **ENT** and use **UP** and **DOWN** to enable/disable the ARC function, and press **ENT** to confirm the setting.

2. "ARCFaultClear" is used to clear the Arc-fault. Move the cursor to this menu, and press **ENT**. The operation result will appear on the LCD, i.e. "Succeed" or "Failed".

3. MPPT scan function is effective if :

1) In parallel mode, the total input power is lower than 90% of the active power in parallel mode.

2) In Independent mode, each input power is lower than 75% of the rating power of each MPPT tracker.

Once this MPPT scan function is set on LCD, it will search the maximum power point at a voltage step of 5V in the MPPT range for full load, and get the maximum power point.

"MPPTOption" is used to enable the MPPT Scan. Move the cursor to this item, press **ENT** to set up the function. Use **UP** and **DOWN** to enable/disable the "MPPTOption" function. Press **ENT** to confirm the setting.

4. "MPPTCycle" is used to set up the cycle time of MPPT Scan. Move the cursor to this item, press **ENT** to set up the cycle time. Use **UP** and **DOWN** to adjust the MPPT cycle time. Press **ENT** to confirm the setting.

5. "MPPTScan" is to execute the MPPT scanning manually. Move the cursor to this item, and press **ENT** to initiate the scanning. The LCD will skip to normal operation

interface if the MPPT scanning succeeds, or remain on the “MPPTScan menu” interface if the scanning fails.

(7) Configure the network address in the “7 NetConfig” menu.

Move the cursor to the menu, press ENT and set up the parameters by **UP** and **DOWN**. Note if you have a daisy chain you cannot have two devices (inverters or other Modbus devices) with the same network ID.



INSTRUCTION:

Move the cursor to the corresponding menu to set up the parameters, and the number will flash after pressing ENT. Use **UP** and **DOWN** to adjust the parameters.

4.4.5 Power dispatch

Move the cursor to “5 Dispatch” in the main interface and press **ENT** to go to the following interface (Figure 4.13):

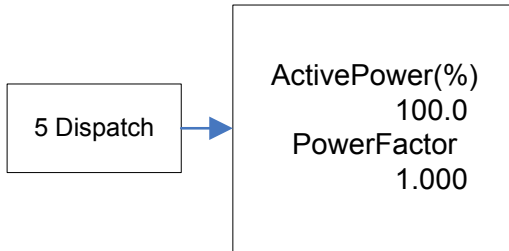

Figure 4.13 Active Power and PowerFactor

Remote power dispatch: The “ActivePower” and “PowerFactor” can be adjusted remotely by software.

4.4.6 System Protection Parameters Setup

Press **DOWN** and **ENT** at the same time in the main interface and enter the password (UP -> DOWN -> UP -> DOWN) to access the system protection parameters setup menu. This menu includes 6 submenus: “1 SysPara”, “2 Restart”, “3 Recover”, “4 ClrErrRecd” and “5 Stdset”, as shown in Figure 4.14.

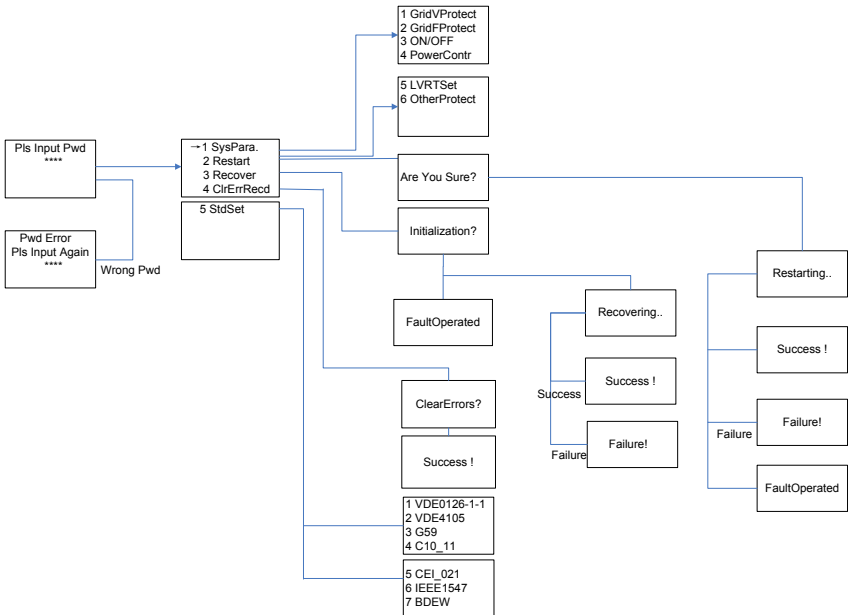

Figure 4.14 - System Protection Parameter Configuration

- (1) The system protection parameters of each grid standard can be set up in “1 SysPara” menu. Please refer to Section 4.4.7.
- (2) “2 Restart” menu: If a fault shutdown arises, a severe fault may have occurred inside the inverter. The user can perform a force reboot for one time in this menu if the user needs to restart the inverter.



INSTRUCTION:

This function is effective only when the fault “IntFault0010~0150” in the troubleshooting table occurs. The inverter may restore to normal operation automatically if alarm or protection faults occur. This function will not respond when the inverter is in operation mode and a “FaultOperated” alarm interface will be indicated.

- (3) “3 Recover” menu: The manufacturer’s parameter default value can be restored when the inverter is not in operation mode. Otherwise “Fault Operated” will be reminded.
- (4) “4 ClrErrRecd” menu: History information of the failures can be wiped clear after confirmation
- (5) “5 Stdset” menu: The grid standard can only be changed when the inverter is turned off by LCD shut down. The change is ineffective under normal operation mode. Please refer

to “5.2 Shut down” after the inverter stops working, and choose the grid standard as per the local requirement of the electricity supply company.

**NOTICE:**

Please don't change the grid standard when the inverter is in normal operation mode, or the change is invalid. Please refer to the “[5.2 Manual Shutdown](#)” to turn off the inverter.

**INSTRUCTION:**

PVI 36TL PV inverter supports 4 grid standards. Please check with your local electricity supply company before selecting the grid standard. If the inverter is operated with a wrong grid standard, the electricity supply company may cancel the interconnection agreement.

Putting the inverter into operation before the overall system complies with the national rules and safety regulations of the application is not permitted.

4.4.7 System control parameters

The “[1 SysPara](#)” menu has 6 submenus, including “[1 GridVProtect](#)”, “[2 GridFProtect](#)”, “[3 ON/OFF](#)”, “[4 PowerContr](#)”, “[5 LVRTSet](#)” and “[6 OtherProtect](#)”.

(1) “[1 GridVProtect](#)” and “[2 GridFProtect](#)” menus: Set up the parameters of grid voltage, frequency protection and recovery, etc, as shown in Table 4.3:

Table 4.3 - Parameters of Grid Voltage and Frequency (IEEE-1547)

Parameter name	Description	Setup range (lower limit, default & upper limit)
GridV.Max1(V)	Threshold value of Level 1 Max. grid voltage	{200.0, 528.0, 552.0}
VMaxTripT1(S)	Threshold value of Level 1 Max. grid trip voltage	{0, 1.00, 600.00}
GridV.Min1(V)	Threshold value of Level 1 Min. grid voltage	{0, 422.4, 480.0}
VMinTripT1(S)	Threshold value of Level 1 Min. grid trip voltage	{0, 2.00, 600.00}
GridV.Max2(V)	Threshold value of Level 2 Max. grid voltage	{200.0, 576.0, 624.0}
VMaxTripT2(S)	Threshold value of Level 2 Max. grid trip voltage	{0, 0.16, 600.00}
GridV.Min2(V)	Threshold value of Level 2 Min. grid voltage	{0, 240.0, 480.0}
VMinTripT2(S)	Threshold value of Level 2 Min. grid trip voltage	{0, 0.16, 600.00}

GridVmaxRecT(V)	Recovery threshold value of Max. grid voltage	{200.0, 518.0, 533.0}
GridVminRecT(V)	Recovery threshold value of Min. grid voltage	{0, 432.4, 480.0}
GridVRecT(S)	Recovery time of grid voltage protection	{0, 300.00, 600.00}
GridF.Max1(Hz)	Protection threshold value of Level 1 Max. grid frequency	{50.00, 60.50, 66.00}
FmaxTripT1(S)	Trip time of Level 1 Max. grid frequency	{0, 0.16, 600.00}
GridF.Min1(Hz)	Protection threshold value of Level 1 Min. grid frequency	{45.00, 59.30, 60.00}
FminTripT1(S)	Trip time of Level 1 Min. grid frequency	{0, 0.16, 600.00}
GridF.Max2(Hz)	Protection threshold value of Level 2 Max. grid frequency	{50.00, 61.00, 66.00}
FmaxTripT2(S)	Trip time of Level 2 Max. grid frequency	{0, 0.05, 600.00}
GridF.Min2(Hz)	Protection threshold value of Level 2 Min. grid frequency	{45.00, 57.00, 60.00}
FminTripT2(S)	Trip time of Level 2 Min. grid frequency	{0, 0.16, 600.00}
GridFmaxRecT(Hz)	Recovery threshold value of Max. grid frequency	{49.00, 60.40, 66.00}
GridFminRecT(Hz)	Recovery threshold value of Min. grid frequency	{45.00, 59.40, 60.00}
GridFRecT(S)	Recovery time of grid frequency protection	{0, 300.00, 600.00}
GridV.Unbal(%)	Threshold value of grid voltage unbalance	{0.1, 2.6, 10.0}

(2) "3 ON/OFF" menu: Set up the start-up and shut-down control parameters.

Table 4.4 - Start-Up and Turn-Off Control Parameters

Parameter name	Description	Setup range (lower limit, default & upper limit)
PVStartVol(V)	PV start-up voltage	{300.0, 330.0, 400.0}
SoftStep(KW/S)	Soft step	{0.01,1.44,2.88}

SoftOffOption	Soft turn off option	{Disable, Disable, Enable}
OffPStep(KW/S)	Turn off power step	{0.01, 2.16,2.88}
IsoResis(KOhm)	Isolation resistance	{10.0, 250.0 1000.0}
GridReStep(KW/S)	Grid fault recovery step	{0.01, 0.05, 2.88}

(3) "4 PowerContr" menu: relative functions of active, reactive power control and over-frequency derating, including "ActiveContr%", "RePowerContr" and "FregDeratCtrl" menus.

1. "ActiveContr%" menu: adjust the active power of AC output, the range is 0~100.0%.
2. "RePowerContr" menu: set up the reactive power control mode, including 6 submenus: "1. None", "2. Dispatch", "3. Q Set", "4. PF Set", "5. PF(P) Set" and "6. Q(U) Set".

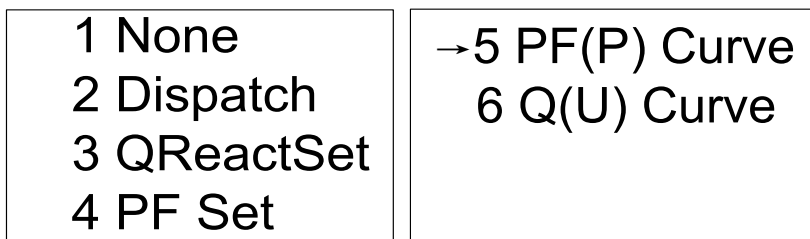

Figure 4.15 - Reactive Power Mode

- 1). None : No mode/disable reactive power mode
- 2). Dispatch : Remote power dispatch mode

Note: The ActivePower, PF and Q value can be adjusted by remote software if the "Dispatch" is selected.

3). QReactSet : Set the Q value

Note: Change the reactive power by adjusting the Q value (reactive compensation)

4). PF Set : Set the PF value

Note: Change the reactive power by adjusting the PowerFactor

5). PF(P) Curve : PF curve mode

Note: The power factor changes according to the power change, as shown in Figure 4.16:



INSTRUCTION:

The PF (P) Curve function is only available for VDE-4105, CEI 0-21 and IEEE-1547 grid standards.

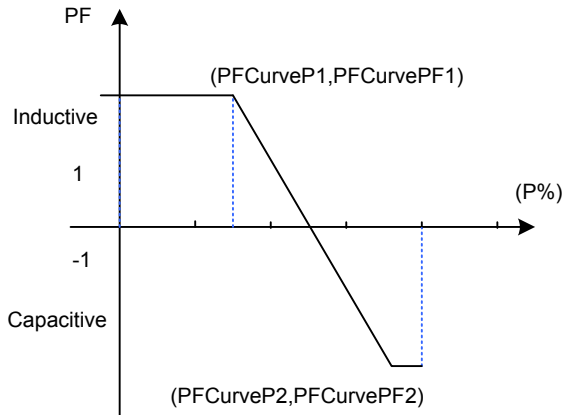

Figure 4.16 - PF(P) Curve Mode

6). Q(U) Curve : Q(U) curve mode

Note: The reactive compensation changes according to the grid voltage change, as shown in Figure 4.17.



INSTRUCTION:

The Q(U) curve function is only available for CEI 0-21 and IEEE-1547 grid standards.

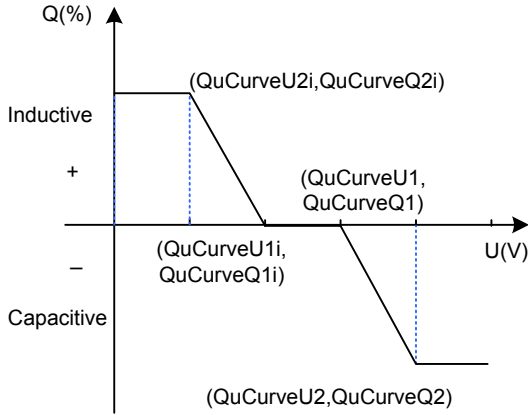

Figure 4.17 - Q(U) Curve Mode

The Table 5-5 lists the parameters of QReactSet, PF Set, PF(P) Curve and Q(U) Curve modes. Press **ENT** to start up the modes after the parameters are set up.

Table 4.5 - Parameters of Reactive Power Control (IEEE-1547)

Mode	Parameter Name	Setup range (lower limit, default & upper limit)	Description
Q	ReactiveComp(%)	(-60.0%, 0.0%, 60.0%)	
PF	PowerFactor	(-0.80, 1.000, 0.80)	
PF(P)	PFCurveP1(%)	(0, 50.0%, 100.0%)	See Figure 5-17
	PFCurvePF1	(-0.800, 1.000, 0.800)	See Figure 5-17
	PFCurveP2(%)	(0, 100.0%, 100.0%)	See Figure 5-17
	PFCurvePF2	(-0.800, -0.900, 0.800)	See Figure 5-17
	PFCurvTripV(V)	(480.0, 480.0, 528.0)	PF curve trip voltage
	PFCurveReV(V)	(422.4, 432.0, 480.0)	PF curve revocation voltage
Q(U)	QuCurveU1(V)	(480.0, 518.4, 528.0)	See Figure 5-18
	QuCurveQ1(%)	(-100.0%, 0.0%, 100.0%)	See Figure 5-18
	QuCurveU2(V)	(480.0, 528.0, 528.0)	See Figure 5-18

QuCurveQ2(%)	(-100.0%, -50.0%, 100.0%)	See Figure 5-18
QuCurveU1i(V)	(422.4, 441.6, 480.0)	See Figure 5-18
QuCurveQ1i(%)	(-100.0%, 0.0%, 100.0%)	See Figure 5-18
QuCurveU2i(V)	(422.4, 432.0, 480.0)	See Figure 5-18
QuCurveQ2i(%)	(-100.0%, 50.0%, 100.0%)	See Figure 5-18
QuCurvTripP(%)	(5.0%, 20.0%, 100.0%)	Qu curve trip power
QuCurveReP(%)	(5.0%, 5.0%, 100.0%)	Qu curve revocation power

3. “FreqDeratCtrl” menu: Set up the parameters of over-frequency active power derating.



INSTRUCTION:

The “FreqDeratCtrl” function is not available for the IEEE-1547 grid standard.

(4) “6 OtherProtect” menu: set up the threshold value of leakage current and output DC component protection:

Table 4.6 - Protection Parameters of Leakage Current and Output DC Component

Parameter name	Description	Setup range (lower limit, default & upper limit)
LeakCurMax(mA)	Leakage current Max. limit	{300, 300, 500}*
IdcMax(mA)	DC component current Max. limit	{216, 216, 500}*

* UL 1741 ground fault requirements

4.4.8 Arc Fault Current Interruption

PVI 36TL is embedded with Type 1 DC arcing fault current detection device which stops the inverter from working when arcing fault current is detected on the DC side and shows “ARC Protect” on the LCD. This fault can only be cleared by manual operation.



Figure 4.18 - ARC Protect Fault

In the “System Setting”→“OtherCmd” menu, execute the “AFCI Test”, the inverter will stop working and test AFCI. When the test is over, “TestFinish” will be displayed on the LCD if no fault is detected or “AFCI Fault” will be shown if a fault occurs, as shown in Figure 4.20.

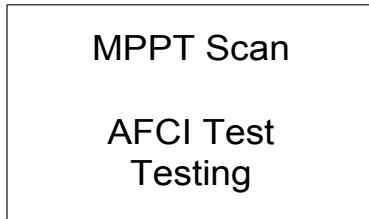

Figure 4.19 - AFCI Test

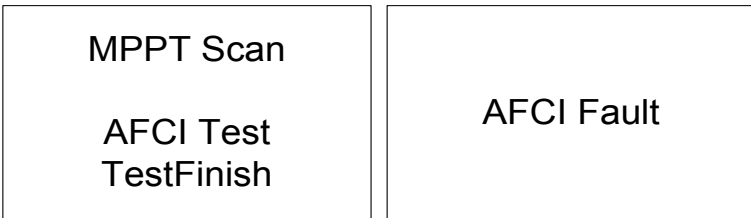

Figure 4.20 - AFCI Test Result

In the “System Setting”→“OtherCmd” menu, execute “ARCFaultClear” command to clear “ARC Protect” fault alarm, and LCD will show “Succeed” if the fault is successfully cleared, as shown in Figure 4.21.

AFCIOperation
Enable
ARCFaultClear
Succeed

Figure 4.21 - Manually Clear "ARC Protect" Fault

5.0: Operation

5.1 Start-up

Manual Start-up: Manual start-up is required after regulation setting or manual (fault) shut-down. Move the cursor from the main operation interface to “4 Setting”. Press **ENT** and go to submenu “1 ON/OFF”. Then move the cursor to “ON” and press **ENT** to start the inverter. Then the inverter will start up and operate normally if the start-up conditions are met. Otherwise, the inverter will go to stand-by mode.

Automatic Start-up: The inverter will start up automatically when the output voltage and power of PV arrays meet the set values, AC power grid is normal, and the ambient temperature is within allowable operating range.

5.2 Shutdown

Manual Shutdown: Normally, it is not necessary to shutdown the inverter, but it can be shut down manually if regulation setting or maintenance is required.

Move the cursor from the main operation interface to “4 Setting”. Press **ENT** and go to submenu “1 ON/OFF”. Move the cursor to “OFF” and press **ENT**, and then the inverter will be shut down.

Automatic Shutdown: The inverter will be shut down automatically when the output voltage and power of PV modules are lower than the set values, or AC power grid fails; or the ambient temperature exceeds the normal range.

5.3 Operation Mode

There are 4 operation modes. The following are corresponding indications for each mode.

- (1) System check mode for startup, as shown in Figure 5.1:

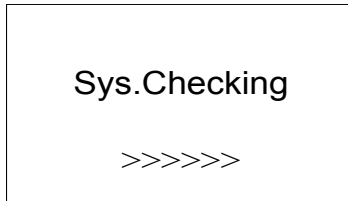

Figure 5.1 - System Self-Check Ongoing

This mode indicates that the inverter is checking whether it is ready for normal operation after the manual start-up of inverter.

- (2) Normal operation mode: Default indication interface for normal operation is shown in Figure 5.2 (a) and 5.2 (b). The switching time between (a) and (b) is 5 seconds.

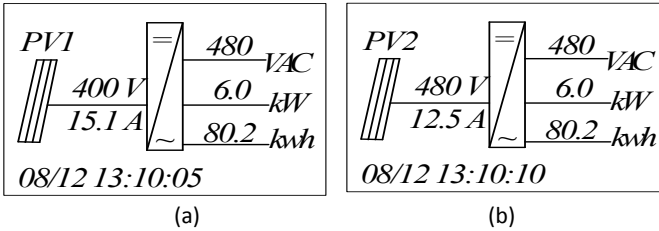

Figure 5.2 - Default Indication Interface for Normal Operation

In this mode, the inverter converts the power generated by PV modules to AC continuously and feeds into the power grid.

(3) Standby mode, as shown in Figure 6-3:

The inverter will enter standby mode when the output voltage and power of PV modules do not meet the startup conditions or PV voltage and input power are lower than the set values. The inverter will check automatically whether it meets the startup conditions in this mode until it turns back to normal mode. The inverter will switch from standby mode to fault mode if a malfunction occurs.



Figure 5.3 - Inverter System in Standby Mode

(4) Fault mode, as shown in Figure5.-4:

The inverter will disconnect from the power grid and turn into fault mode when the inverter or power grid fails. Check the specific cause in “Troubleshooting table” (Table 6.2) according to the fault message displayed on the LCD and eliminate the fault referring to the instructions.

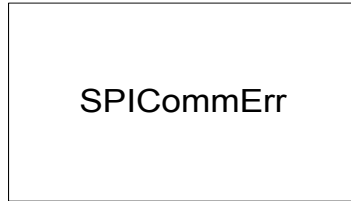

Figure 5.4 - Fault Indication Interface



WARNING:

All the installation and wiring connections should be performed by qualified technical personnel. Disconnect the inverter from PV modules and the AC supply before undertaking maintenance.

Do not operate or maintain the inverter until at least 5 minutes after disconnecting all sources of DC and AC.

5.4 Grid-Tied Power Generation

PVI 36TL series inverter has an automatic grid-tied power generation process. It will check whether AC power grid meets the conditions for grid-tied power generation constantly, and test whether the PV array has enough adequate energy. After all conditions are met, the inverter will enter grid-tied power generation mode. While in the grid-tied power generation, the inverter can detect the power grid at all times, and also keep the photovoltaic array output in maximum power point tracking (MPPT) mode. In case of any abnormality, the inverter will enter the protection program immediately. In low light conditions when power generation is not enough to keep the inverter in operation, the inverter will enter standby mode. When the voltage of PV array changes and becomes stable and higher than the required set value, the inverter will attempt to start grid-tied power generation again.

6.0: Maintenance and De-Installation

6.1 Fault Shutdown and Troubleshooting

6.1.1 LED Fault and Troubleshooting

When contacting Solectria for support please provide the serial number of the inverter, and the fault message. If the fault is regarding any voltage issue please also measure the AC and DC voltage at the inverter prior to calling.

Please refer to the definition of LED lights in Table 4.1 and troubleshoot according to Table 6.1:

Table 6.1 - Troubleshooting of LED Lights

LED fault status	Solutions
Neither the " <u>Power</u> " LED nor the LCD lights up.	<ol style="list-style-type: none"> 1. Turn off the external AC breaker 2. Switch the DC switch to "OFF" position 3. Check the PV input voltage and polarity
The " <u>GRID</u> " LED is blinking.	<ol style="list-style-type: none"> 1. Turn off the external AC breaker 2. Switch the DC switch to "OFF" position 3. Check whether the grid voltage is normal and whether the cable connection of AC side is correct and secure
The " <u>RUN</u> " LED lights off or " <u>FAULT</u> " LED lights up.	Refer to Table 7-2 for troubleshooting

6.1.2 LCD fault and troubleshooting

The inverter will be shut down automatically if the PV power generation system fails, such as output short circuit, grid overvoltage / under voltage, grid over frequency / under frequency, high environmental temperature or internal malfunction of the machine. The fault information will be displayed on the LCD. Please refer to "4.4.2 Present Fault" for detailed operation.

The causes of a fault can be identified based on the faults listed in Table 6.2. Proper analysis is recommended before contacting after-sales service. There are 3 types of fault: alarm, protection and hardware fault.

Table 6.2 - LCD Troubleshooting Table

Alarm	1.TempSensorErr	<p>Definition: Prompt detection of abnormal temperature</p>
		<p>Possible causes: 1.Temperature sensor is reading -25C 2.Temperature Sensor socket connector has poor contact; 2.Temperature Sensor is damaged;</p>
		<p>Recommended solutions: 1.Observe temperature display; 2.Switch off 3-phase working power supply and then reboot the system; 3.Contact after-sales service personnel, inverter may need replacement.</p>
	2.CommErr	<p>Definition: Communication inside inverter fails</p>
		<p>Possible causes: Terminal block connectors of internal communication wires have poor contact</p>
		<p>Recommended solutions: 1.Observe for 5 minutes and see whether the alarm will be eliminated automatically; 2.Switch off 3-phase working power supply and then reboot the system; 3.Contact after-sales service personnel</p>
	3.ExtFanErr	<p>Definition: Cooling fan failure, fan operates based on load and temperature with variable speed control</p>
		<p>Possible causes: 1.Fan is blocked; 2.Fan service life has expired; 3. Fan socket connector has poor contact.</p>
		<p>Recommended solutions: 1.Observe for 5 minutes and see whether the alarm will be eliminated automatically; 2.Check for foreign objects on fan blades; 3.Switch off 3-phase work power supply and then</p>

		<p>reboot the system; 4.Contact after-sales service personnel</p>
	<p>4.EepromErr</p>	<p>Definition: Internal alarm</p>
		<p>Possible causes: Internal memory has a problem</p>
		<p>Recommended solutions: 1.Observe for 5 minutes and see whether the alarm will be eliminated automatically; 2. The inverter is still producing power normally 3.Contact after-sales service personnel</p>
<p>Protection</p>	<p>1.TempOver</p>	<p>Definition: Ambient or internal temperature is too high >70C</p>
		<p>Possible causes: 1.Ambient temperature outside the inverter is too high, very temperature is not over 70C; 2. Fan is blocked; 3. Convection airflow is insufficient due to improper installation.</p>
		<p>Recommended solutions: 1.Confirm that external ambient temperature is within the specified range of operating temperature; 2.Check whether air inlet is blocked; 3.Check whether fan is blocked; 4.Check whether the location of installation is appropriate or not; 5.Observe for 30 minutes and see whether the alarm will be eliminated automatically; 6.Contact after-sales service personnel</p>
	<p>2.GridV.OutLim</p>	<p>Definition: Grid voltage exceeds the specified range,</p>
		<p>Possible causes: 1.Grid voltage is abnormal or not present; Power grid breaks down 2.Cable connection between the inverter and the grid is poor;</p>
		<p>Recommended solutions: 1.Observe for 10 minutes and see whether the alarm will be eliminated automatically; 2.Check whether the grid voltage is within the specified range, verify the AC circuit breaker has not tripped;</p>

		<p>3.Measure VAC between line to line and line to neutral if more than 2.6% difference go to step 5</p> <p>4.Check whether the cable between the inverter and power grid is disconnected or has any fault;</p> <p>5.Contact after-sales service personnel</p>
3.GridF.OutLim	<p>Definition: Grid voltage frequency is abnormal, or power grid is not detected</p>	
	<p>Possible causes: 1.Grid frequency is abnormal; 2.Cable connection between the inverter and the grid is poor;</p>	
	<p>Recommended solutions: 1.Observe for 10 minutes and see whether the alarm will be eliminated automatically; 2.Verify whether the grid frequency is within the specified range; 3.Check whether the cable between the inverter and power grid is disconnected or has any fault; 4.Contact after-sales service personnel</p>	
4.PV VoltOver*	<p>Definition: PV voltage exceeds the specified value</p>	
	<p>Possible causes: PV over-voltage</p>	
	<p>Recommended solutions: 1.Observe for 30 minutes and see whether the alarm will be eliminated automatically; 2.Check whether PV voltage exceeds the specified range; 3.Turn off the PV input switch, wait for 5 minutes, and then turn on the switch again; 4.Contact after-sales service personnel</p>	
5.PV1 (2) Reverse**	<p>Definition: PV module is connected inversely</p>	
	<p>Possible causes: PV positive pole and negative pole are connected inversely;</p>	
	<p>Recommended solutions: 1.Check whether positive pole and negative pole are connected inversely; 2.Contact after-sales service personnel</p>	
6.GFCI.Err	<p>Definition:</p>	

		System leakage current is too high
		Possible causes: 1.Excessive parasitic capacitance on PV module due to environmental factor; 2.Grounding is abnormal; 3. Internal inverter fault
		Recommended solutions: 1.Observe for 10 minutes and see whether the alarm will be eliminated automatically; 2.Detect whether the electrical connection is abnormal 3.Contact after-sales service personnel
	7.IsolationErr	Definition: Insulation impedance of PV positive to ground or PV negative to ground exceeds the specified range
		Possible causes: Air humidity is high
		Recommended solutions: 1.Observe for 10 minutes and see whether the alarm will be eliminated automatically; 2.Check insulation of PV system; 3.Contact after-sales service personnel
	8.ARC Protect	Definition: Arc-fault
		Possible causes: Protection actions of ARC board
		Recommended solutions: 1. Use “ARCFaultClear” to clear the Arc-fault. (Refer to section 5.4.4) 2. Check if there is an arc in PV input or the connection of PV cable is not good. 2. Contact after-sales service personnel
9.Arcboard Err	Definition: Arcboard error	
	Possible causes: Poor contact or damage of Arcboard	
	Recommended solutions: 1. Check whether the Arcboard is in good condition 2. Use “ARCFaultClear” to clear the Arc-fault. (Refer to section 5.4.4) 3. Contact after-sales service personnel	

	10.IntProtect0010~0620	Definition: Internal protection of the inverter Possible causes: Protection procedure occurs inside the inverter Recommended solutions: 1.Observe for 10 minutes and see whether the alarm will be eliminated automatically; 2.Contact after-sales service personnel
Fault	IntFault0010~0150	Definition: Internal fault of the inverter Possible causes: Fault occurs inside the inverter Recommended solutions: 1.The inverter can be forced to restart once it is required by operation and if it is confirmed that there is no other problem; 2.Contact after-sales service personnel



INSTRUCTION:

- *The actual display of “PV.VoltOver” is “PV1VoltOver” or “PV2VoltOver”.
- *The actual display of “PV.Reverse” is “PV1Reverse” or “PV2Reverse”.



DANGER:

Please disconnect the inverter from AC grid and PV modules before opening the equipment. Make sure hazardous high voltage and energy inside the equipment has been discharged.
Do not operate or maintain the inverter until at least 5 minutes after disconnecting all sources of DC and AC.

6.2 Product Maintenance

6.2.1 Check the Electrical Connection

Check all the cable connections as a regular maintenance inspection every 6 months or once a year.

- 1.) Check the cable connections. If loose, please tighten all the cables referring to “2.3 Electrical Installation”.
- 2.) Check for cable damage, especially whether the cable surface is scratched or smooth. Repair or replace the cables if necessary.

6.2.2 Clean the Air Vent Filter

The inverter can become hot during normal operation. It uses built in cooling fans to provide sufficient air flow to help in heat dissipation.

Check the air vent regularly to make sure it is not blocked and clean the vent with soft brush or vacuum cleaner if necessary.

6.2.3 Replace Cooling Fans

If the internal temperature of the inverter is too high or abnormal noise is heard assuming the air vent is not blocked and is clean, it may be necessary to replace the external fans. Please refer to Figure 6.1 for replacing the cooling fans.

- 1.) Use a No.2 Phillips head screwdriver to take off the 10 screws on the fan tray (6 screws on the upper fan tray, and 4 screws on the lower fan tray).
- 2.) Disconnect the waterproof cable connector from the cooling fan.
- 3.) Use a No.2 Phillips head screwdriver to take off the screws.
- 4.) Fix the new cooling fan on the fan tray, and fasten the cable on the fan tray with cable ties

Torque value: 0.8-1N.m (8 in-lbs)

- 5.) Install the assembled fans back to the inverter.

Torque value: 1.2N.m (10 in-lbs)

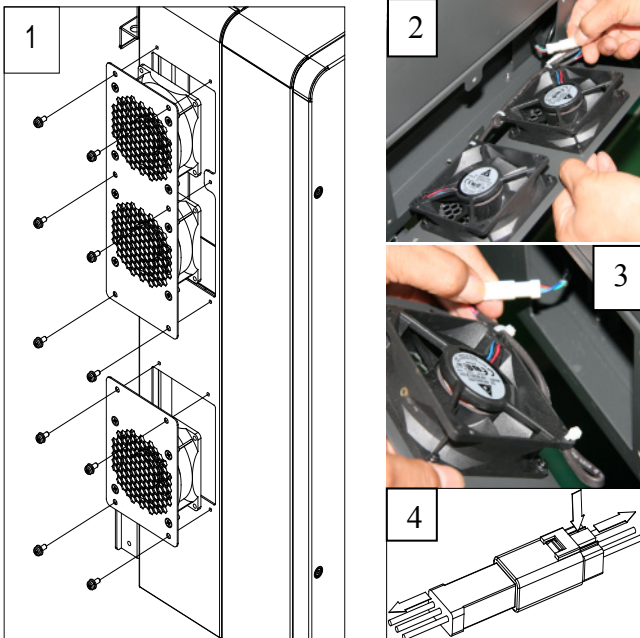

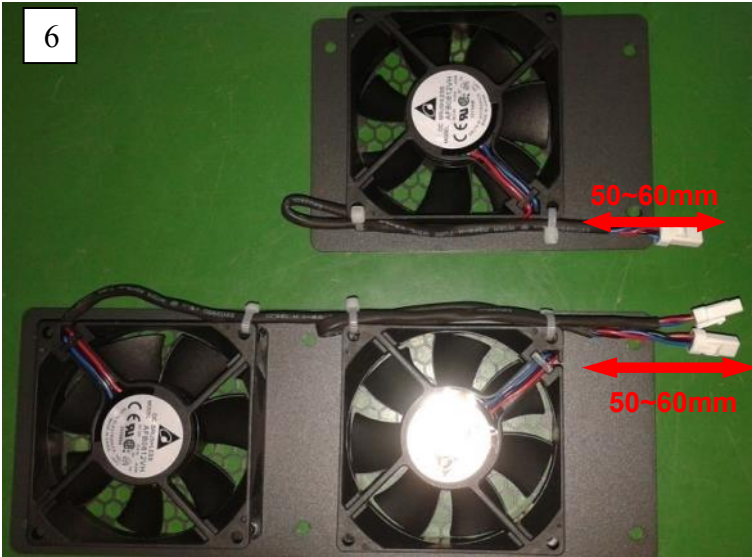
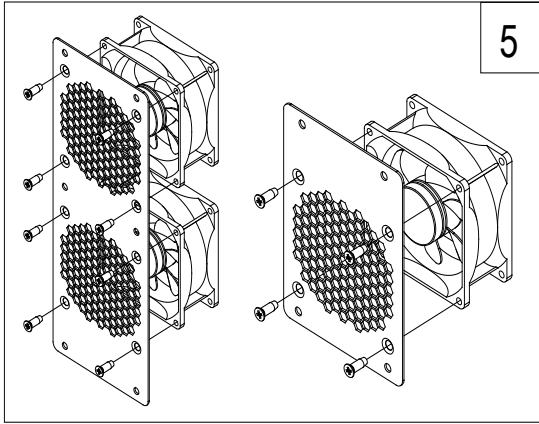

Figure 6.1 - Replace Cooling Fans

6.2.4 Replace the Inverter

Please confirm the following things before replacing the inverter:

- (1) The inverter is turned off.
- (2) The DC switch of the inverter is turned to OFF position.

Then Replace the inverter according to the following steps:

a.) Unlock the padlock if it is installed on the inverter.

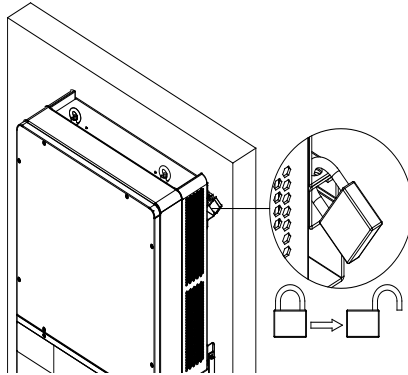

Figure 6.2 - Unlock the Padlock

b.) Use a No.2 Phillips head screwdriver to unscrew the 2 screws on both sides of the inverter.

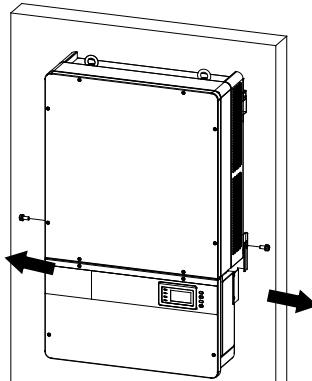

Figure 6.3 - Remove the Screws on Both Sides

c.) Use a No. 10 Hex wrench to remove the 4 screws between the main section and the wiring box. Lift up the main section and disconnect from the wiring box.

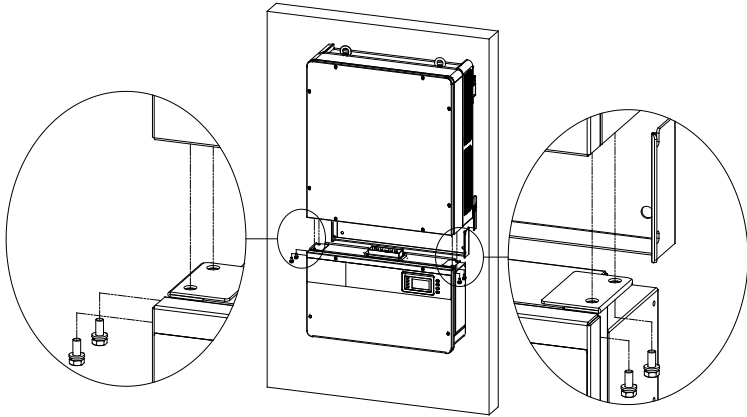

Figure 6.4 - Disconnect the Main Section from the Wiring Box

d.) Use a No.2 Phillips head screwdriver to remove the 2 screws on the left side of the wiring box, and take off the cover board. Put the board on the connector of wiring box.

Torque value: 1.2N.m (10 in-lbs)

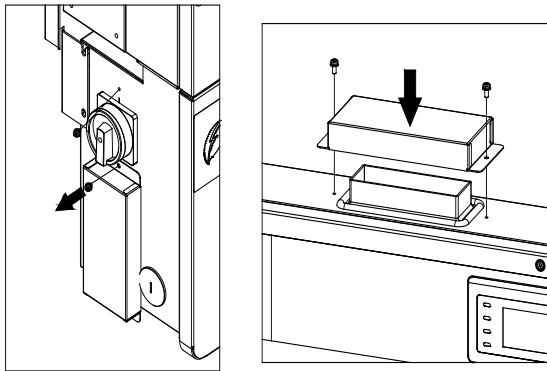

Figure 6.5 - Install the Cover Board on the Connector of the Wiring Box

6.3 Uninstalling the Inverter

Uninstall the inverter according to the following steps when the service time is due or for other reasons:

**DANGER:**

Please disconnect the electrical connection in strict accordance with the following steps. Otherwise, the inverter will be damaged and the service personnel's life will be endangered.

- 1.) Turn off the AC breaker, and use Padlocks if provided.
- 2.) Turn off the DC breaker, and use Padlocks if provided.
(Skip this step if there is no DC circuit breaker.)
- 3.) Switch the AC switch to "OFF" position.
- 4.) Switch the DC switch to "OFF" position.
- 5.) Wait for 10 minutes to ensure the internal capacitors have been completely discharged.
- 6.) Measure the AC output cable terminal voltage against the ground, and make sure the voltage is 0V.
- 7.) Disconnect the AC and PE cables referring to "2.3.2 AC and Ground Connection".
- 8.) Disconnect the DC cables referring to "2.3.1 DC Connection".
- 9.) Uninstall the inverter using reverse of installation steps referring to "2.2 Mechanical Installation".

7.0: Technical Data

Model Name	PVI 36TL
DC Input	
Max. PV Power	54kw
Nominal DC Input Power	37kW
Max. DC Input Voltage ¹	1000Vdc
Operating DC Input Voltage Range	200-950Vdc
Start-up DC Input Voltage / Power	330V/80W
Number of MPP Trackers	2
MPPT Voltage Range ²	540-800Vdc
Max. Input Current (Imp)	35A*2
Max. Short Circuit Current (Isc)	50A*2
Number of DC Inputs	8 inputs, 4 per MPPT
DC Disconnection Type	Load rated DC switch
AC Output	
Rated AC Output Power	36kW
Max. AC Output Power	36kW
Rated Output Voltage	480Vac
Output Voltage Range ³	422-528Vac
Grid Connection Type	3Φ/ PE
Max AC Output Current	43.5A
Rated Output Frequency	60Hz
Output Frequency Range ⁴	59.3-60.5Hz
Power Factor	>0.99 (±0.8 adjustable)

¹ Exceeding the Max. DC Input Voltage may cause permanent damage to the equipment.

² The MPPT Voltage Range is adjustable through LCD operations.

³ The Output Voltage Range may differ according to specific grid standard.

⁴ The Output Frequency Range may differ according to specific grid standard.

Current THD	<3%
AC Disconnection Type	Load rated AC switch
System	
Topology	Transformerless
Max. Efficiency	98.4%
CEC Efficiency	98.0%
Stand-by / Night Consumption	<30W / <3W
Environment	
Protection Degree	TYPE 4X
Cooling	Variable speed cooling fans
Operating Temperature Range	-13°F to +140°F / - 25°C to +60°C (derating from +113°F / +45°C)
Storage temperature	-40°F to +158°F / - 40°C to +70°C
Operating Humidity	0-95%, non-condensing
Operating Altitude	13123.4ft / 4000m (derating from 6561.7ft / 2000m)
Display and Communication	
Display	LCD + LED
Communication	Standard: RS-485 (Modbus) Optional: Ethernet TCP/IP card
Mechanical Data	
Dimensions (WxHxD)	23.6×39.4×9.1in / 600×1000×230mm
Weight	145lbs / 66kg (main section & inverter)
Orientation	15 - 90 degrees from horizontal
Safety	
PV Arc-Fault Circuit Protection	Type 1
Safety and EMC Standard	UL1741:2010, CSA-C22.2 NO.107.1-01, IEEE1547; FCC PART15
Grid Standard	IEEE1547: 2003, IEEE1547.1: 2006

Note 1: When the DC input voltage is lower than 540V or higher than 800V, the inverter begins derating, as shown in Figure 7.1:

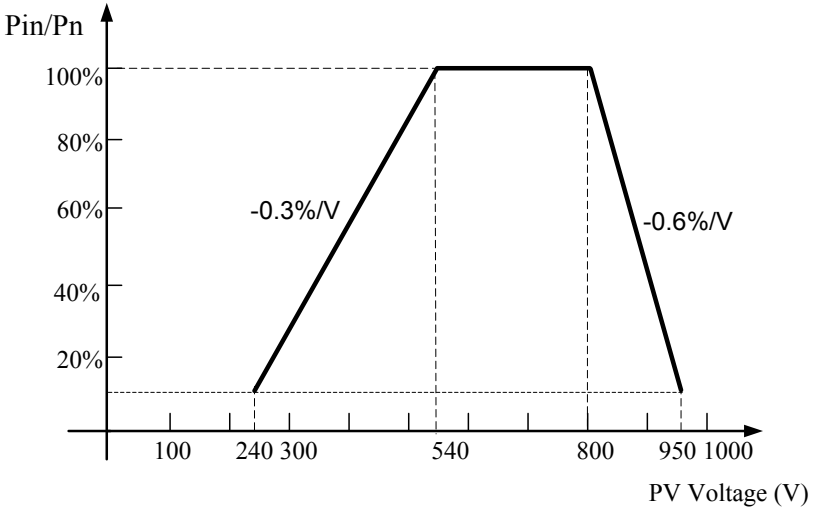

Figure 7.1 - PVI 36TL Derating Curve of PV Input Voltage

Note 2: When the ambient temperature is higher than 113°F (45°C), the output power begins derating, as shown in Figure 7.2:

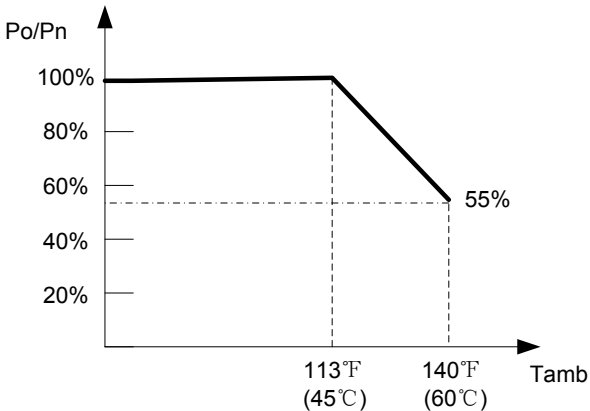

Figure 7.2 - PVI 36TL Derating Curve with High Temperature

Note 3: When the altitude is higher than 9843ft (3000m), the power of the inverter will start derating, as shown in Figure 7.3:

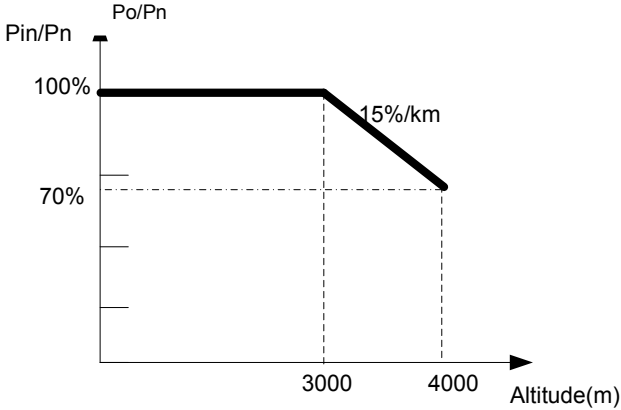

Figure 7.3 - PVI 36TL Derating Curve with High Altitude

Note 4: The inverter can output the AC power with full loads within 90%~110% of the rated grid voltage. When the grid voltage is lower than 90%, the output current will be limited within the allowable Max. current.

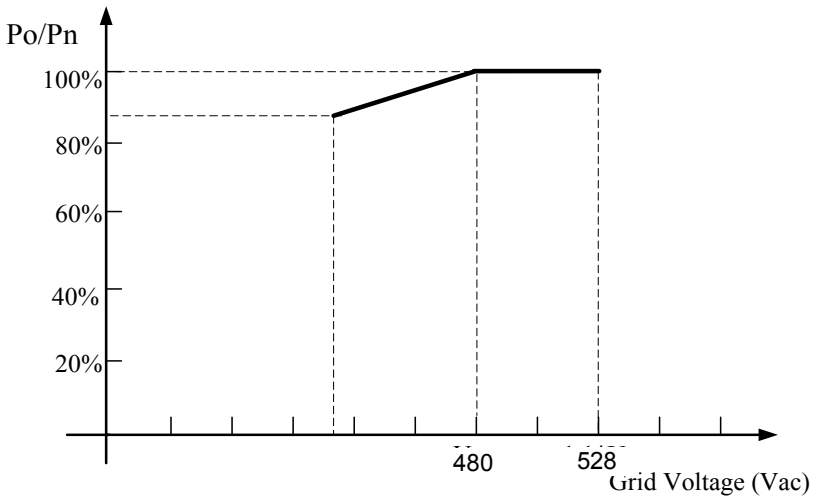

Figure 7.4 - PVI 36TL Derating Curve of Grid Voltage

8.0: Accessory Options

The PVI 36TL comes with several options that allow the inverter to support a wide range of real life applications.

8.1 Fuse Bypass

OPT-FUSEBYPASS-PVI-23-28 allows customers to combine the DC inputs outside the inverter and enter with only one or two combined inputs. Torque to 16 in-lbs the provided hardware.

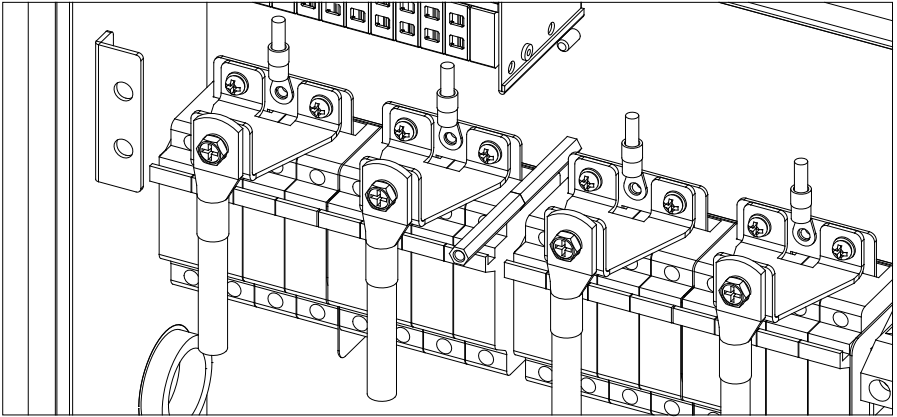

Figure 8.1 – Fuse Bypass Two Inputs (Two Independent MPPTs)

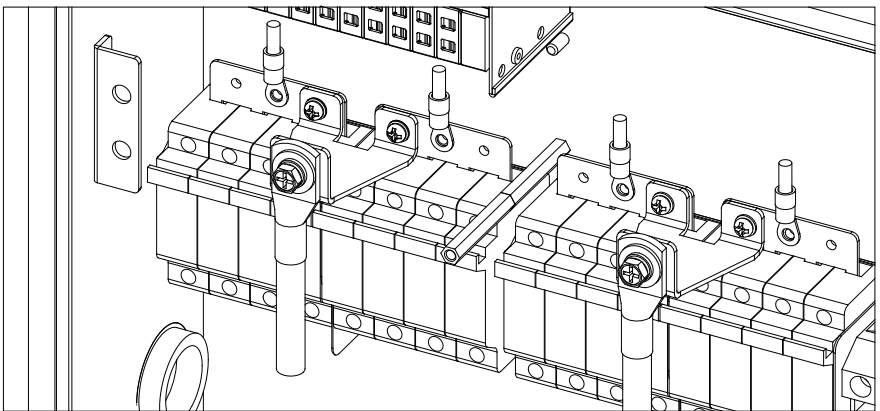

Figure 8.2 – Fuse Bypass Single Input (Combined MPPT)

8.2 SolrenView Monitoring

OPT-SRV-LCD allows customers to purchase the only monitoring system that is designed to support PVI 36TL to the fullest. SolrenView can be placed inside the inverter so no external enclosure is needed. RS-485 and DC wires can be fed into SolrenView directly off of the inverter.



Figure 8.3 – SolrenView Monitoring Installed Inside Wiring Box

8.3 Shade Cover

OPT-SHADECOVER-PVI-23-28 is specifically designed for inverters mounted at a 15-degree tilt angle. It protects the inverter from harsh weather and direct sunlight/extremely hot temperatures while reducing thermal gain on the inverter and increasing energy production.

PVEL, now part of BEW/DNV Kema, performed field testing of the shade cover temperature effects of the inverter case temperatures. The normalized data analysis showed 2-15% less temperature rise on the inverter case temperatures. Front, Back and Top temp rise was 6%, 4%, 15% lower with the Shade cover (as shown in table on the next page).

Measurement Location	Inverter1					
	Top	East	West	Front	Back	Bottom
Without Shade Plate [$T_{Case}/T_{Ambient}$]	1.98	1.53	1.71	1.54	1.47	1.26
Shade Plate on Inverter1 [$T_{Case}/T_{Ambient}$]	1.67	1.47	1.66	1.45	1.41	1.23
Percent Difference [Shade Plate-Without Shade Plate](%)	-15.65	-3.36	-3.01	-6.26	-4.20	-2.34

Table 8.1 – Normalized (to Measure Ambient Temperatures) Case Temperatures at Various Locations on the Inverter

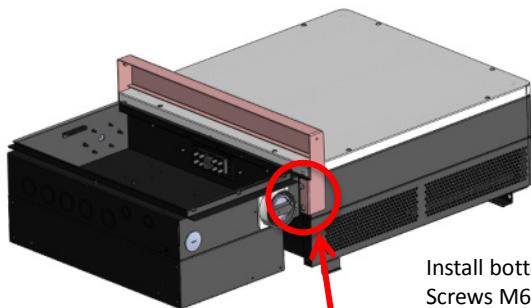

Install bottom bracket as shown.
Screws M6x18- 4 pcs.
Torque to 25 in-lbs.

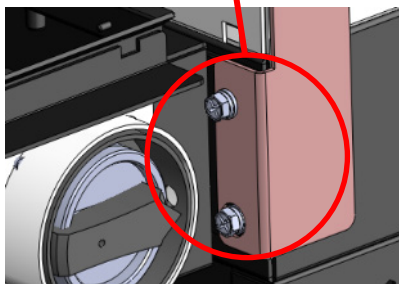

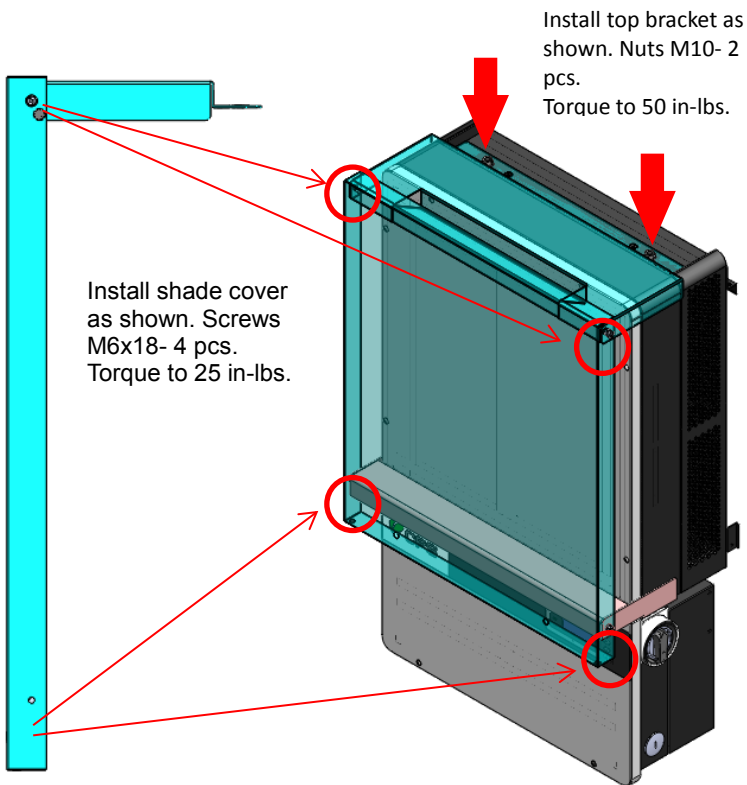

Figure 8.4 –Shade Cover Installation

8.4 AC & DC Disconnect Covers

OPT-DISCOVER-PVI-23-28 is a tamper resistant cover for the AC and DC disconnects. It is for customers that have inverters in public places so the disconnects cannot be turned while the inverter is running.



Figure 8.5 – Tamper Proof Cover

9.0: Appendices:

Appendix A – Instruction of Inverter Selection

Table A.1 - Optional Accessory

	Item	Number	Note
Standard	■ PVI 36TL inverter	1	
Options	□ Ethernet card	1	
	□ Bypass input terminalsx2	1 or 2	

The following figure shows the wiring box equipped with the optional components:
 BYPASS INPUT TERMINAL

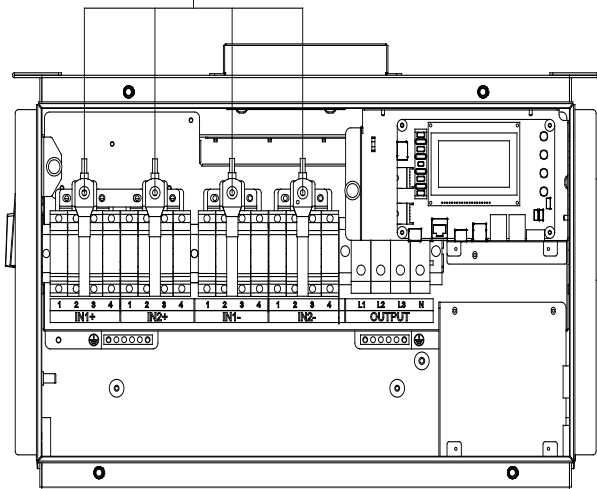
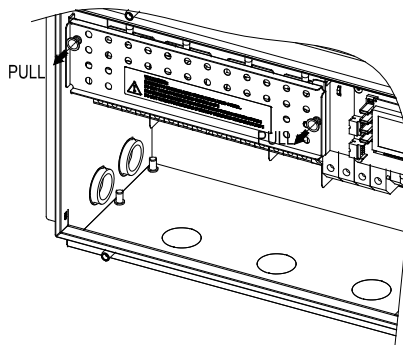
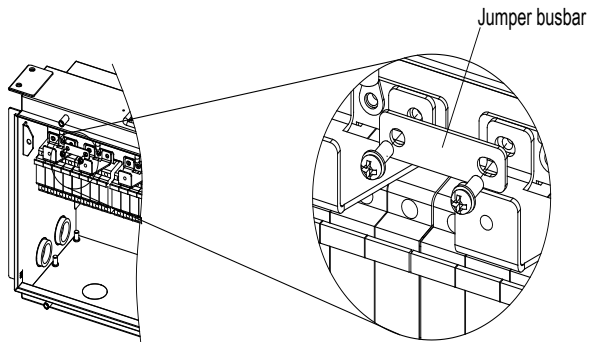

Figure A.1 - Internal Structure of PVI 36TL Inverter with Optional Components

Bypass Input Terminal Instructions:

1. Remove the protection cover. (see Figure A.2)
2. Use No.2 Phillips head screwdriver to remove the jumper busbar, torque value of 1.6N.m. (14 in-lbs) (see Figure A.3)
3. Use No.2 Phillips head screwdriver to install the bypass input terminals, 2sets or 1set, torque value of 1.6N.m. (14 in-lbs) (see Figure A.5)
4. Use No. 10 wrench to screw DC input cable on the bypass input terminals, torque value of 6.0N.m. (50 in-lbs) (see Figure A.6)
5. Reinstall the protection cover (see Figure A.7).

**Figure A.2****Figure A.3**

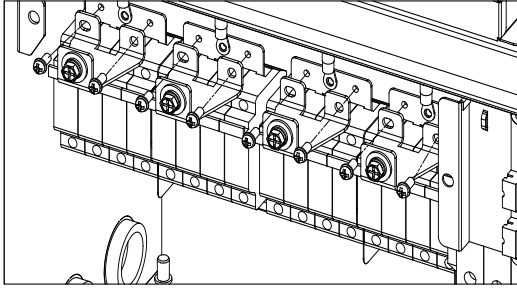

Figure A.4(a)

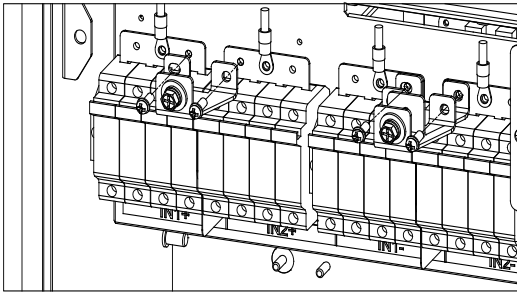

Figure A.4(b)

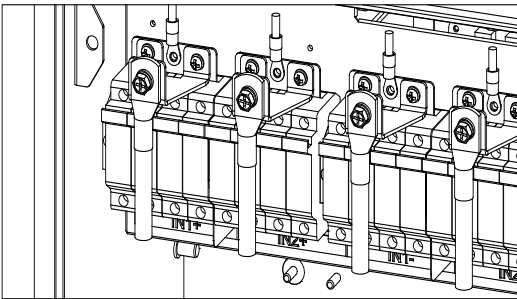

Figure A.5(a)

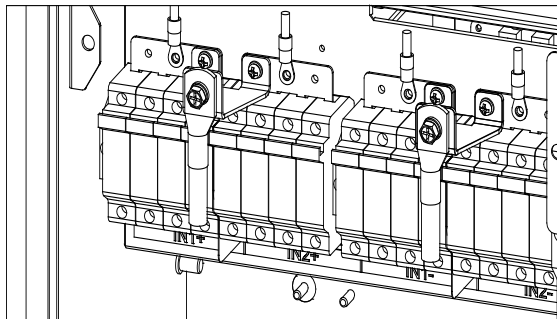

Figure A.5(b)

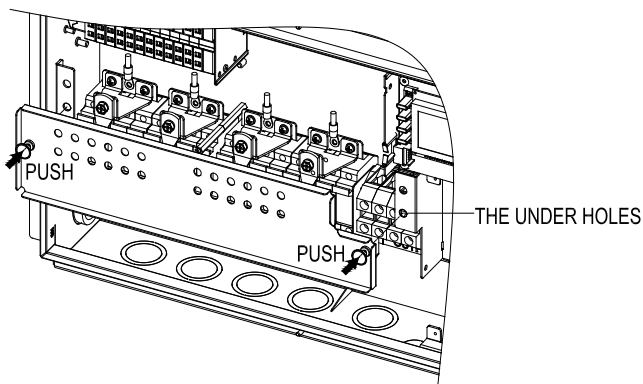

Figure A.6

Appendix B – PVI 36TL Datasheet

<http://solectria.com/support/documentation/inverter-datasheets/pvi-14tl-pvi-20tl-pvi-23tl-pvi-28tl-and-pvi-36tl-transformerless-3-ph-string-inverters/>

Appendix C – String Sizing Tool

<http://solectria.com/support/string-sizing-tool/>

Appendix D – Contact Information

Solectria Renewables, LLC
360 Merrimack Street
Lawrence, Massachusetts 01843
USA

Tel: 978.683.9700
Fax: 978.683.9702
Sales Support: inverters@solectria.com
Customer Support: service@solectria.com
Website: www.solectria.com

Appendix E – Authorized Distributors

Please visit:
<http://www.solectria.com/products/how-to-buy/>

Appendix F – UL 1741 / UL 1699B/ IEEE 1547 / CSA 22.2#107.1 Authorization to Mark



Certificate of Compliance

Certificate: 2665124

Master Contract: 259363

Project: 70036193

Date Issued: June 12, 2015

Issued to: Solectria Renewables, LLC.
360 Marrimack St Bldg 9,
Lawrence,
MA, 01843,
USA

Attention: Mr. James Worden

The products listed below are eligible to bear the CSA Mark shown with adjacent indicators 'C' and 'US' for Canada and US or with adjacent indicator 'US' for US only or without either indicator for Canada only



Kyle Song
Issued by: Kyle Song

PRODUCTS

CLASS 5311 09 - POWER SUPPLIES - Distributed Generation Power Systems Equipment
CLASS 5311 89 - POWER SUPPLIES - Distributed Generation - Power Systems Equipment
- Certified to U.S. Standards

Transformerless Utility Interactive Inverter, Models PVI 23TL-480, PVI 28TL-480 and PVI 36TL-480, permanently connected.

Note:

For details related to rating, size, configuration, etc., reference should be made to the CSA Certification Record, Certificate of Compliance Annex A, or the Descriptive Report.