

COTEK

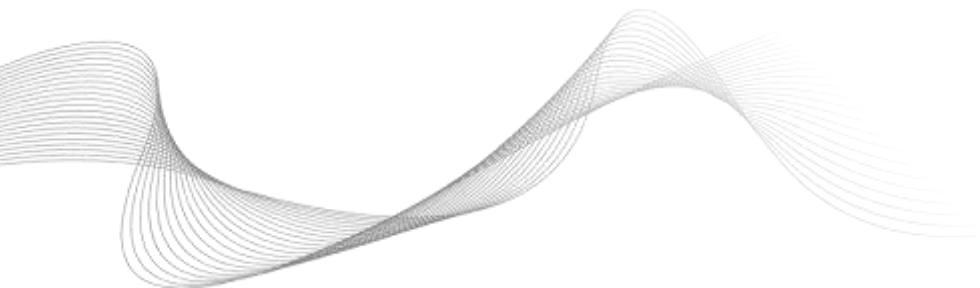

SR-1600 User's Manual

Telecom / Datacom

PURE SINE WAVE INVERTER

Legal Provisions

Copyrights 2016 COTEK Electronic IND. CO. All Rights Reserved.

Any part of this document may not be reproduced in any form for any purpose without the prior written permission of COTEK Electronic IND. CO. For the conditions of the permission to use this manual for publication, contact COTEK Electronic IND. CO., LTD. In all related COTEK product activities, Neither COTEK Electronic IND. CO., LTD. nor its distributors or dealers be liable to anyone for indirect, incidental, or consequential damages under any circumstances.

Specifications are subject to change without notice. Every attempt has been made to make this document complete, accurate and up-to-date. COTEK Electronic IND. CO., LTD reserve the right to make changes without notice and shall not be responsible for any damages, including indirect, incidental or consequential damages, caused by reliance on the material presented, including, but not limited to, omissions, typographical errors, arithmetical errors or listing errors in the content material. All trademarks are recognized even if these are not marked separately. Missing designations do not mean that a product or brand is not a registered trademark.

Table of Content

1. SAFETY INSTRUCTIONS	1
1-1. General Safety Precautions	1
1-2. Other Safety Notes	2
2. FUNCTIONAL CHARACTERISTICS INTRODUCTION	3
2-1. System	3
2-2. Electrical Specification	4
2-3. Mechanical Drawings	5
2-3-1. SR-1600 Single Module.....	5
2-3-2. SR-1600 Rack (19" 2U).....	6
2-4. SR-1600 De-rating Curve	7
2-5. Protection Mechanism	7
3. INSTALLATION AND MAINTENANCE	8
3-1. Introduction	8
3-1-1. LED Indicator.....	10
3-1-2. Green Terminal Introduction	11
3-1-3. AC Input / Output Terminal	13
3-1-4. Parallel Connection Port.....	13
3-1-5. Battery Cabling	14

3-1-6. Chassis Ground	16
3-1-7. Installation Space Requirement	16
3-1-8. RS-485 Port.....	16
3-2. Parallel Connection	23
3-2-1. Multi-shelves Installation	23
3-2-2. Parallel Connection with Jumper Setting.....	23
3-2-3. Parallel Connection with COTEK iC-Hub	24
3-3. Maintenance	24
3-3-1. Inverter Module Replacement	24
3-3-2. Fan Module Replacement	26
4. TROUBLE SHOOTING	29
5. WARRANTY	30

1. Safety Instructions

1-1. General Safety Precautions



Warning! Before using the Inverter, read the safety instructions.

- Do not expose the inverter to rain, snow, spray or dust. To reduce the risk of fire hazard, do not cover or obstruct the ventilation openings and do not install the inverter in a zero-clearance compartment.
- To avoid the risk of fire and electric shock, make sure that the existing wiring is in good electrical condition, and the wire size is not undersized.
- This equipment contains components which can produce arcs or sparks. To prevent fire or explosion do not install in compartments containing batteries or flammable materials or in locations which require ignition protected equipment. This includes any space containing gasoline-powered machinery, fuel tanks, or joints, fittings, or other connection between components of the fuel system.
- Depending on the user scenario, the AC output of the inverter may require user installed breaker or fuse. In AC output hardwire application, AC socket will not be provided. The inverter incorporates standard AC short circuit protection.
- The following precautions should be taken when working on the inverter :
 - Step 1 Remove watches, rings, or other metal objects
 - Step 2 Use tools with insulated handles
 - Step 3 Wear rubber gloves and boots

1-2. Other Safety Notes

- Upon receipt, examine the carton box for damage. Notify the carrier immediately, before opening, if damage is evident.
- Do not operate near water or in excessive humidity.
- Do not open or disassemble the inverter, as warranty may be voided.
- The DC side connections should be firm and tight.
- Grounding : Reliable grounding should be maintained.
- Do not drop a metal tool on the battery. The resulting spark or short-circuit on the battery or on the other electrical part may cause an explosion.
- Install the inverter in a well-ventilated area. Do not block the front air vents, or the rear air exhausts of the unit.
- Wiring : Adequate input power must be supplied to the inverter for proper use; correct wiring sizes must be ensured.
- Mount the inverter such that the fan axis is horizontal.
- Do not operate the inverter close to combustible gas or open fire.
- Do not operate appliances that may feed power back into the inverter.
- Temperature : The inverter should be operated in an ambient temperature range of -25°C to 40°C otherwise the output efficiency may be affected. Air flow to the inverter must not be blocked.

2. Functional Characteristics Introduction

2-1. System

The SR-1600 is a highly reliable, modular design DC-AC inverter system, designed with advanced power electronic and microprocessor technology offering the following features :

- Simple setting and scalable system capacity supports up to 32 pcs (51.2KW)
- Support 1 ϕ and 3 ϕ : suitable for commercial and industrial applications
- Seamless switch between AC and DC source
- Build-in input and output full isolation
- Wide AC input range 150~265V (230V system), 75~132V (120V system)
- High efficiency (~96%)
- Power factor ≥ 0.99
- Advanced Protection Features
 - Input reverse, under-voltage, over voltage protection
 - Output protection : short circuit, over load, over temperature, over voltage protection
- Operating mode
 - AC mode (Default) : The AC utility power is the main source, DC power is the second source, PFC>0.99, Max. efficiency 96~97%. When the AC utility abnormal, the switching time is 0 second.
 - AC Ratio mode : At the same time AC and DC input, the percentage of AC and DC load can be assigned to 100%, if set AC is 70%, then the remaining 30% gap made up by DC.
 - DC mode : DC power is the main source, and AC utility is the second source, THD<3%, Max. efficiency is 91~93%. The switching time between AC and DC power is 0 second.

2-2. Electrical Specification

Electrical	Specification	Model No.			
	Item	SR-1600-124	SR-1600-148	SR-1600-224	SR-1600-248
AC Input	Nominal Voltage	120VAC		230VAC	
	Voltage Range	75~132VAC ± 3%		150~265VAC ± 2%	
	Power Factor	> 0.99 @ rating power			
	Frequency	50 / 60 Hz			
	Synchronization Range	47~53 Hz, 57~63 Hz			
DC Input	Nominal Voltage	24VDC	48VDC	24VDC	48VDC
	Voltage Range	18~34VDC ± 3%	36~68VDC ± 3%	18~34VDC ± 3%	36~68VDC ± 3%
	Nominal Current	56A	37A	56A	37A
	Max. Input Current (15 sec.)	90A	60A	90A	60A
AC Output	Rating Power	1200W/1600VA	1600W/1600VA	1200W/1600VA	1600W/1600VA
	Short Time Overload Capacity	150% rated power (15 seconds)			
	Nominal Voltage	120VAC		230VAC	
	Output Voltage Range	100~120VAC ± 3%		200~240VAC ± 2%	
	Max. Efficiency(AC)	96%		97%	
	Max. Efficiency(DC)	91%	92%	91%	93%
	Frequency	50 / 60Hz			
	THD	< 3% (Above 50% Resistive Load)			
	Turn ON Delay	< 10 seconds			
Crest Factor at Nominal Power	DC mode: 3 times nominal current AC mode: 6 times nominal current		DC mode: 3 times nominal current AC mode: 10 times nominal current		
Control & Signal	Indicator	LED			
	Advanced Control	RS-485 control module			
	Failure Indicator	Buzzer alarm			
Protection	DC Input	Over Voltage / Under Voltage / Reverse Polarity			
	AC Input	Over Voltage / Under Voltage / Over Current			
	Output	Short Circuit / Overload / Over Temperature			
Transfer Performance	Inverter to Utility AC	0 second			
	Utility AC to Inverter	0 second			

Electrical	Specification	Model No.			
	Item	SR-1600-124	SR-1600-148	SR-1600-224	SR-1600-248
Environment	Operating Temp.	-25°C ~ 40°C; refer to SR-1600 power de-rating curve			
	Storage Temp.	-40°C ~70°C			
	Relative Humidity	95%, non-condensing			
	Vibration	BS EN 61373			
Safety & EMC	Safety standards	Meet UL 60950-1		Certificated EN 60950-1	
	EMC standard	Certificated FCC Class B		Certificated EN55022 Class B; EN 61204-3; EN55024; EN 61000-3-2, -3-3, -6-1, -6-3; IEC 61000-4-2, 3, 4, 5, 6, 8, 11	
Others	Dimension-Module	105x83x410 mm / 4.13x3.27x16.14 inch			
	Dimension-Shelf	446x85x509mm / 17.56x3.35x20.04 inch			
	Weight (net)	Module : 3.8kg; 4pcs / Shelf : 6.5kg; 1pcs			

Table 1. SR-1600 specification

2-3. Mechanical Drawings

2-3-1. SR-1600 Single Module



Figure 1. SR-1600 mechanical drawing-single module

2-3-2. SR-1600 Rack (19" 2U)

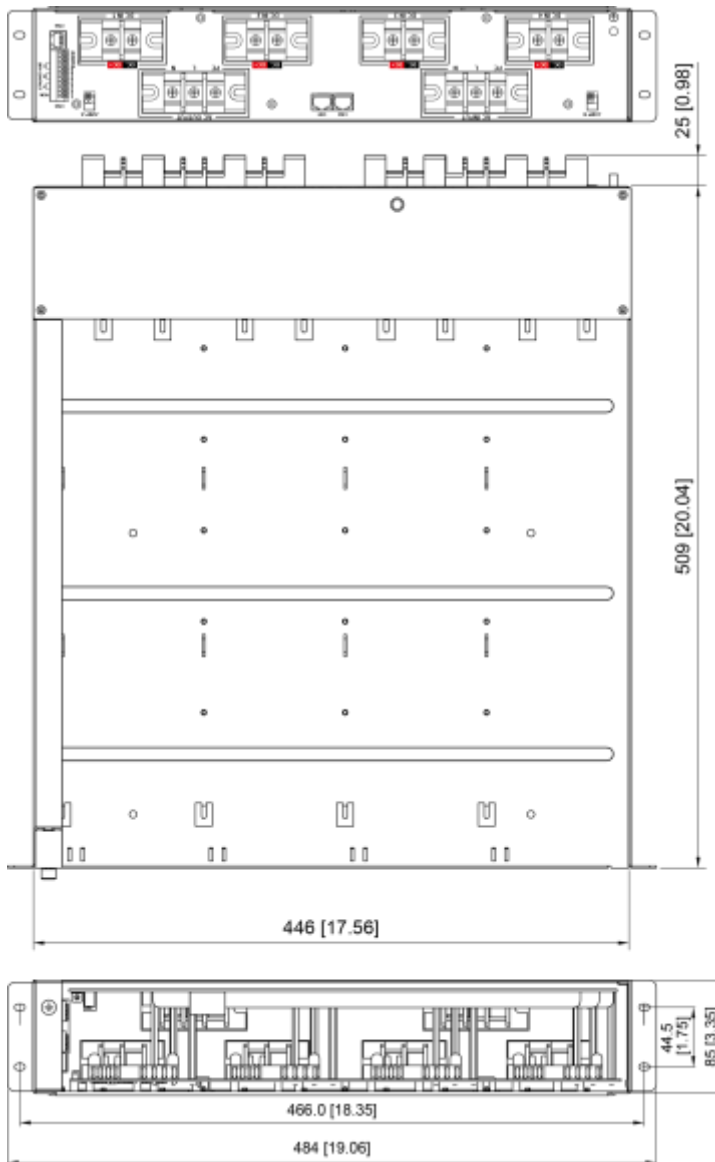

Figure 2. SR-1600 mechanical drawing-rack

2-4. SR-1600 De-rating Curve

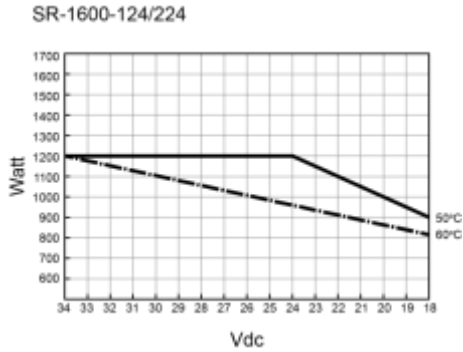

Figure 3. SR-1600 de-rating curve: SR-1600-124/224

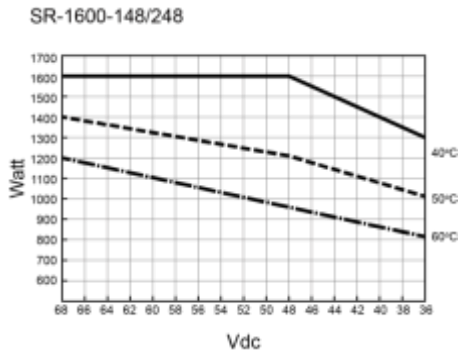

Figure 4. SR-1600 de-rating curve: SR-1600-148/248

2-5. Protection Mechanism

Type	Over Voltage			Under Voltage		
	Shutdown	Restart	Alarm	Shutdown	Restart	Alarm
110 Vac	132.5±3%	127.5±3%	127.5±3%	75±3%	90±3%	90±3%
230 Vac	265±3%	255±3%	255±3%	150±3%	180±3%	180±3%
24 Vdc	34±0.5	28±0.5	33±0.5	18±0.5	25±0.5	21±0.5
48 Vdc	68±1	56±1	66±1	36±1	50±1	42±1

Table 2. SR-1600 protection mechanism

3. Installation and Maintenance

3-1. Introduction

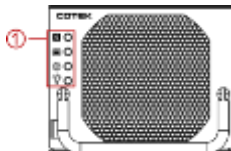

Figure 5. SR-1600 module front panel view

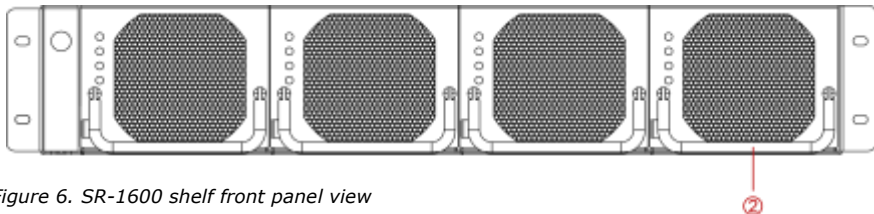

Figure 6. SR-1600 shelf front panel view

Description	
① LED indicator	② Inverter handle

Table 3. SR-1600 description

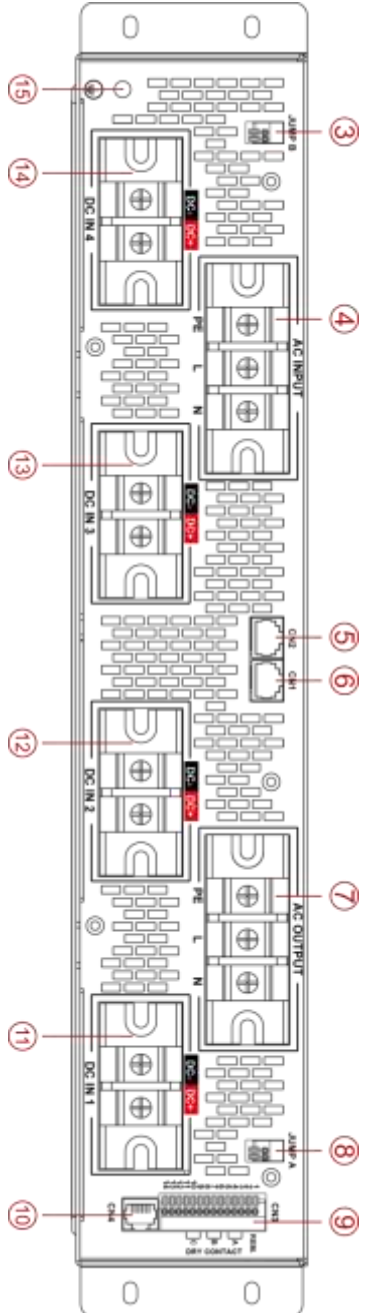





Figure 7. SR-1600 shelf rear panel view

Description	
③ Jumper B (terminal resistor)	⑩ RS-485
④ AC input terminal	⑪ DC input (Battery) #1
⑤ Parallel connection port CN2	⑫ DC input (Battery) #2
⑥ Parallel connection port CN1	⑬ DC input (Battery) #3
⑦ AC output terminal (load)	⑭ DC input (Battery) #4
⑧ Jumper A (terminal resistor)	⑮ Chassis ground
⑨ CN3 Dry contact and remote	

Table 4. SR-1600 description

3-1-1. LED Indicator ①

Icon	Description	Icon	Description
	System status LED indicator		AC input power indicator
	DC battery power indicator		Load indicator

Example: SR-1600-248 Type















Status	LED Indicator				
Green	Off				No output
	 Solid ON	Power by AC (Grid)	Normal (48~66V)	Voltage & Frequency OK	Load 0~60%
	 Fast Blinking	Power by AC & DC (Grid & Battery)			
	 Slow Blinking	Startup		Frequency synchronization	
Orange	 Solid ON	Power by DC (Battery)	Battery Low voltage (42~48V)	Grid AC low Voltage (< 200V)	Load 60~110%
	 Fast Blinking		Battery High voltage alarm (Default > 66V)	Grid AC high voltage alarm (< 255V)	Over load alarm (>110%)
	 Slow Blinking	Remote off	Battery Low voltage alarm (Default < 42V)	Grid AC low voltage alarm (< 180V)	
Red	 Solid ON	Module failure			Over load protection
	 Fast Blinking	Different system output voltage	Battery over voltage (Default >68V)	Over voltage (Default >265V)	
	 Slow Blinking	Different system frequency (50/60Hz)	Battery under voltage (Default <36V)	Under voltage (Default <150V)	
	 Intermittent Blinking	Temp. protection		Abnormal Frequency	
	 Intermittent Blinking	Fan failure			

Table 5. LED indicator

3-1-2. Green Terminal Introduction ③⑧⑨

There are three green terminals at the rear side, please refer to following figure :

Terminal	Description
Jumper A & B	Single shelf / Parallel connection setting
CN3 Dry contact and remote	Remote setting, and dry contacts

Table 7. SR-1600 green terminal introduction

3-1-2-1. Jumper A & B ③⑧



Figure 8. Jumper A & B

Pin	Function	Wiring	Status description
1	Terminal Resistor	Pin#1 and Pin#2 short/open	Short :
2			1. Signal shelf setting ^{*Note} 2. Parallel connection setting at first and last shelf (terminal shelf) Open : Parallel connection : non-terminal shelf (Refer to 3-2-2.)

Table 8. SR-1600 jumper A & B status description

* Note : Jumper A pin1 & pin2 must be shorted and Jumper B pin1 & pin2 must be shorted.

3-1-2-2. Dry contact and remote ⑨

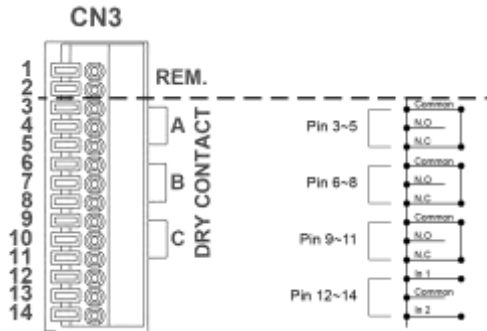

Figure 9. CN3 dry contact pin assignment

Pin	Function	Wiring	Status Description
Pin 1~2	Remote ON/OFF	Pin#1 and pin #2 short/open	Open : Normal output Short : Stop output
Pin 3~5	Major alarm	Switching power 60W Rating 2A at 30VDC wire size 20~24AWG	Normal : N.C-Common short Action : N.O-Common short (Refer to Figure 9.)
Pin 6~8	Minor alarm		
Pin 9~11	Selectable extra alarm to go with Major or minor alarm by RS485/LCM		
Pin 12~13	Digital signal input for Major alarm	Signal voltage : 5V wire size 20~24AWG	High : +5V Action Low : 0V Normal
Pin 13~14	Digital signal input for Minor alarm		

Table 9. SR-1600 CN3 status description

Alarm	Description	Possible Cause
Major alarm	Over system capacity	The system over the rated capacity
	CANBUS communication abnormal	Connect not very well
	Parameters error	Plug in the different type product
	Main source failure	AC source failure
	Digital input abnormal	Pin 12~13 voltage keep high
Minor alarm	Lost redundancy	Remove the redundancy module or redundant module failure
	Second source failure	Battery voltage abnormal
	Others alarm	Refer to alarm LED indicator (refer to page 10)

Table 10. Alarm list for dry contact

3-1-2-3. Single Shelf Setting

1. Please short the Jumper A pin#1 and pin#2.
2. Please short the Jumper B pin#1 and pin#2.

3-1-3. AC Input / Output Terminal ④ ⑦

3-1-3-1. AC Input Terminal ④

SR-1600 provides the AC utility input terminal at the rear side, and user can connect the AC cable at L / N / FG. The SR-1600 support the AC input side internal parallel connection.

3-1-3-2. AC Output Terminal ⑦

The AC output terminal at the rear side of the SR-1600. User can connect the L / N / FG.

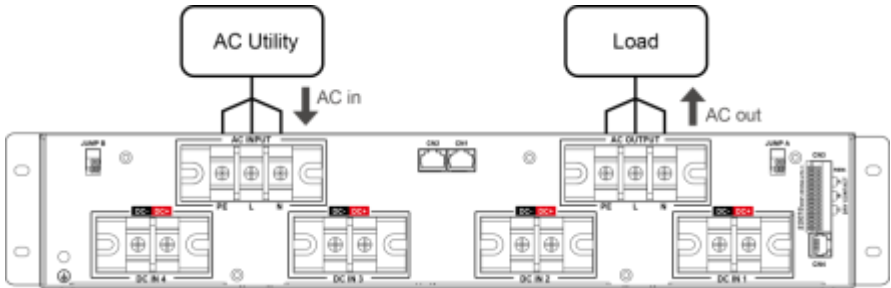

Figure 10. AC terminal connection

3-1-3-3. Cabling

Interface		Wire Color	Wire AWG
AC Input	Line (L)	Black	Breaker suggestion 200-240Vac : 50A/Shelf/8AWG 100-120Vac : 80A/Shelf/6AWG
	Neutral (N)	White	
AC Output	Line (L)	Black	
	Neutral (N)	White	
Ground		Green-Yellow	6 ~16AWG

Table 11. AC cabling definition

3-1-4. Parallel Connection Port ⑤ ⑥

In case the user needs more than 1 shelf, please use the CN1 and CN2 port to connect multi-shelves. Ensure that user sets the terminal resistor first (please refer to section 3-2).

Please use RJ-45 cable for connection. To have better performance, we

suggest the cable length is less than 100cm.



Figure 11. RJ-45 cable

#Pin	CN 1	CN 2
1	CAN_H	CAN_H
2	CAN_L	CAN_L
3	Reserved	Reserved
4	Reserved	Reserved
5	Reserved	Reserved
6	Reserved	Reserved
7	GND	GND
8	5V	5V

Table 12. RJ-45 pin assignment

3-1-5. Battery Cabling ⑪⑫⑬⑭

Connect the 24V/48V battery [+] / [-] to the SR-1600 [DC+] / [DC-]
 There are three battery input sets (DC+, DC-) on the SR-1600 rear side, and every set is independent. In case the user needs parallel connection, please do the parallel wiring outside the SR-1600 (please refer to following wiring figure).

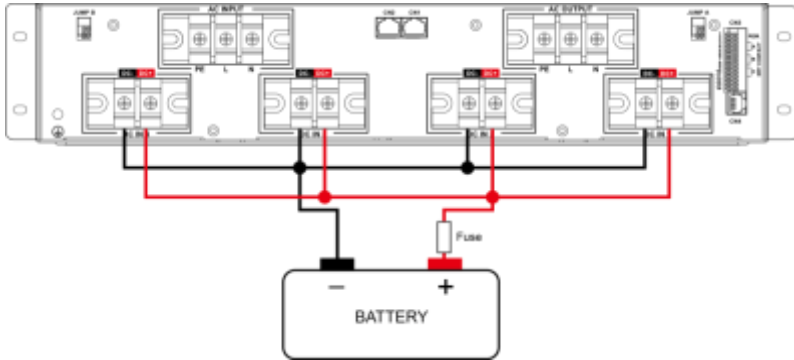

Figure 12. SR-1600 battery cabling

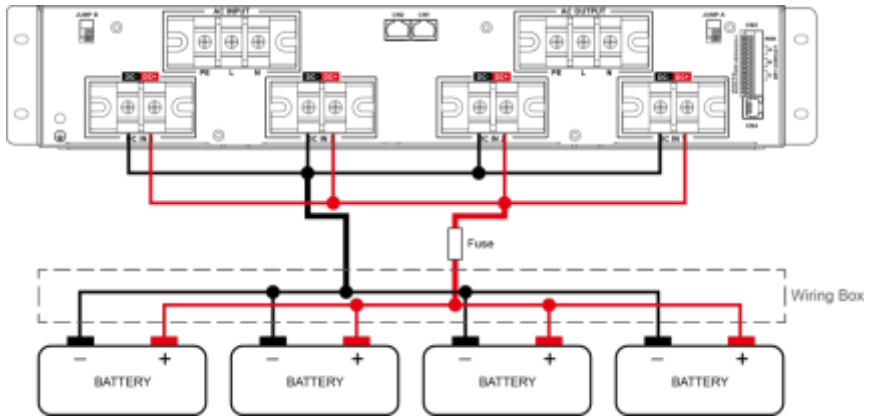

Figure 13. SR-1600 battery cabling (multi battery I)

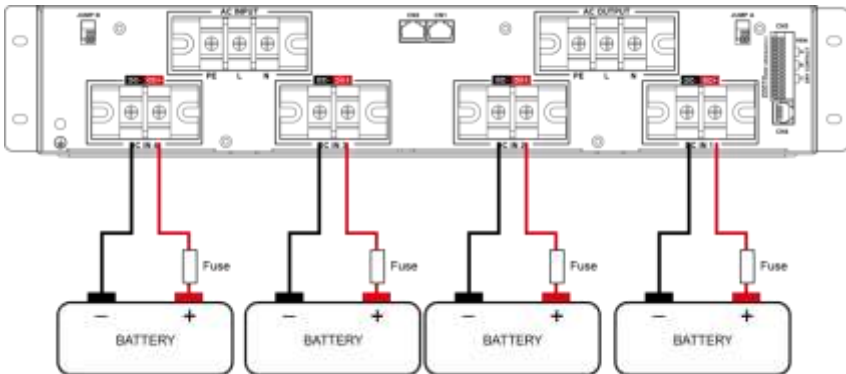

Figure 14. SR-1600 battery cabling (multi battery II)

Please refer to the suggested battery cable size.

Models	AWG	Cable diameter / per module	Fuse(slow) / per rack	Fuse(slow) / per module
SR-1600-124 / 224	#6	4 mm	400A	100A
SR-1600-148 / 248	#8	3.1 mm	300A	75A

Table 13. Cable and fuse size

3-1-6. Chassis Ground ⑮

To prevent the electric shock, please make sure the chassis ground is connected.



Warning! High current needs grounding.

3-1-7. Installation Space Requirement

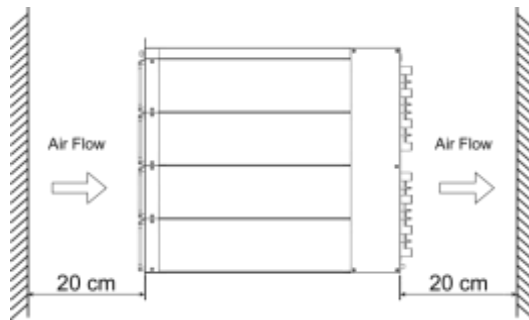

Figure 15. SR-1600 installation space requirement

Please keep 20 cm clear space for air flow at front and rear side of SR-1600.

3-1-8. RS-485 Port ⑩

RS-485 Port : Serial port monitoring and control through computer interface.



Figure 16. RS-485

SR Series		RS-485 Transfer RS-232 (HC-05)
PIN Num.	RS-485 Description	D-SUB PIN Num.
1	Not used	Not used
2	485A	2
3	485B	1
4	Not used	Not used
5	GND	GND (Optional)
6	Not used	Not used

Table 14. RS-485 cable size

3-1-8-1. RS-485 Command

Command format :

This unit uses high-level language commands with a CR (0DH) and LF (0AH) as the end of the command.

After the system executes the command unit, it sends an answer character to the PC. Under normal communication status, the answer characters are as following:

= > : The command was executed successfully

? > : Command error, not accepted

! > : Command is correct, but the implementation of the error
(such as parameters out of range)

* If the instructions are sent, do not respond to the above three symbols as an end, Please check if the PC port settings / communication line is abnormal or not.

3-1-8-2. RS-485 Command Format

Command	Function	Command	Function
POWER 1	Power on	VINV?	Show voltage of SR
POWER 0	Power off	IINV?	Show current of SR
*RST	Recovery default setting	VGRID?	Show voltage of grid
FRQ?	Show frequency of SR	VBAT?	Show voltage of battery
PINV?	Show power of SR	IGRID?	Show AC input current of SR
IBATO?	**Show DC input current	IBATI?	**Show total charge current
LOAD?	Show total power	PAUN?	Show Parallel quantity
QURY 0?	AC situation	QURY 1?	Load and battery condition
QURY 2?	Error condition	*IDN?	Factory serial number

Table 15. RS-485 command table

**Only applicable on SRC-2500

3-1-8-3. Command for Accessing Setup Menus and Adjusting Values

<Function Code>	Setting Menu	<Function Code>	Setting Menu
FUNC0	DC_OVP Setting	FUNC10	Dry contact setting
FUNC1	DC_OVP Recovery	FUNC11	*Charging voltage setting
FUNC2	DC_UVP Setting	FUNC12	*Charging current setting
FUNC3	DC_UVP Recovery	FUNC13	Assign DC to AC ratio
FUNC4	DC_UV Alarm		
FUNC5	O/P Voltage		
FUNC6	RS-485 Baudrate		
FUNC7	O/P Frequency		
FUNC8	Sync Frequency		
FUNC9	Mode Priority		

Table 16. RS-485 command table

*Only Available for SRC-2500

Example of setting:

1. Change 50Hz to 60Hz Output Frequency Operation:
Command: FUNC 7 Type
2. Query the currently set parameters: Instructions: SETT? Type
The display will show the frequency and answer characters:
50
=>
3. Change setting parameters: Command: SETT <value> Type the value you want to change,
Since this example changes the output frequency to 60, the instruction is built for SETT 60, The display will show:
=>
The delegate completes correctly

3-1-8-4. Setting Interface

1. OVP Setting <FUNC0> : Set the Over Voltage Protection (OVP) and shutdown.

Default = 34 VDC @ 24V Model. 68 VDC @ 48V Model

Model	Setting value range
24V	30 VDC ~ 34 VDC
48V	60 VDC ~ 68 VDC

Table 17. OVP setting <FUNC0>

2. OVP Recovery <FUNC1> : When the DC input voltage is higher than the OVP setting, the SR series shutdown; once the input voltage falls below the set OVP value, the SR series will automatically restart.

Default = 28 VDC @ 24V Model. 56 VDC @ 48V Model

Model	Setting value range
24V	28 VDC ~ 30 VDC
48V	52 VDC ~ 60 VDC

Table 18. OVP recovery <FUNC1>

3. UVP Setting <FUNC2> : Setting Under Voltage

Protection (UVP) and shutdown on the inverter operation.

Default= 18 VDC @ 24V Model. 36VDC @ 48V Model

Model	Setting value range
24V	18 VDC ~ 25 VDC
48V	36 VDC ~ 50 VDC

Table 19. UVP setting <FUNC2>

4. UVP Recovery <FUNC3> : When the DC input voltage is below the set UVP value, the SR series shutdown; once the input voltage rises above the set UVP value, the SR series will automatically restart.

Default= 25 VDC @ 24V Model. 50VDC @ 48V Model

Model	Setting value range
24V	23 VDC ~ 27 VDC
48V	46 VDC ~ 54 VDC

Table 20. UVP recovery <FUNC3>

5. UV Alarm <FUNC4> : Setting Under Voltage (UV) alarm. When the input voltage is lower than the set value, the SR series will sound a “beep” to remind you that the unit is going to shutdown.

Default= 21 VDC @ 24 V Model. 42 VDC @ 48 V Model

Model	Setting value range
24V	19 VDC ~ 26 VDC
48V	38 VDC ~ 54 VDC

Table 21. UV alarm <FUNC4>



Note :

The value of the voltage set for the “UV Alarm” should be equal to or higher than the value set for “UVP” or else the unit will shutdown without any audible warning.

- 6. O/P Voltage <FUNC5> : Setting the SR series output voltage on the inverter operation.

Default= 110 VAC @ 110 V Model, 230 VAC @ 230 V Model

Model	Setting value range
110V	97 VAC ~ 127 VAC
230V	194 VAC ~ 254 VAC

Table 22. O/P voltage <FUNC5>

- 7. RS-485 Baud rate <FUNC6> :

Default setting : 4800

Setting Menu	SETT<value>	
RS-485 Baud rate	0	1200
	1	2400
	2	4800
	3	9600
	4	19200

Table 23. RS-485 baud rate <FUNC6>

8. O/P Frequency <FUNC7> : Setting the SR series output frequency on the inverter operation.

Default= 60 Hz @ 110 V Model, 50 Hz @ 230 V Model.

Model	Setting value range
110V	47 Hz ~ 63 Hz
230V	47 Hz ~ 63 Hz

Table 24. O/P frequency <FUNC7>

9. Sync Frequency <FUNC8> : Setting SR series output frequency tolerance range on the inverter operation.

Default= 3

Model	Setting value range
110V	0 Hz ~ 3 Hz
230V	0 Hz ~ 3 Hz

Table 25. Sync frequency <FUNC8>

10. Mode Priority <FUNC9> : Default =1, AC Mode is the 1st priority source.

DC Mode : DC is the 1st priority source, and the AC power is the 2nd priority source.

AC Mode : AC is the 1st priority source, and the DC power is the 2nd priority source.

Mode Priority	SETT<value>
DC Mode	0
AC Mode	1

Table 26. Mode priority <FUNC9>

11. Dry contact C setting <FUNC10> : Default =1, Setting range = 0~2, default=1.

Setting Menu	SETT<value>	
Dry contact C setting	0	Disable
	1	Follow dry contact A (major alarm)
	2	Follow dry contact B (minor alarm)

Table 27. Dry contact setting <FUNC10>

12.*Charging voltage setting <FUNC11> : Default =54 VDC

Model	Setting value range
48V	52 VDC ~ 58 VDC

Table 28. Charging voltage setting <FUNC11>

13.*Charging current setting <FUNC12> : Default =0 A

Model	Setting value range
48V	0A~25A

Table 29. Charging current setting <FUNC12>

*Only Available for SRC-2500

14 Assign DC and AC ratio <FUNC13> : Setting range = 10, 20, 30, 40, 50, 60, 70, 80, 90, 100 **Default= 100 (Disable)**

Setting Menu	SETT<value>	Description
AC Ratio	10	AC load 10%, DC load 90%
	20	AC load 20%, DC load 80%
	30	AC load 30%, DC load 70%
	40	AC load 40%, DC load 60%
	50	AC load 50%, DC load 50%
	60	AC load 60%, DC load 40%
	70	AC load 70%, DC load 30%
	80	AC load 80%, DC load 20%
	90	AC load 90%, DC load 10%
	100	Disable

Table 30. Charging current setting <FUNC13>

3-2. Parallel Connection

3-2-1. Multi-shelves Installation

There are two parallel connection methods for the SR-1600 system capacity expansion: Setting jumper and use COTEK iC-Hub.

3-2-2. Parallel Connection with Jumper Setting

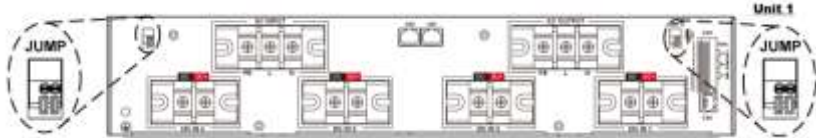

Figure 17-1. Parallel connection via jumper setting

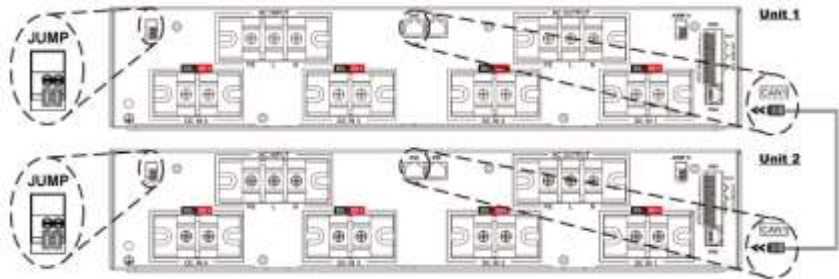

Figure 17-2. Parallel connection via jumper setting



Figure 17-3. Parallel connection via jumper setting

Green terminal JUMP connection :

Parallel connect	Unit 1	Unit 2	Unit 3
JUMP	Connected	Not connected	Connected

※ Take 3 units for example, only the first and the last unit need to connect jumper.

3-2-3. Parallel Connection with COTEK iC-Hub

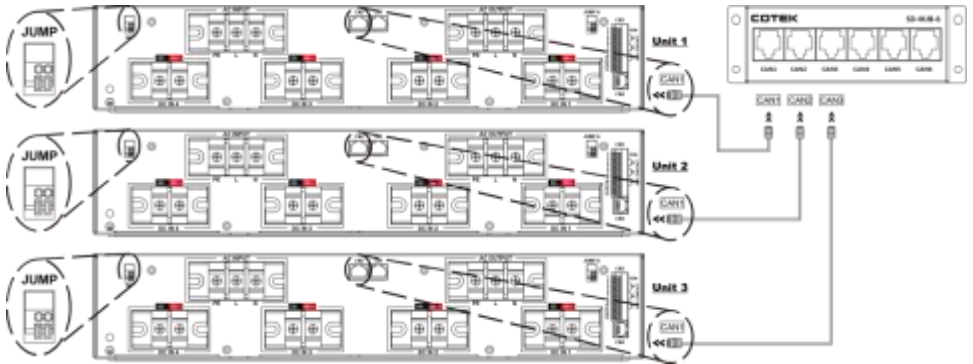

Figure 18. Parallel connection via COTEK iC-Hub

Green terminal JUMP connection :

Parallel connect	Unit 1	Unit 2	Unit 3
JUMP	Not connected	Not connected	Not connected

※ Take 3 units for example, no need to connect the jumper.

3-3. Maintenance

3-3-1. Inverter Module Replacement

3-3-1-1. Remove the inverter module

Step 1 : Pull up the SR-1600 handle

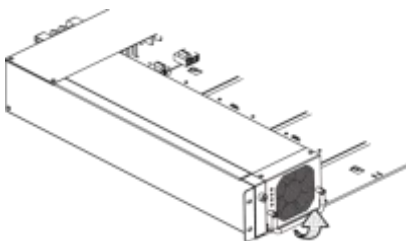

Figure 19. Remove the inverter module: step 1

Step 2 : Remove the SR-1600 out of the shelf

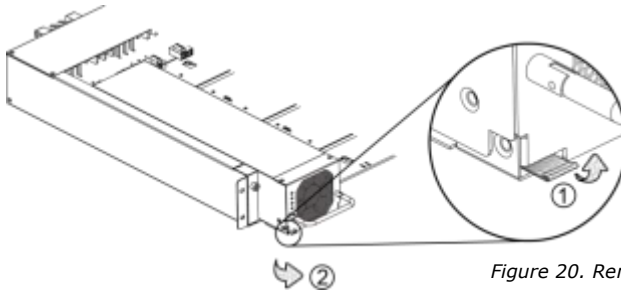

Figure 20. Remove the inverter module: step 2

3-3-1-2. Insert the inverter module

Step 1 : Insert the SR-1600 into the shelf slot

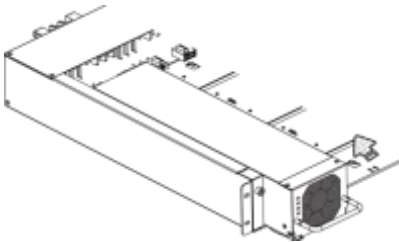

Figure 21. Insert the inverter module: step 1

Step 2 : Make sure the handle at down position

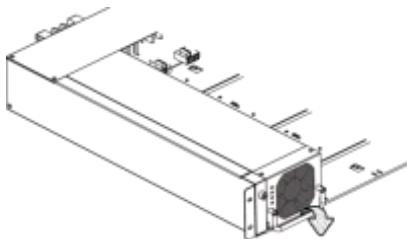

Figure 22. Insert the inverter module: step 2

3-3-2. Fan Module Replacement



Warning! Please contact technical person to replace fan module.

Step 1 : Please follow the 3-3-1-1. to remove the SR-1600 module out of shelf.

Step 2 : Use the screw driver to remove the 4 screws on the fan module (top side 2 pcs, rear side 2 pcs), and user can remove the fan module.

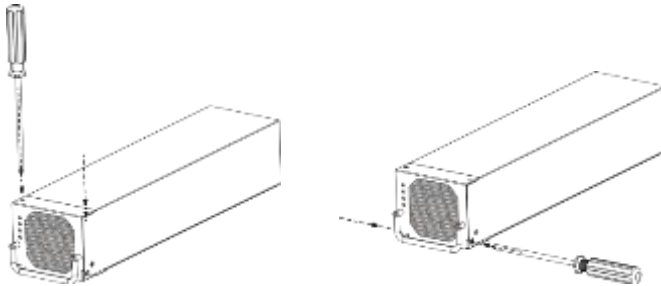

Figure 23. Fan module replacement: step 2

Step 3 : Remove 4 screws and power cord on fan

Step 4 : Replace the new fan and fix 4 screws and power cord on new fan

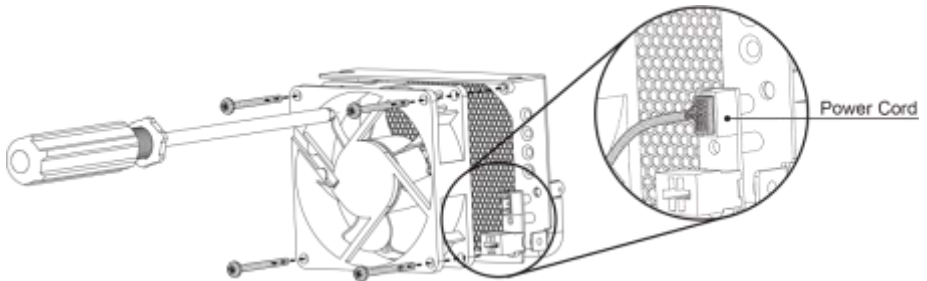

Figure 24. Fan module replacement: step 4

Step 5 : Connect the fan module into the front side of inverter and make sure PCB pin plugged into the slot

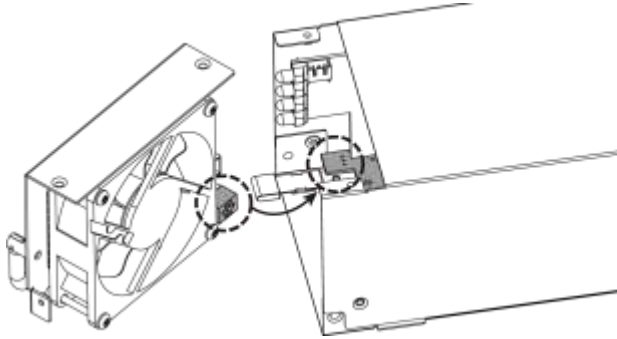

Figure 25. Fan module replacement: step 5

Step 6 : Use the screw driver to fix 4 screws on fan module.

Step 7 : Follow 3-3-1-2 to insert the inverter module.



Note :

1. Please make sure the fan power cable is connected well.
2. Suggest to clean the dust of the fan guard (every 3 months), to keep fan operating longer.

The following data shows the fan specification (power cable 50mm)

Item	Specification / Condition
Rated Voltage	12 VDC
Rated Current	285mA / Max. 328mA
Rated Power Consumption	3.4 Watts / Max. 3.94 Watts
Operating Voltage Range	6~13.8 VDC
Starting Voltage	6 VDC (25 deg. C Power On/Off)
Operating Temperature Range	-10 to +70 deg. C
Storage Temperature Range	-40 to + 70deg. C
Rated Speed	4500 RPM \pm 10% at rated voltage
Air Flow	57 CFM
Static Pressure	0.35 Inch H ₂ O
Acoustic Noise	46 dB(A)
Insulation Class	UL Class A
Insulation Resistance Plastic Housing	10M ohm at 500 VDC between internal stator and lead wire(+)
Dielectric Strength	Applied AC 500V for one minute or AC 600V for 2 seconds between housing and lead wire(+)
Life Expectancy	70,000 hours at 40 deg. C, 65% humidity, 90% CL.
Protection	Automatic Restart*

*In a situation where the fan is locked by an external force while the electricity is on, an increase in coil temperature will be prevented by temporarily turning off the electrical power to the motor. The fan will automatically restart when the locked rotor condition is released.

Table 31. SR-1600 fan specification



Caution! Using fans that do not meet above specification will void warranty.

4. Trouble shooting









LED status	Possible Description	Solution
 LED red intermittent blinking --- --	Over temperature protection (OTP)	1. Make sure the installation space 2. Check the fan and clean the fan filter 3. Reduce the environment temperature 4. Reduce the load
 LED red fast blinking ■■■■■■	Different output voltage module in the same rack	1. Confirm system output voltage 2. Remove abnormal module 3. Confirm module type
 LED red slow blinking --- --	Module frequency mismatch	1. Confirm system frequency 2. Use RS-485 to set the frequency
 LED red fast blinking ■■■■■■	Input over voltage protection (OVP)	1. Check input voltage 2. Reduce the input voltage
 LED red slow blinking --- --	Input under voltage protection (UVP)	1. Battery deep discharge: please charge the battery 2. Please check the battery connection A. Cable diameter B. Tighten the connector
 LED red intermittent blinking --- --	AC frequency not synchronization	1. Check the AC source frequency 2. Check the SR-1600 frequency setting
 LED red slow blinking --- --	Under AC voltage	Check the AC source voltage
 LED red solid on _____	Short / Over load	1. Check the connection and make sure the cable is not short 2. Reduce the load

Table 32. Trouble shooting

5. Warranty



Warning! Do not open or disassemble the Inverter. Attempting to do so may cause risk of electrical shock or fire.

We guarantee this product against defects in materials and workmanship for a period of 24 months from the date of purchase. In case you need to repair or replace any defective power inverters, please contact COTEK local distributor.

This warranty will be considered void if the unit has been misused, altered, or accidentally damaged. COTEK is not liable for anything that occurs as a result of the user's fault.

6. Appendix

6-1. UART ASCII code Communication Description :

<INTR> --> Integer.

<ECHO> --> Echo data from Inverter, Integer, Hex code or Real numbers.

END Code (ENTER) = 0x0d (CR) + 0x0a (LF)

6-2. Baud rate/Parity/Data length/Stop bit :

Default 9600/N/8/1

6-3. COMMAND

A. AC Status Query :

“QURY 0?” + 0x0d + 0x0a

<ECHO1> + <ECHO2> + 0x0d + 0x0a

<ECHO1> = xH = abcdB

<ECHO2> = yH = efghB

Bit a Frequency phase OK flag

Bit b AC/DC mode status flag (0 : DC mode 1 : AC mode)

Bit c Reserve

Bit d MCU POWER fault flag

Bit e Occur Soft Reset flag

Bit f Inverter Damage flag

Bit g AC Grid Voltage OK flag

Bit h Reserve

* Example: Reply to C2 (1100 0010) is AC frequency with normal frequency voltage

B. LOAD & BATTERY Level Query :

“QURY 1?” + 0x0d + 0x0a

<ECHO1> + <ECHO2> + 0x0d + 0x0a

<ECHO1> = xH = Load Level : B=110%~119%、A=100%~109%、…、
5=50%~59%、…、0=0%~9%

<ECHO2> = yH = battery Level : ((Battery Voltage/n) - 10.3)/0.36
(12V system n=1 ; 24V system n=2 ; 48V system n=4)

* Example: Response 56, the load is 5 = 50% ~ 59%; battery is n = 6 after about 49.8V

C. Inverter Status Query :

“QURY 2?” + 0x0d + 0x0a

<ECHO1> + <ECHO2> + 0x0d + 0x0a

<ECHO1> = xH = abcdB

<ECHO2> = yH = efghB

Bit a OLA occur flag

Bit b OVA occur flag

Bit c UVA occur flag

Bit d OTP occur flag

Bit e Reserve

Bit f OLP occur flag

Bit g OVP occur flag

Bit h UVP occur flag

* Example: Reply 20 (0010 0000) is UVA

COTEK

COTEK

No.33, Sec. 2, Renhe Rd., Daxi Dist., Taoyuan City 33548, Taiwan

Phone : +886-3-3891999 FAX : +886-3-3802333

[http : // www.cotek.com.tw](http://www.cotek.com.tw)

2017.01._A0