

Planning an Enphase Ensemble Energy Management Technology System

Table of Contents

Planning an Enphase Ensemble Energy Management Technology System	1
Overview.....	2
Ensemble Technology System Overview.....	2
Ensemble Technology Systems Common Configurations	3
Backup Configurations.....	3
Non-backup Configuration - Installing Ensemble without Enpower.....	8
Use Cases and Sizing	9
Load Analysis.....	9
Backup Use Case	9
IQ Microinverter PV System to Encharge Pairing.....	10
M-Series Microinverter PV System to Encharge Pairing	10
Self-Consumption Use Case	11
Economic Use Cases.....	11
Smart Profiles	11
Ensemble Products	12
Enpower Smart Switch.....	12
Encharge Storage System	14
IQ Combiner or IQ Envoy standalone For IQ-Series Microinverters	14
Envoy-S Metered For M-Series Microinverters	15
Ensemble Communications Kit.....	15
M-Series Microinverters Replacements.....	16
Component List.....	16
Key Planning Considerations	19
Physical Installation Considerations	19
Temperature Considerations.....	20
Electrical Installation Requirements.....	20
Voltage Regulation Considerations.....	21
Rapid Shutdown Considerations	21
Glossary	22
Appendix A – Single line diagrams for IQ-Series systems	23
Whole home backup configuration	23
Partial home backup configuration	24
Partial home backup configuration, split system with additional consumption CTs.....	25
Partial home backup configuration, split system with NO additional consumption CTs	26
Encharge only configuration	27
Appendix B – Single line diagrams for M-Series systems	28
Whole home backup configuration	28
Partial home backup configuration	29
Partial home backup configuration, split system with NO additional consumption CTs	30
Encharge only configuration	31

Overview

This document provides site surveyors and design engineers with the information required to evaluate a site and plan the installation of the Enphase Ensemble™ energy management technology system. The information provided in this document supplements the information in the data sheets, quick install guides, and product manuals. Diagrams and information in this document are illustrative of example system configurations and installations. However, they may not include all requirements from additional local codes and standards and Authorities Having Jurisdiction (AHJs) applicable to a site.

Note: This guide describes an Ensemble system with IQ-Series or M-Series microinverters. Please pay particular attention to the equipment requirement for each type of microinverter.

Ensemble Technology System Overview

With Ensemble technology, homeowners have power when the grid goes down and can save money when the grid is up. Ensemble technology systems include the following Enphase products:

- **Enphase Encharge™ storage system** is an all-in-one AC coupled storage system that includes embedded, grid-forming multimode microinverters. You can connect multiple Encharge storage systems to maximize potential backup for homes. The Encharge 3 storage system provides flexibility to customers to start small and add capacity incrementally.
- **Enphase Enpower™ smart switch** connects the home to grid power, the Encharge storage system, and PV. It provides microgrid interconnect device (MID) functionality by automatically detecting and seamlessly transitioning the system from grid power to backup power in the event of a grid failure. It allows Encharge storage systems to form an intentional island (per IEEE 1547.4 definition) and contains a neutral-forming transformer (NFT) to enable 120/240 V operation in backup mode.
- **Enphase Wireless communication kit** enables direct communication between Encharge, Enpower, and the Envoy using 2.4 GHz frequency. The kit is connected to one of the USB ports on the Envoy.
- An **Enphase Mobile Connect™** cellular modem is required unless already present to ensure the best performance of your system. The cellular modem connects to a USB port on the Envoy.
- **For new or retrofit systems with IQ-Series solar microinverters:**
 - **IQ 6™ / IQ 7™ series microinverters and accessories.** Ensemble technology is fully compatible with IQ 7 and IQ 6 series microinverters and makes retrofit upgrades as simple as new installations.
 - **IQ Envoy™**, a communications gateway that can communicate with M-Series inverters, Encharge batteries, and the Enpower smart switch. It collects system performance information and transmits that information over the internet to Enphase's Enlighten cloud. An IQ Envoy is required for Ensemble systems with IQ-Series microinverters. Note the IQ Envoy is included in an Enphase IQ Combiner. For retrofit sites, an IQ Envoy may already be present.
 - **IQ™ Combiner series** consolidates interconnection equipment into a single enclosure and streamlines PV and storage installations by providing a consistent, pre-wired solution for residential applications. It includes the Enphase **IQ Envoy**. Install the new communication kit in any IQ Combiner to enable wireless communication with Encharge and Enpower.
- **For retrofit systems with M-Series solar microinverters:**
 - **Enphase M-Series microinverters and accessories.** Ensemble technology is compatible with Enphase M215 and M250 microinverters and makes retrofit upgrades simple.
Note: The Ensemble upgrade is only compatible with **M215** and **M250** series microinverters. Other legacy microinverters are not supported.
 - An **Envoy-S Metered** is required. It is a communications gateway that can communicate with M-Series inverters, Encharge batteries and the Enpower smart switch. It collects system performance information and transmits that information over the internet to Enphase's Enlighten cloud. An Envoy-S Metered is required for every Ensemble system with M-Series microinverters.
Note: Legacy Envoy/EMU SKUs (ENV-120-01 or ENV-120-02, IEMU-03 or IEMU-01 or IEMU02) will not work with an Ensemble system. You must replace these legacy SKUs with an Envoy-S Metered during the Ensemble installation.

Note: The IQ Envoy will not communicate with M-Series microinverters and M-Series microinverters will not communicate with the IQ Envoy.

- **Enphase Consumption CTs** enable home energy consumption monitoring and are required for Ensemble to operate correctly.

Ensemble Technology Systems Common Configurations

Regulatory Background – National Electrical Code

Grid-tied only PV inverters are required to shut down in the event of a utility grid power outage. They cannot form an un-intentional island, and their anti-islanding technology prevents the formation unintentional islands. Ensemble technology systems could provide backup to some or all of the load circuits in a home by forming an intentional island according to 2017 NEC sections 690 and 705. The Enpower smart switch with MID function in conjunction with the multimode inverters in the Encharge energy storage system comprise a microgrid system that forms an intentional island entirely within the bounds of the local electric power system (EPS). Figure 1 below shows a drawing of an AC coupled multimode system based on 2017 NEC section 690 and 705.

Figure 1: Microgrid system components based on 2017 NEC 690 and 705

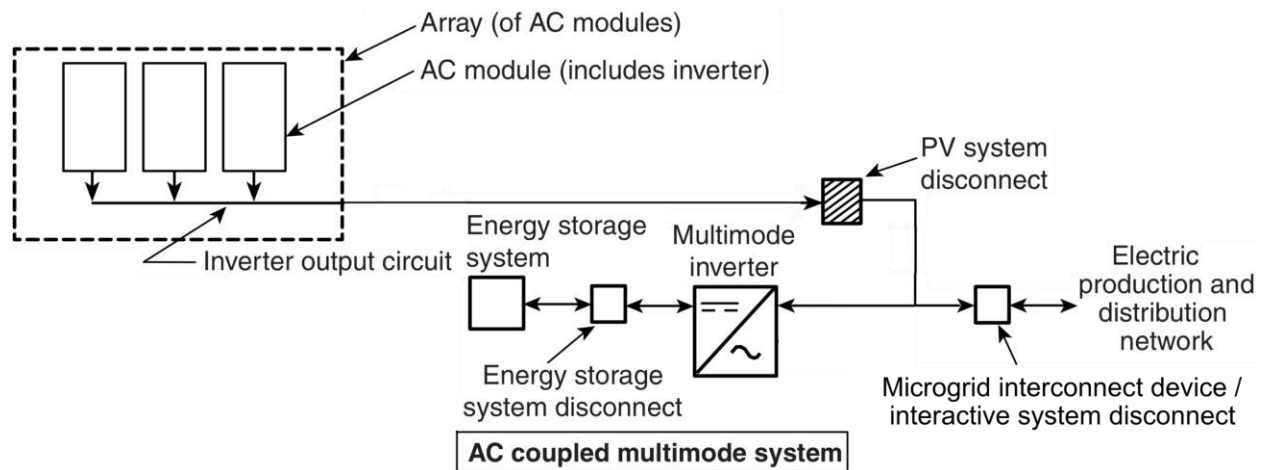

Backup Configurations

Ensemble technology system flexibility enables many backup configurations for different customer goals and needs. There are two common configurations that allow the Encharge storage system to provide power to customer loads independent of the grid.

Whole-home Backup – Enpower Installed on the Line-Side of the Main Load Panel

In the whole home (main load panel) backup configuration, Enpower smart switch is installed on the line-side of the main load panels rated up to 200A. This allows a properly sized Ensemble technology system to provide power to all loads in the main load panel in the event of a grid outage. In this configuration, the Enpower smart switch can be configured with a main breaker to act as the service disconnecting means. The PV system can be interconnected to the Enpower smart switch on a dedicated breaker or may be interconnected to the main load panel. This configuration typically supports larger PV and storage system sizes and may allow avoiding expensive utility service and/or main service panel upgrades. Examples of this whole-home (main load panel) backup configuration are shown in Figure 2 for IQ-Series microinverters based systems and Figure 3 for M-Series microinverters based systems.

Figure 2: Always-On Ensemble technology system with whole-home (main load panel) backup for IQ-Series PV microinverters. The Enpower smart switch is installed on the line-side of the main load panel, and PV and Encharge storage system are interconnected into the Enpower smart switch.

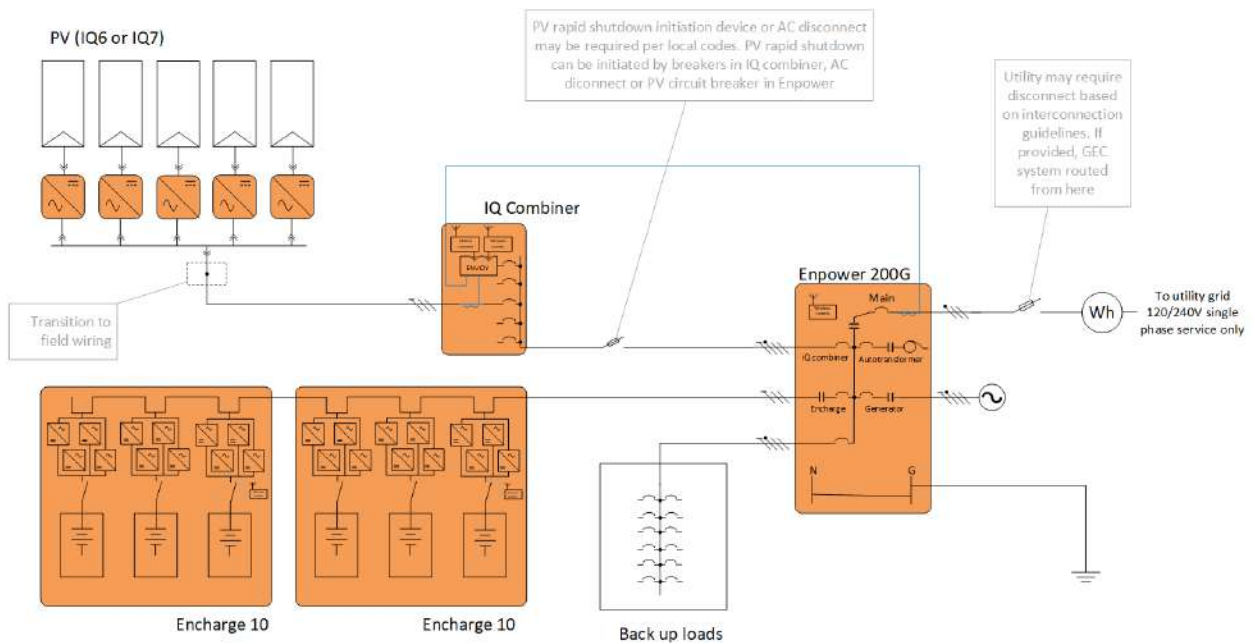
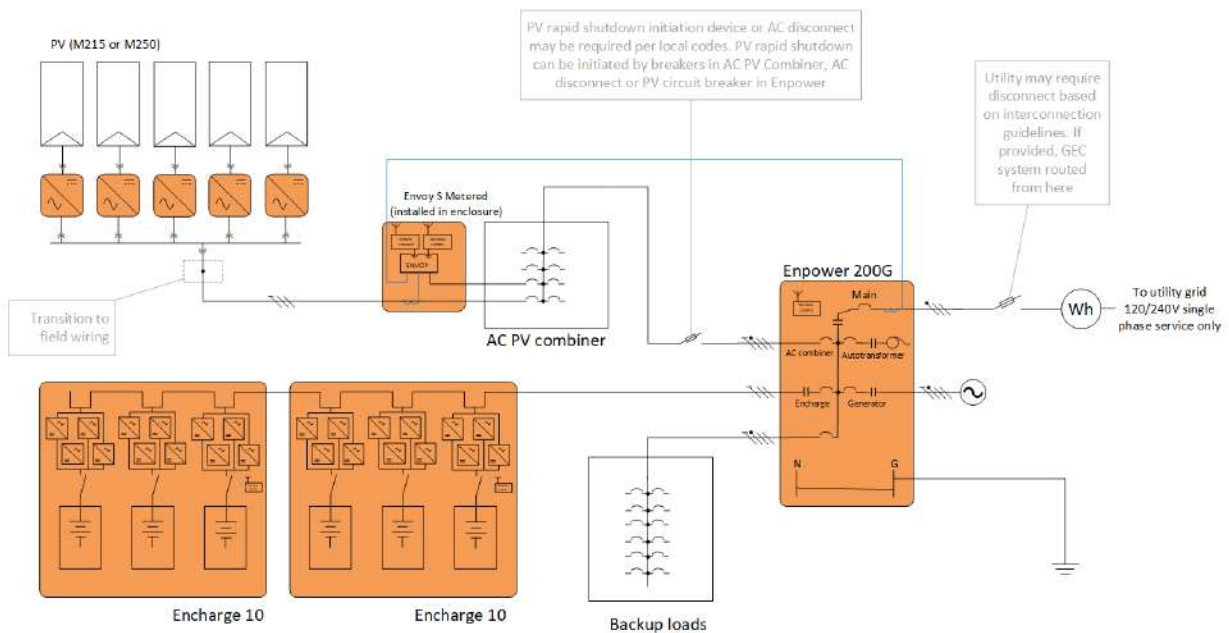

Figure 3: Always-On Ensemble technology system with whole-home (main load panel) backup for M-Series PV microinverters. The Enpower smart switch is installed on the line-side of the main load panel, and PV and Encharge storage system are interconnected into the Enpower smart switch.



Partial Home (Subpanel) Backup – Enpower Smart Switch and a Backup Subpanel Installed on the Load Side of the Main Load Panel

The Enpower smart switch can also be installed on the load side of the existing main load panel or service equipment. This configuration can be used when the Ensemble technology system is configured to provide backup to a number of pre-selected load circuits. This configuration is recommended when Encharge storage systems with smaller energy and power capacity and some basic load backup is desired by the customer, or when existing constraints prevent main panel backup or other installation methods. Figure 4 below shows an example of a partial home (subpanel) backup configuration for an IQ-Series microinverters based system while Figure 5 shows the same for M-Series microinverter based system.

Figure 4: Always-On Ensemble technology system with partial home (subpanel) backup for IQ-Series microinverters. Enpower is installed on the load side of the main load panel with select loads backed up in a backup subpanel.

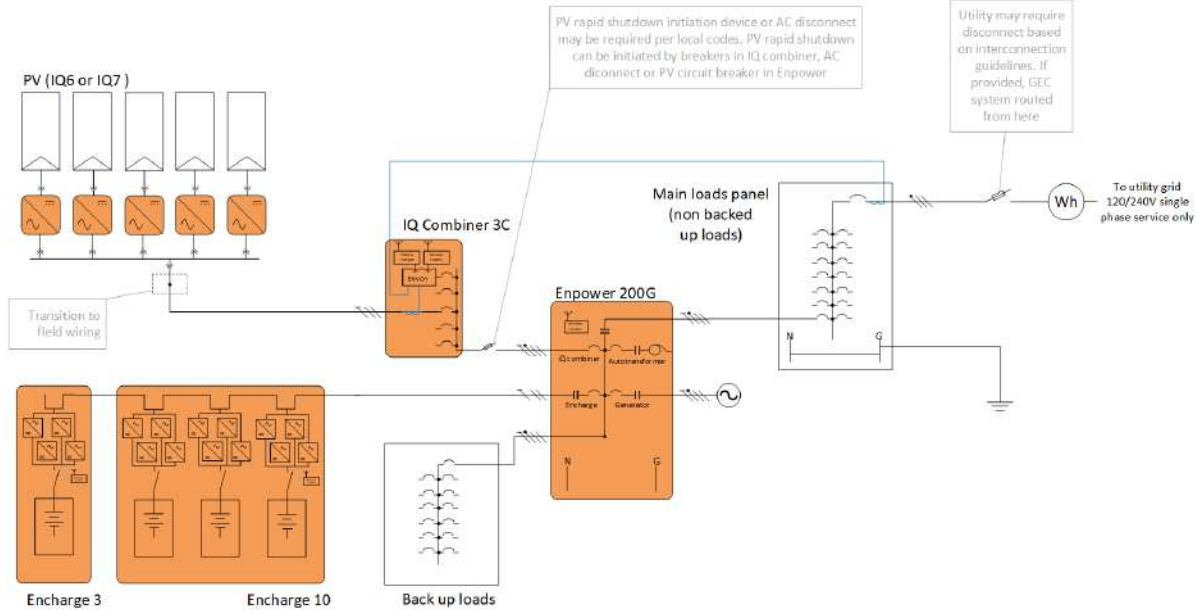
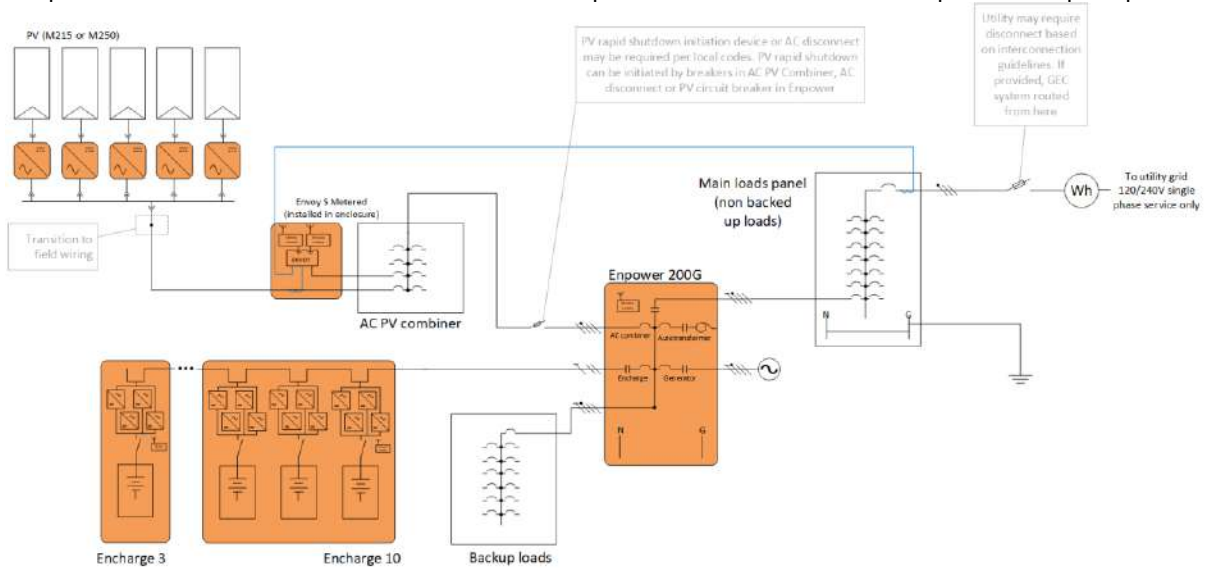

Figure 5: Always-On Ensemble technology system with partial home (subpanel) backup for M-Series microinverters. Enpower is installed on the load side of the main load panel with select loads backed up in a backup subpanel.



Split Enphase Systems on a Single Site

If the total PV system size exceeds what can be supported by the total Encharge system size, it is necessary to “split” the PV systems into a microgrid, and a non-microgrid PV system, each with their own Envoy. For guidance PV system size pairing with an Encharge system, see the sections: *IQ Microinverter PV System to Encharge Pairing* and *M-Series Microinverter PV System to Encharge Pairing*

This configuration does not support power export limiting.

The following items are needed to create a split system.

1. Two Envoys:
 - Multiple Envoys are required for split systems, because the microgrid and non-microgrid PV microinverters operate with different grid profiles and parameters.
2. Installation of a power line filter:
 - When multiple Envoys exist on site, a power line filter must be installed to prevent cross domain communication.
 - The [Q-LCF-064-1P](#) is a tested solution that is compatible with Enphase IQ6/7 microinverters and IQ Envoy at up to 64A of continuous current.
 - Similarly, the [RP220](#), [RP225](#), [RP230](#), or [RP240](#) series from Radius Power can be used with M215/M250 microinverters and the Envoy-S Metered.
 - Enphase recommends installing the power line filter with the microgrid Envoy and all microgrid PV microinverters on the “Load” input of the filter and the Enpower source on the “Line” input of the filter. (See figures below.)
3. Installation of additional Consumption CTs:
 - Depending on the configuration of the split system, an additional pair of Consumption CTs may need to be added. See the following for details.

Split systems that DO require additional Consumption CTs

If the non-microgrid PV system is interconnected on the load side of the primary microgrid Envoy’s Consumption CT, a second set of Consumption CTs must be added around the non-microgrid PV conductors and connected in parallel with the primary microgrid Consumption CT wiring to the microgrid Envoy. Please refer to Figure 6 and Figure 7 for more details and the orientation of the CTs.

Figure 6: “Split” PV system that requires an additional set of Consumption CTs

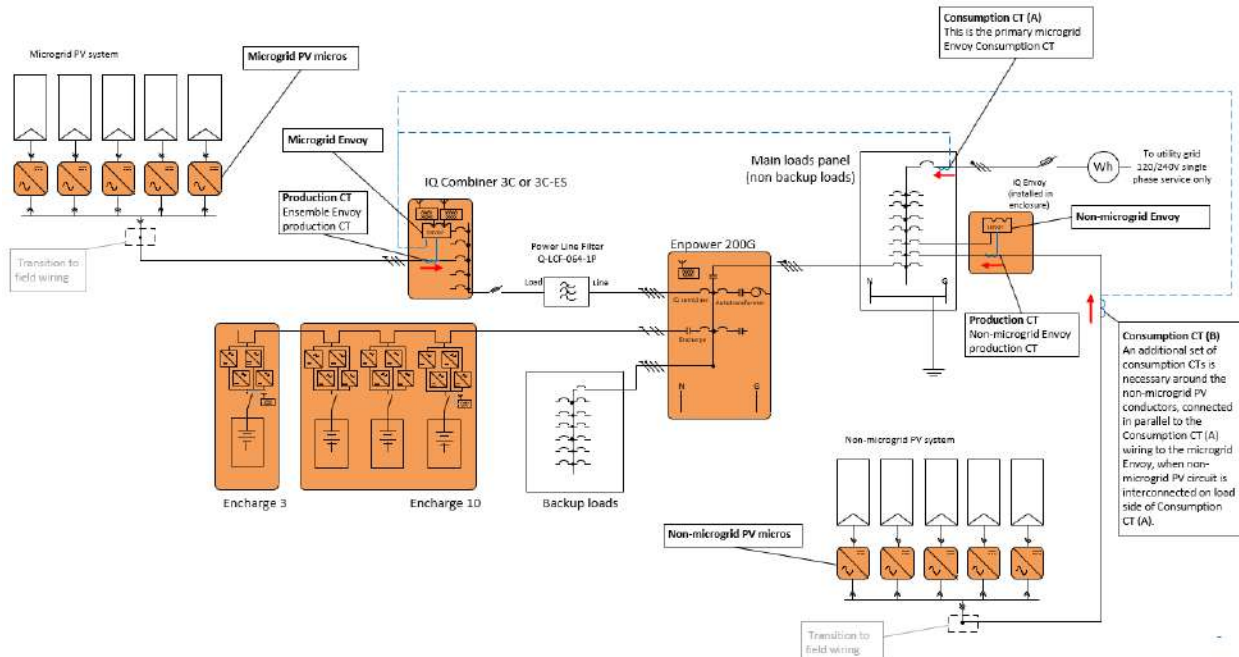

Split systems that do NOT require additional Consumption CTs

For systems where the non-microgrid PV system is interconnected on the utility side of the primary microgrid Envoy's Consumption CTs, NO additional Consumption CTs are needed. See Figure 7 for this configuration.

Figure 7: "Split" PV system that does NOT require an additional set of Consumption CTs

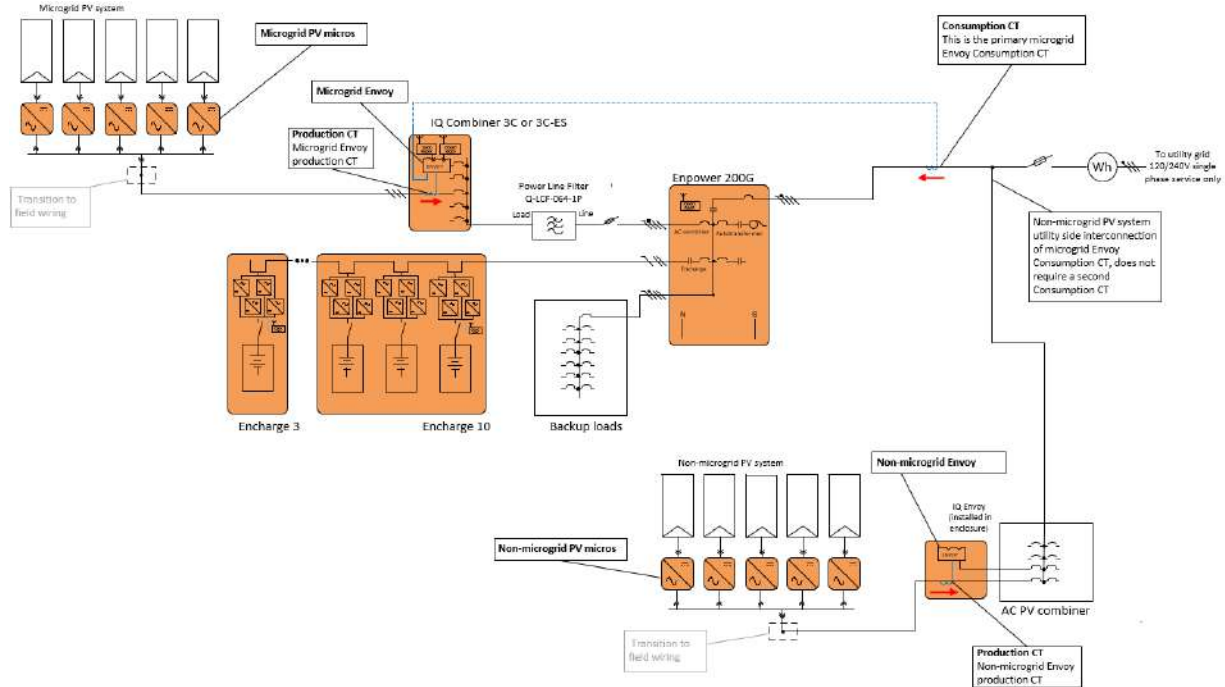

M-Series microinverter systems support similar configurations for "split" PV systems. An example where non-microgrid PV system is interconnected on the utility side of the microgrid Envoy's Consumption CTs is shown below. No additional consumption CTs are needed.

Figure 8: M-Series "split" PV system that does NOT require an additional set of Consumption CTs

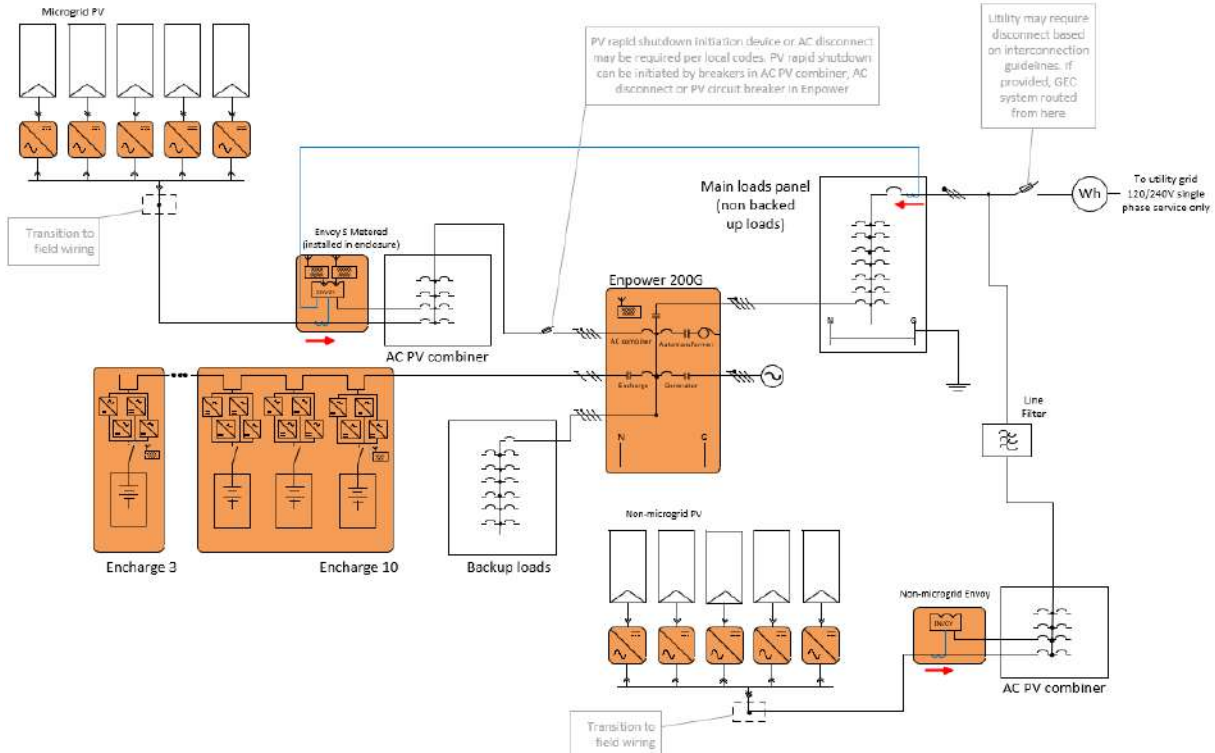

Non-backup Configuration - Installing Ensemble without Enpower

The Encharge storage system can be added to an existing system without using an Enpower smart switch, however, it will not provide backup power. When installed in this configuration, the Encharge storage system is treated as a distributed energy resource (DER), equivalent to a PV system, and cannot form an intentional island. It may be connected in the IQ Combiner or on a user-provided distribution point in compliance with the NEC. Ensure that the consumption CTs are installed on the line-side of Encharge storage system interconnection point and that Encharge storage system circuits are not included in the production CT. Figure 9 and Figure 10 show this configuration for IQ6/7 and M215/250 microinverters, respectively.

Figure 9: Grid interactive Encharge storage system installation with no backup on IQ6/7 microinverter sites

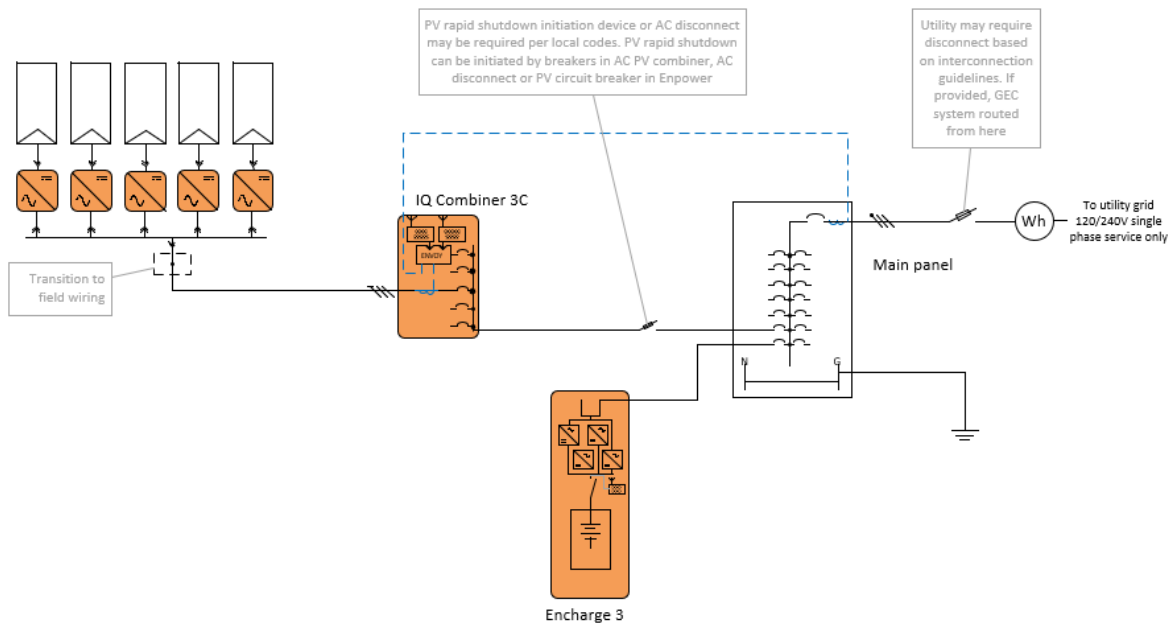
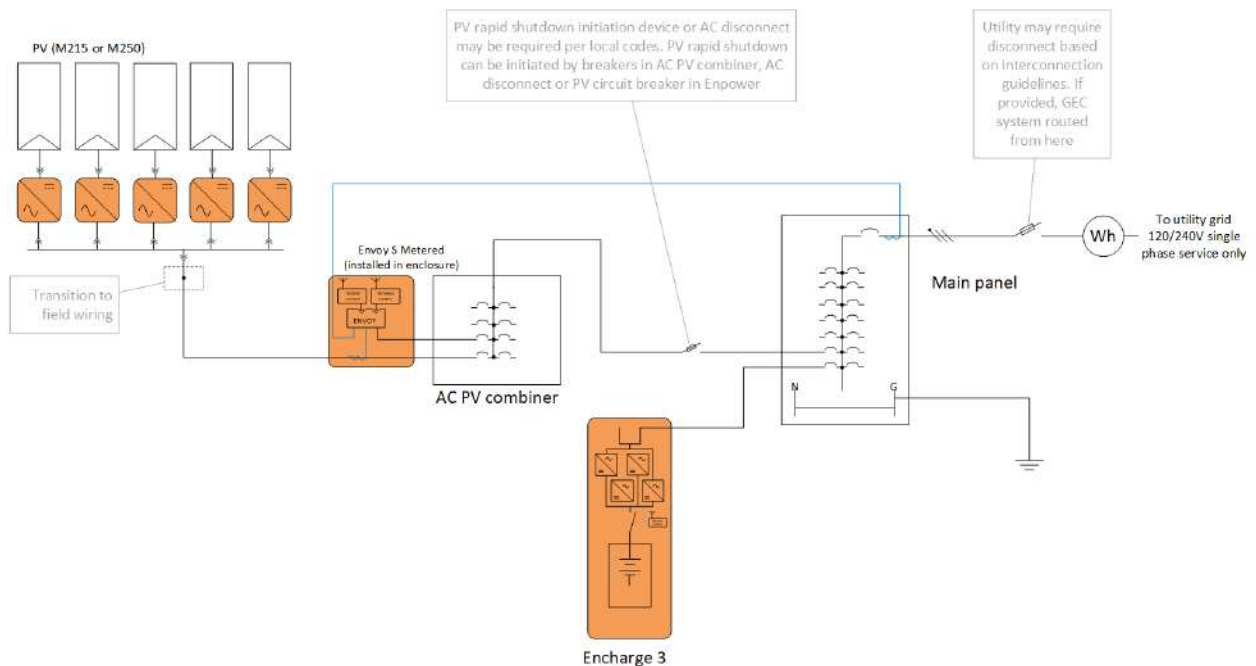

Figure 10: Grid interactive Encharge storage system installation with no backup on M-Series microinverter sites



Use Cases and Sizing

Load Analysis

The first step in correctly sizing a system is a proper load analysis. If an Envoy with correctly configured consumption CTs is already installed at a site, you can use data from Enlighten to properly size the system. A site survey, electric bills, and third-party consumption meters can also provide useful load data for system sizing. Also, review the *Enphase Ensemble Project Survey* document and System Estimator at estimator.enphaseenergy.com.

Backup Use Case

A backup system provides power to loads when the grid is down.

It is important to differentiate the terms **power** and **energy**. **Power** is a measure of the instantaneous electricity used and is expressed in units of watts (W) or kilowatts (kW). **Energy** is the accumulated or integrated power used over time and is expressed in units of watt-hours (Wh) or kilowatt-hours (kWh). When running in the backup operation, any power capacity shortages or energy capacity shortages will result in a loss of power to loads and should be avoided. Therefore, it is important to properly size the system for both power and energy capacities in each installation.

Sufficiently size the total Encharge storage system **power** rating to **power** loads and charge from PV power generation. You can increase the power rating by adding additional Encharge storage units, which also provide additional energy, improving the customer user experience.

- **Power** (kW) capacity from Encharge storage system *must* exceed the maximum single load. Total IQ 6 or IQ 7 series microinverters AC power rating connected to the microgrid may not exceed 150% of the total Encharge continuous power rating (Table 1).
 - **2017 NEC 690.10 -> 710.15 (A) Supply Output.** Power supply to premises wiring systems shall be permitted to have less capacity than the calculated load. The capacity of the stand-alone supply shall be equal to or greater than the load posed by the largest single utilization equipment connected to the system. Calculated general lighting loads shall not be considered as a single load.
- **Energy** storage (kWh) capacity should be sized to supply to the estimated backup loads for a user-defined period.

Sizing Encharge Storage System for Whole-home (Main Panel) Backup

For **whole-home backup**, when an Enpower smart switch is installed on the line-side of the main load panel, at minimum, the greater of a) two Encharge 10 units or b) number of Encharge 3 units to meet the IQ Microinverter PV System to Encharge Pairing (see below), is recommended.

Sizing Encharge Storage System for Partial Home (Subpanel) Backup

For **partial home backup**, when an Enpower smart switch is installed on the load side of the main load panel follow these steps to size an Encharge storage system:

1. Identify the largest maximum single load power rating (kW) that you want to backup, and select the absolute minimum number of Encharge units required to meet the 2017 NEC 690.10->710.15(A) requirements.
2. Calculate the total PV system maximum continuous output power of all IQ 6 / IQ 7 series microinverters in the system. Then select the minimum number of Encharge storage units required so that the total PV system output AC power is not greater than 150% of the total Encharge storage system power capacity.
3. Based on the estimated backup loads for the user-defined period, calculate the required Encharge energy storage (kWh) capacity and the minimum number of Encharge required.
4. Based on a site's load analysis of both power (kW) and energy capacity (kWh) needed, determine the total number of Encharge units required for the storage system.
 - a. The minimum number of Encharge 3 units required is the largest of the calculated values in steps 1 and 2.
 - b. The desired number of Encharge storage system units is the value calculated in step 3.
 - c. The maximum allowed number of Encharge 3 units that can be connected to a single Enpower smart switch is 12 (four Encharge 10).

IQ Microinverter PV System to Encharge Pairing

The following table identifies the maximum number of microinverters that can be connected to a given Encharge storage system size. Maximum PV system output power cannot be greater than 150% of the total Encharge storage system power capacity to ensure stable system operation.

Table 1: Maximum number of IQ microinverters for Encharge storage system for backup operation

Encharge 3 units	Equivalent Encharge 10 units	Encharge energy capacity (kWh)	Encharge power capacity (kWac)	Max PV system power (kWac)	Maximum number of microinverters					
					IQ 6	IQ 6+	IQ 7	IQ 7+	IQ 7X	IQ 7A
1		3.36	1.28	1.92	8	6	8	6	6	5
2		6.72	2.56	3.84	16	13	16	13	12	11
3	(1x Encharge 10)	10.08	3.84	5.76	25	20	24	19	18	16
4		13.44	5.12	7.68	33	27	32	26	24	22
5		16.8	6.4	9.6	41	34	40	33	30	27
6	(2 x Encharge 10)	20.16	7.68	11.52	50	41	48	39	36	33
7		23.52	8.96	13.44	58	48	56	46	42	38
8		26.88	10.24	15.36	66	54	64	52	48	44
9	(3 x Encharge 10)	30.24	11.52	17.28	75	61	72	59	54	49
10		33.6	12.8	19.2	83	68	80	66	60	54
11		36.96	14.08	21.12	91	75	88	72	67	60
12	(4 x Encharge 10)	40.32	15.36	23.04	100	82	96	79	73	66

Warning: Undersizing power and energy capacity of the storage system may lead to a poor user experience. User education and setting reasonable expectations of system performance is essential with systems involving backup storage.

M-Series Microinverter PV System to Encharge Pairing

The following table identifies the maximum number of microinverters that can be connected to a given Encharge storage system size.

Table 2: Maximum number of M-Series microinverters for Encharge storage system for backup operation

Encharge 3 units	Equivalent Encharge 10 units	Encharge energy capacity (kWh)	Encharge continuous power (kWAC)	Max PV system power (kWAC)	# of microinverters	
					M215	M250
1		3.26	1.28	1.92	8	8
2		6.52	2.56	3.84	17	16
3	(1x Encharge 10)	9.78	3.84	5.76	26	24
4		13.04	5.12	7.68	35	32
5		16.30	6.40	9.60	44	40
6	(2 x Encharge 10)	19.56	7.68	11.52	53	48
7		22.81	8.96	13.44	62	56
8		26.07	10.24	15.36	71	64
9	(3 x Encharge 10)	29.33	11.52	17.28	80	72
10		32.59	12.80	19.20	89	80
11		35.85	14.08	21.12	98	88
12	(4 x Encharge 10)	39.11	15.36	23.04	107	96

Warning: Under sizing power and energy capacity of the storage system may lead to a poor user experience. User education and setting reasonable expectations of system performance are essential with systems involving backup storage.

Self-Consumption Use Case

In **Self Consumption** scenarios, a homeowner's PV system generation is stored in the Encharge storage system for use later in the day when there is not sufficient power from Solar PV to supply the home loads. Homeowners benefit by consuming the onsite-generated energy themselves instead of exporting it to the grid during the day and purchasing power from the grid during evening and night times.

In customer self-consumption scenarios, size the Encharge storage capacity to accommodate the expected daily energy export. This is roughly less than two-thirds of the average daily energy load of the home.

Economic Use Cases

There are many economic goals that the Encharge storage system supports. These include **reducing the utility bill** by charging during low tariff periods and saving charge to ensure that loads can be served through the battery(ies) during the peak tariff period. Power from PV can be exported to the grid especially during peak tariff periods.

The system also supports the special case of **power export limiting**, where the utility does not allow a homeowner to export power from the PV system to the grid. Examples are the Hawaii self-supply and NEM+ programs where no export is allowed, which is called **zero export**.

Optimizing energy storage capacity sizing for economic use cases is beyond the scope of this document. You can use simulation tools like NREL SAM (System Advisor Model) or Energy Toolbase to assist with sizing in these use cases.

Smart Profiles

The Encharge storage system supports 3 smart profiles for the batteries to implement the backup, self-consumption and economic use cases described above.

These are:

1. Full Backup – 100% of the battery capacity is reserved for backup and the battery does not discharge while on-grid.
2. Self-Consumption – The battery discharges until reserved capacity to ensure the home loads are served with PV and storage as far as possible. Effectively the system tries to reduce import from the grid whenever possible. Note the battery only discharges until the reserve charge limit while on-grid. The battery discharges below the reserve charge limit only when the grid is down.
3. Savings – This profile is for the economic use case wherein the battery discharges when the rates are at the peak and charges using PV prior to peak tariff periods. Note that the Encharge storage does not export to the grid. During peak tariff period PV is exported to the grid and battery is discharged to serve loads. Note the battery only discharges until the reserve charge limit while on-grid. The battery discharges below the reserve charge limit only when the grid is down.

Description of these modes with screenshots of how homeowners can select the same is available in the [Enphase Storage system owner's guide](#).

Note in all modes the battery will charge from the grid until the reserve charge limit to ensure that the desired amount of battery charge for backup is guaranteed to be available.

Ensemble Products

Enpower Smart Switch

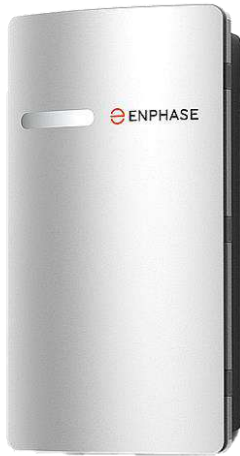

The Enphase Enpower smart switch consolidates interconnection equipment into a single enclosure and streamlines grid-independent capabilities of PV and storage distributed energy resources (DER) installations by providing a consistent, prewired solution for residential applications. Enpower is a service entrance rated microgrid interconnect device that includes a neutral-forming transformer for single-phase backup operation and an Eaton BR bus bar assembly.

- Centered mounting brackets support single stud mounting
- Supports conduit entry from the lower sides, back, or bottom
- Up to 200A rating
- Includes neutral-forming transformer for single-phase backup operation
- Includes lugs and circuits for interconnection of line-side power, PV combiner, Encharge storage system, backup load panel, and generator (to be activated in future)

Mechanical Data	Enpower
Dimensions (WxHxD):	19.7 in x 36 in x 9.7 in (50 cm x 91.6 cm x 24.6 cm)
Weight:	38.5 kg (85 lbs)
Ambient temperature range:	-40° C to +50° C (-40° to 122° F)

Model Number	Description	Shipment Contents
EP200G101-M240US00	Enphase Enpower smart switch with 200A capacity, neutral-forming transformer providing microgrid interconnect device (MID) functionality.	One box of one unit

Main and Load Breakers

For wire sizes accepted by each terminal, see the Enpower smart switch data sheet. Enpower supports optional circuit breakers on both the input (line-side) and output (load side) of the MID relay. Enpower can be configured with the following main circuit breakers to support different field requirements in compliance with NEC 705.12. Pay special attention to conductor ampacity rating when selecting the main breakers for the line-side and load side. Breakers are not included in the Enpower smart switch and must be ordered separately.

Model Number	Description	Shipment Contents
BRK-200A-2P-240V	Main breaker, 2-pole, 200A, 25kAIC, CSR2200N for Enpower	One box of one unit
BRK-175A-2P-240V	Main breaker, 2-pole, 175A, 25kAIC, CSR2175N for Enpower	One box of one unit
BRK-150A-2P-240V	Main breaker, 2-pole, 150A, 25kAIC, CSR2150N for Enpower	One box of one unit
BRK-125A-2P-240V	Main breaker, 2-pole, 125A, 25kAIC, CSR2125N for Enpower	One box of one unit
BRK-100A-2P-240V	Main breaker, 2-pole, 100A, 25kAIC, CSR2100N for Enpower	One box of one unit

Main Breaker and Load Breaker Installed in the Enpower Smart Switch

When installed on a new or existing electrical service as the service equipment disconnecting means and over current protection device, Enpower smart switch typically needs a circuit breaker installed for a main breaker and another breaker for the load breaker. The main and load breakers should be of equivalent rating of the service for whole-home (main panel) backup configurations. For example, a 200 A service would typically have two 200 A rated Eaton CSR2200N (BRK-200A-2P-240V) installed.

When Enpower is used as the service disconnect with a main bonding jumper installed, all equipment grounding conductors and neutrals on downstream feeders and panel boards must be separated.

Load Breaker Installed in the Enpower Smart Switch

If there is an existing service equipment such as an existing fusible disconnect on the line-side of Enpower, a main breaker may not be required on the line-side input of Enpower smart switch. However, a load breaker may still be required. Size the load breaker with the same rating as the system over current protection device for the whole-home (main panel) backup configuration. For example, if there is an existing 200 A meter disconnect combo feeding a main lug panel board, Enpower smart switch would be installed with a 200 A rated Eaton CSR2200N (Enphase SKU: BRK-200A-2P-240V) as a load breaker inside Enpower smart switch.

Main Breaker Installed in the Enpower Smart Switch

For the whole-home (main panel) backup configuration, if the service rating is less than 200 A, a load breaker may not be required. For example, a 100 A service has DER over current protection totaling less than 100A. In this case, Enpower smart switch would be installed with a 100 A rated Eaton CSR2100N (BRK-100A-2P-240V) as a main breaker on the line-side of the main load panel. Ensure that the sum of load and DER breakers does not exceed 200 A rating of the busbar and Enpower smart switch load conductors are rated appropriately.

Enpower Smart Switch Without Main or Load Breakers Installed

When Enpower smart switch is installed on the load side of the service equipment disconnect means, main and load breakers may not need to be installed in the Enpower. For example, an Enpower smart switch is installed with total of 40 A of DER over current protection and that is back feeding a 200 A main breaker load center. In this case, it necessary to install main or load breakers in the Enpower smart switch. Ensure that the sum of the load and DER over current protection is less than 200 A and that conductors are sized to comply with 2017 NEC 705.12(B)(2)(1).

Encharge Storage System, IQ Combiner or Generator (future) Breakers

When connecting the Encharge storage system, IQ Combiner, or generator to the Enpower smart switch, use one of the following circuit breakers depending on system requirements.

Model Number	Description	Shipment Contents
BRK-80A-2P-240V	Circuit breaker, 2-pole, 80A, 10kAIC, BR280 for Enpower	One box of one unit
BRK-60A-2P-240V	Circuit breaker, 2-pole, 60A, 10kAIC, BR260 for Enpower	One box of one unit
BRK-40A-2P-240V	Circuit breaker, 2-pole, 40A, 10kAIC, BR240B for Enpower	One box of one unit
BRK-30A-2P-240V	Circuit breaker, 2-pole, 30A, 10kAIC, BR230B for Enpower	One box of one unit
BRK-20A-2P-240V-B	Circuit breaker, 2-pole, 20A, 10kAIC, BR220B for Enpower	One box of one unit

Encharge and generator breakers may require a BRHDK125 hold down kit in accordance with 408.36(D) as referenced in NEC 710.15(E). This hold down is not required for the IQ Combiner circuits with IQ 6 / IQ 7 series microinverters since these inverters are still interactive inverters and are permitted to omit the additional fastener 2017 NEC 705.12(B)(5). This aligns with the AC coupled multimode system diagram, Figure 1, in 2017 NEC 690.1(b), which shows both an interactive and multimode inverter. Encharge storage system includes the multimode inverters forming an intentional local EPS island, and IQ 6 / IQ 7 series microinverters are utility-interactive inverters.

Generator Interface

The Enpower smart switch includes a 60 A generator connection for qualified generators (reserved for future use). This document does not address this function, as the software functionality is not yet released. The Enpower smart switch does not support integration with third-party automatic transfer switches (ATS) for the interconnection of generators. Third-party transfer switches and unqualified generators may be connected on the load side of the Enpower smart switch in compliance with NEC 705.2, and require isolating the Enphase DER equipment from the electrical system powered by unqualified generators. Such third-party transfer switches and accompanying generators cannot operate at the same time as Encharge storage systems and charge them.

Note that M-Series, microinverter-based Ensemble systems, when used with a generator, require all PV to be wired via an external contactor. The contactor’s coil must be connected to Line 2 through the control terminals of the Envoy-S Metered. This is similar to how the Envoy-S Metered is used with M-Series microinverters for Power Export Limiting in the case of customer self-supply. Details can be seen in the [Secondary Protection for Customer Self Supply](#) Tech Brief.

Encharge Storage System

The Enphase Encharge 3 and Encharge 10 storage system units are reliable, smart, simple, and safe. They provide the lowest lifetime energy costs with backup for both new and retrofit solar customers. As an installer, you can quickly design the right system size to meet the needs of the homeowner.



Each Encharge consists of a mounting bracket, battery unit with disconnecting means, and cosmetic cover.

Model Number	Description	Shipment Contents
ENCHARGE-3-1P-NA	Enphase Encharge 3 base kit with one 1.28 kVA, 3.36* kWh, single phase battery unit with four integrated IQ8X-BAT microinverters and backup feature	One box of Encharge 3 base kit
	Enphase Encharge 3 cover kit with Encharge 3 cover, mounting bracket, and screws	One box of Encharge 3 cover kit
ENCHARGE-10-1P-NA	Enphase Encharge 10 base kit with three 1.28 kVA, 3.36* kWh, single phase battery units with 12 integrated IQ8X-BAT microinverters and backup feature	Three boxes of Encharge 3 base kits
	Enphase Encharge 10 cover kit with Encharge 10 cover, mounting bracket, screws, two raceway joiners, set of wires for daisy chaining the three battery units	One box of Encharge 10 cover kit

***Note:** When used with M-Series microinverters, the Encharge 3 has a usable capacity of 3.26kWh. The Encharge 10 with 3x Encharge 3 units, therefore, has a usable capacity of 9.78kWh.

MECHANICAL DATA	Encharge 3	Encharge 10
Dimensions (WxHxD)	14.45 in x 26.14 in x 12.56 in (36.7 cm x 66.4 cm x 31.9 cm)	42.13 in x 26.14 in x 12.56 in (107.0 cm x 66.4 cm x 31.9 cm)
Weight	One each 44.2 kg (97.4 lbs) base unit plus 8.4 kg (18.6 lbs) cover and mounting bracket; total 52.6 kg (116 lbs)	Three each 44.2 kg (97.4 lbs) base units plus 24.4 kg (53.8 lbs) cover and mounting bracket; total 156.9 kg (346 lbs)
Enclosure	Outdoor - NEMA 3R	
Ambient operating temperature range	-15° C to 55° C (5° F to 131° F) non-condensing	
Optimum operating temperature range	0° C to 30° C (32° F to 86° F)	
Altitude	Up to 2500 meters (8200 feet)	
Chemistry	Lithium iron phosphate LiFePO ₄	

IQ Combiner or IQ Envoy standalone For IQ-Series Microinverters



An Enphase solar system with IQ series micros needs an IQ Combiner with an IQ Envoy or a discrete IQ Envoy. An IQ Combiner consolidates interconnection equipment for the system and houses the following:

- Multiple PV branch circuits to ensure a streamlined installation and interconnection
- IQ Envoy – This collects production and performance data from the storage system and from the IQ series microinverters. It then transmits the data to Enlighten through ethernet, Wi-Fi, and cellular.

A standalone IQ Envoy can also be used if needed.

The IQ Combiner 3-ES and the IQ Combiner 3C-ES include the consumption CTs. However, if using an existing IQ Envoy or IQ Combiner on a site that does not have the consumption CTs, a pair of consumption CTs (CT-200-SPLIT) must be procured and installed.

The IQ Combiner 3C-ES includes a cellular modem, so an Ensemble Communications Kit without a cellular modem (i.e. COMMS-KIT-01) can be used with this combiner for Ensemble installations

Model Number	Description	Shipment Contents
X-IQ-AM1-240-3-ES	AC combiner with IQ Envoy PCB, 80A, 240V split-phase Includes a pair of consumption CT's (CT-200-SPLIT - Split-core current transformer, accuracy +/- 2.5%) Also includes a solar shield (XA-SOLARSHIELD-ES) that matches with the Ensemble aesthetics and deflects heat	1 Box of 1 Unit
X-IQ-AM1-240-3C-ES	AC combiner with IQ Envoy CR PCBA, 80A, 240V split-phase, with integrated CELLMODEM-M1, silver solar shield and includes 2x CT-200-SPLIT	1 Box of 1 Unit
ENV-IQ-AM1-240	Enphase IQ Envoy, single phase, metered. Revenue grade accuracy (ANSI C12.20 +/- 0.5%) with calibrated solid-core CT.	1 Box of 1 Unit

Envoy-S Metered For M-Series Microinverters

The Enphase Envoy-S communications gateway delivers solar production and energy consumption data to Enphase Enlighten™ monitoring and analysis software for comprehensive, remote maintenance and management of the Enphase Microinverter System.



The Envoy-S Metered is packaged with one production current transformer to enable accurate production monitoring with an accuracy of +/-2.5%. For consumption monitoring, two consumption current transformers (CT-200-SPLIT) must be purchased by the installer.

Model Number	Description	Shipment Contents
ENV-S-AM1-120	Enphase Envoy-S, Metered. Single phase, Revenue grade accuracy (ANSI C12.20 +/- 0.5%) with Production CT	1 Box of 12 Units

Ensemble Communications Kit



The Ensemble communications kit includes the COMMS-KIT-01 and the CELLMODEM-M1. The COMMS-KIT-01 is plugged into a USB port on Envoy-S. It enables direct communication between the Encharge storage system, the Enpower smart switch, and the Envoy-S using 2.4 GHz frequency. The CELLMODEM-01 is an LTE CAT-M1 cellular modem with a five-year AT&T data plan for Ensemble systems. It acts as a backup for a broadband Wi-Fi or Ethernet connection and ensures connectivity to the Enlighten cloud.

If the site already has a cellular modem the COMMS-KIT-01 is also available independently.

Model Number	Description	Shipment Contents
COMMS-CELLMODEM-M1	COMMS-KIT-01: USB adapter kit for Envoy. Enables wireless communication with Encharge and Enpower CELLMODEM-M1: LTE CAT M1 cellular modem. When purchased as part of COMMS-KIT-M1 it includes a five-year data plan for Ensemble systems with up to 60 microinverters, 12 Encharge 3 batteries and one Enpower. Works in US, Puerto Rico, US Virgin Islands, Canada, and Mexico.	1 Box of 1 Unit
COMMS-KIT-01	USB adapter kit for Envoy. Enables wireless communication with Encharge and Enpower	1 Box of 1 Unit

M-Series Microinverters Replacements

Enphase provides M-Series RMA SKUs based in the IQ7 hardware platform to replace M-Series microinverters that have failed or to expand an existing M-Series site. Note that you cannot mix IQ6- and IQ7-Series microinverters SKUs with M-Series microinverters at a site. You can only use the SKUs provided below with M-Series microinverters at a site.

SKU	Description
M215240-IQ7-S22-US	M215 240VAC microinverter based on 7th generation IQ Series; MC locking connector, for existing M215 system expansion or replacing out-of-warranty M215 microinverters
M215240-IQ7-S25-US	M215 240VAC microinverter based on 7th generation IQ Series; Amphenol H4 connector, for existing M215 system expansion or replacing out-of-warranty M215 microinverters
M250240-IQ7-S22-US	M250 240VAC microinverter based on 7th generation IQ Series; MC locking connector, for existing M250 system expansion or replacing out-of-warranty M250 microinverters
M250240-IQ7-S25-US	M250 240VAC microinverter based on 7th generation IQ Series; Amphenol H4 connector, for existing M250 system expansion or replacing out-of-warranty M250 microinverters

When using the M-Series RMA SKUs you must use the Engage Cable and associated accessories. The following table lists these.

SKU	Description
ET10-240-BULK	Voltage type and conductor count: 240 VAC, four conductors Connector count: 240 Connector spacing: 1.025m (40") PV module orientation: Portrait
ET17-240-BULK	Voltage type and conductor count: 240 VAC, four conductors Connector count: 240 Connector spacing: 1.7m (67") PV module orientation: Landscape
ET-SPLK-05	Pack of five Engage couplers. Used to connect two Engage Cables
ET-CLIP-100	Pack of 100 steel clips to fasten the Engage Cable to racking
ET-INSTL	Includes: <ul style="list-style-type: none"> • Pack of four ET-TERM terminators for Engage Cables • One ET-DISC disconnect tool used to disconnect M-Series microinverters from Engage Cable • Pak of five ET-SEAL sealing caps for unused connectors on the Engage Cable

Note that the cables and accessories listed above are available only through the Enphase store.

Component List

The following table lists the required components for installation of new systems and retrofitting an existing Enphase system:

Component	Name (Model Number)	New System (Quantity)	Retrofit IQ System (Quantity)	Retrofit M215/M250 System (Quantity)	Retrofit Enphase Non-IQ6/7 and Non-M215/M250 System (Quantity)
Energy Storage System (ESS)	Encharge: Encharge-3-1P-NA Encharge-10-1P-NA	Encharge 3s and Encharge 10s (See pairing chart for minimums)	Encharge 3s and Encharge 10s (See pairing chart for minimums)	Encharge 3s and Encharge 10s (See pairing chart for minimums)	Encharge 3s and Encharge 10s (See pairing chart for minimums)

Component	Name (Model Number)	New System (Quantity)	Retrofit IQ System (Quantity)	Retrofit M215/M250 System (Quantity)	Retrofit Enphase Non-IQ6/7 and Non-M215/M250 System (Quantity)
Microgrid Interconnection Device (MID)	Enpower: EP200G101-M240US00	1	1	1	1
Enpower Switch Main Breaker and/or Load Breaker	Enpower Main Breakers: BRK-200A-2P-240V BRK-175A-2P-240V BRK-150A-2P-240V BRK-125A-2P-240V BRK-100A-2P-240V	0, 1 or 2	0, 1 or 2	0, 1 or 2	0, 1 or 2
Enpower Switch Circuit Breakers for PV and Encharge Circuits	Enpower Circuit Breakers: BRK-20A-2P-240V-B BRK-30A-2P-240V BRK-40A-2P-240V BRK-50A-2P-240V BRK-60A-2P-240V BRK-80A-2P-240V	2	2	2	2
Ensemble Technology System Communications (between ESS, MID and Combiner)	Ensemble Communications Kit: COMMS-CELLMODEM-M1 OR COMMS-KIT-01 (if system already has cellular modem or if using an IQ Combiner SKU that already has a cellular modem)	1	1	1	1
IQ Combiner	IQ Combiner: X-IQ-AM1-240-3-ES OR X-IQ-AM1-240-3C-ES	1	0	0	1
Standalone Gateway	IQ Envoy for IQ series ENV-IQ-AM1-240	1 (If not using IQ Combiner)	0	1 (If not already present on site)	0
	Envoy-S Metered for M-Series ENV-S-AM1-120	0	0	1 (If not already present on site)	0
Consumption CTs	Current Transformers: CT-200-SPLIT	2 (If not using a new IQ Combiner that ships with consumption CTs)	2 (one for each phase) (If system doesn't already have CTs)	2 (one for each phase) (If system doesn't already have CTs)	2 (one for each phase) If system doesn't already have CTs
Microinverters	IQ7 Series or IQ6 Series	As needed per system design	None needed unless expanding or replacing existing microinverters (comply with pairing ratio)	N/A	Upgrade to IQ7 or IQ 6 Series Microinverters needed (comply w/ pairing ratio)

Component	Name (Model Number)	New System (Quantity)	Retrofit IQ System (Quantity)	Retrofit M215/M250 System (Quantity)	Retrofit Enphase Non- IQ6/7 and Non- M215/M250 System (Quantity)
	M215/M250 M-Series RMA SKUs: M215240-IQ7-S22-US M215240-IQ7-S25-US M250240-IQ7-S22-US M250240-IQ7-S25-US	N/A	N/A	None needed unless expanding or replacing existing microinverters (comply with pairing ratio)	N/A
PV Modules	Any	As needed per system design	None needed unless expanding	None needed unless expanding	Existing or new panels

Key Planning Considerations

To ensure optimal wireless and power line communication between Ensemble system products and cleanest installation, consider the following:

1. Identify a suitable environment for temperature, enclosure ratings, and wall area, for secure mounting of the weight of the required Encharge storage system and Enpower smart switch units.
2. For wireless communications between the Envoy, Encharge storage system, and Enpower smart switch, the best practice is to have a line-of-sight between them.
3. For power line communications, the best practice is to have the Envoy located closest to PV branch circuit collection, for example in an IQ Combiner or near/in an off-the shelf PV combiner.
4. Determine the electrical interconnection points and required breakers for Enpower smart switch, Encharge storage system circuit, PV combiner branch circuits, and the Envoy.
5. Ensure that the Envoy with both production and consumption CTs can be installed at the site.
6. Size conductors properly for ampacity and voltage regulation given conductor lengths.
7. Identify the location the PV system disconnect for rapid shutdown initiation and labeling.
8. Always ensure that the Envoy is connected to the internet via a Wi-Fi or ethernet connection. Note that the cellular modem is provided as a **backup** connection for internet connectivity.

The following sections detail each of these considerations:

Physical Installation Considerations

1. For all products, always follow the instructions in the Enphase installation manuals.
2. Following local standards, choose a well-ventilated location where the ambient temperature and humidity are within equipment specifications, preferably out of direct sunlight. The Encharge storage system battery does not require additional ventilation as Lithium Iron Phosphate (LFP) chemistry used in battery cells does not off-gas.
3. Ensure that the mounting location can sustain the weight of the equipment, mounting equipment, and accessory equipment.
4. Plan the mounting location of Encharge:
 - Minimum distance between Encharge units shall be 6 inches.
 - Indoors: at least 15 cm (6 inches) off the ground and 15 cm (6 inches) from the ceiling.
 - Outdoors: at least 15 cm (6 inches) off the ground.
 - If mounted in the path of a motor vehicle, we recommend a 91cm (36 inches) minimum mounting height
5. Plan the mounting location of **Enpower**:
 - Indoors: at least 15 cm (6 inches) off the ground and 15 cm (6 inches) from the ceiling.
 - Outdoors: at least 91cm (3 feet) off the ground.
 - Indoors: at least 15 cm (6 inches) off the ground and 15 cm (6 inches) from the ceiling.
 - Outdoors: at least 15 cm (6 inches) off the ground.
 - If mounted in the path of a motor vehicle, we recommend a 91cm (36 inches) minimum mounting height
6. Ensure that there are no pipes or electrical wires where you plan to drill.
7. Plan to maintain at least 90 cm (three feet) of clearance in front of Ensemble technology equipment for working space.
8. Consider the dimensions of the Ensemble equipment, easy access, height, and length of system conductors and conduit requirements between products and the system interconnection location when selecting the location of equipment. The recommended minimum spacing is shown in the following figure and table. Conduit options are as follows:
 - Enpower smart switch – Main supply conductors may enter Enpower smart switch from the bottom or from the bottom-left side. Backup load conductors may enter Enpower smart switch from the bottom or bottom-right side. Encharge storage system and PV combiner and generator conductors may enter from the bottom, bottom-left or bottom-right sides.
 - Encharge storage system – Conduit may enter from the top right or top left of the Encharge storage system at the pre-defined knockout locations.
 - IQ Combiner series – Conduit may enter at the bottom and sides or rear entry below the busbar assembly.
9. Do not block vents.

Figure 11: Bracket Spacing

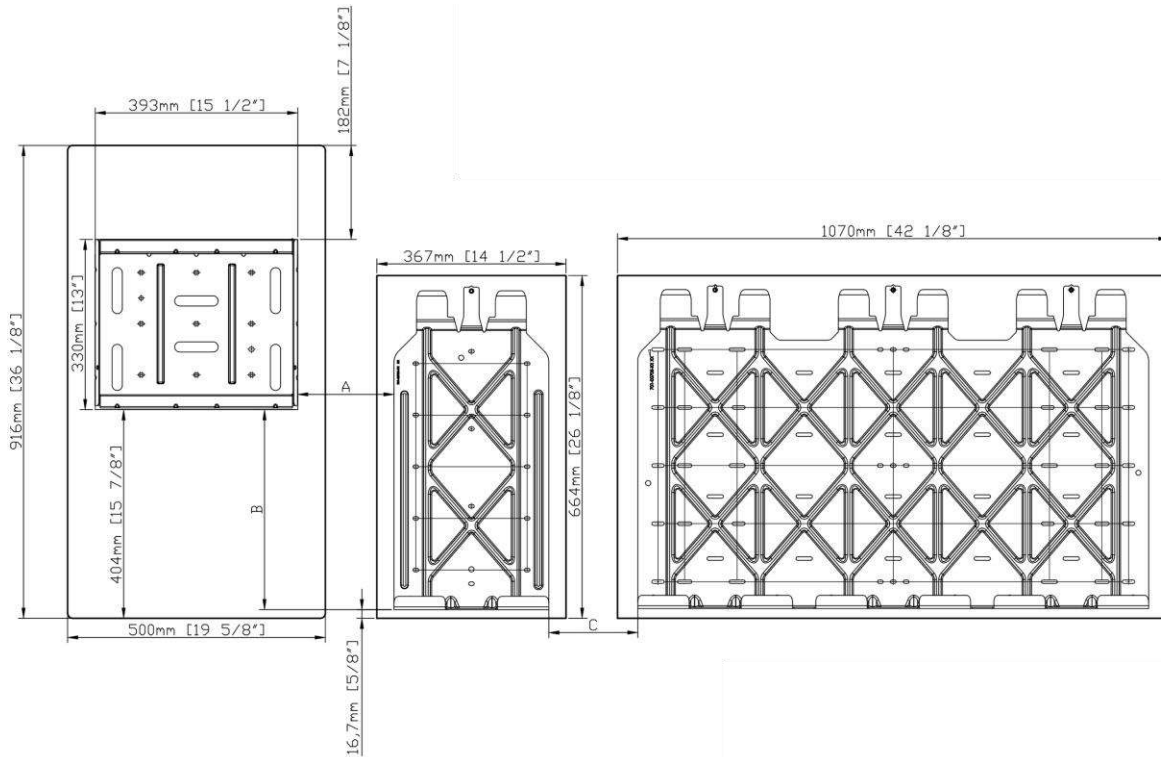

Bracket Spacing

Dimension	Description	Recommended Minimum
A	Enpower and Encharge horizontal bracket spacing	152 mm (6")
B - Bottom aligned	Enpower wall mount bracket bottom to Encharge wall mount bracket bottom	387 mm (15 1/4")
B - Center aligned	Enpower wall mount bracket bottom to Encharge wall mount bracket bottom	261 mm (10 5/16")
B - Top aligned	Enpower wall mount bracket bottom to Encharge wall mount bracket bottom	135 mm (5 5/16")
C	Encharge wall horizontal bracket spacing	152 mm (6")

Temperature Considerations

Unlike other battery chemistries, an Encharge storage system does not require ventilation for off-gassing and does not require active cooling. Encharge storage system batteries perform best when not subjected to extreme hot or cold temperatures and remain within the optimal temperature range of 0° C to 30° C (32° F to 86° F). Temperature may be affected by location, exposure, and ventilation. Consider factors that may result in undesirable temperature swings outside the optimal temperature range. For example, in enclosed unconditioned spaces such as garages or utility closets, the temperature may be higher than the outdoor ambient.

Electrical Installation Requirements

For full installation instructions, always refer to the Enphase Installation Manuals, including the following documents:

- *Quick Install Guide – Install the Enphase Encharge Storage System*
- *Quick Install Guide – Install the Enphase Enpower Smart Switch*

Current Transformers (CTs)

It is critical that installers correctly configure the Envoy, with the combined solar PV output passing through the production CT. The production CT monitors **only** the PV output circuit(s) and must not have Encharge battery circuit(s) installed on it. Install the Encharge battery circuit(s) on the load side of the production CTs on the correct terminals in Enpower smart switch.

Installers may extend the consumption CT leads, but not the production CT leads. Therefore, it is best to locate the Envoy close to the microinverter output circuits and then extend consumption CT wires if necessary. Refer to the [IQ Envoy Installation and Operations Manual](#) or the [Enphase Envoy-S Installation and Operation Manual](#) when installing and/or extending consumption CTs. Refer also to the [Tech Brief: Four Guidelines for Successful Current Transformer \(CT\) Installation](#).

Enpower Smart Switch Connections

The Enpower smart switch can accept a maximum of 64 A of continuous output current (maximum 80A breaker) of a combined PV subpanel or IQ Combiner (labeled AC Combiner). The busbar in the Enpower smart switch can accept a maximum of an 80 A breaker for the IQ Combiner over current protection.

The Enpower smart switch can accept a maximum of 64 A of rated output current (maximum 80A breaker) of combined Encharge storage system circuits. The busbar in the Enpower smart switch can accept a maximum of an 80 A breaker for the Encharge storage system circuit over current protection. This equates to a maximum of twelve Encharge 3 storage units **or** four Encharge 10 units per Enpower. Up to six Encharge 3 storage units **or** two Encharge 10 units, equal to 32 A of rated output current, can be connected in series prior to landing on the Encharge terminal in the Enpower smart switch and protected by a no higher than a 40 A over current protection breaker. If more than six Encharge 3 storage systems (or more than two Encharge 10 storage systems) are to be connected to Enpower smart switch, an external subpanel must be used to combine each circuit of up to 32 A of rated output current Encharge storage system circuits. You should size conductors appropriately for the overcurrent protection selected for the application.

Voltage Regulation Considerations

When the Encharge storage system is charging, it acts like a load, and the voltage decreases at the terminals of the battery based upon Ohm's law and wire resistance. When the Encharge storage system is discharging to feed loads, it behaves like a source, and the voltage increases at the terminals of the battery.

The voltage rise to voltage drop delta divided by the nominal voltage is roughly equivalent to voltage regulation. Since the peak charge and discharge values for Encharge are the same value, voltage rise and voltage drop will be the same value.

Voltage regulation in Ensemble is calculated as

$$\text{Percent VR} = \frac{2 \cdot |V_d|}{V_{nom}}$$

where:

V_d is the voltage change from 0 to max current out of Encharge, and
 V_{nom} is the nominal RMS voltage.

Ensure that the Encharge storage system conductors are sized correctly for the number of units on the circuit and voltage regulation does not exceed 1% between the first Encharge storage system and Enpower smart switch.

Rapid Shutdown Considerations

2017 NEC 690.12 requires a rapid shutdown for PV Systems on buildings by an initiation device in a readily accessible location. In grid interactive systems this is often the service disconnecting means or PV system disconnect. Rapid shutdown requirements do not apply to optional standby systems such as energy storage and as seen in Figure 1, the PV system disconnect can still initiate rapid shutdown.

The rapid shutdown initiation device can be either:

- the PV system breaker in Enpower,
- an additional disconnect such as a fusible disconnect between Enpower and the IQ Combiner, or
- the circuit breakers in the IQ Combiner since these breakers are less than six and grouped.

The rapid shutdown initiator must be labeled in accordance with 2017 NEC 690.56.

Enphase IQ 6 / 7 series and M215 and M250 microinverters comply with the rapid shutdown requirements per the UL certifications.

Glossary

distributed energy resource (DER): A source of electric power that is not directly connected to a bulk power system. DER includes both generators and energy storage technologies capable of exporting active power to an EPS. An interconnection system or a supplemental DER device that is necessary for compliance with this standard is part of a DER. (IEEE 1547-2018)

intentional island: An intentionally planned electrical island that is capable of being energized independently of the area electric power system (EPS). Enpower and Encharge comprise a microgrid system that forms an intentional island totally within the bounds of the Local EPS. (2017 NEC/IEEE 1547-2018/IEEE 1547.1-2011)

main load panel: Also referred to as the main load center or main panelboard, this is the unit where the majority of load circuits for the premises have over current protection.

microgrid interconnect device (MID): A device that allows a microgrid system to separate from and reconnect to a primary power source. (NEC 705.2)

microgrid system: A premises wiring system that has generation, energy storage, and load(s), or any combination thereof, that includes the ability to disconnect from and parallel with the primary source. (NEC 705.2)

multimode inverter: Equipment having the capabilities of both the interactive inverter and the stand-alone inverter. (NEC 705.2)

service: The conductors and equipment for delivering electric energy from the serving utility to the wiring system of the premises served. (NEC CMP-4)

service equipment: The necessary equipment, usually consisting of a circuit breaker(s) or switch(es) and fuse(s) and their accessories, connected to the load end of service conductors to a building or other structure, or an otherwise designated area and intended to constitute the main control and cutoff of the supply. (NEC CMP-4)

voltage regulation: The measure of change of voltage magnitude in a component such as a feeder. Poor voltage regulation may result in unwanted behavior such as dimming lights or flicker.

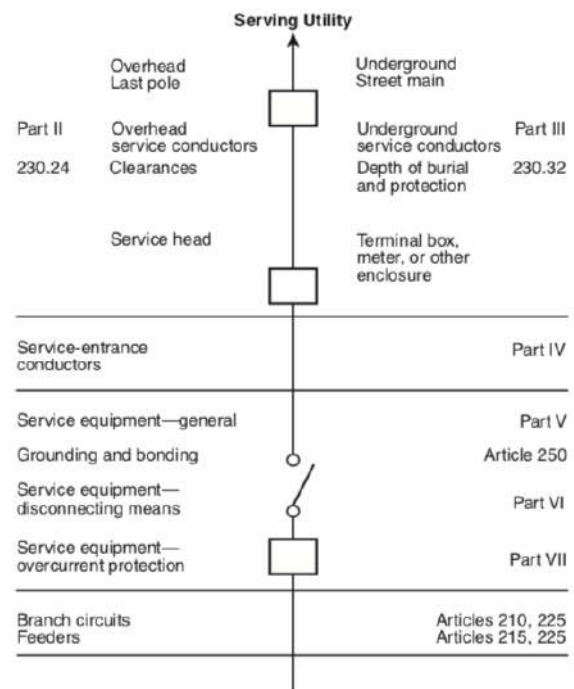
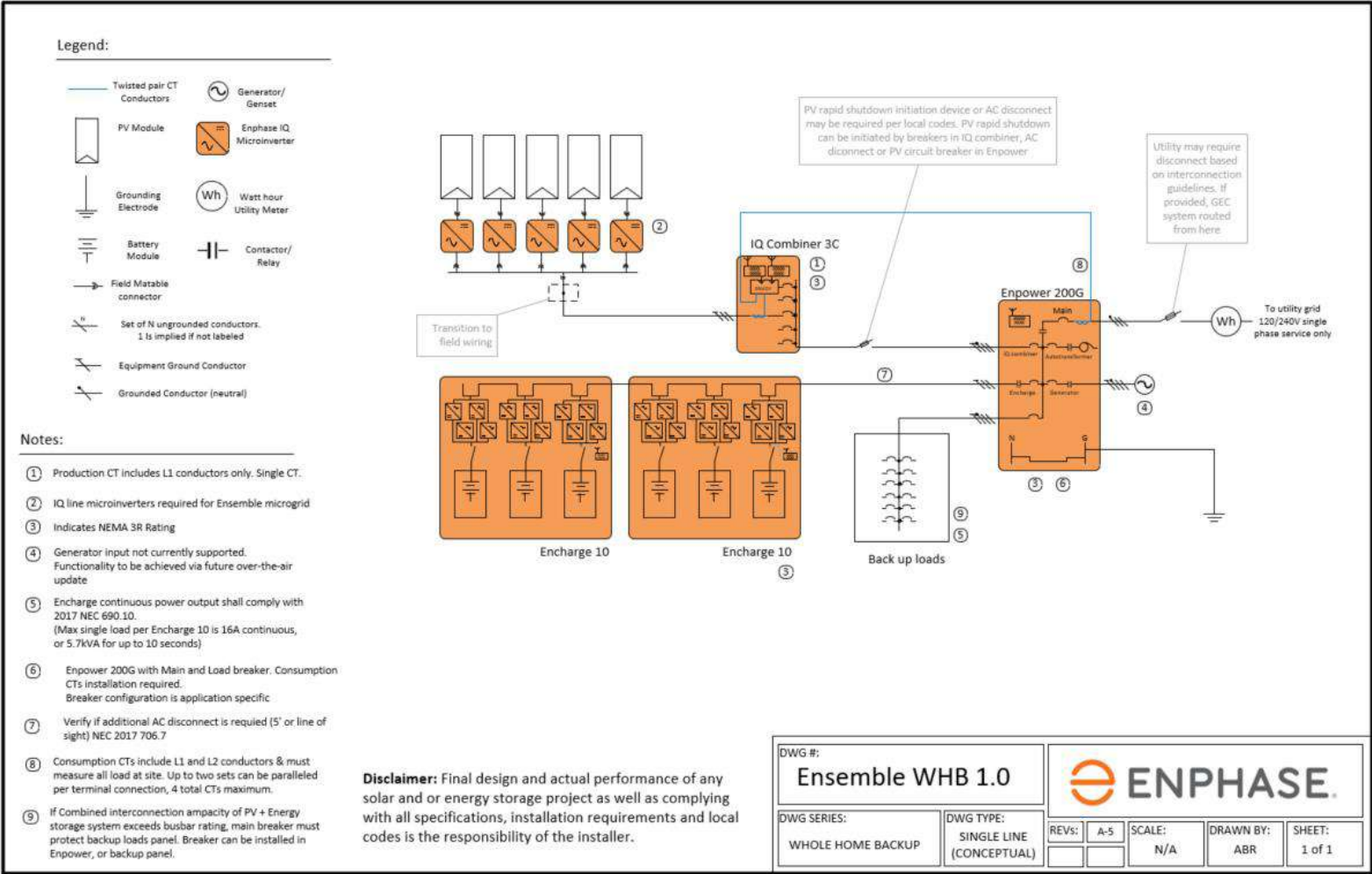

Figure 12: NEC 2017 Figure 203.1 Services © NFPA

Appendix A – Single line diagrams for IQ-Series systems

Whole home backup configuration



Partial home backup configuration

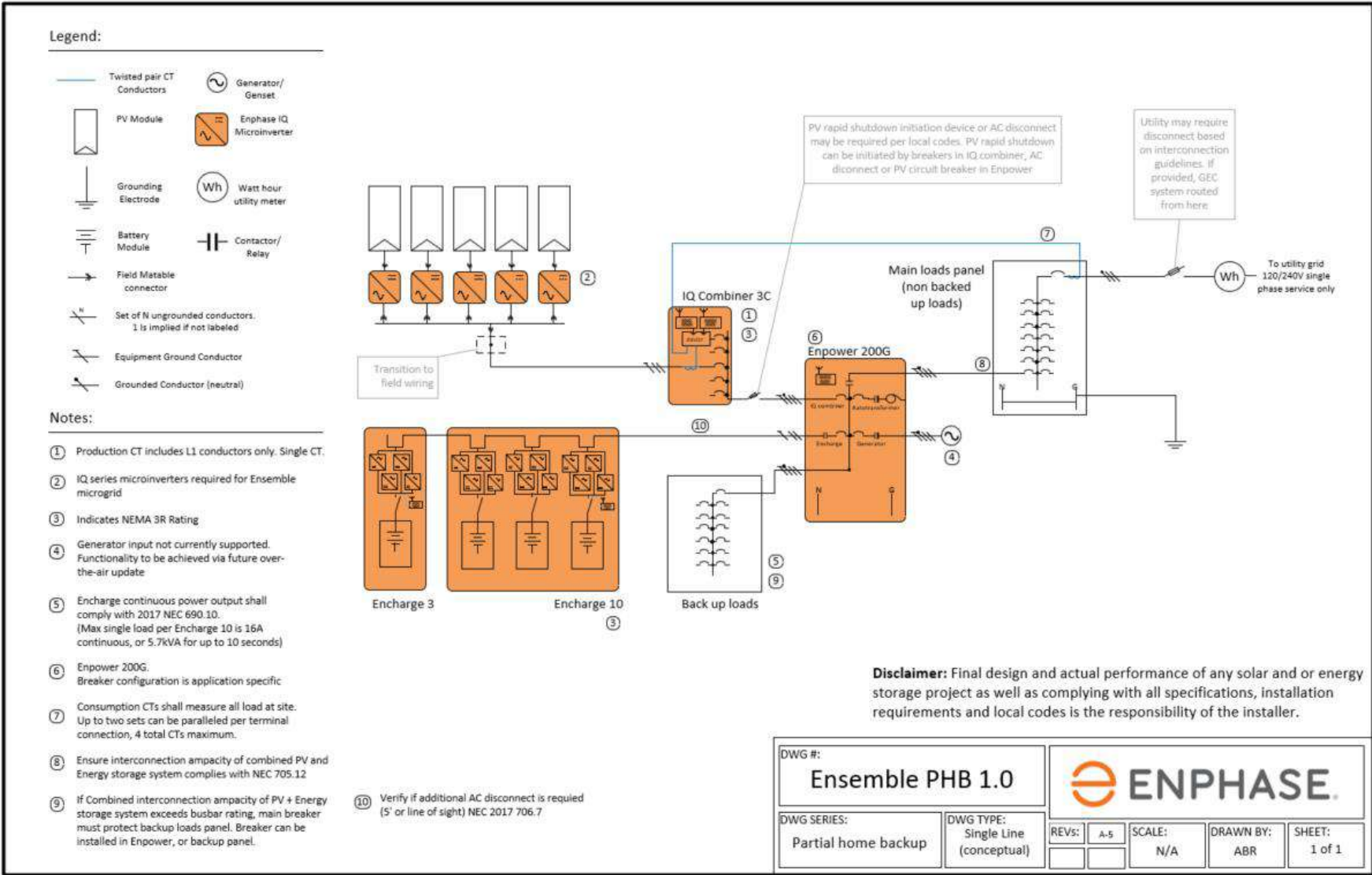

Partial home backup configuration, split system with additional consumption CTs

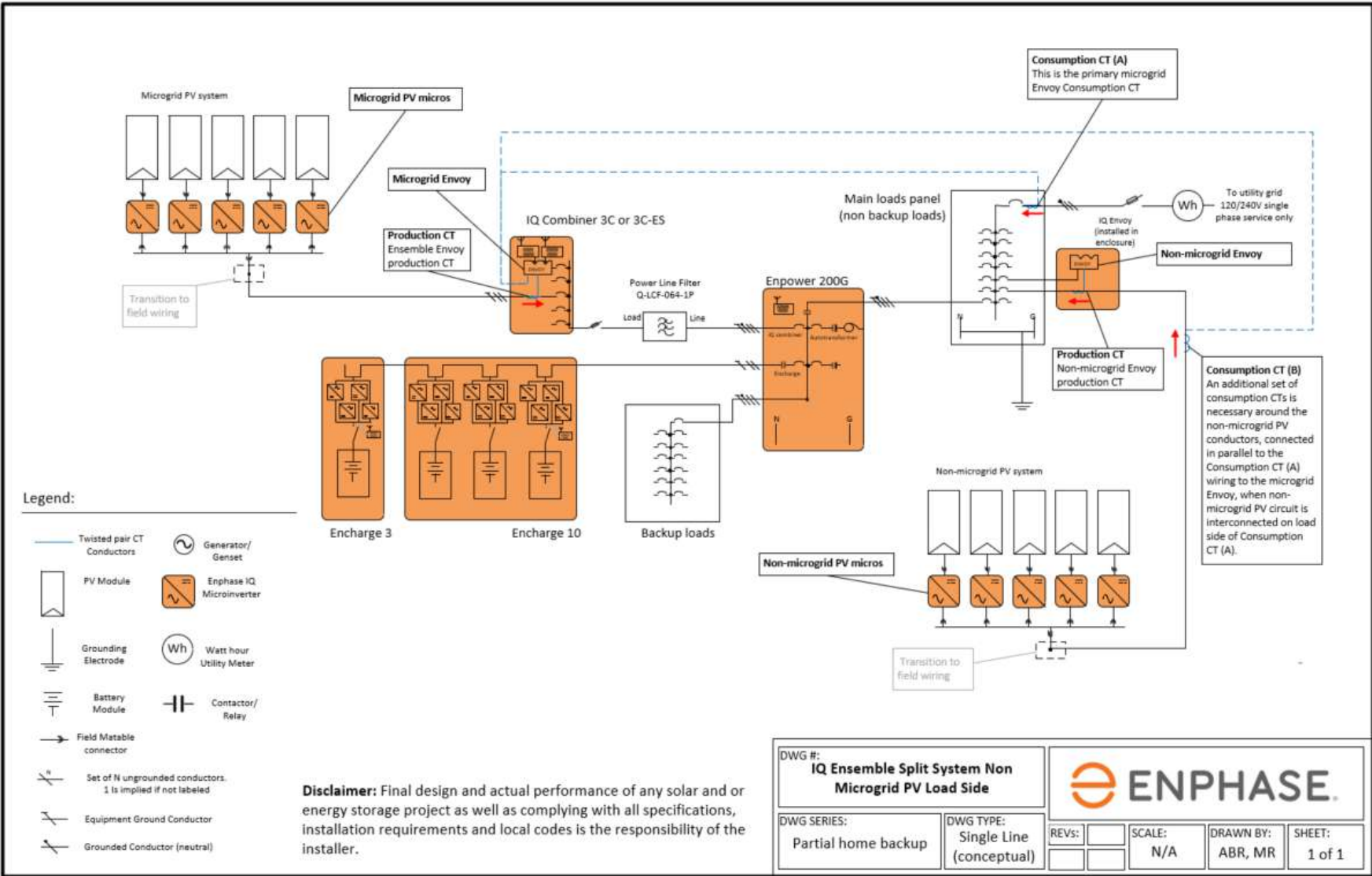

Partial home backup configuration, split system with NO additional consumption CTs

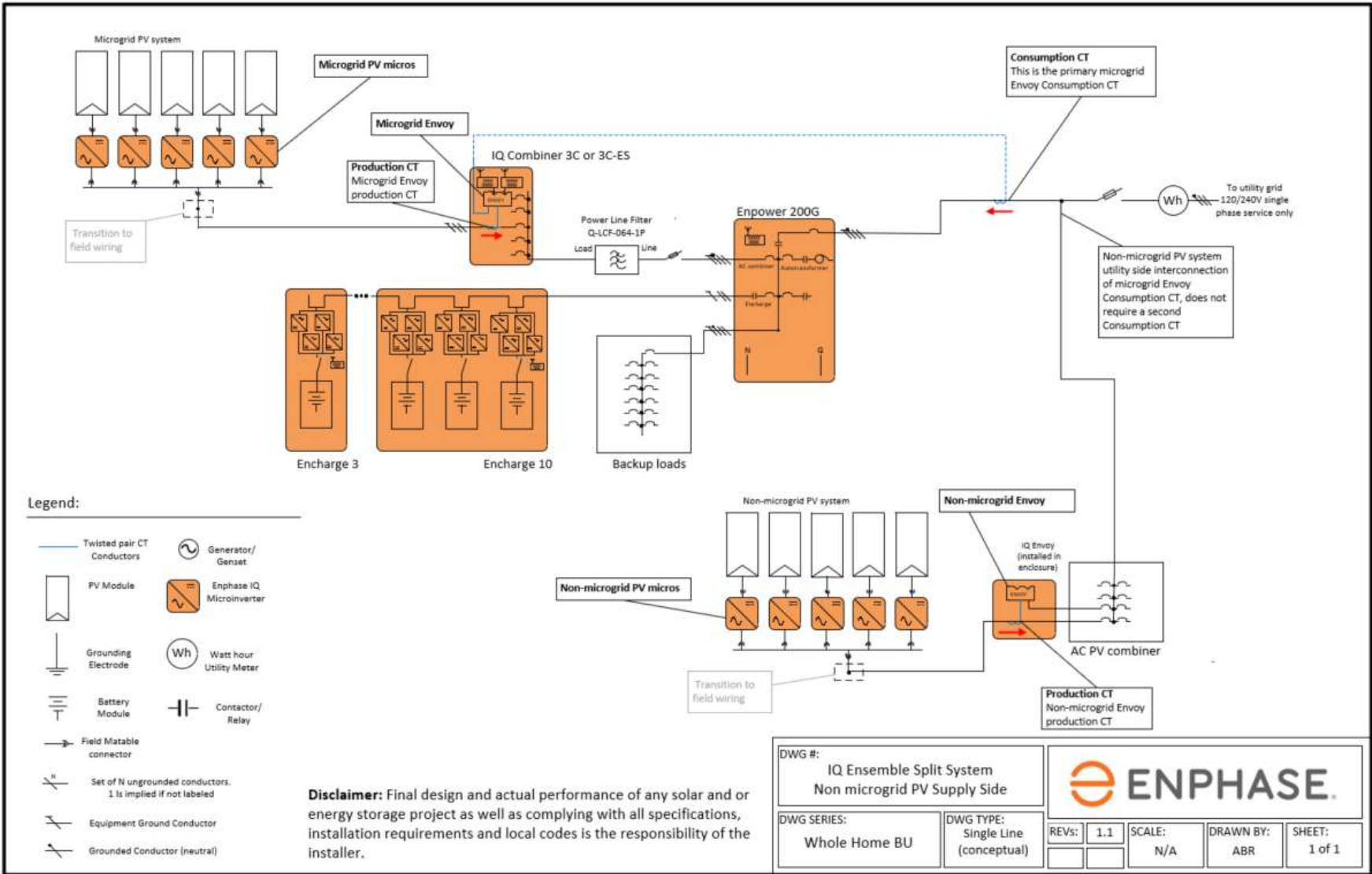

Encharge only configuration

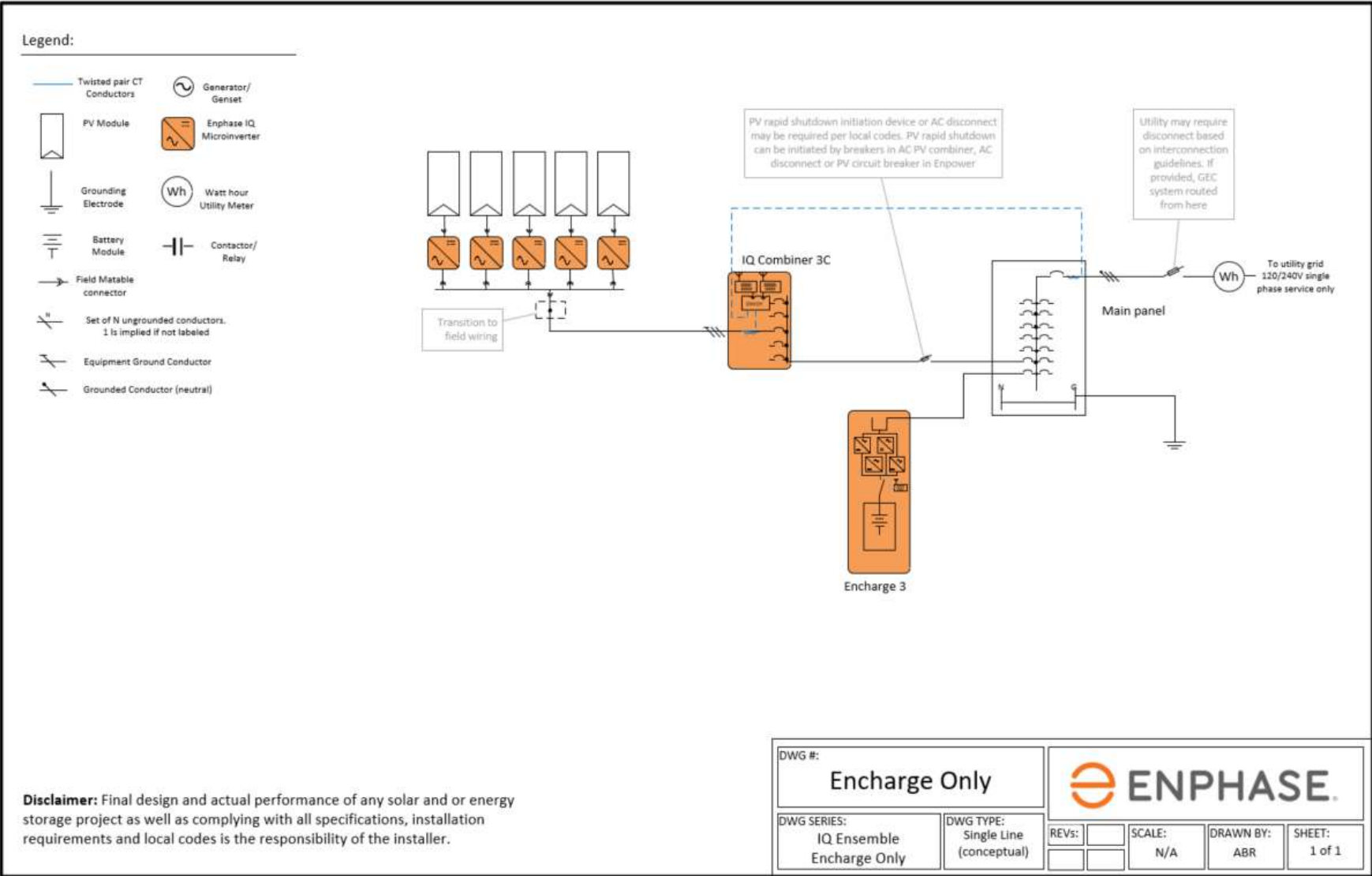

Appendix B – Single line diagrams for M-Series systems

(Download [here](#))

Whole home backup configuration

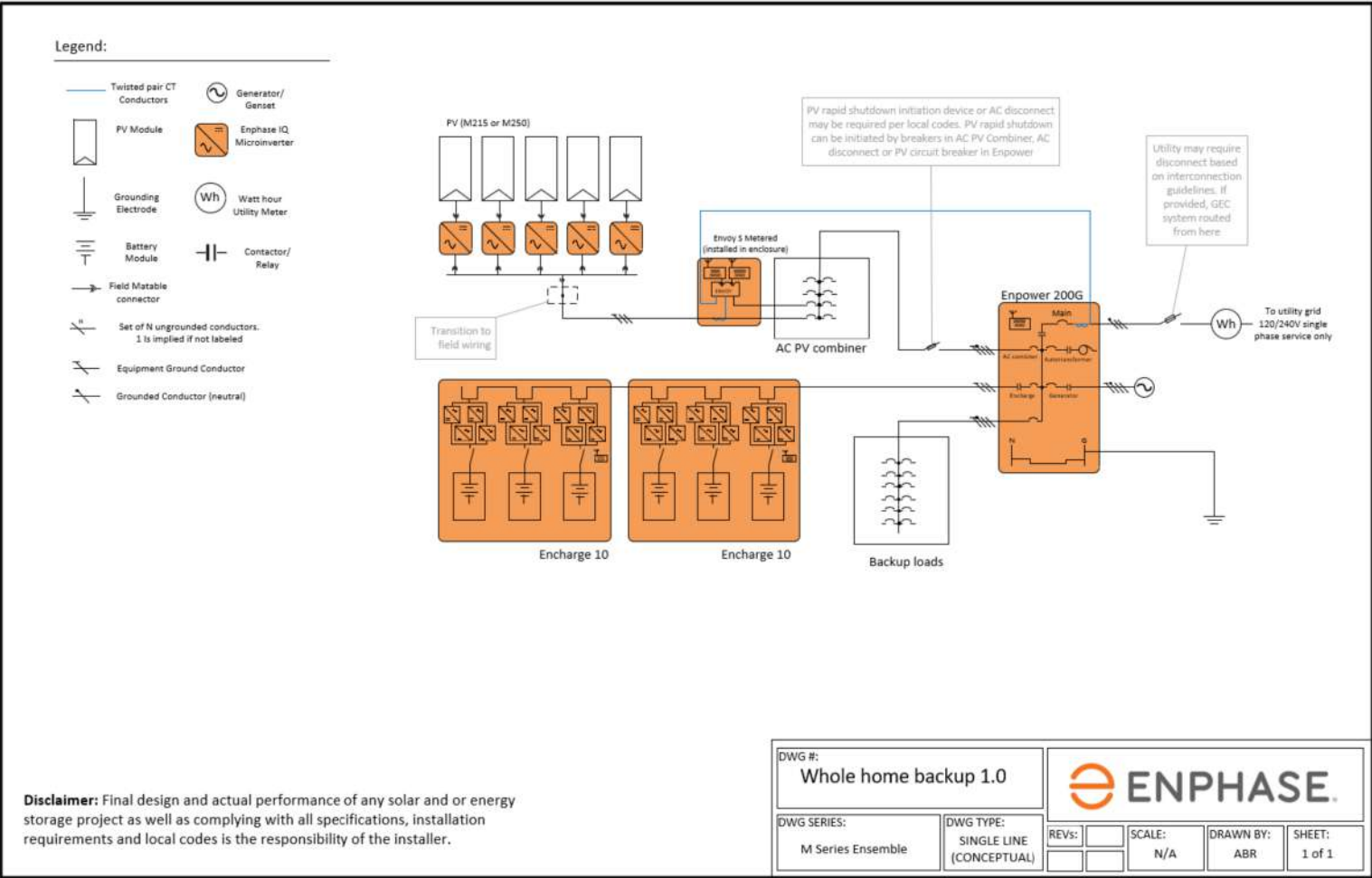

Partial home backup configuration

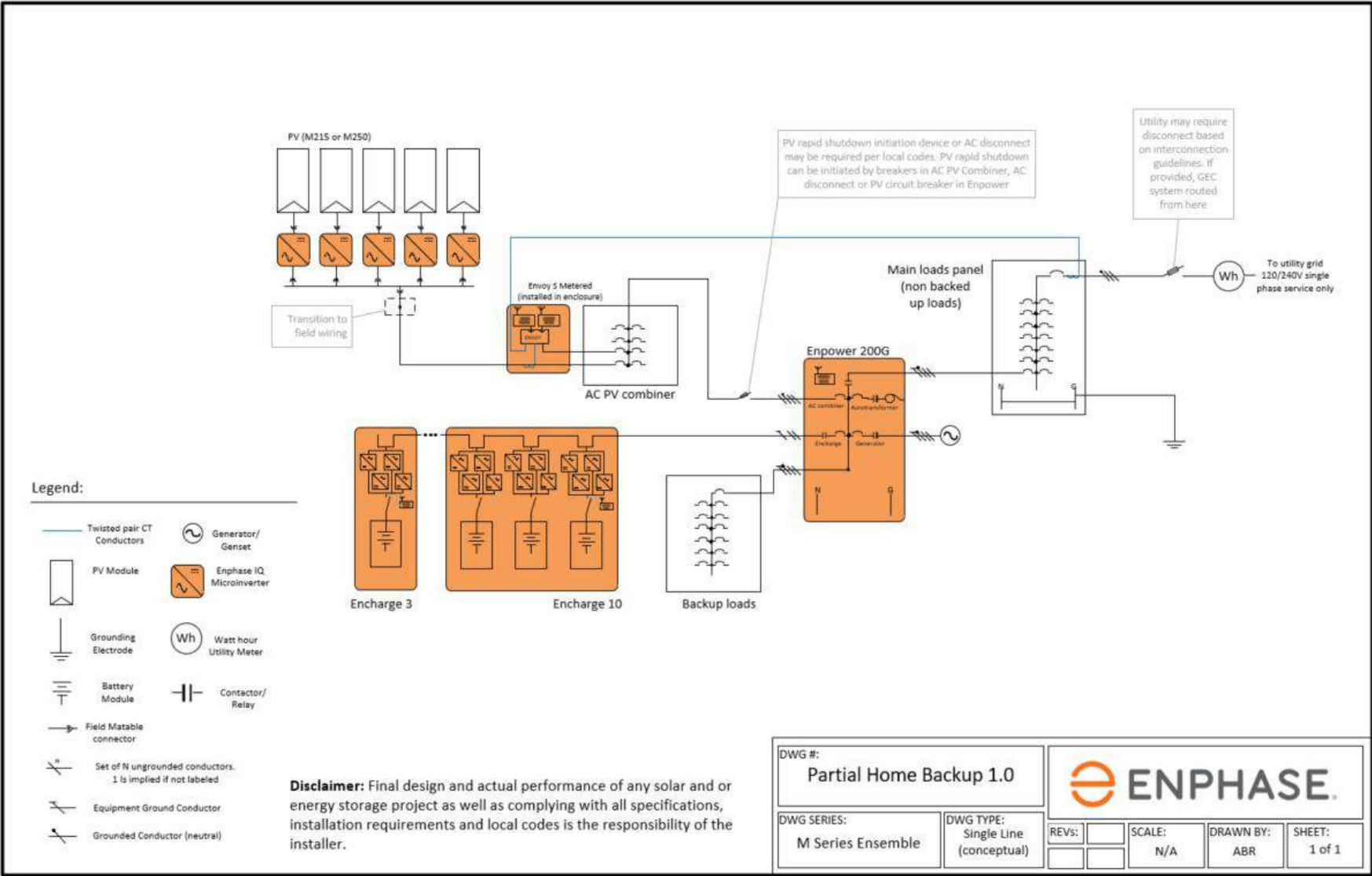

Partial home backup configuration, split system with NO additional consumption CTs

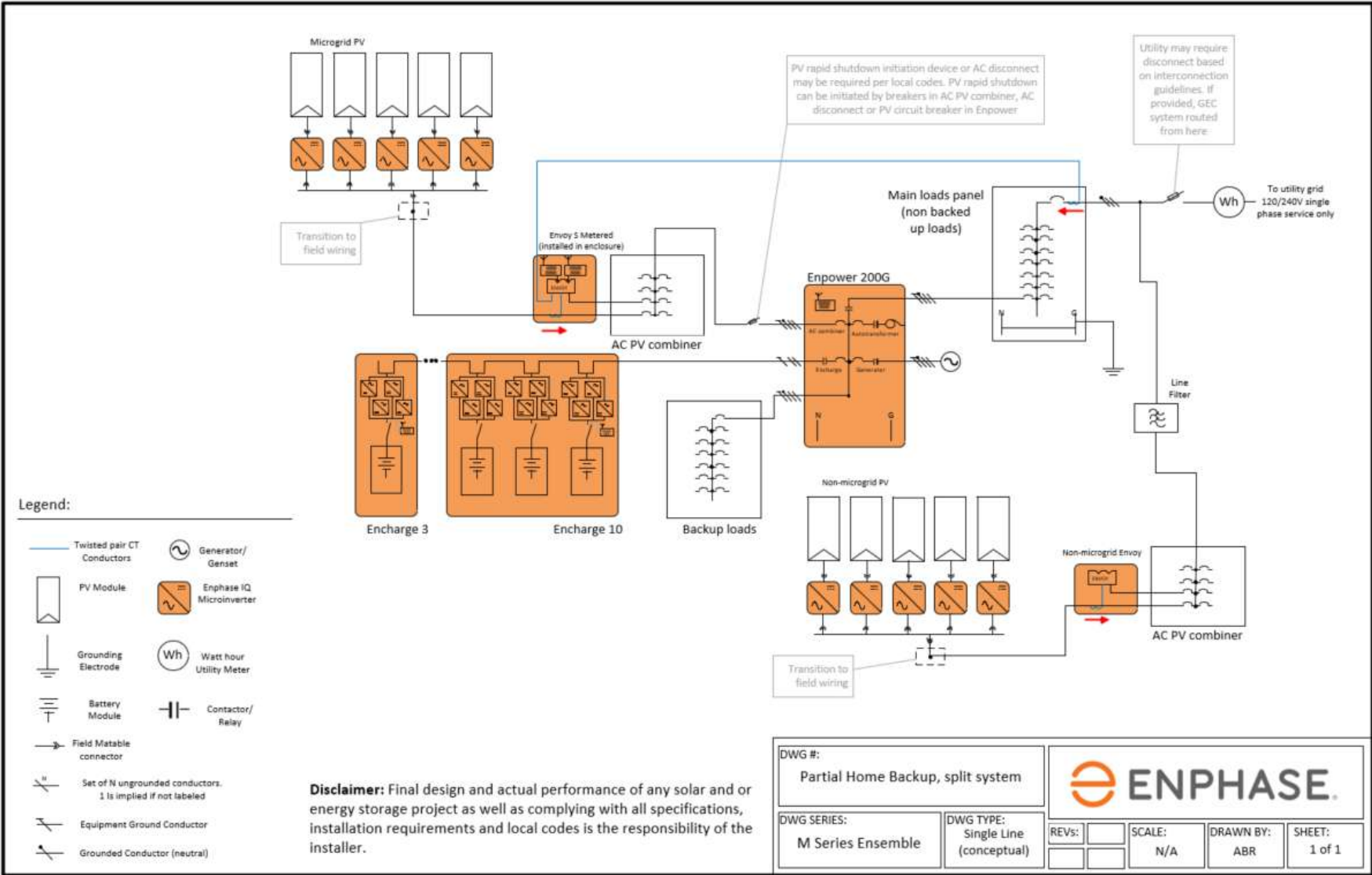

Encharge only configuration

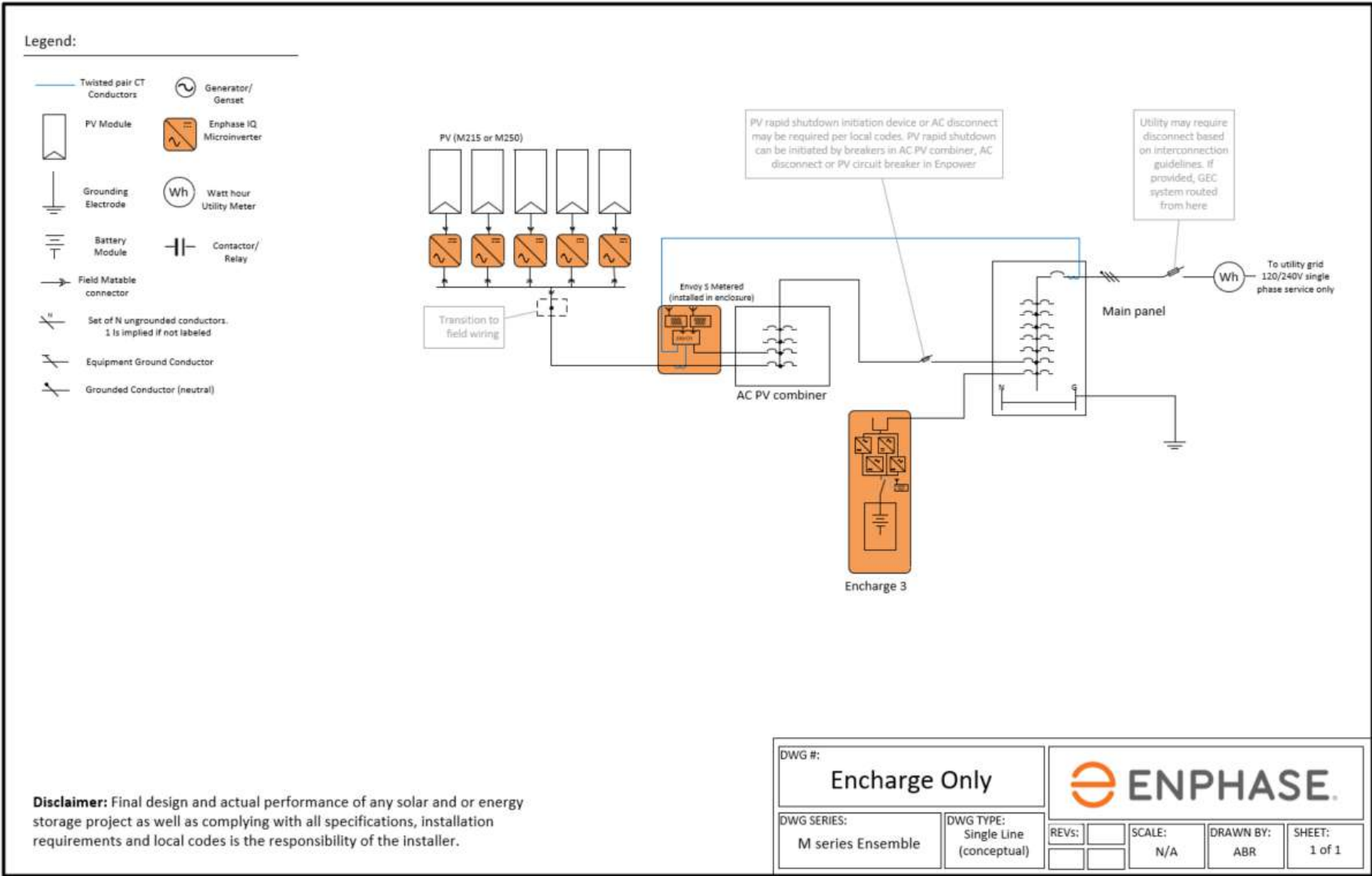

Disclaimer: Final design and actual performance of any solar and or energy storage project as well as complying with all specifications, installation requirements and local codes is the responsibility of the installer.

DWG #: Encharge Only					
DWG SERIES: M series Ensemble	DWG TYPE: Single Line (conceptual)	REVS:	SCALE: N/A	DRAWN BY: ABR	SHEET: 1 of 1