



DPW | SOLAR



PREFORMED LINE PRODUCTS



Top-of-Pole Mount for 12 Modules (TPM12) For Module Types D, E, F, & G When High Wind Version (HWV) or 6h x 2w, L

ASSEMBLY INSTRUCTIONS

**step-by-step
assembly and installation**

Top-of-Pole Mount for 12 Modules (TPM12) For Module Types D, E, F, & G When High Wind Version (HWV) or 6h x 2w, L

A few words about the product

The TPM12 for module types D, E, F, & G when High Wind Version (HWV) or 6h x 2w, L is designed to mount on 8 inch SCH40/80 galvanized steel pipe (installer supplied).

Pipe size and foundation requirements are based on several factors including the array surface area, maximum design wind speed, exposure category, soil type, steepest expected tilt angle, and above-ground clearance.

For foundation and pipe size recommendations on a specific installation, please contact us at:

Phone: 800-260-3792

Email: info@dpwsolar.com

About these Assembly Instructions

These instructions...

- Are intended to be used by individuals with sufficient technical skills for the task. Knowledge and use of hand tools, measuring devices and torque values is also required.
- Include various precautions in the forms of Notes, Cautions, and Warnings. These are to assist in the assembly process and/or to draw attention to the fact that certain assembly steps may be dangerous and could cause serious personal injury and/or damage to components. Following the step-by-step procedures and these precautions should minimize the risk of any personal injury or damage to components while making the installation not only safe but an efficient process.

WARNING:
Follow the procedures and precautions in these instructions carefully.

Required Tools

- 7/16 inch wrench or socket for 1/4 inch module hardware
- 9/16 inch wrench or socket for 3/8 inch hardware
- 3/4 inch wrench or socket for 1/2 inch hardware
- 1-1/2 inch wrench or socket for 1 inch Pivot Bolt hardware
- Torque wrench
- Ratchet wrench
- Ratchet extension bar
- 3 to 6 foot level
- Tape Measure
- Square

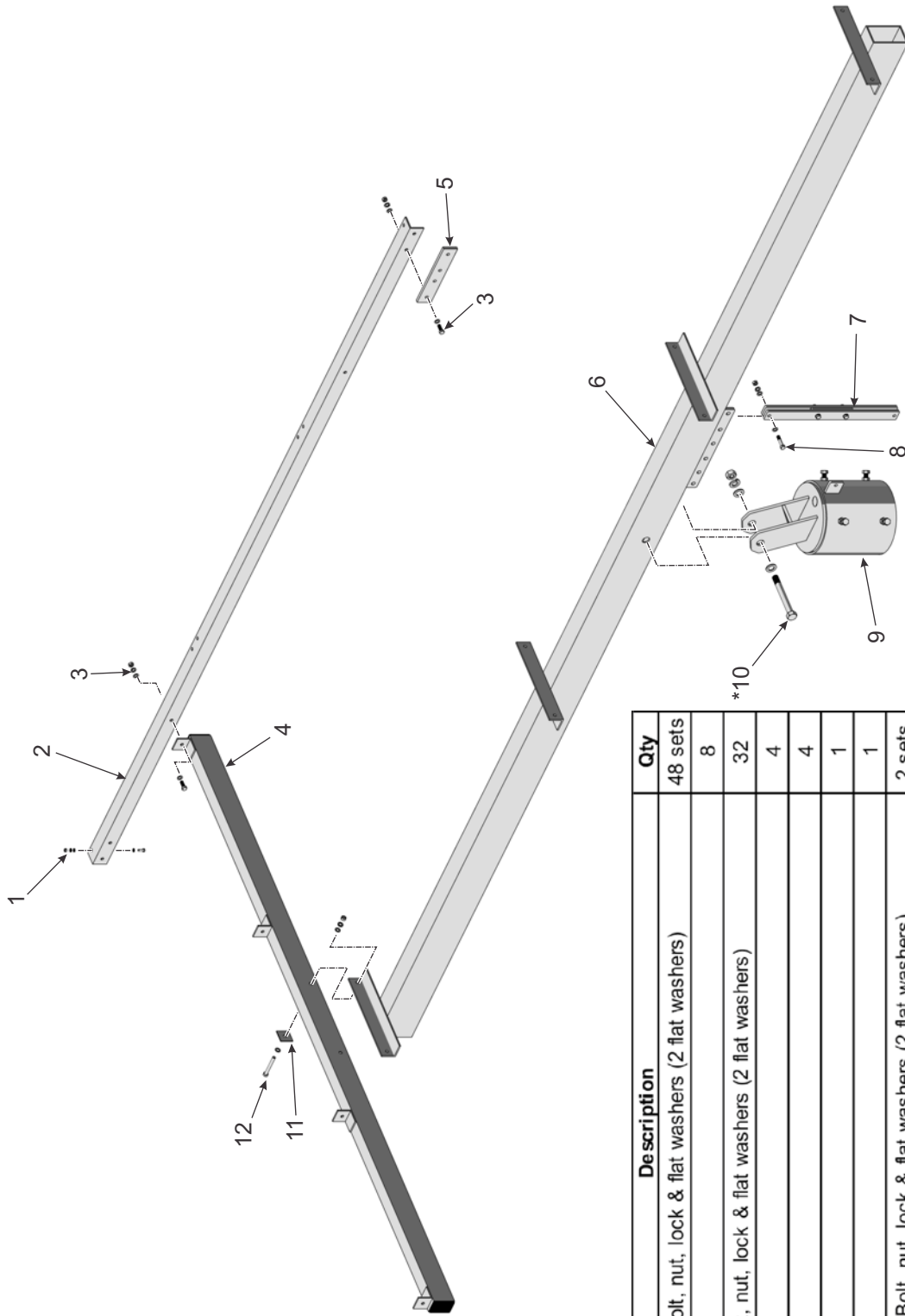

Item	Description	Qty
1	1/4" x 3/4" Bolt, nut, lock & flat washers (2 flat washers)	48 sets
2	Module Rail	8
3	3/8" x 1" Bolt, nut, lock & flat washers (2 flat washers)	32
4	Cross Bar	4
5	Splice Plate	4
6	Strongback	1
7	Support Bar	1
8	1/2" x 1 3/4" Bolt, nut, lock & flat washers (2 flat washers)	2 sets
9	Mounting Sleeve	1
10	1" x 5-1/2 or 6-1/2" Pivot Bolt, nut, lock & flat washers (2 flat washers)*	1 set
11	3/8" Square washer	8
12	3/8" x 3 1/4" Bolt, nut, lock & flat washers (2 flat washers)	8 sets

* Pivot Bolt length depends on the width of the Strongback width; as such a 3" wide Strongback uses a 5-1/2" Pivot Bolt and a 4" wide Strongback uses a 6-1/2" Pivot Bolt.

**Top-of-Pole Mount for 12 Modules for Module Types D, E, F, & G When High Wind Version (HWV)
or 6h x 2w, L Parts Identification**

CAUTION:

Use care while working around the structure during assembly. There could be components that create hazards or obstruct free movement causing serious bodily injury. Many are at head/eye level. Move slowly and with care around the work area.

Step 1: Install the Mounting Sleeve on Vertical Pipe

Before installing the Mounting Sleeve, verify that the Mounting Pole is plumb to the ground and hasn't shifted or leaned while the concrete footing has cured.

The Mounting Sleeve slips on top of the Mounting Pole and has four 1/2" Set Bolts which are used to secure it to the Mounting Pole. (See Figure 1-1)

- A. Slip the Mounting Sleeve on top of Mounting Pole and slide it down until it rests/bottoms out on top of Mounting Pole.
- B. Rotate the Mounting Sleeve so that the Support Bar Pivot Tab is pointing north and the Strongback Vertical Towers are leaning south.
- C. Secure the Mounting Sleeve by tightening the four 1/2" Set Bolts. **Torque each Set Bolt to 55-60 ft.-lbs.**

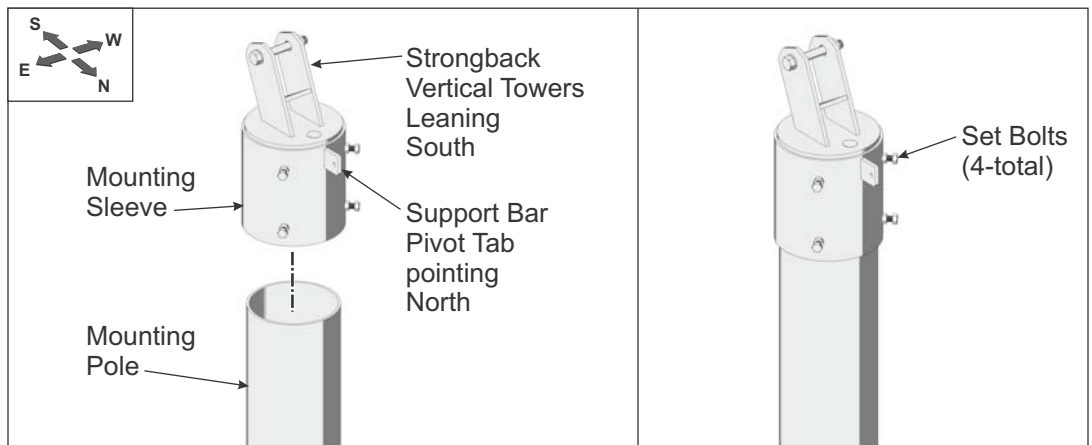

Figure 1-1: Installing the Mounting Sleeve

Step 2: Install the Strongback to the Mounting Sleeve

The Strongback is attached to the Mounting Sleeve using the Pivot Bolt that passes through its two Vertical Towers and the Support Bar. The Support Bar is attached to the Strongback on one end and the Support Bar Pivot Tab of the Mounting Sleeve on the other end using 1/2" hardware.

- A. Remove the Support Bar from the Strongback and re-install in the 15° elevation set point. Secure with the 1/2" hardware and finger tighten. (See Figure 2-1)

NOTE:

Although this system offers six elevation set points, for ease of assembly, set the angle to its lowest setting of 15-degrees. Optimum tilt setting of the rack will take place later in these instructions.

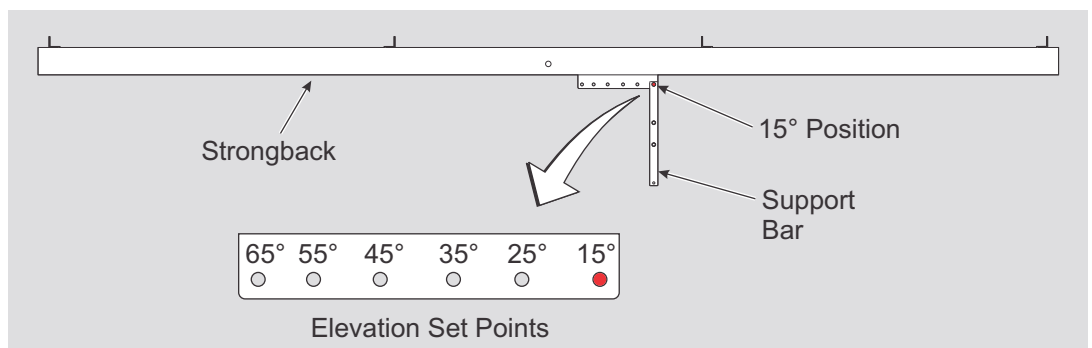

Figure 2-1: Positioning Support Bar

CAUTION:

This is a two person activity. The Strongback must be held in place by one person while the second person aligns it and secures it to the Mounting Sleeve using the Pivot Bolt and the 1" hardware. Failure to do so could lead to serious personal injury.

- B. Remove the Pivot Bolt from the Mounting Sleeve and collect the 1/2" x 1-3/4" bolt, nut, flat washers and lock washer needed to secure the Support Bar to its Pivot Tab on the Mounting Sleeve.
- C. Orient the Strongback to the Mounting Sleeve with its Lower Support Bar positioned on the same side of the Mounting Sleeve as the Support Bar Pivot Tab.
- D. Slide the Strongback between the two vertical mounting tabs, aligning the thru-hole of the Strongback with the holes of the two Vertical Towers.
- E. Insert the Pivot Bolt along with one flat washer through the one Vertical Tower and the Strongback exiting the second Vertical Tower on the opposite side. Secure with the remaining flat washer, lock washer and hex nut. For now, finger tighten only to allow movement for the next step.

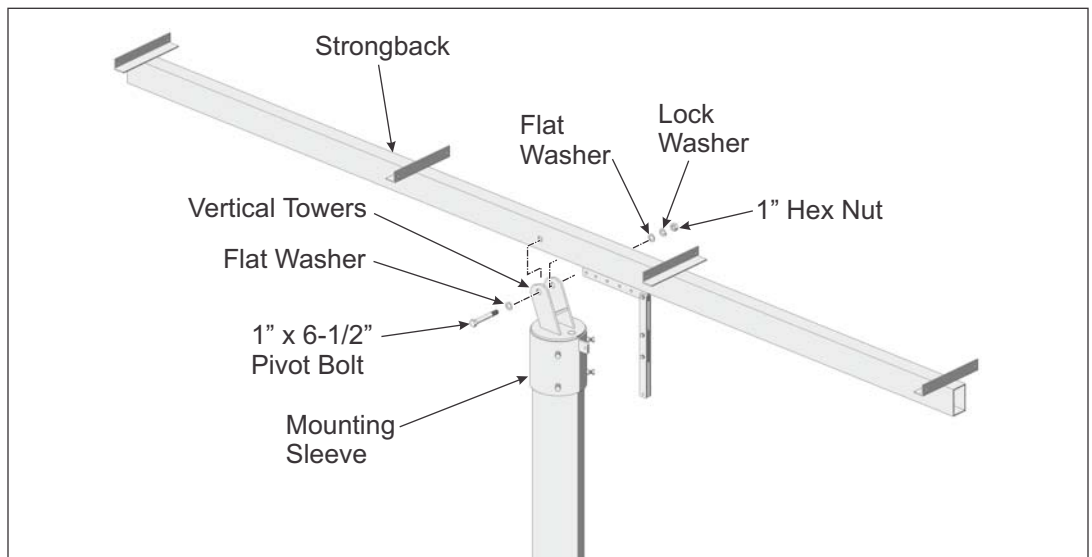

Figure 2-2: Installing the Strongback

- F. Pivot the Strongback and the Support Bar to align the mounting holes of the Support Bar with its Pivot Tab on the Mounting Sleeve. Slide the Support Bar over the Pivot Tab. Insert the 1/2" x 1-3/4" bolt and one flat washer thru the Support Bar and Mounting Tab and secure it with the remaining flat washer, lock washer and hex nut. **Torque hardware on both ends of Support Bar at 72-80 ft.-lbs.** (See Figure 2-3)

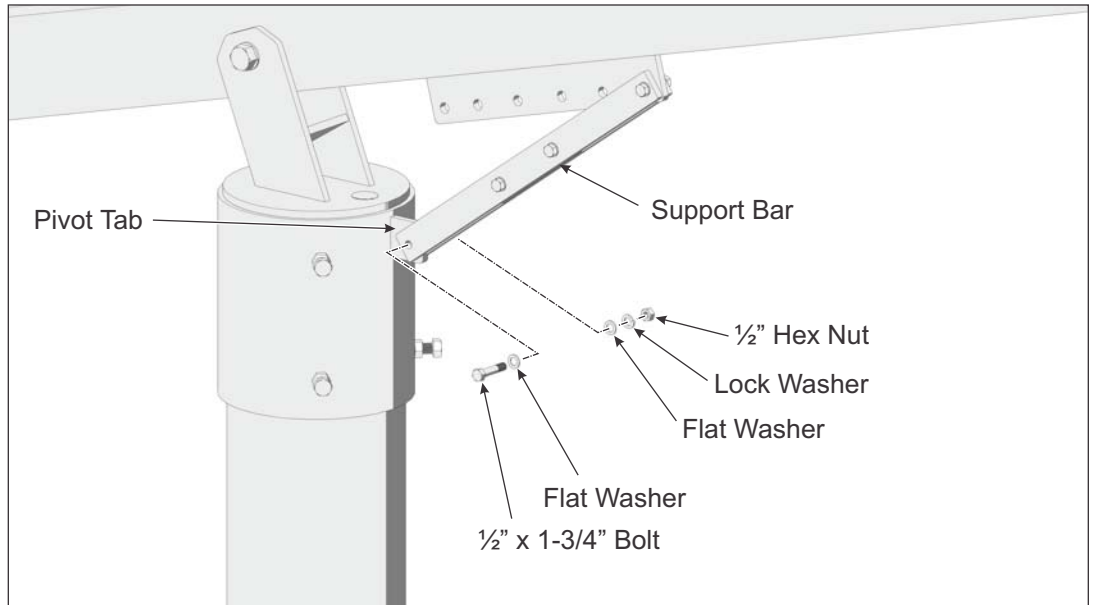

Figure 2-3: Securing Support Bar to Mounting Sleeve

G. Return and tighten the Pivot Bolt. The Pivot Bolt cannot be left loose - the Mounting Sleeve Vertical Towers must be firmly clamped to the sides of the Strongback eliminating any gaps between the Vertical Towers and the Strongback. **Torque to 330-350 ft.-lbs.** (See Figure 2-4)

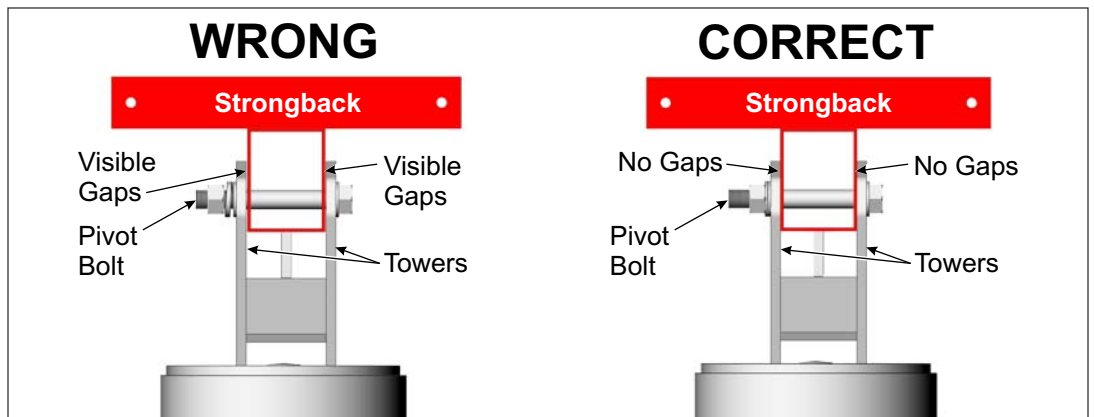

Figure 2-4: Tighten and Torque the Pivot Bolt

WARNING:

This is a two person activity. Cross-Bars are unstable before they are fully secured to the Strongback. Cross-Bars must be held in place by one person while the second person aligns and secures them to the Strongback. Failure to do so could lead to personal injury.

Step 3: Install the Cross-Bars to the Strongback

Cross-Bars run in an E-W direction and are secured to the mounting angles (welded to the Strongback) using 3/8" square flat washers along with 3/8" x 3-1/4" bolts and hardware. There are four Cross-Bars to install.

Cross-Bars are mounted to the outside of the Strongback mounting angles (these are welded to the Strongback); they are not nested into the Mounting Angles. (See Figures 3-1 and 3-2)

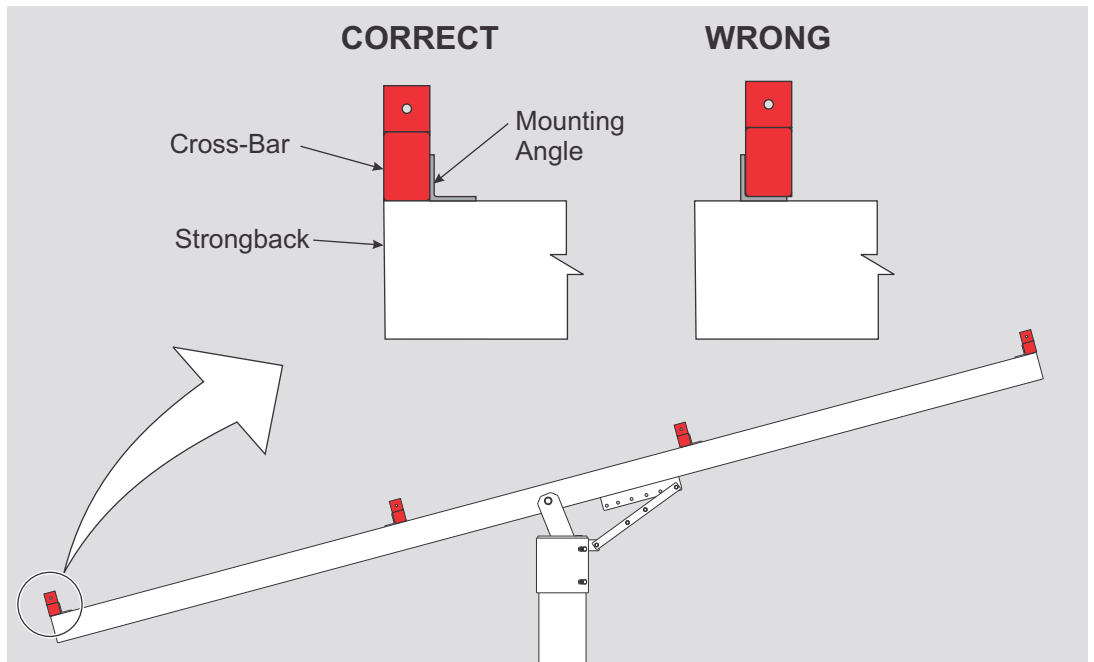

Figure 3-1: Orientation of Cross-Bars to Strongback

Installing the Cross-Bars.

- A. Starting at the south location, position the Cross-Bar on the outside of the mounting angle of the Strongback. Align the mounting holes and secure using 3/8" flat and square washers along with the 3/8" x 3-1/4" bolts and lock washer placing the square flat washer against the Cross-Bar. Tighten hardware and **Torque to 30-32 ft.-lbs.** (See Figure 3-2)
- B. Continue in this manner and install the remaining three Cross-Bars to the Strongback. Refer to Figure 3-2 as needed for proper positioning.

CAUTION:

Be sure to place the 3/8" square washers on the surface of the Cross-Bar and not the Mounting Angles of the Strongback. Failure to do so will damage the surface of the Cross-Bar when the attaching hardware is tightened.

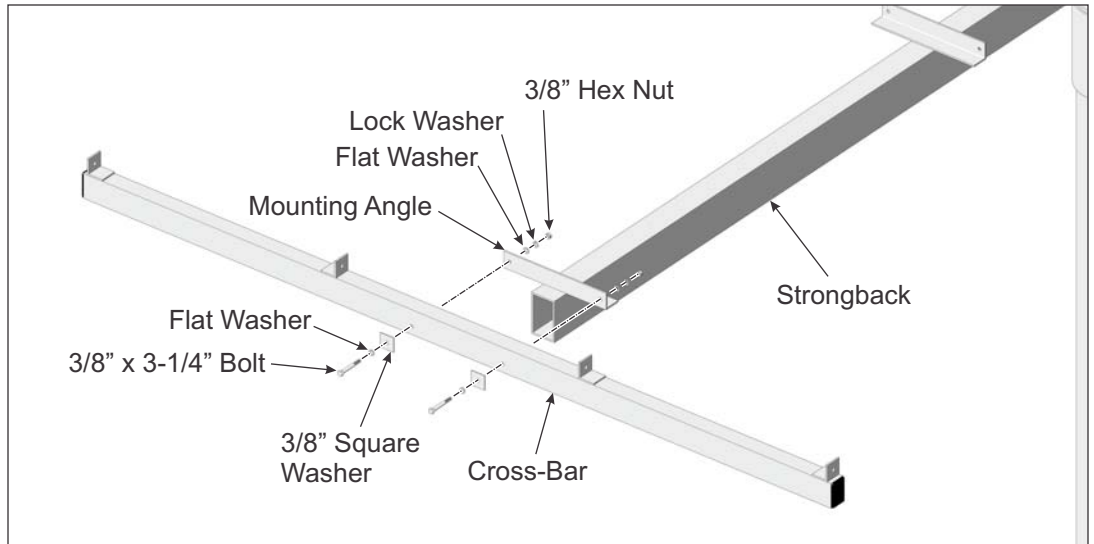

Figure 3-2: Installing Cross-Bars to Strongback

Step 4: Install the Module Rails to the Cross-Bars

Module Rails run in an N-S direction and are secured to the mounting tabs of the Cross-Bars (these are welded to the Cross-Bars) using 3/8" x 1" bolts and hardware. There are twelve Module Rails to install.

There are four locations on the Cross-Bars where Module Rails are attached; at each of these locations two Rails are installed and butt jointed using Splice Plates. Splice Plates are positioned on the outside of the Module Rails (See Figure 4-1) and secured using 3/8" x 1" bolts and hardware. There are four Splice Plates to install.

Additionally, Module Rails are installed differently depending on where they are located on the Cross-Bars and the orientation of the mounting tabs of the Cross-Bars. Follow these instructions carefully for the correct orientation. (See Figure 4-2)

NOTE:

Be certain that the orientation of the Cross-Bars to the Strongback match these instructions.

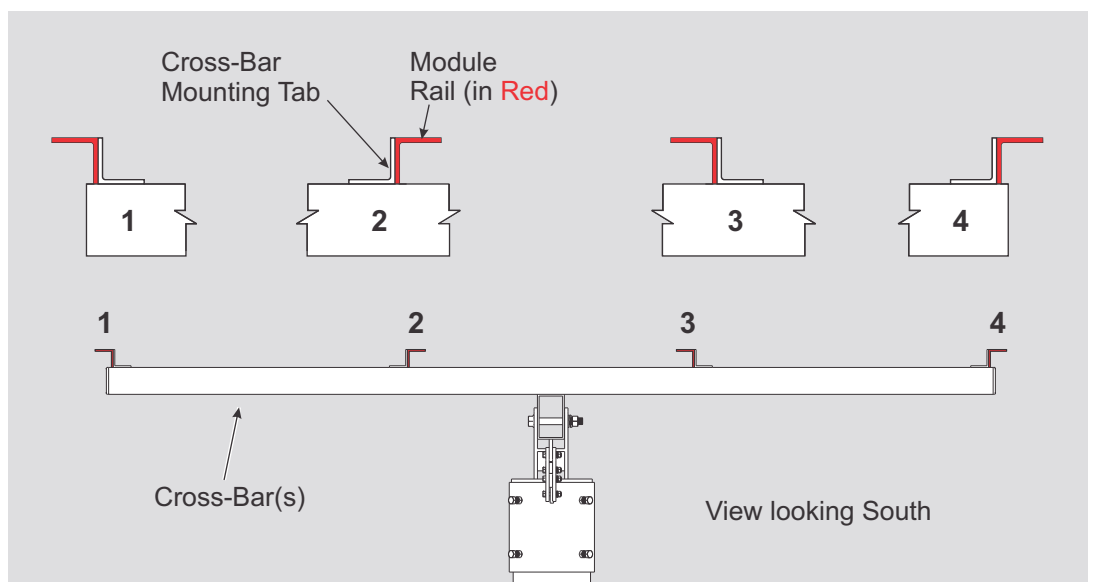

Figure 4-1: Orientation of Module Rails to Cross-Bars

Start by installing the inboard sections of Module Rail first and work outward.

- A. Referring to Figure 4-1 for orientation of the Module Rails, position the first section of inboard Module Rail in the southern position on the Cross-Bars. Align the Module Rail mounting holes with the holes of the Cross-Bar mounting tabs and secure with 3/8" x 1" bolts and hardware. Finger-tighten for now. (See Figure 4-2)

NOTE:
Finger-tighten the Rail Angles to the Strongback while installing. After PV Modules are installed go back and tighten to specified torque values.

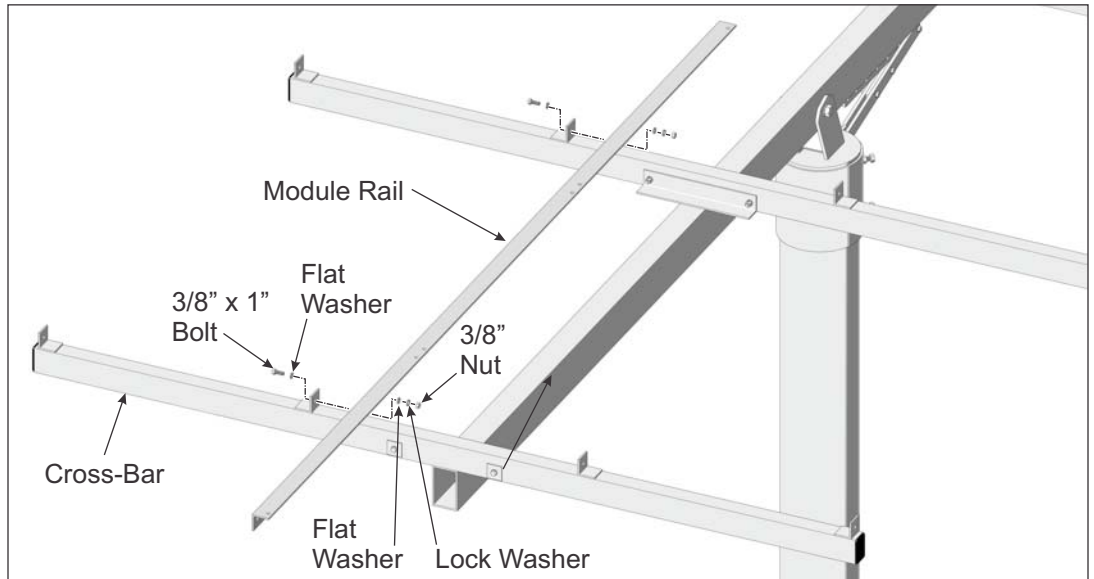

Figure 4-2: Installing southern inboard Module Rail to Cross-Bars

- B. Next, install the northern Module Rail creating a butt-joint with the previously installed Module Rail. Align the Module Rail mounting holes with the holes of the Cross-Bar mounting tabs and secure with 3/8" x 1" bolts and hardware. Finger-tighten for now. (See Figure 4-3)

NOTE:
Double check the orientation of inboard to outboard Module Rails. If they are installed differently from these instructions the mounting holes will not align to the holes of the PV Modules.

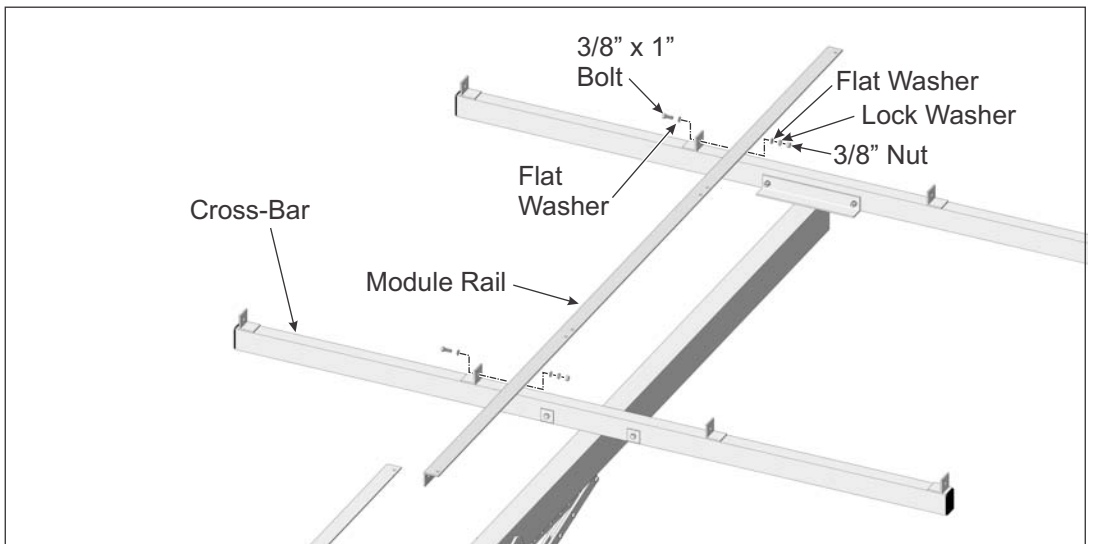

Figure 4-3: Installing northern inboard Module Rail to Cross-Bars

- C. Install a Splice Plate at butt-joint of the two Module Rails. Align the four holes of the Splice Plate with the four holes (two on each end of the Module Rails) of the Rails and secure with 3/8" hardware. **Torque to 32-34 ft.-lbs.** (See Figure 4-4)

Continue in this manner and install all remaining Module Rails (six more) while being mindful and following Figure 4-1 for proper orientation of the Rails to the Cross-Bar mounting tabs.

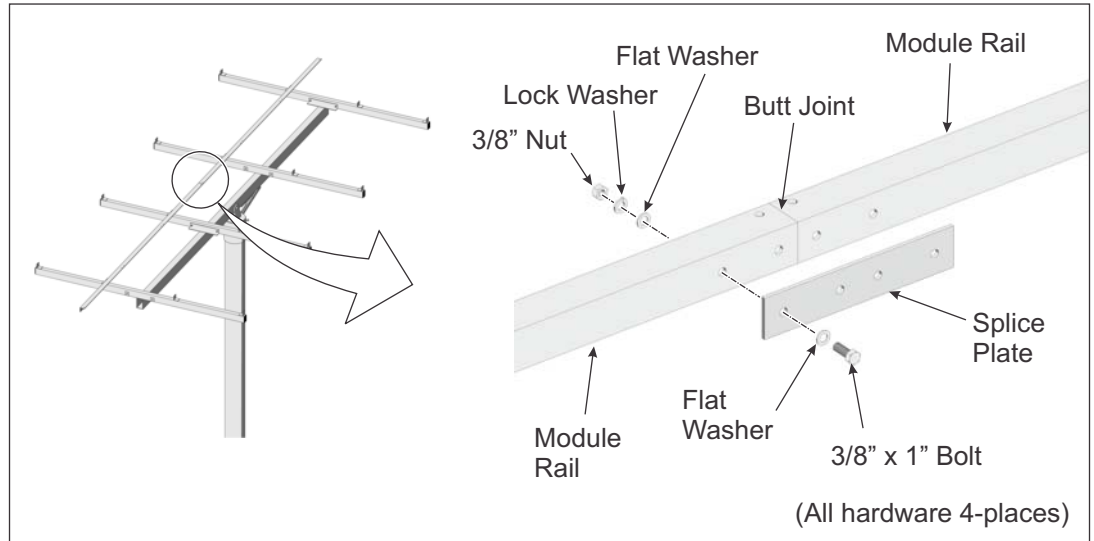

Figure 4-4: Attaching the Splice Plate to Module Rails

Step 5: Installing PV Modules to Module Rails

PV Modules are secured to the Module Rails using 1/4" x 3/4" bolts and hardware.

- Place an interior PV Module on the Module Rails. Align the mounting holes and secure with 1/4" x 3/4" bolts and hardware; each Module has four attachment points. Finger-tighten for now. (See Figure 5-1)
- Continue in this manner to install all interior PV Modules first and then work in a outward direction installing the remaining Modules.

CAUTION:
This is a two person activity. PV Modules are heavy and unstable before they are fully secured to the Module Rails. PV Modules must be held in place by one person while the second person aligns and secures them to the Module Rails. Failure to do so could lead to serious personal injury and damaged components.

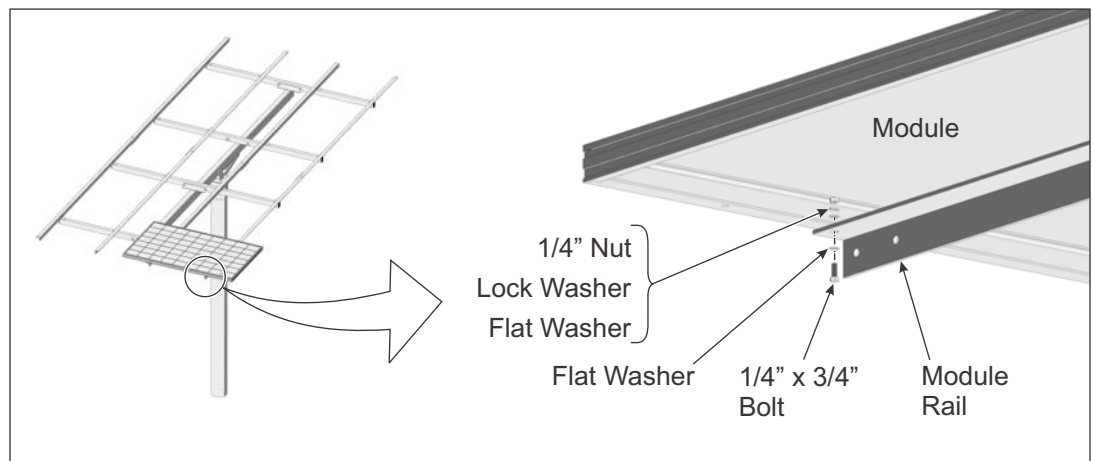

Figure 5-1: Installing PV Modules to Module Rails

Step 6: Now return and tighten mounting hardware.

- A. Return and tighten each set of the 3/8" mounting hardware, securing the Module Rails to the Cross-Bars. **Torque all at 32-34 ft.-lbs.**
- B. Return and tighten each set of 1/4" mounting hardware, securing the PV Modules to the Module rails. **Torque all at 6-8 ft.-lbs.**

Step 7: Adjust the Tilt Angle of the Rack

To adjust the tilt angle, loosen the Pivot Bolt hardware and removing the upper hardware attaching Tubular Support Arm to the Strongback. Use great care in this procedure as it can be dangerous if the procedure is not completed as described with a minimum of two people. (See Figures 7-1 and 7-2)

- A. While one person holds the south edge of rack, the other loosens the Pivot Bolt and removes the upper 1/2" hardware attaching the Support Bar to the Strongback.

WARNING:

Do not attempt to remove the Pivot Bolt during tilt adjustments! Removal could lead to serious personal injury or death. Adjustments are made with the Pivot Bolt hardware loosened but in place.

CAUTION:

This is a two person activity. As the Pivot Bolt is loosened and the Tubular Support Bar hardware is removed, the rack is heavy and unstable. The rack must be held in place by one person while the second person loosens and removes the hardware and then re-installs/tightens the hardware back in place. Failure to do so could lead to serious personal injury and damaged components.

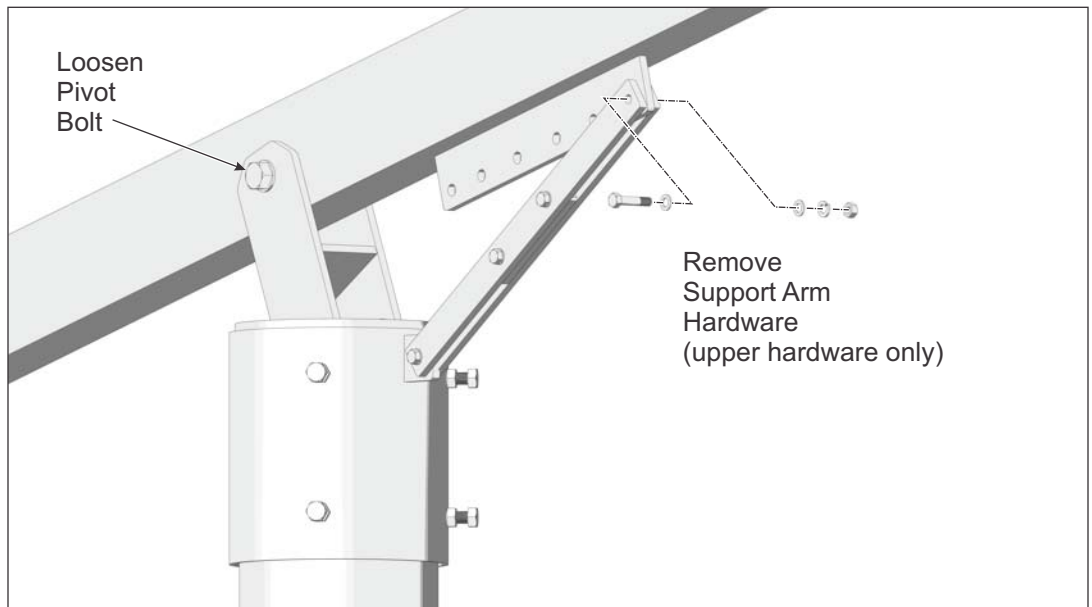

Figure 7-1: Preparing to Adjust the Tilt Angle

- B. Tilt the rack to the desired elevation angle (15°, 25°, 35°, 45°, 55°, or 65°) and re-attach the Support Bar to the Strongback placing the 1/2" hardware in the appropriate hole matching the desired elevation. **Torque to 72-80 ft.-lbs.**

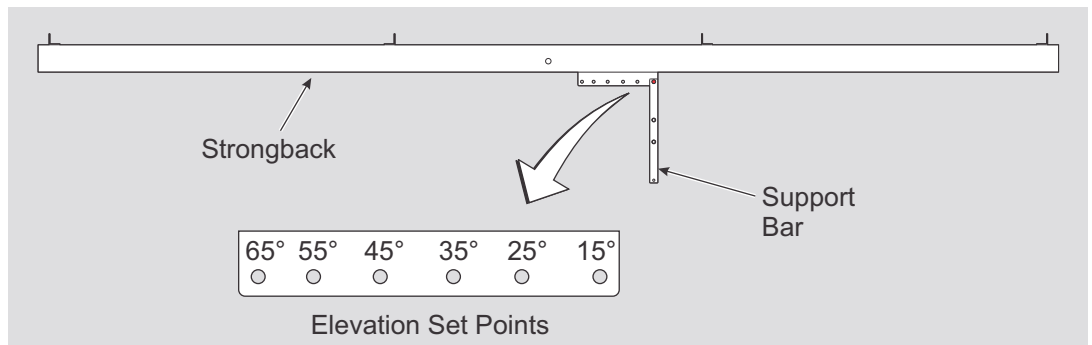

Figure 7-2: Setting the Tilt Angle

CAUTION:

Be certain to re-tighten all Rail Angle, Module Rail and PV Module mounting hardware and torque to the specified values. Failure to do so could lead to structural failure, damaged components and/or serious personal injury.

- C. Re-tighten the Pivot Bolt. After changing the tilt angle and tightening the Support Bar hardware, the Pivot Bolt must be re-tightened. The Pivot Bolt cannot be left loose - the Mounting Sleeve Vertical Towers must be firmly clamped to the sides of the Strongback, eliminating any gaps between the Vertical Towers and the Strongback. **Torque to 330-350 ft.-lbs.** (See Figure 7-3)

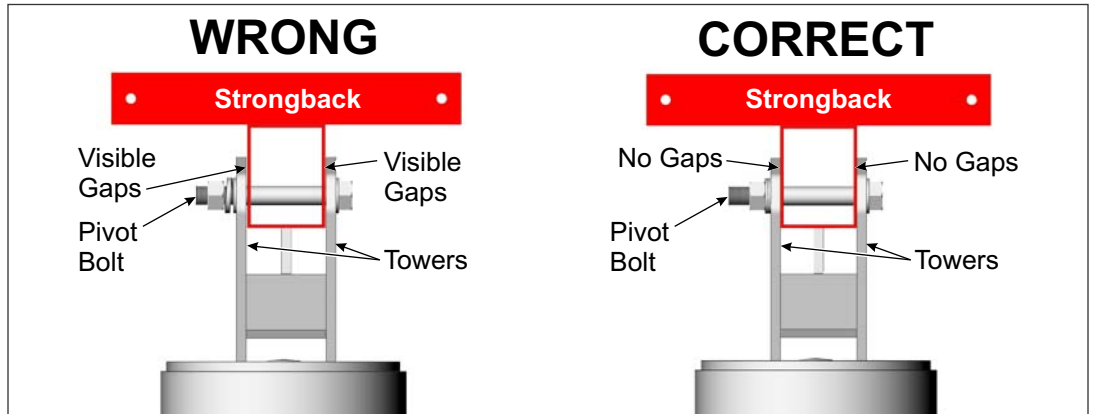

Figure 7-3: Tighten and Torque the Pivot Bolt



2716 Vassar Place NE
Albuquerque, New Mexico 87107
USA

Telephone: 800.260.3792
Fax: 505.889.3548
Web Site: www.DPWSolar.com
E-mail: info@dpwsolar.com

Preformed Line Products
(Canada) Limited
1711 Bishop St. E
Cambridge, ON N1T 1N5

Telephone: 519.740.6666
Fax: 519.740.7917
Web Site: www.preformed.on.ca
E-mail: sales@preformed.on.ca