



DPW | SOLAR



PREFORMED LINE PRODUCTS



Side-of-Pole Mount for 1 Module (SPM1) For Module Types A & B

ASSEMBLY INSTRUCTIONS

**step-by-step
assembly and installation**

Side-of-Pole Mount for 1 Module (SPM1) For Module Types A & B

A few words about the product

The SPM1 for module types A & B is designed to mount on 2”- 3.5” O.D. pipe (installer supplied). Options are available for mounting to larger diameter poles.

Pipe size and foundation requirements are based on several factors including the array surface area, maximum design wind speed, exposure category, soil type, steepest expected tilt angle, and above-ground clearance.

For foundation and pipe size recommendations on a specific installation please contact us at:

Phone: 800-260-3792

Email: info@dpwsolar.com

About these Assembly Instructions

These instructions...

- Are intended to be used by individuals with sufficient technical skills for the task. Knowledge and use of hand tools, measuring devices and torque values is also required.
- Include various precautions in the forms of Notes, Cautions, and Warnings. These are to assist in the assembly process and/or to draw attention to the fact that certain assembly steps may be dangerous and could cause serious personal injury and/or damage to components. Following the step-by-step procedures and these precautions should minimize the risk of any personal injury or damage to components while making the installation not only safe but an efficient process.

WARNING:

Follow the procedures and precautions in these instructions carefully.

Required Tools

- 7/16 inch wrench or socket for 1/4 inch module hardware
- 1/2 inch wrench or socket for 5/16 inch hardware
- 9/16 inch wrench or socket for 3/8 inch hardware
- Torque wrench (not absolutely necessary)
- Ratchet wrench
- Ratchet extension bar
- 3 to 6 foot level
- Tape Measure
- Square

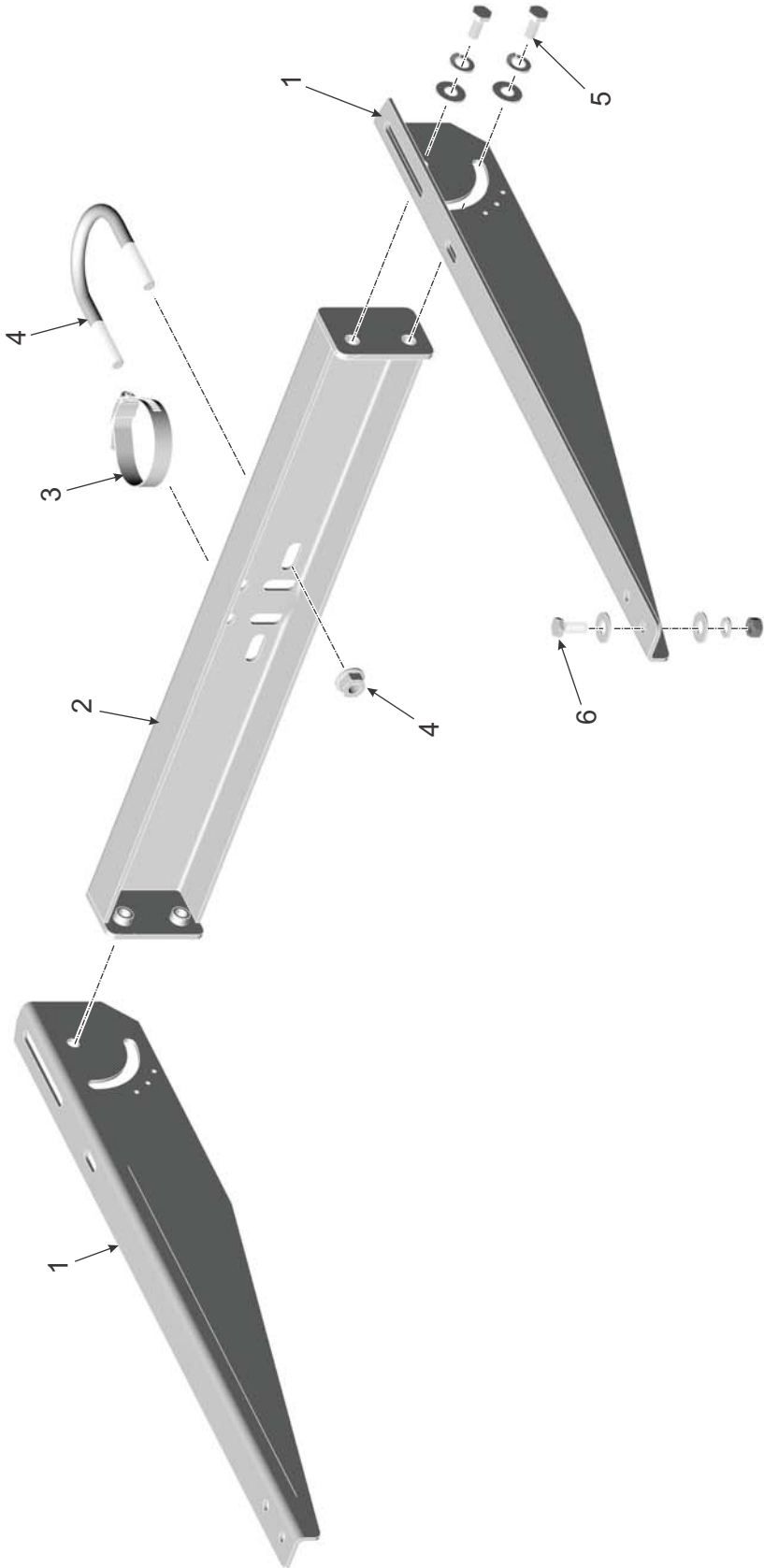

Item	Description	Qty
1	Module Arm, Left & Right	1 set per Rack
2	Pole Channel	1 per Rack
3	Hose Clamp (standard)	2 per Rack
4	3/8" U-Bolt, flange nut (optional)	2 per Rack
5	5/16" x 3/4" hex bolt, lock washer, flat washer	4 sets per Rack
6	1/4" x 3/4" hex bolt, lock washer, flat washers, nut	4 sets per Rack

Side-of-Pole Mount for 1 Module for Module Types A & B Parts Identification

CAUTION:

Use care while working around the structure during assembly. There could be components that create hazards or obstruct free movement, causing serious bodily injury. Many of these are at head/eye level. Move slowly and with care around the work area.

Step 1: Attach Pole Channel to Mounting Pole

Before installing the Pole Channel, verify that the Mounting Pole is plumb to the ground and hasn't shifted or leaned while the concrete footing has cured.

There are two methods to attaching the Pole Channel to the Mounting Pole. The only difference between the two methods is the hardware. One uses Hose Clamps while the other uses U-Bolts. These racks are supplied with hose clamps. U-Bolts are available at extra cost and the pole diameter must be specified.

Using Hose Clamps

Hose Clamps pass through the two sets of vertical slotted holes of the Pole Channel, securing it to the Mounting Pole. See site specific drawings for vertical placement of the Pole Channel on the Mounting Pole.

- A. Unscrew the two Hose Clamps and pass the loose ends through the two vertical slots of the Pole Channel, positioning the screw housing on the backside of the Pole Channel. Secure the loose end by screwing them back into their screw housing. (See Figure 1-1)

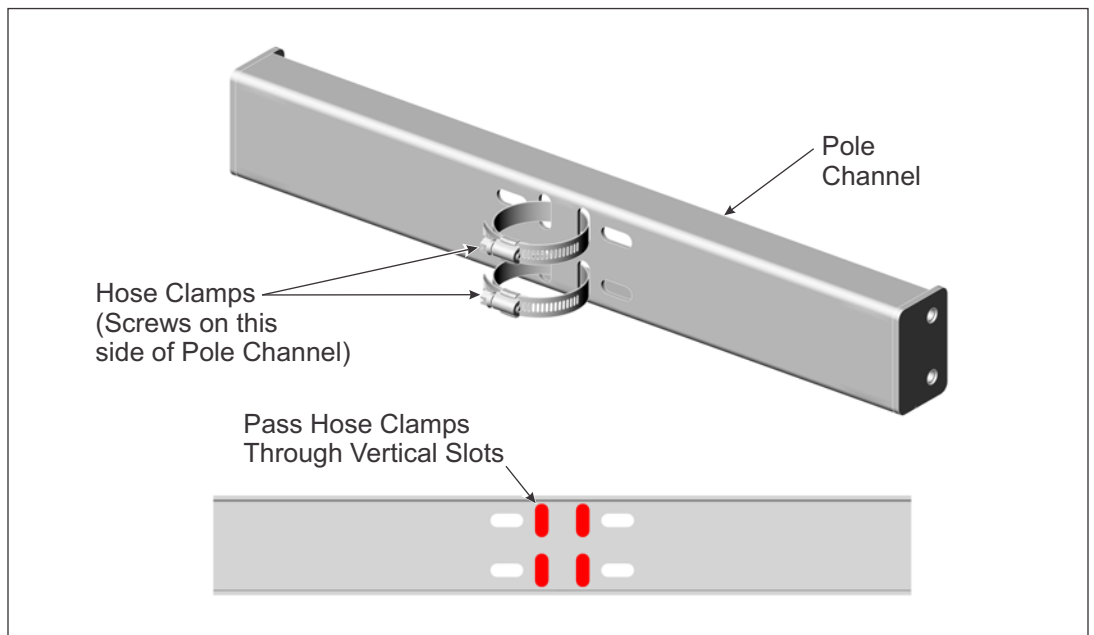

Figure 1-1: Installing Hose Clamps on Pole Channel

- B. Slip the Hose Clamps and Pole Channel over the top of Mounting Pole, sliding it down to its pre-determined vertical position on the Mounting Pole.
- C. Rotate the Pole Channel so it is facing south. (See Figure 1-2)
- D. Tighten the two Hose Clamps securing it to the Pole Channel.

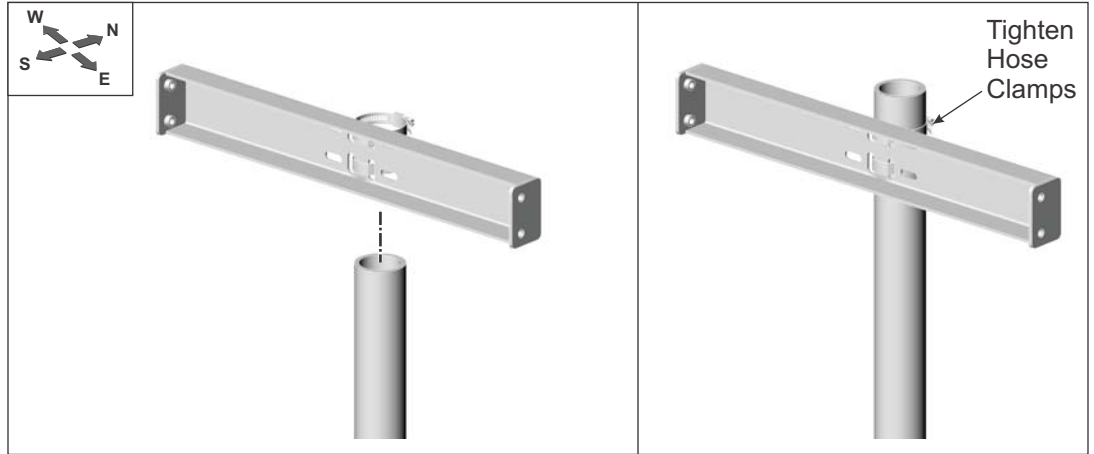

Figure 1-2: Installing Pole Channel

Using U-Bolts (option)

U-Bolts pass through the two sets of horizontal slotted holes of the Pole Channel, securing it to the Mounting Pole. See site specific drawings for vertical placement of the Pole Channel on the Mounting Pole.

- A. Pass the two U-bolts through the two horizontal slotted holes of the Pole Channel and finger tighten.
- B. Rotate the Pole Channel so it is facing south. (See Figure 1-3)
- C. Tighten the four 3/8" flange nuts. **Torque to 25-30 ft.-lbs.**

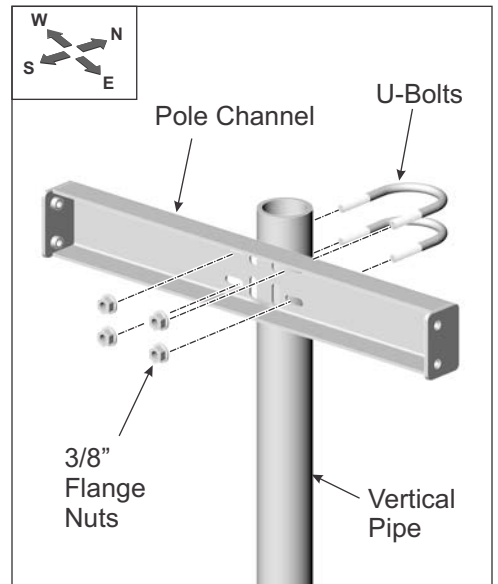

Figure 1-3: Installing U-Bolts

Step 2: Attaching Module Arms to Pole Channel

The Module Arms are attached to the ends of the Pole Channel using 5/16" x 3/4" hex bolts and hardware. Module Arms are left and right hand configurations, keep this in mind during the installation. Figure 2-1 shows the installation of a right-hand Module Arm, installing a left-hand installation mirrors that shown.

- A. Orient and align the Module Arm as shown in Figure 2-1. Secure the Module Arm by inserting two 5/16" x 3/4" hex bolts with lock washers and flat washers, through the Module Arm and into the threaded inserts of the Pole Channel. To facilitate the module installation, position the Module Arm at 0-degrees as shown in Figure 2-1. **Torque to 25-30 ft.-lbs.**
- B. Continue in this manner and install the left Module Arm.

NOTE:

Although this system offers a range of elevation settings, it is recommended to set the angle at 0-degrees for ease of assembly. Optimum tilt setting of the rack will take place later in these instructions.

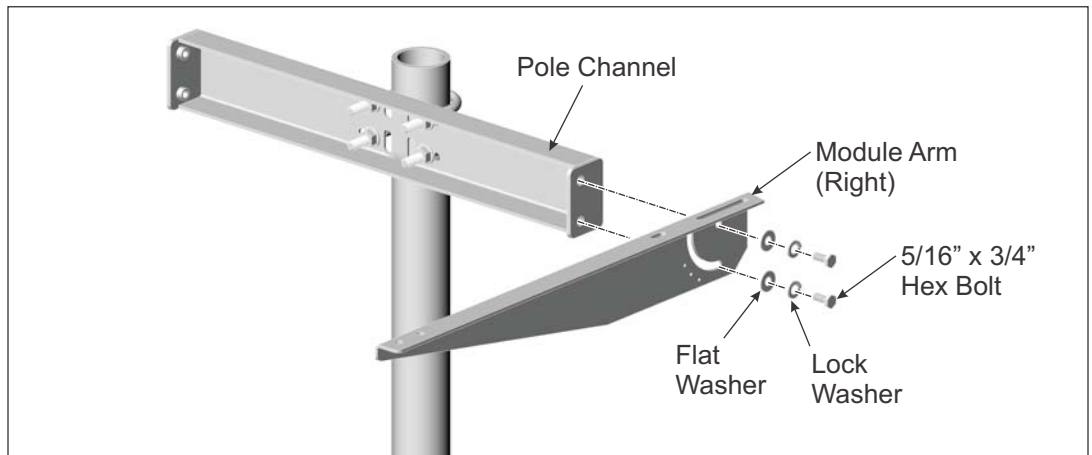

Figure 2-1: Attaching Module Arm to Pole Channel

Step 3: Installing PV Modules to Module Rails

PV Modules are secured to the Module Arms using 1/4" x 3/4" bolts and hardware.

- A. Place the Module on the Module Arms. While one person holds the Module in place, align the mounting holes and secure with 1/4" x 3/4" bolts and hardware. Each Module has four attachment points. **Torque to 6-8 ft.-lbs.** (See Figure 3-1)

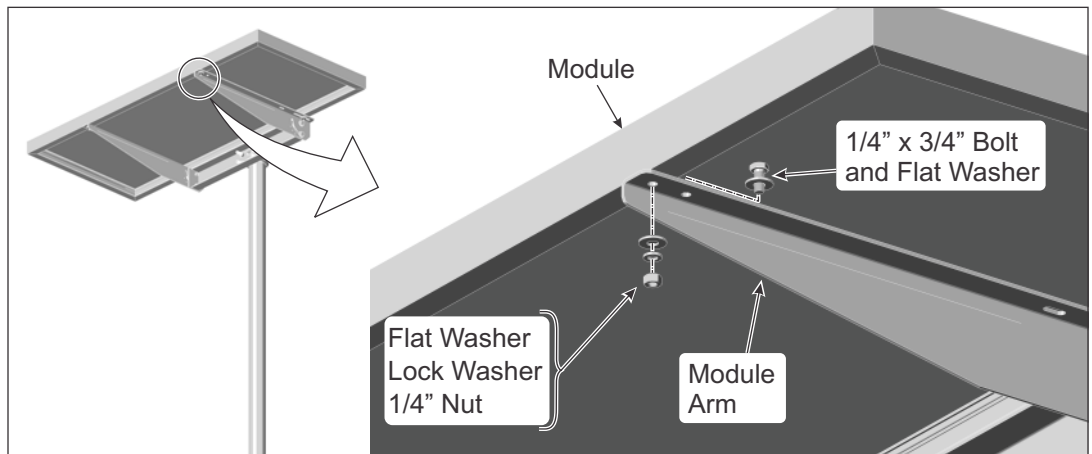

Figure 3-1: Attaching Module to Module Arm

CAUTION:

This is a two person activity. PV Modules are heavy and unstable before they are fully secured to the Module Arms. The PV Module must be held in place by one person while the second person aligns and secures them to the Module Arms. Failure to do so could lead to serious personal injury and damaged components.

Step 4: Set the Tilt Angle

CAUTION:

This is a two person activity. As the 5/16" hardware is loosened, the Module is heavy and unstable. It must be held in place by one person while the second person loosens and then re-tightens the hardware back in place. Failure to do so could lead to serious personal injury and damaged components.

Use great care as it can be dangerous if the procedure is not done as described and done with a minimum of two people. Adjust the tilt angle by loosening the four 5/16" bolts securing the Module Arms to the Pole Channel. Do not remove this hardware, simply loosen it to facilitate the movement of the Module

- A. While one person holds the south edge of Module, the other loosens the four 5/16" bolts. (see Figure 4-1)
- B. Tilt the Module to the desired elevation angle. Re-tighten the four 5/16" bolts. **Torque to 14-16 ft.-lbs.**

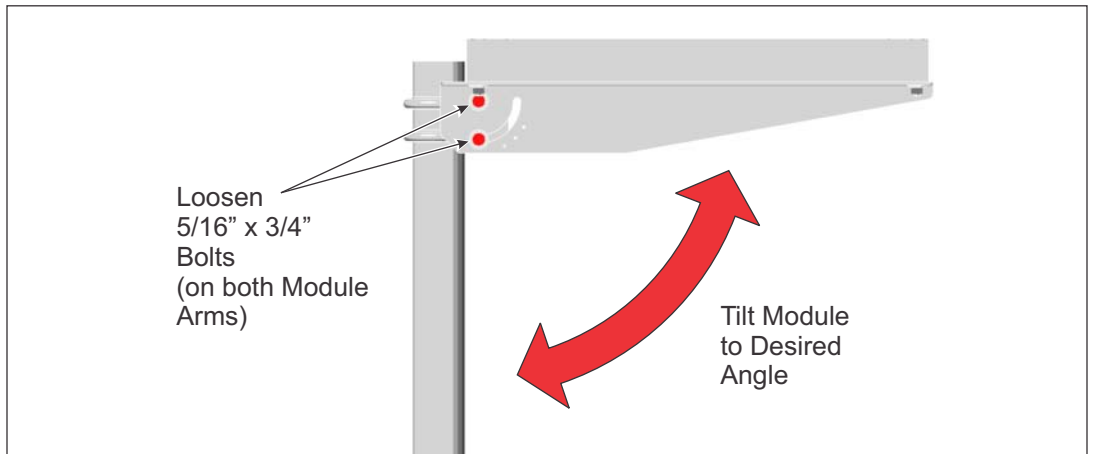

Figure 4-1: Adjusting the Tilt Angle



DPW Solar
2716 Vassar Place NE
Albuquerque, New Mexico 87107
USA

Telephone: 800.260.3792
Fax: 505.889.3548
Web Site: www.DPWSolar.com
E-mail: info@dpwsolar.com

Preformed Line Products
(Canada) Limited
1711 Bishop St. E
Cambridge, ON N1T 1N5

Telephone: 519.740.6666
Fax: 519.740.7917
Web Site: www.preformed.on.ca
E-mail: sales@preformed.on.ca