

Universal Top-of-Pole Mount 10 Modules (UTPM10) Module Type G

Assembly Instructions

**step-by-step
assembly and installation**

SAFETY CONSIDERATIONS

This application procedure is not intended to supersede any company construction or safety standards. This procedure is offered only to illustrate safe application for the individual.

FAILURE TO FOLLOW THESE PROCEDURES MAY RESULT IN PERSONAL INJURY OR DEATH.

Do not modify this product under any circumstances, except where noted in this application procedure.

This product is intended for use by trained technicians only.

This product should not be used by anyone who is not familiar with, and not trained to use it.

When working in the area of energized lines, extra care should be taken to prevent accidental electrical contact. Be sure to wear proper safety equipment per your company protocol.

For proper performance and personal safety, be sure to select the proper size PREFORMED™ product before application.

PREFORMED products are precision devices. To ensure proper performance, they should be stored in cartons under cover and handled carefully.

Universal Top-of-Pole Mount For 10 Modules (UTPM10) For Module Type G

WARNING

Follow the procedures and precautions in these instructions carefully.

About the product

The UTPM10 for module Type G is designed for a wide range of Module size, from 37-42" in width to 61-67" in length. The Universal Top-of-Pole support structure mounts on 8-inch SCH40/80 galvanized steel pipe (installer supplied). Pipe size and foundation requirements are based on several factors including the array surface area, maximum design wind speed, exposure category, soil type, steepest expected tilt angle, and above-ground clearance.

For foundation and pipe size recommendations on a specific installation, visit:

Preformed.com and select the TPM online configurator tool.

Or contact us directly at:

Phone: 800-260-3792
Email: info@plpsolar.com

About these instructions:

- These instructions are intended to be used by individuals with sufficient technical skills for the task. Knowledge and use of hand tools, measuring devices and torque values is also required.
- These instructions include various precautions in the forms of Notes, Cautions, and Warnings. These are to assist in the assembly process and/or to draw attention to the fact that certain assembly steps may be dangerous and could cause serious personal injury and/or damage to components. Following the step-by-step procedures and these precautions should minimize the risk of any personal injury or damage to components while making the installation not only safe but an efficient process.

Periodic Inspection

Periodic re-inspection is a recommended system maintenance procedure to check for any loose components and any corrosion. If any loose components and any corrosion is found, the affected components are required to be replaced immediately, with the original mounting system manufacturer's component parts.

Required Tools

- 7/16 inch wrench or socket for 1/4 inch module hardware
- 9/16 inch wrench or socket for 3/8 inch module hardware
- 3/4 inch wrench or socket for 1/2 inch module hardware
- 1-1/8 inch wrench or socket for 3/4 inch pivot bolt hardware
- Torque wrench
- Ratchet wrench
- Ratchet extension bar
- Tape Measure
- Square

UTPM10 Type G Main Components

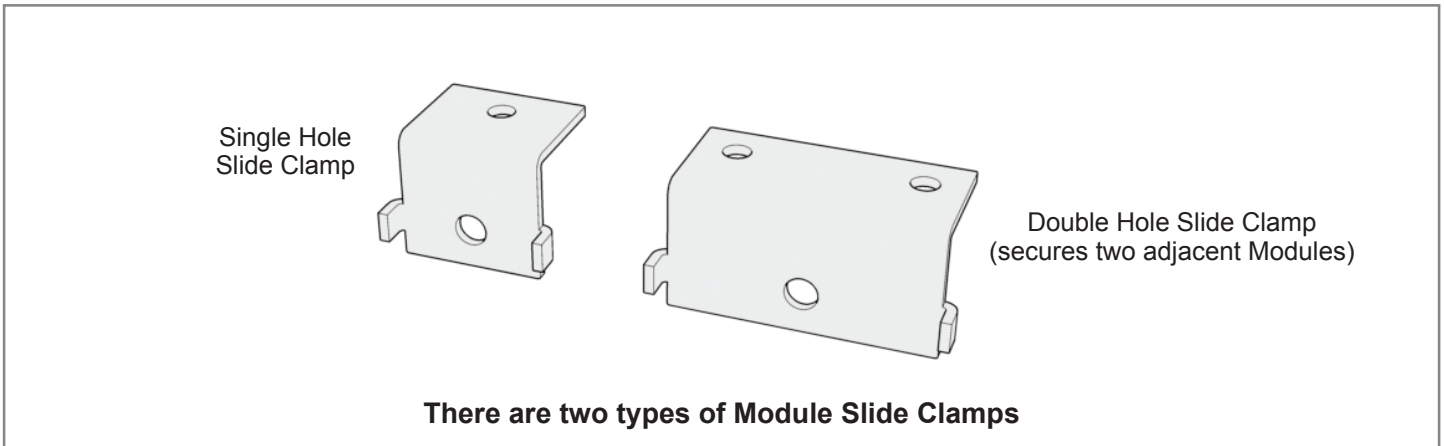
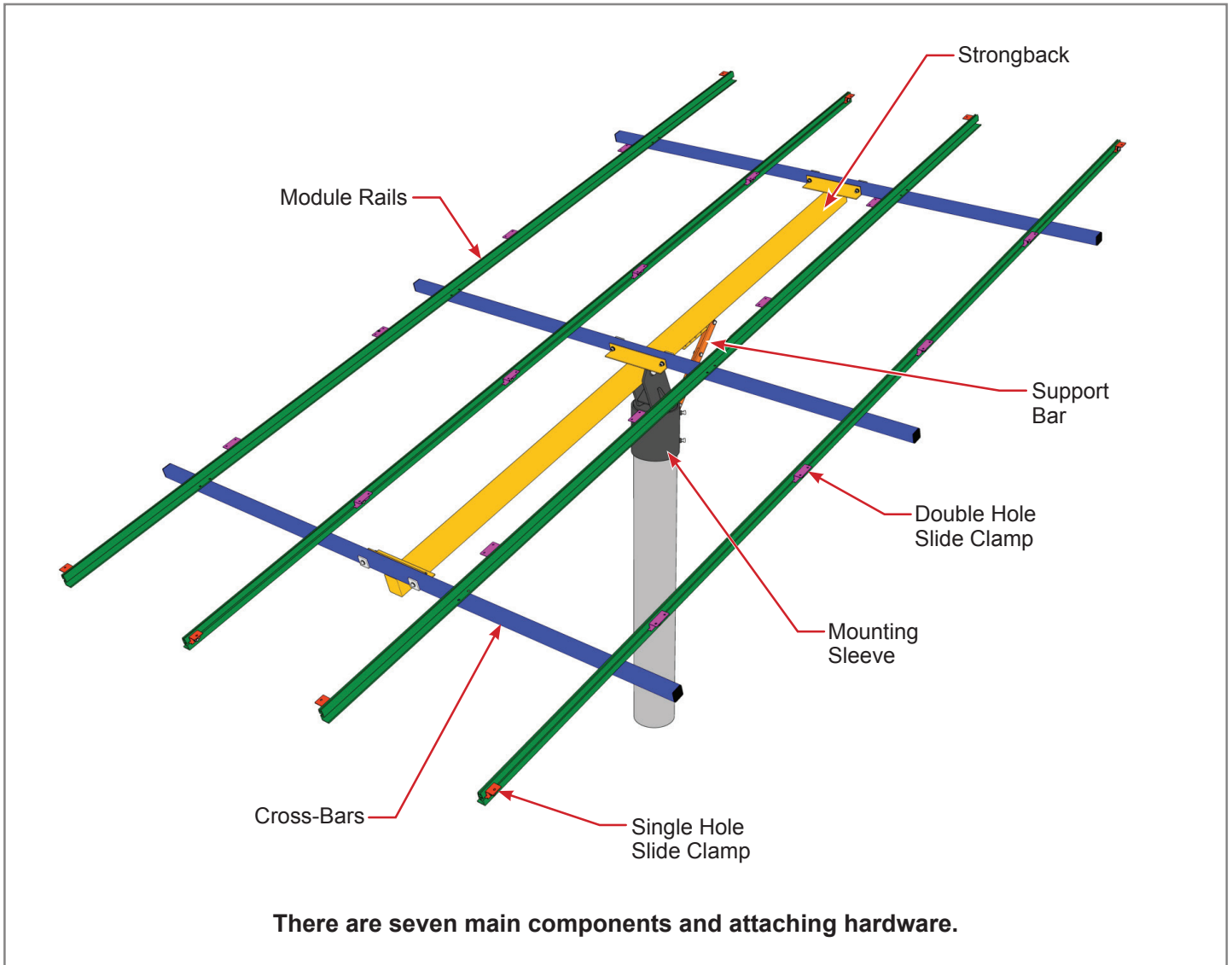

Universally adjustable to accommodate a range of PV Module sizes

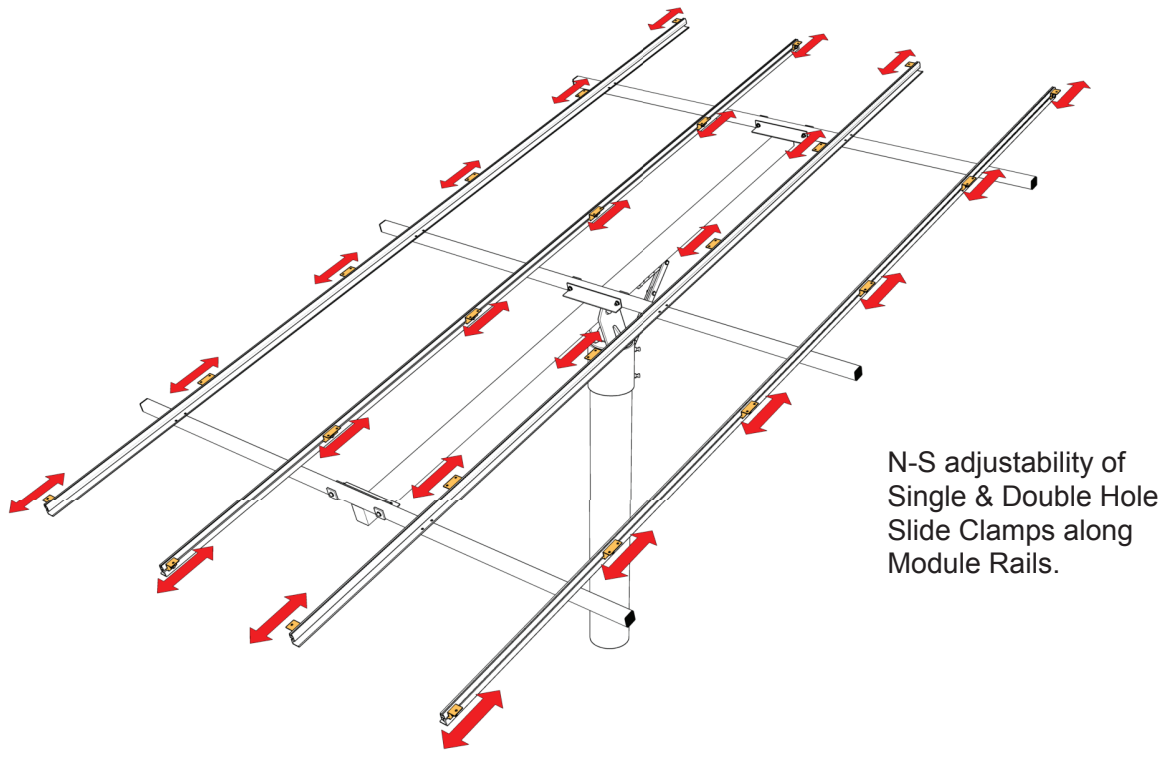
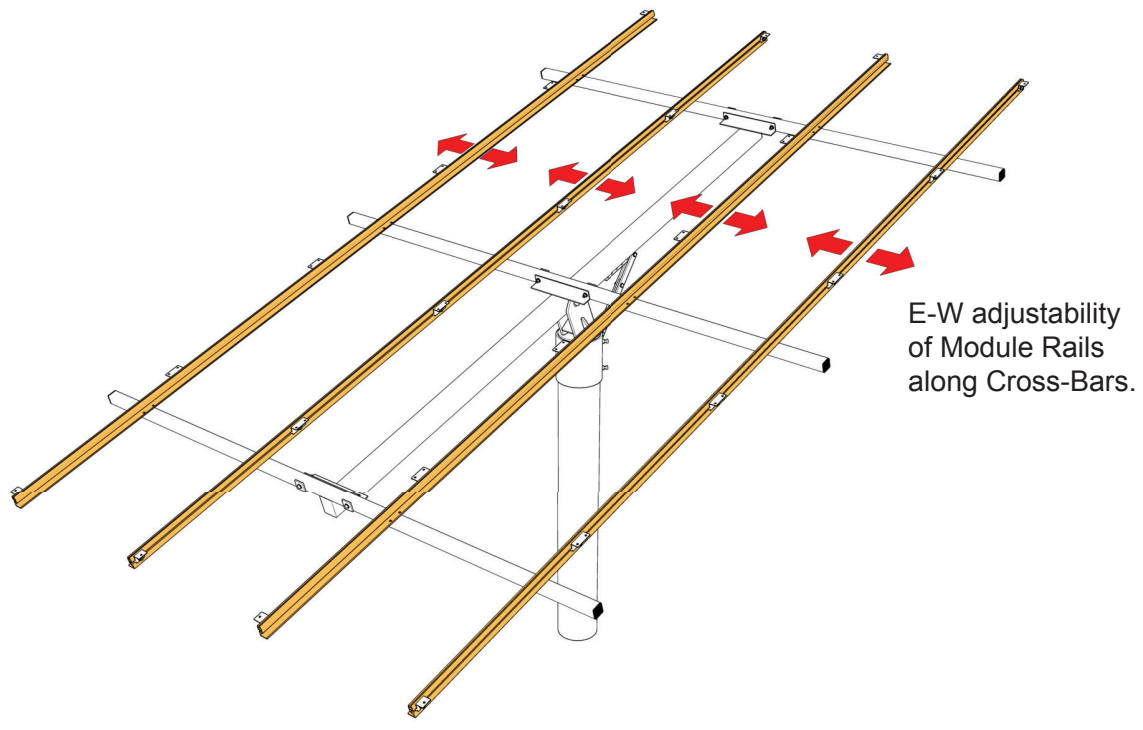

UTPM10 Type G Parts Identification

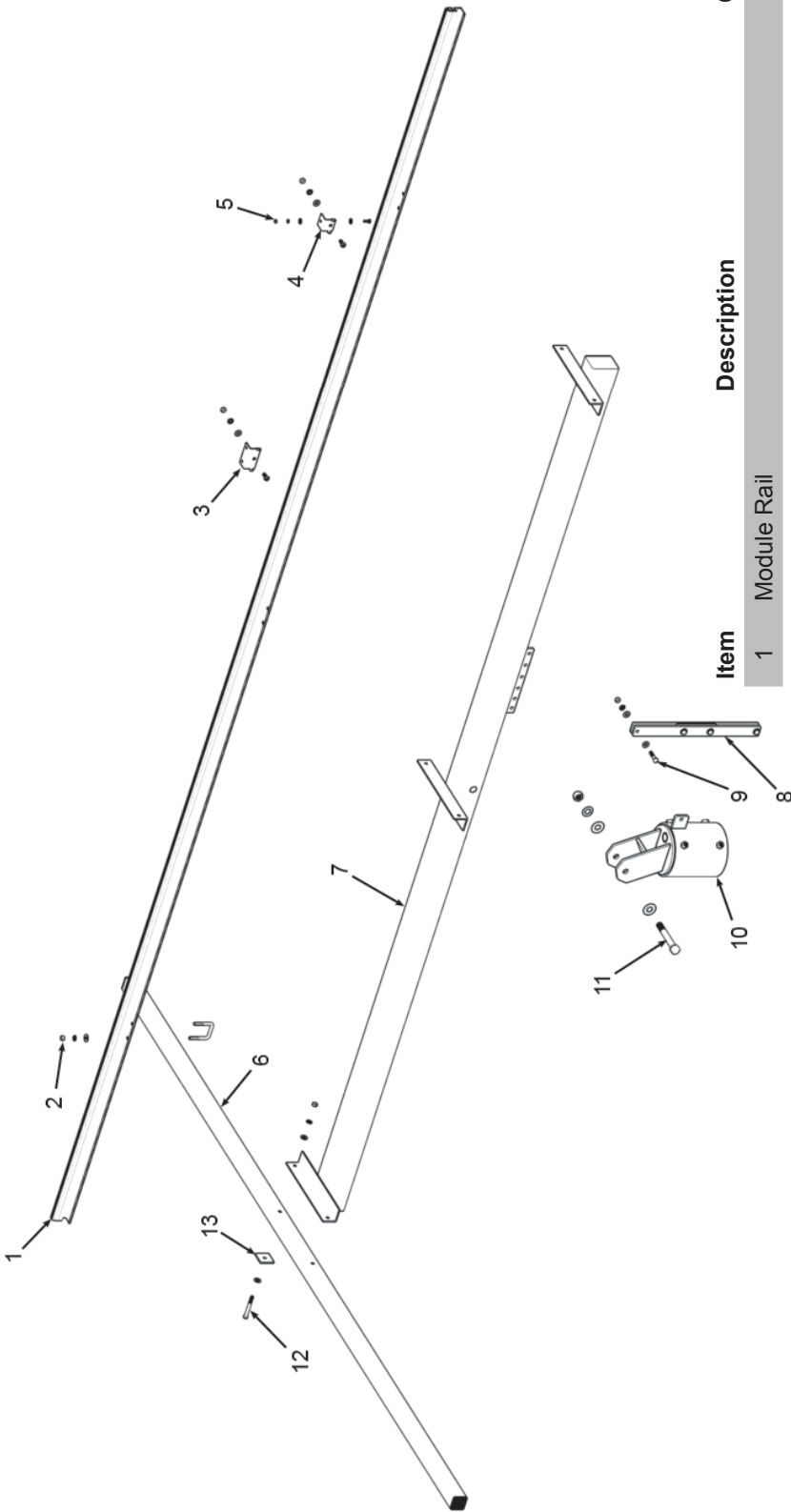

Item	Description	Qty
1	Module Rail	4
2	3/8" x 2" x 2 5/8" U-Bolt, lock & flat washers, hex nut	12 sets
3	Double Hole Slide Plate, 3/8" x 7/8" Hex Bolt, lock & flat washer, hex nut	16 sets
4	Single Hole Slide Plate, 3/8" x 7/8" Hex Bolt, lock & flat washer, hex nut	8 sets
5	1/4" x 3/4" Bolt, lock & flat washers (2 flat washers), secures PV Module	40 sets
6	Cross-Bar	3
7	Strongback	1
8	Support Bar	1
9	1/2" x 1-3/4" Bolt, lock & flat washers (2 flat washers)	2 sets
10	Mounting Sleeve	1
11	1" x 6" Pivot Bolt, lock & flat washers (2 flat washers)	1 set
12	3/8" x 3 1/4" Bolt, lock & flat washers (2 flat washers)	6 sets
13	3/8" Square washer	6

1 Calculate Site Specific Dimensions

NOTE
 When selecting mounting holes, make certain that the hole diameters accept 1/4" hardware as it will be used to secure the PV Modules to the system.

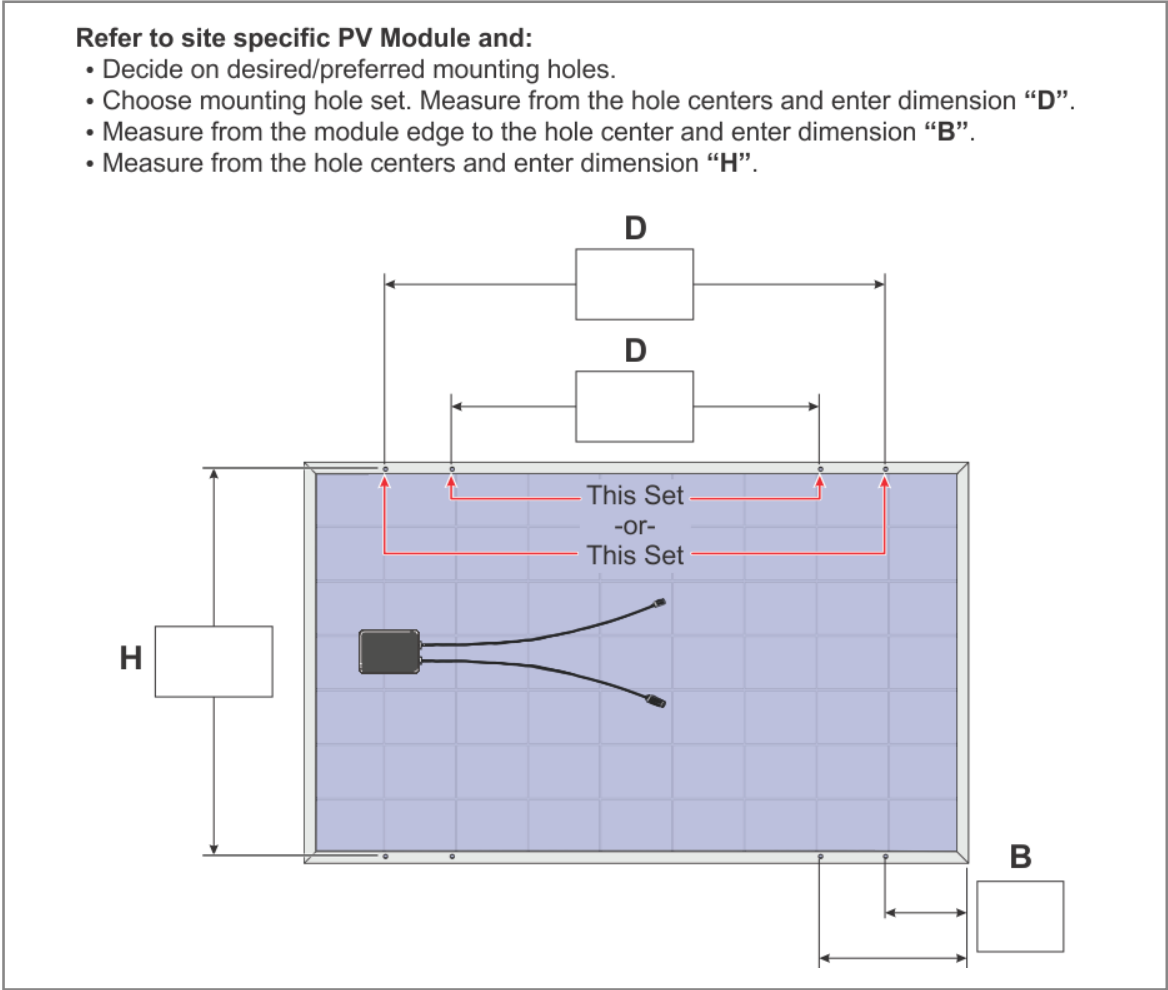

The dimensions must be taken from the site-specific Modules. The dimensions will be used to calculate the Module Rail positions.

2 Calculate and Mark the Rail Positions on Cross-Bars

Use the worksheet on the next page to calculate Rail positions on the Cross-Bars. Enter the two dimensions from above and complete the calculations. The resulting dimensions set the Inboard "I" and Outboard "O" Rail positions which will be measured and marked on the Cross-Bars.

2 Calculate and Mark the Rail Positions on Cross-Bars (continued)

Module Rail Positioning Calculator: Locate positions I & O

Factor	Description
A	.25" or one-half of the .50" gap between Modules.
B	Module mounting hole dimension "B" from previous page.
C	1.0" distance from edge of Module Rail to center of Slide Plate mounting hole.
D	Module mounting hole dimension "D" from previous page.
I	Distance from center of Cross-Bar to edge of Module Rail.
O	Distance from edge to edge of Module Rails.

Calculate Position I

$$\boxed{.25"} + \boxed{} + \boxed{1.0"} = \boxed{}$$

A B C Position I

Calculate Position O

$$\boxed{} - \boxed{2.0"} = \boxed{}$$

D C x 2 Position O

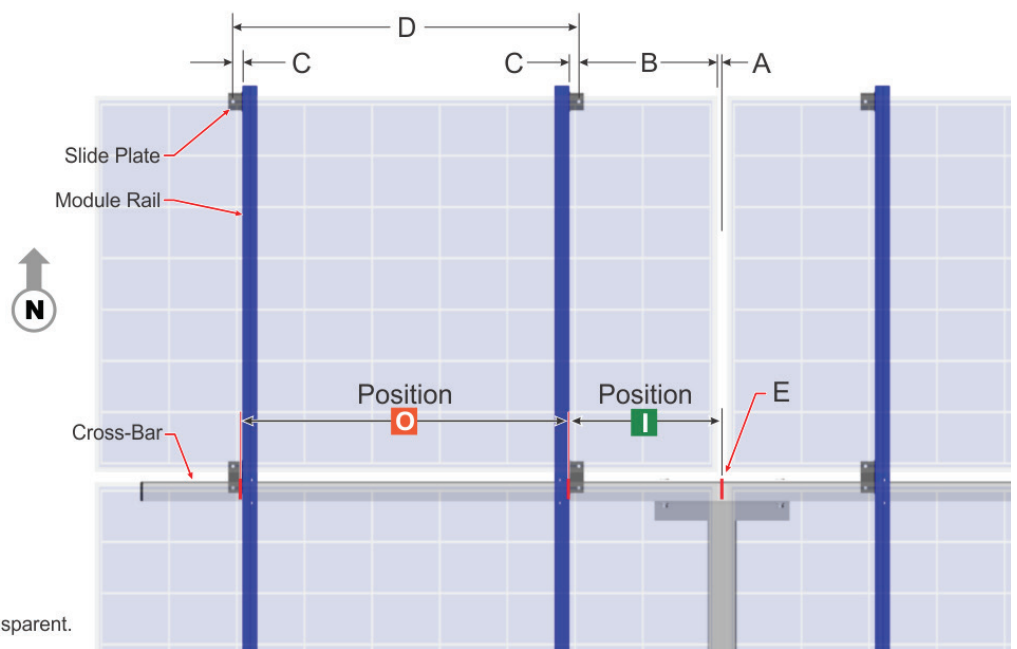
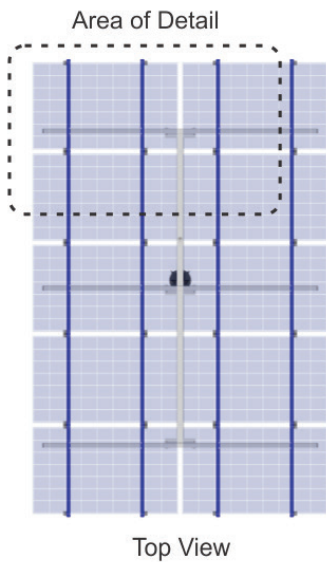

Note: For clarity, PV Modules are shown transparent.

3 Mark the Cross-Bars

NOTE
 Use precision when measuring and marking the Rail positions on the Cross-Bars.

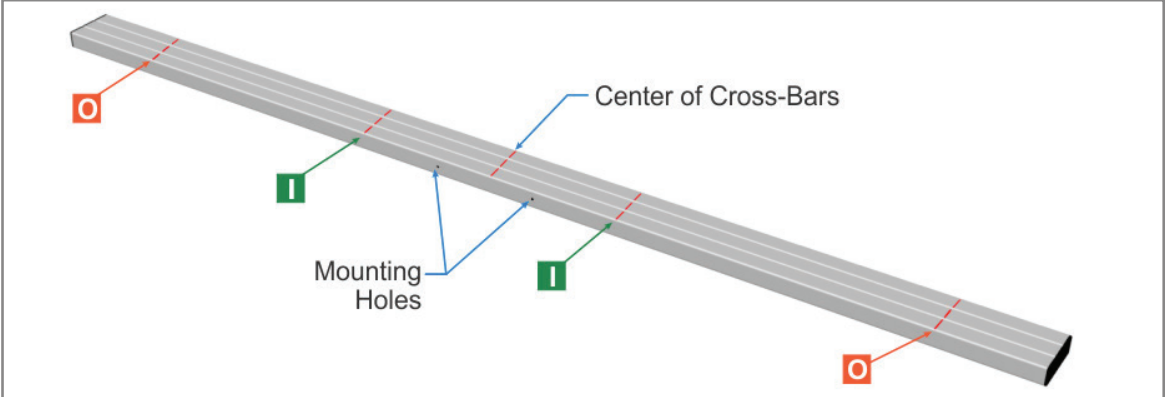

Measure and mark the center of the Cross-Bars then use the calculated dimensions I and O from the previous page to mark off their respective Rail positions on the Cross-Bars. The image below shows these marks and their relationship to the Cross-Bars and Rails after assembly.

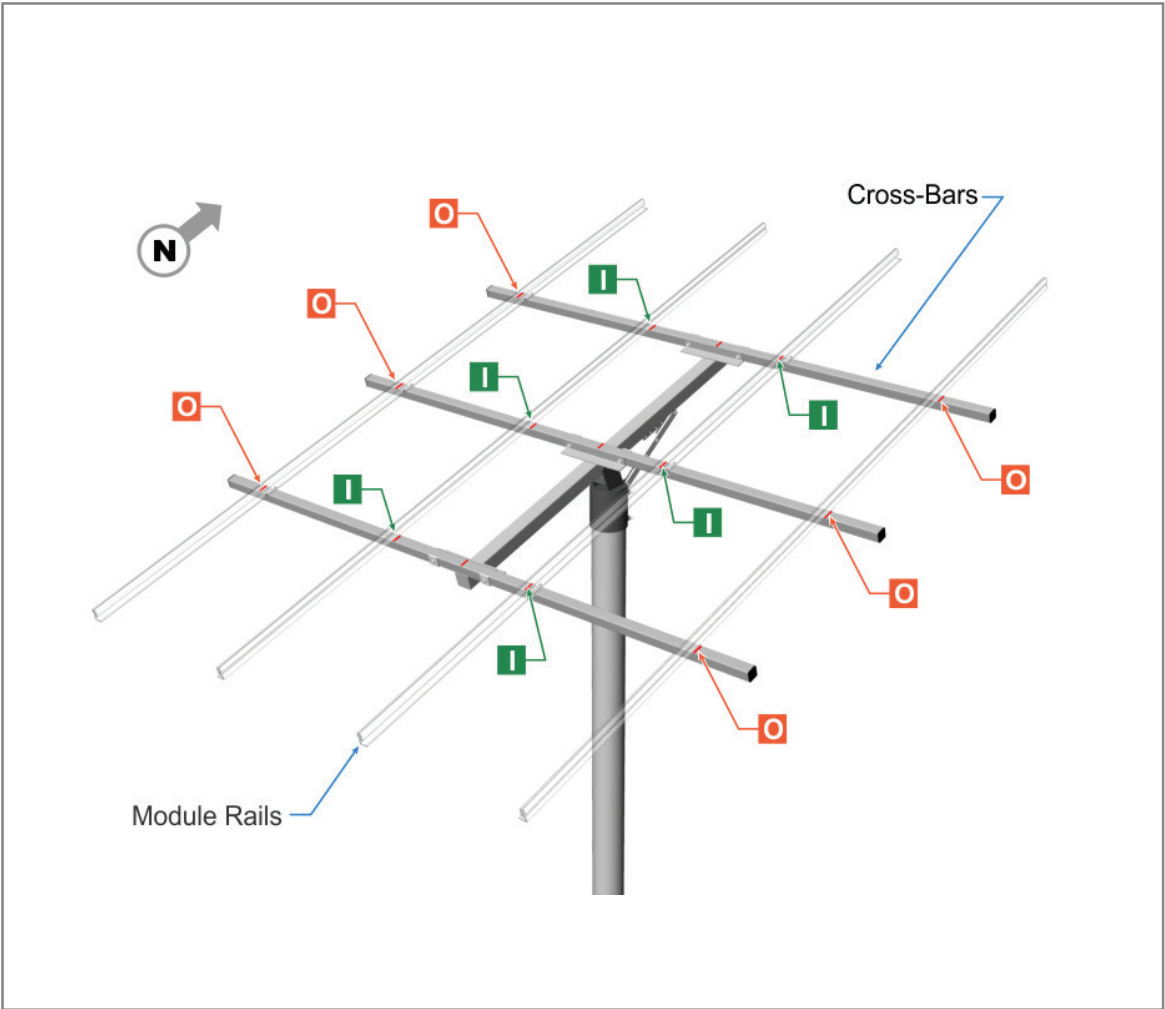

4 Calculate and Mark Slide Plate Positions on Module Rails

Use this worksheet to calculate the eight Double Hole Slide Plate positions on the Rails. Enter dimensions "H" from Step 1 and complete the calculations. The results define positions "K" to be measured and marked on the four Rails for the eight Double Hole Slide Plates.

Factor Description

- H** N-S distance between PV Module mounting holes.
- J** 1.125" distance from Module mounting hole to Rail mounting hole of Double Hole Slide Plate.
- K** Distance (C to C) from Double Hole Slide Plate to Double Hole Slide Plate. Mark these positions on Module Rails.

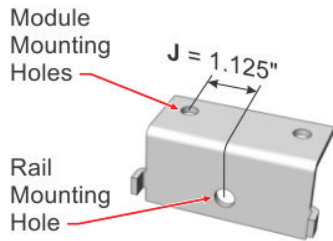

"J" Factor of Double Hole Slide Plate

Calculate Position K

x .50 + 1.125" =
H **J** **Position K**

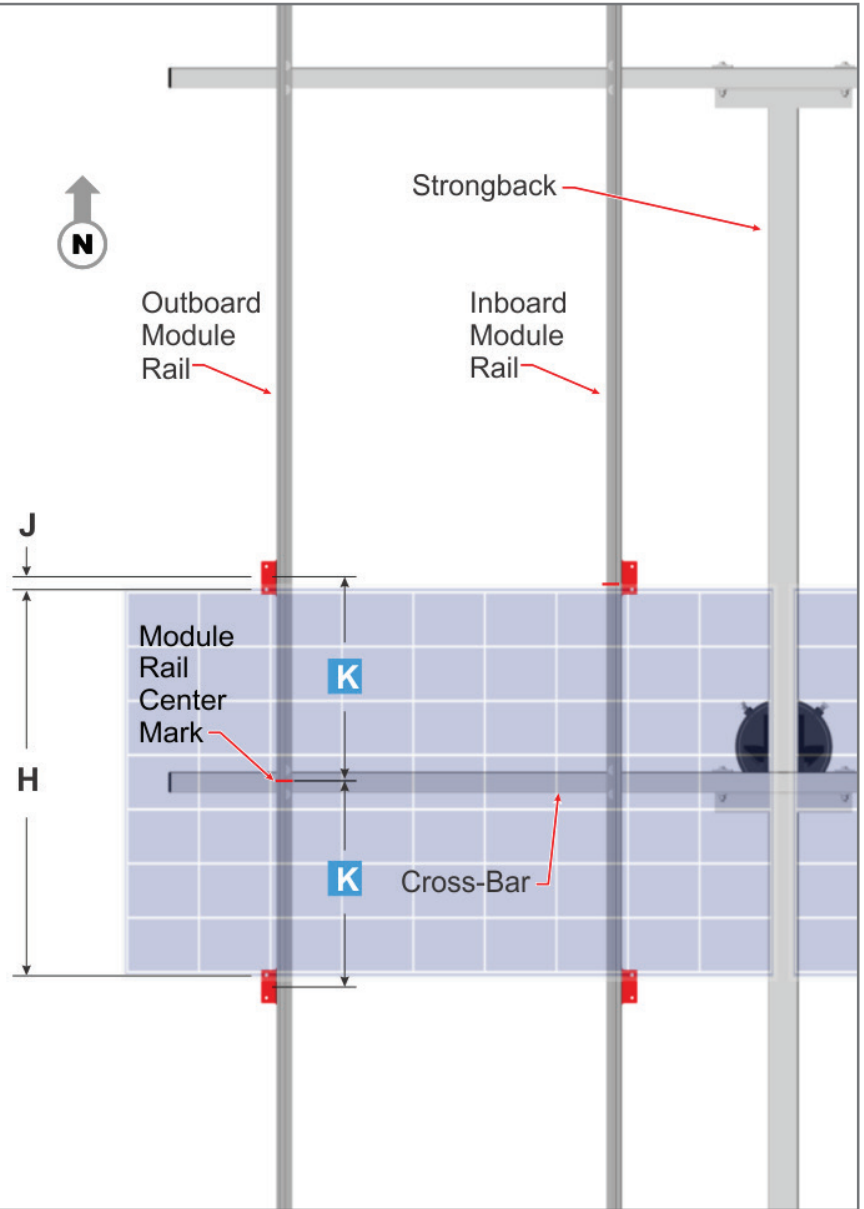

4 Calculate and Mark Slide Plate Positions on Module Rails (continued)

NOTE
Use precision when measuring and marking the Double Hole Slide Plate positions on the Module Rails.

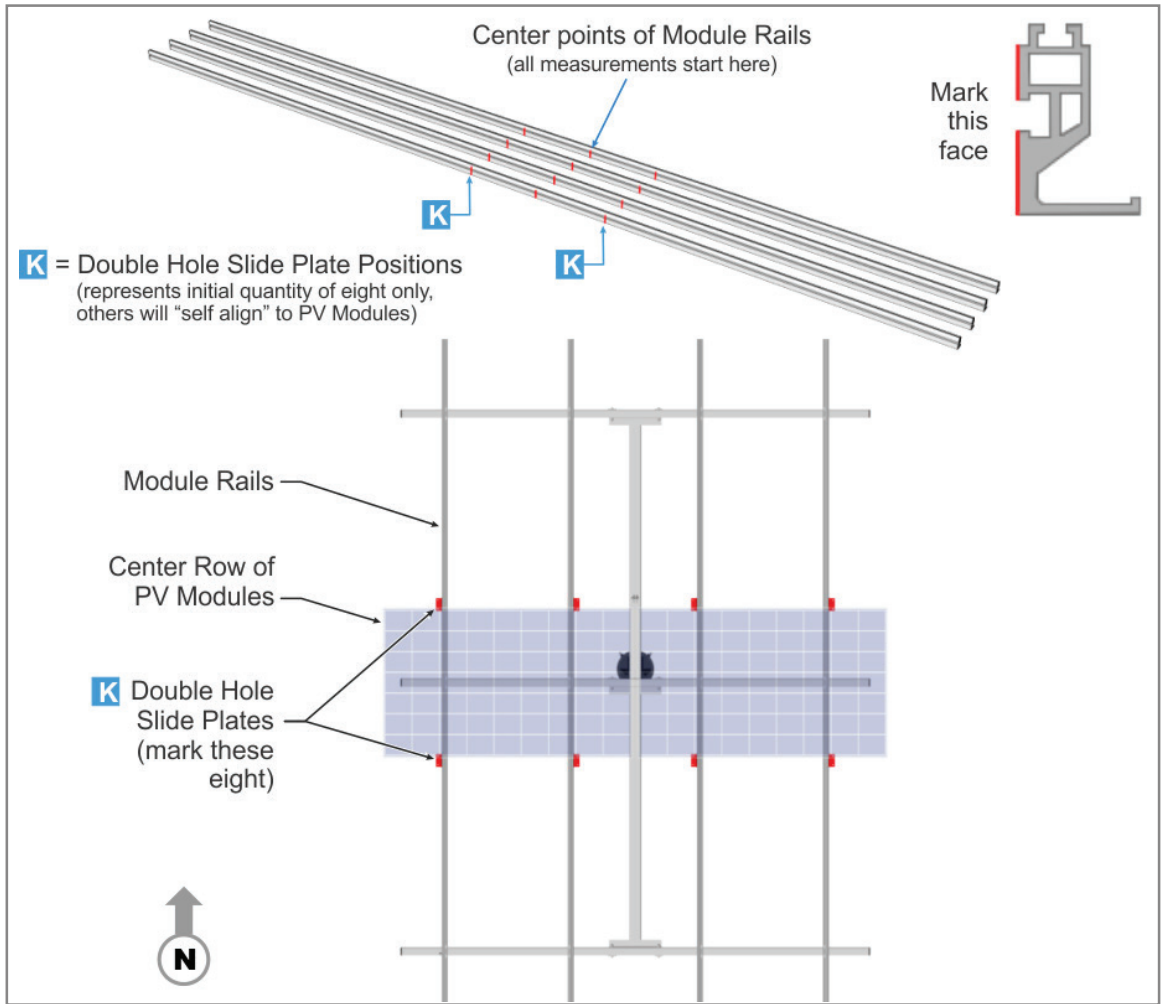

Locate the center of the Rails and mark as shown above. These marks correspond to the "K" dimension representing the locations for the eight Double Slide Plates (two-per Rail). The remaining Slide Plates do not require marks as they will be aligned to the Module mounting holes as the Modules are installed.

5 Pre-assemble the Slide Plates

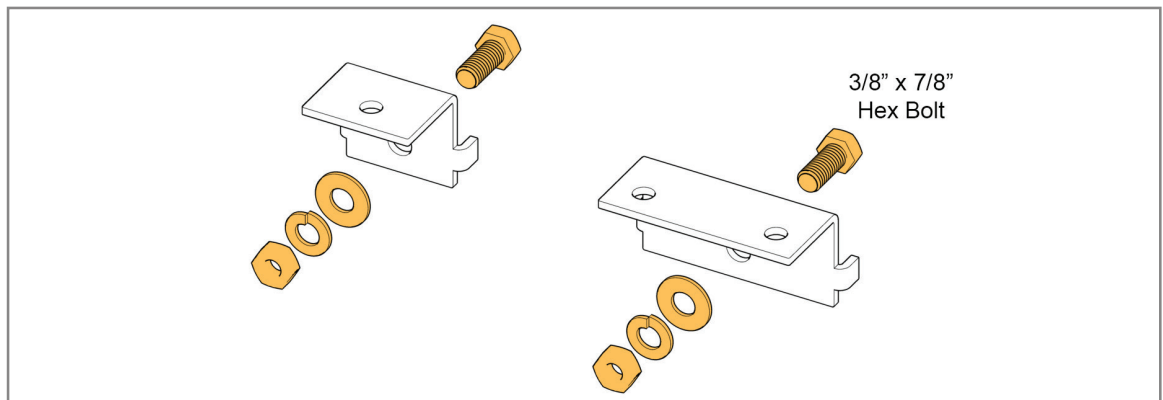

Pre-assemble each of the Slide Plates using 3/8" x 7/8" Hex Bolt, Flat Washer, Lock Washer, and Hex Nut. Leave the hardware loose for next step.

6 Attach Double Hole Slide Plates to Rails

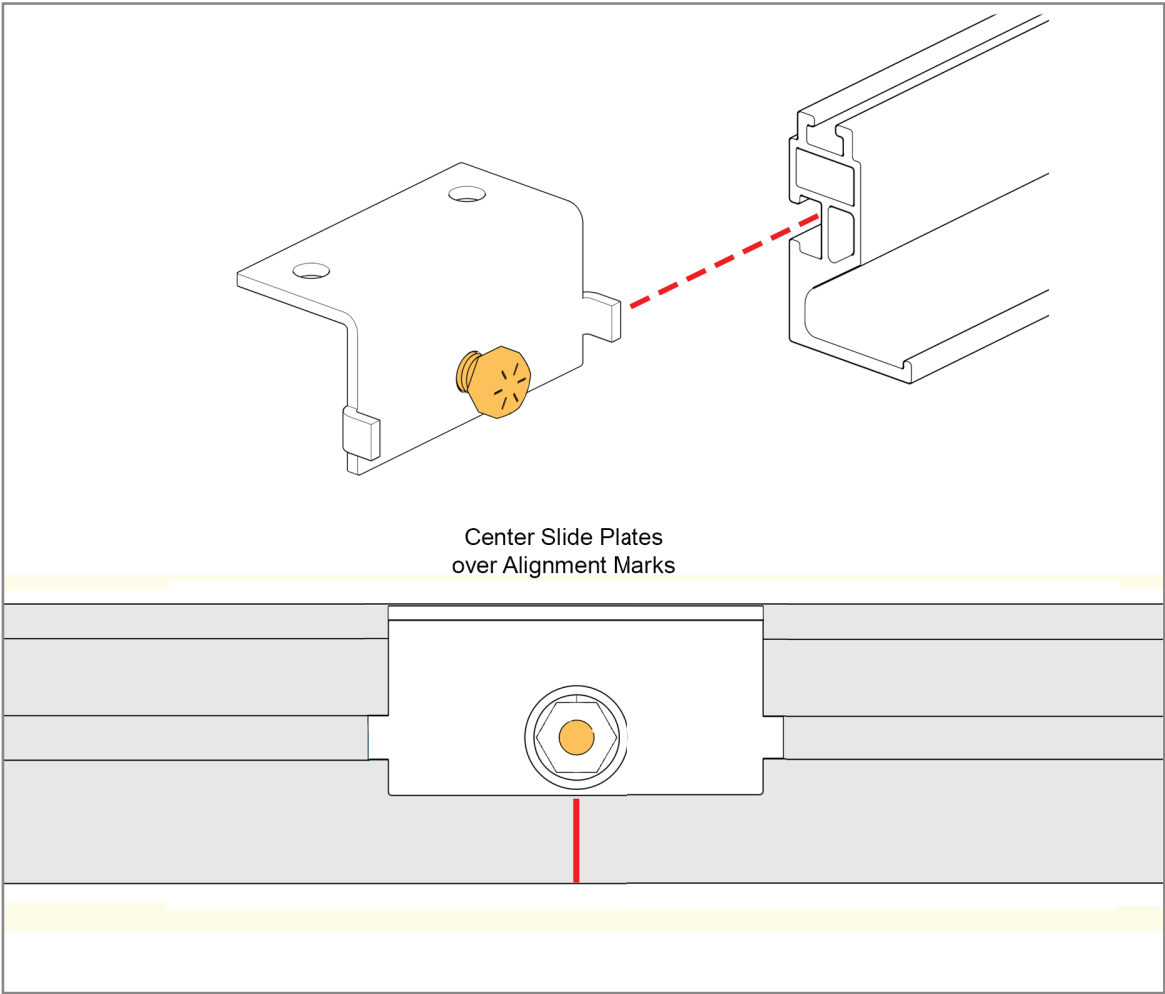

On each of the four Rails, install the two Double Hole Slide Plates to be centered over the previously made marks on the Rails. Insert the head of the Hex Bolt into the Rail channel as shown and align their centers over the marks. Tighten these eight Slide Plates securely and **torque at 32-34 ft.-lbs.**

7 Attach Remaining Double Hole Slide Plates and the Single Hole Slide Plates to Rails

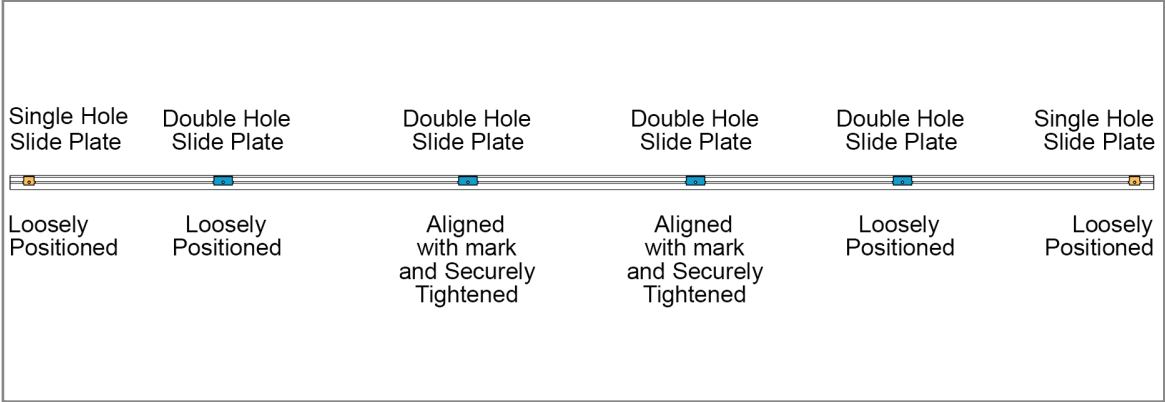

Install the remaining two Double Hole Slide Plates and the two Single Hole Slide Plates in a similar manner, loosely positioning them as shown above. These do not align to any marks or measurements. They will be moved into alignment with the Module mounting holes as the Modules are installed. Hand tighten for now.

8 Install the Mounting Sleeve on Vertical Pipe

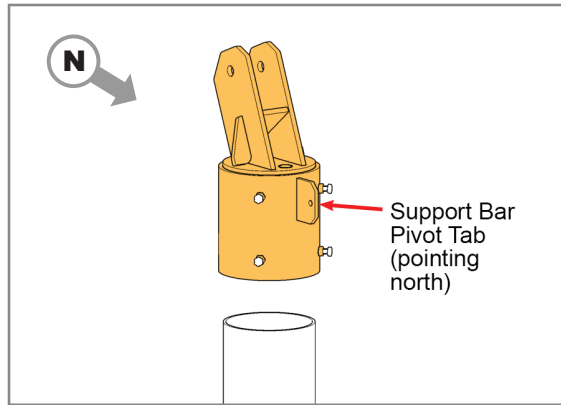

Slip the Mounting Sleeve on top of the Mounting Pole allowing it to slide down and bottom out on the Pole. Rotate the Mounting Sleeve so that the Support Bar

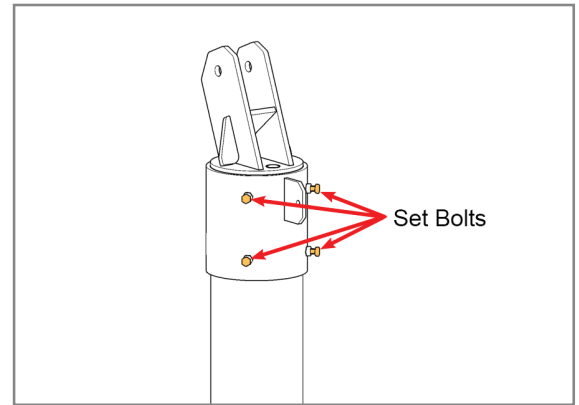

Pivot Tab is pointing north and the Strongback Vertical Towers are leaning south. Tighten Set Bolts and **torque to 55-60 ft.-lbs.**

9 Install the Strongback

CAUTION

This is a two person activity. The Strongback must be held in place by one person while the second person aligns it and secures it to the Mounting Sleeve using the Pivot Bolt and the 1/2" hardware. Failure to do so could lead to serious personal injury.

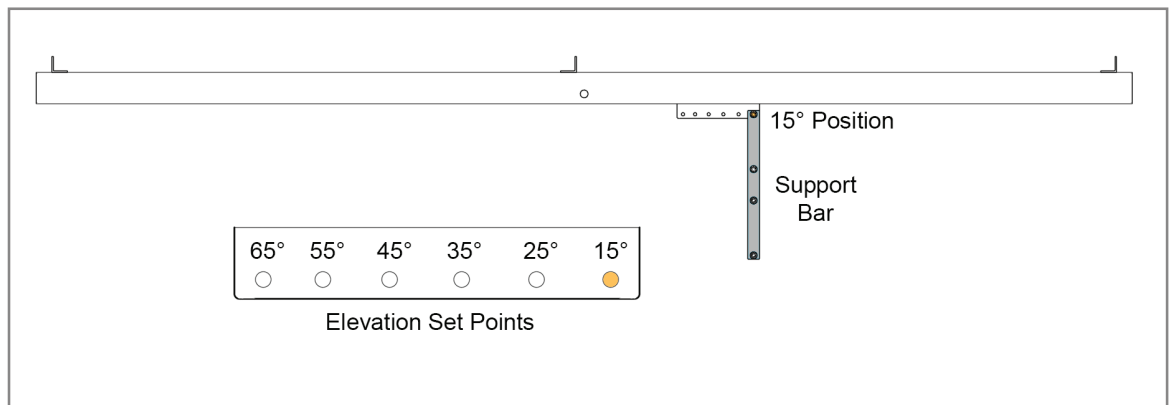

Although this system offers variable elevation set points, for ease of assembly, set the angle to 15°. Optimum tilt setting of the rack will take place later in these instructions.

CAUTION

The Pivot Bolt cannot be left loose - the Mounting Sleeve Vertical Towers must be firmly clamped to the sides of the Strongback eliminating any gaps between the Vertical Towers and the Strongback. See the illustration on following page.

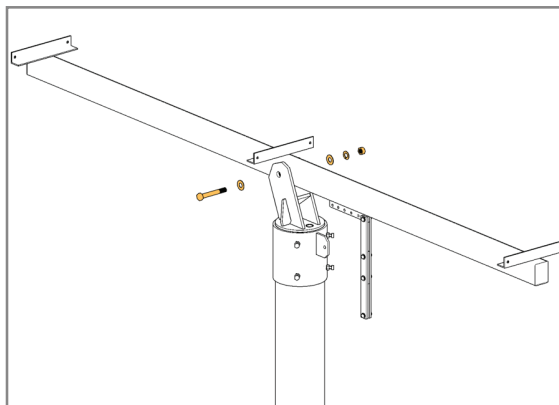

Secure Strongback to Mounting Sleeve with Pivot Bolt, two Flat Washers, Lock Washer and Nut. Secure Support Bar to Mounting Sleeve with 1/2" x 1-3/4" Bolt, two Flat Washers, Lock Washer and Nut.

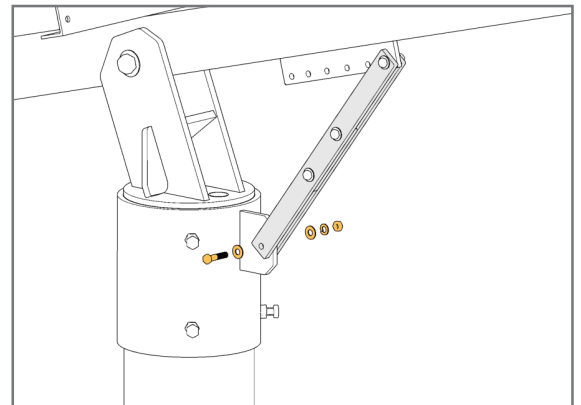

Torque Support Bar hardware at 72-80 ft.-lbs.

9 Install the Strongback (continued)

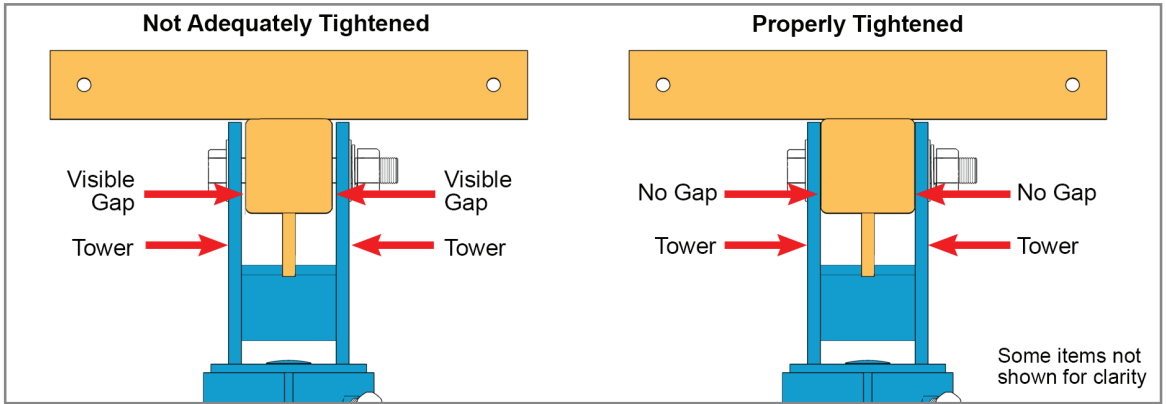

Tighten Pivot Bolt closing any visible gaps between the Strongback and the Mounting Sleeve Towers. **Torque to 330-350 ft.-lbs.**

10 Install the Cross-Bars

CAUTION

This is a two person activity. Cross-Bars are long and unstable before they are fully secured to the Strongback. Cross-Bars must be held in place by one person while the second person aligns and secures them to the Strongback. Failure to do so could lead to serious personal injury.

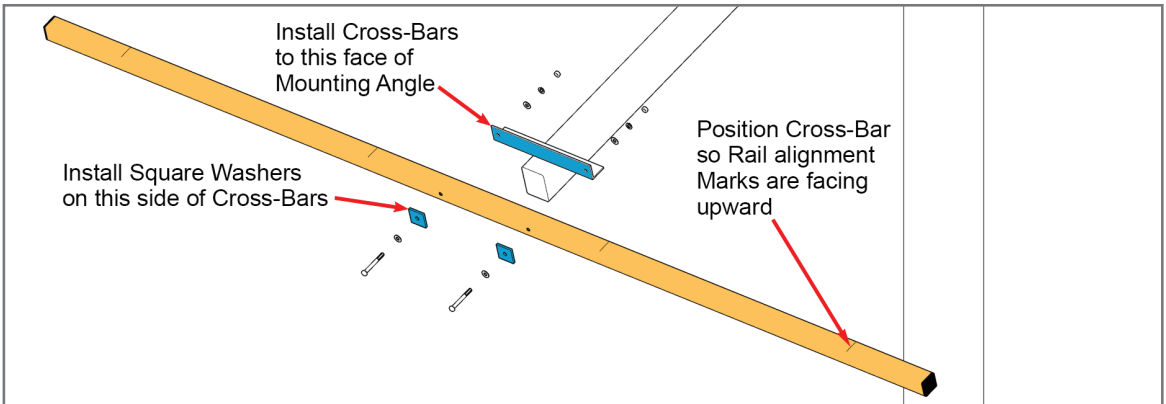

Install the three Cross-Bars with 3/8" x 3-1/4" Hex Bolt, Square Washer, Flat Washers, Lock Washer and Hex Nut. Tighten and **torque to 30-32 ft.-lbs.**

10 Install Rails

CAUTION

This is a two person activity. Module Rails are unstable before they are secured to the Rail Brackets.



When installing the Rails orient their profiles as shown.

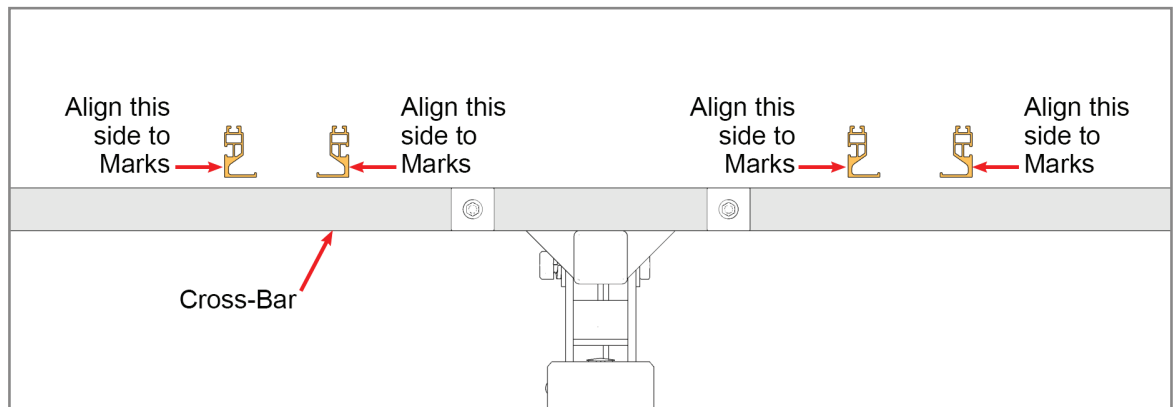

Be sure to align the correct side of the Rail with the Rail alignment marks on the Cross-Bars.

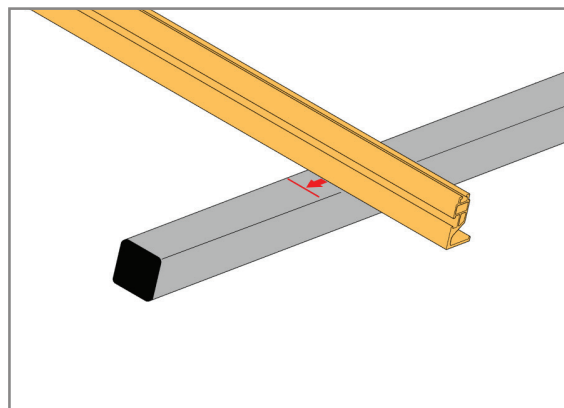

Align the Rail to the alignment marks and straddle its mounting holes over the Cross-Bar. Secure with 3/8" x 2" x 2-5/8" U-Bolt, Flat Washers, Lock Washers and

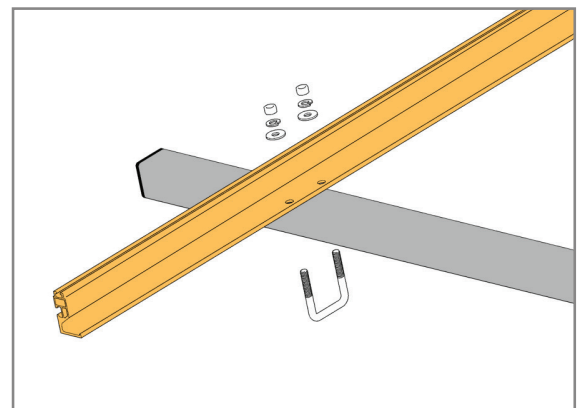

Hex Nuts at each Cross-Bar. Finger tighten for now to hold in place. Final tightening will come later.

12 Install Modules

CAUTION

This is a two person activity. Modules are heavy and unstable before they are fully secured to the Module Rails. PV Modules must be held in place by one person while the second person aligns and secures them to the Module Rails. Failure to do so could lead to serious personal injury and damaged components.

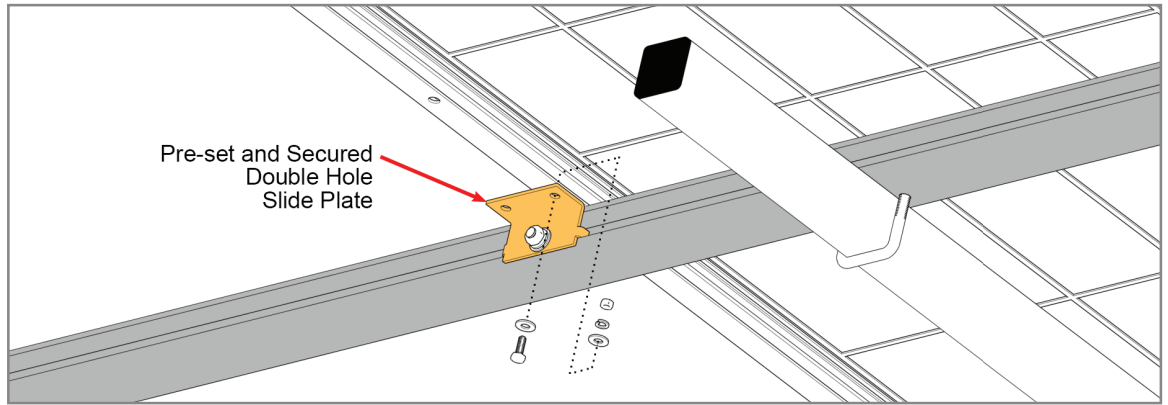

Align Module mounting holes with the installed Double Hole Slide Plates and secure Module with 1/4" x 3/4" Hex Bolt, Flat Washers, Lock Washer and Hex Nut. Finger tighten for now. Repeat on opposite Rail.

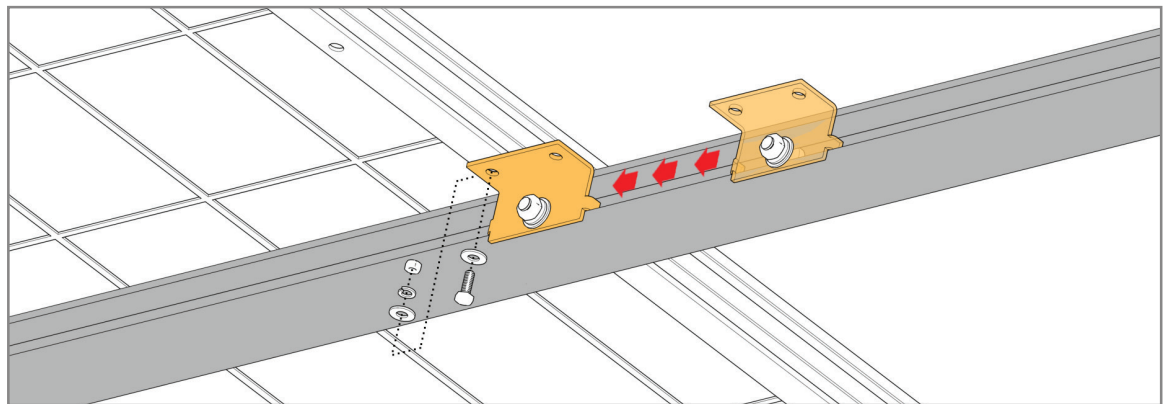

Slide the next Double Hole Slide Plate into alignment with the Module mounting hole. Secure Module with 1/4" x 3/4" Hex Bolt, Flat Washers, Lock Washer and Hex Nut. Finger tighten for now. Repeat on opposite Rail.

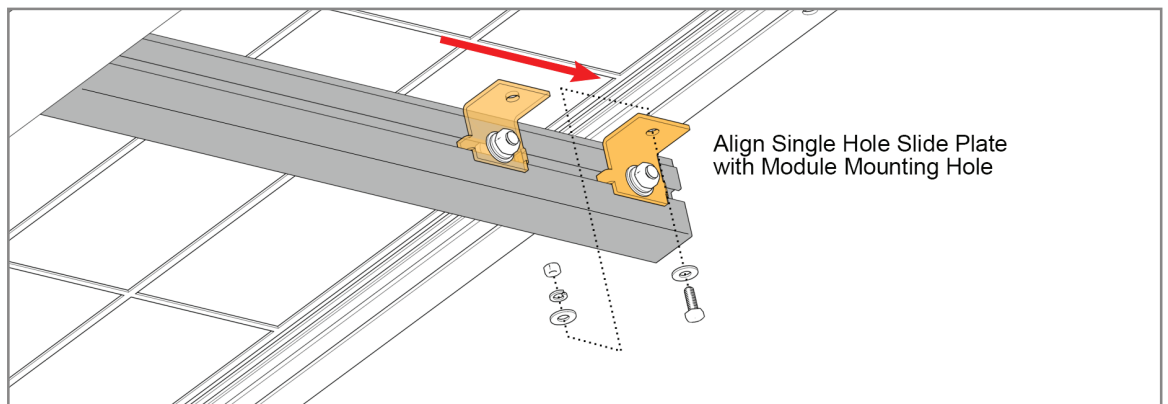

Slide the Single Hole Slide Plates into alignment with Module mounting hole. Secure Module with 1/4" x 3/4" Hex Bolt, Flat Washers, Lock Washer and Hex Nut. Finger tighten for now. Repeat on opposite Rail. Continue in this manner and install the remaining Modules.

13 Square and Align the Array. Return and Tighten Mounting Hardware

CAUTION

Be certain to re-tighten all Module Rail and PV Module mounting hardware and torque to the specified values. Failure to do so could lead to structural failure, damaged components and/or serious personal injury.

Using a square and visual references, ensure that the array is aligned to the mounting structure. Confirm that the PV Modules are square and have consistent even spaces all around. Adjust if necessary.

Tighten Mounting Hardware

- A. Return and tighten each set of the 3/8" U-bolts, securing the Module Rails to the Cross-Bars. **Torque all at 32-34 ft.-lbs.**
- B. Return and tighten each of the 3/8" hardware securing all of the Slide Clamps (Single and Double Hole) to the Module Rails. **Torque all at 32-34 ft.-lbs.**
- C. Return and tighten each set of 1/4" mounting hardware, securing the PV Modules to the Slide Clamps. **Torque all at 6-8 ft.-lbs.**

14 Adjust the Array Tilt Angle

WARNING

Do not attempt to remove the Pivot Bolt during tilt adjustments! Removal could lead to serious personal injury or death. Adjustments are made with the Pivot Bolt hardware loosened but in place.

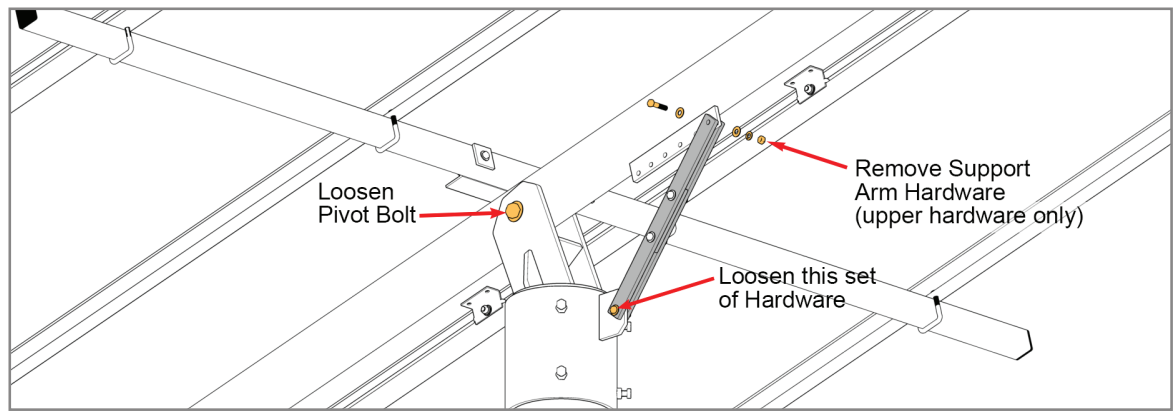

CAUTION

This is a two person activity. As the hardware is loosened, the rack is heavy and unstable. The rack must be held in place by one person while the second person loosens the hardware and then re-installs and tightens the hardware back in place. Failure to do so could lead to serious personal injury and damaged components.

- A. While one person holds the south edge of rack, the other loosens the Pivot Bolt and the hardware securing the lower end of the Support Arm hardware.

Now remove the upper 3/8" hardware attaching the Support Bar to the Strongback.

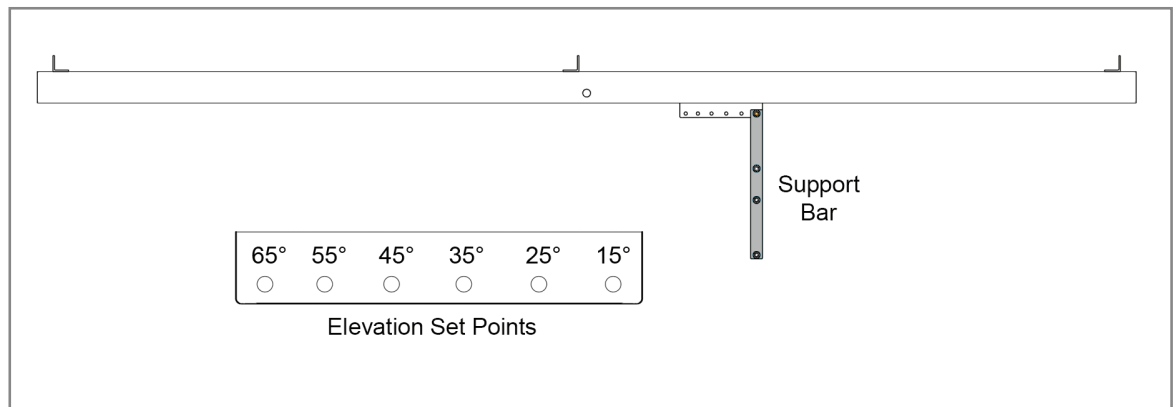

- B. Tilt the rack to the desired elevation angle (15°, 25°, 35°, 45°, 55° or 65°) and reinstall the 3/8" hardware securing the Support Bar to the Strong-

back. Tighten hardware (at both ends of Support Bar) and **Torque to 72-80 ft.-lbs.**

15 Adjust the Array Tilt Angle (continued)

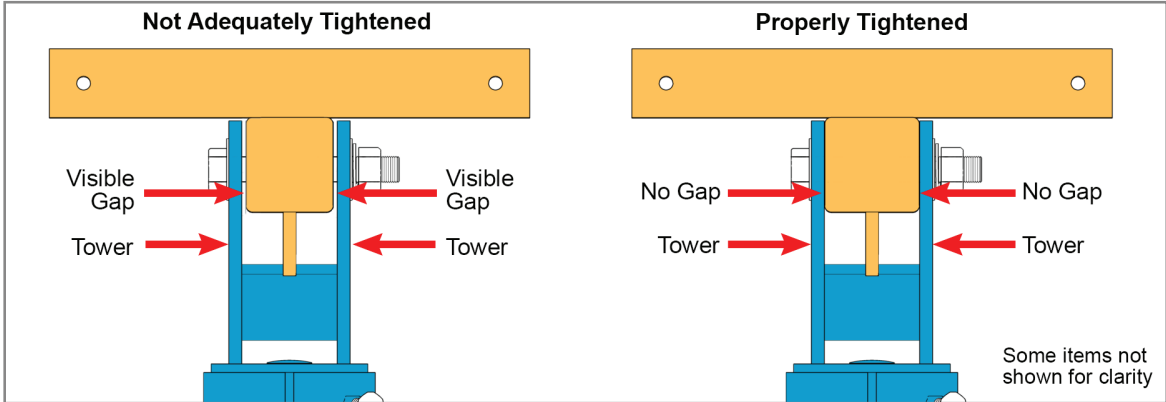

C. Re-tighten the Pivot Bolt. The Pivot Bolt cannot be left loose - the Mounting Sleeve Vertical Towers must be firmly clamped to the sides of the Strongback eliminating any gaps between the Vertical

Towers and the Strongback. **Torque to 330-350 ft.-lbs.**



PREFORMED LINE PRODUCTS

Global Headquarters
660 Beta Drive
Mayfield Village, OH 44143

Telephone: 800.260.3792
Fax: 440.442.8816
preformed.com
Email: info@plpsolar.com