

# QBox™

Installation Manual

Elevated Water Seal Technology™

Patented Junction Box  
For Composition/Asphalt Shingle Roofs



**Quick Mount PV®**  
RESPECT THE ROOF

U.S. Patent No.  
9,496,697  
9,742,173

# Table of Contents

## Installation Instructions

I.	Important Safety Instructions.....	1
I.I	Save These Instructions.....	1
I.II	Safety Callouts.....	1
I.III	Safety Warnings and Cautions.....	2
II.	Product Description.....	4
II.I	Overview.....	4
I.II	Dimensions.....	4
I.III	QBox Contents.....	5
III.	Installation Overview.....	6
II.I	QBox Location.....	6
IV.	Installation.....	7
IV.	Wiring.....	9
VI.	Wiring Diagrams and Proper Use.....	11
VII.	System Specifications and Ratings.....	13

# I. IMPORTANT SAFETY INSTRUCTIONS

Read all instructions and warning labels provided with the product prior to installation.

This product has been designed and tested to national safety requirements to ensure your personal safety. Improper use may result in potential electric shock. To reduce the risk of personal injury, read and follow all instructions and warnings in this installation manual.

## I.I SAVE THESE INSTRUCTIONS

This manual contains important instructions that shall be followed during installation and maintenance of the system. This manual should be stored near the product's installation and must be available at all times. This product is intended for operation in an environment having a maximum temperature of 75°C.

## I.II Safety Callouts

There are important safety information and instructions in specially formatted callouts throughout this document.

The callouts along with their general use instructions are shown below.

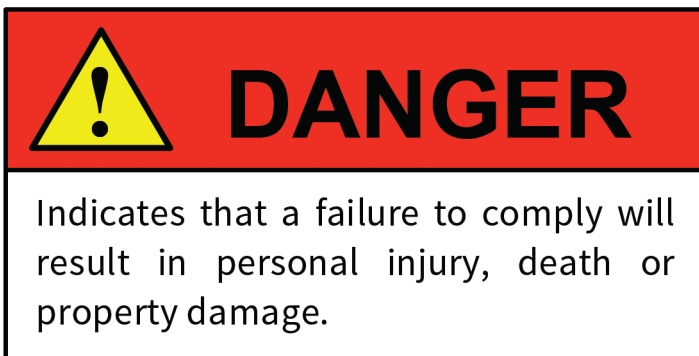

 **DANGER**

Indicates that a failure to comply will result in personal injury, death or property damage.

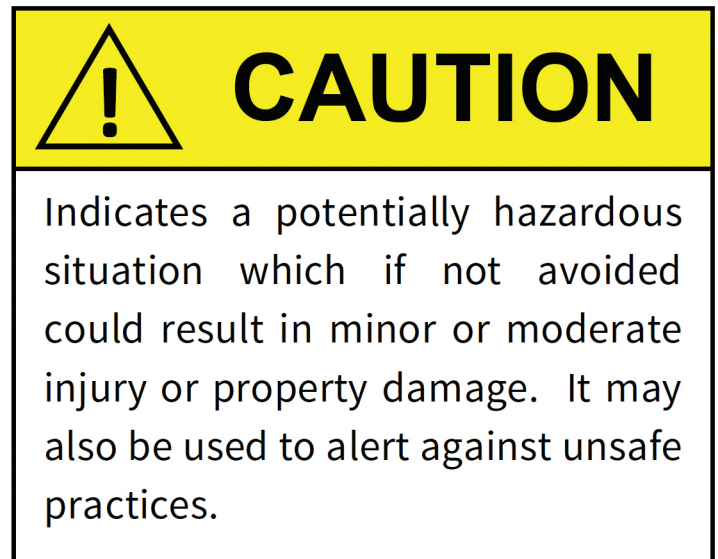

 **CAUTION**

Indicates a potentially hazardous situation which if not avoided could result in minor or moderate injury or property damage. It may also be used to alert against unsafe practices.

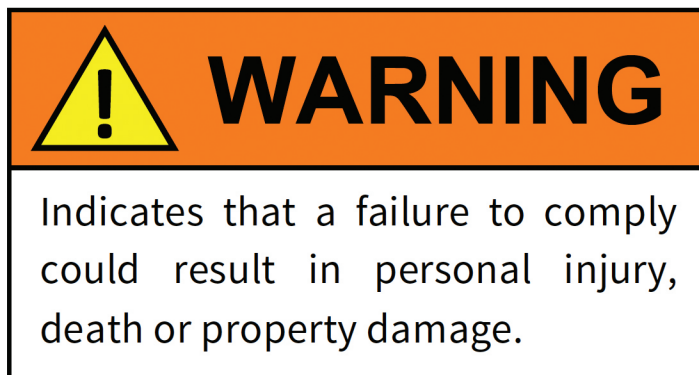

 **WARNING**

Indicates that a failure to comply could result in personal injury, death or property damage.

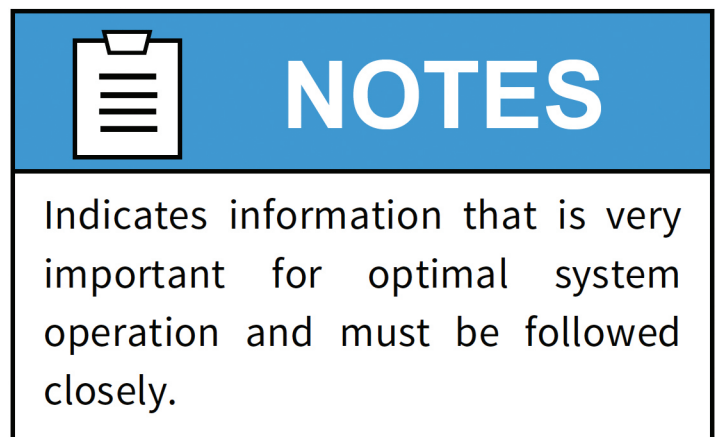

 **NOTES**

Indicates information that is very important for optimal system operation and must be followed closely.

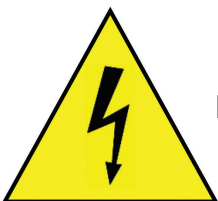

Electrical Voltage May Be Present

## I.III Safety Warnings and Cautions

This product is only to be installed by qualified personnel. These installation and service instructions are for qualified personnel only. To reduce the risk of electric shock, injury or death, all wiring and connection must be performed by qualified personnel. Do not perform any installation or service other than that to which you are qualified to perform.



Lethal voltages are present during the installation, operation and service of this equipment. Proper precautions must be taken at all times to ensure the safety of the service personnel.

At all times follow state and federal occupational safety and health administration (OSHA) guidelines and regulations. Ensure the electrical installation is in accordance with the National Electrical Code (NEC), ANSI, NFPA 70, all local electrical codes, and with the authority having jurisdiction. If there are any contradictions between the NEC and this document, follow the NEC requirements.



### WARNINGS

- Ensure all electrical conductors are at zero voltage potential before installing or servicing this unit.
- Never break contact on a circuit without using the appropriate disconnect device.
- Follow established lockout-tagout procedures for all electrical conductors prior to servicing.
- Photovoltaic systems produce potentially lethal electrical energy when exposed to light. Use all appropriate procedures to de-energize the photovoltaic system and the conductors leaving the system prior to service.
- Ensure all wires are in good service condition. Nicked, pinched, or damaged wires can lead to electrocution or cause a fire.
- Do not use wire connection devices other than those supplied with this equipment. Using other non-certified connection devices could create a shock or fire hazard.
- Use all appropriate electrical safety equipment as defined by OSHA or by the local or national governing safety body for servicing and installing high voltage products.
- Wear safety equipment rated for a minimum of 600V or as required for the specific site conditions.
- Disconnect all conductors from the array prior to making or breaking connections within this product or within any other point of the circuit.
- Activating the AC and/or DC disconnect switch within a circuit does not shut off potential electrical energy or voltage from the photovoltaic panels. Ensure the photovoltaic array is disconnected and there is zero voltage potential on the conductors being installed before servicing this product.
- Do not use this equipment in a manner other than that outlined in these instructions. Doing so may cause personal injury or death.
- Check all wiring and connections for integrity and proper installation prior to energizing the circuit.
- Always de-energize the DC and AC circuits prior to installation or service. Neglecting to do so could result in property damage, personal injury or death.

- If any part of this product becomes damaged, remove and discard the entire unit, and replace with a new one. Failure to do so could result in fire, property damage, personal injury, electrocution, or death.
- When disconnecting the inverter, allow 15 minutes for all electrical storage components to discharge before servicing any conductors in that circuit.
- Do not install this equipment in wet conditions. This could result in electrocution, personal injury, or death.
- Be aware of and work away from power lines. Contact with power lines could result in electrocution, personal injury, or death.
- Do not install if the roof is wet, frosted, or covered by ice or snow.
- Whenever drilling into an attic space, ensure that no electrical wires, conduit or electrical components are on the other side. Failure to note electrical equipment locations could lead to damage which could result in electrocution, personal injury or death.
- When determining ambient operating temperature, system designer must take into account external sources of heat such as irradiance from the sun or the environmental conditions under which the product is installed such as under a PV module. Exceeding the temperature rating could cause electrical failure or arcing that could result in property damage, fire, electrocution, personal injury or death.



## CAUTIONS

- Do not exceed the maximum wire sizes specified in this manual.
- Use only wire combinations specified in this manual.
- Use proper safety and personal protective equipment (PPE) such as goggles and safety glasses, gloves, ear protection, hard hats, safety harness and fall protection, etc. Ensure you have proper training on how to use and install this equipment. Follow all national and local regulations and best practices.
- The installation of this product involves working around high-voltage electrical equipment. Follow applicable safety regulation and best practices to avoid creating an electrocution hazard.
- The installation of this product requires working on roofs. Follow applicable safety regulations and best practices to avoid falling from the work area. Take steps to prevent objects from falling off the roof. Cordon off the area on the ground directly under where the roof work will take place or equipment/tools will be stored.
- Do not use this equipment in a manner other than that outlined in these instructions. Doing so may cause damage to the equipment, or personal injury.
- Never work alone. Someone should always be in range of your voice or close enough to come to your aid in the event of an accident.
- Remove all rings, bracelets, necklaces, watches or other metal equipment that could become energized while working with electrical conductors and equipment.
- The maximum operating temperature of this equipment is 75°C. NOTE: this includes temperature rise over ambient due to irradiance from the sun. Qualified system designer and Engineer is responsible for identifying maximum temperature based upon site conditions.

# II. Product Description

## II.I Overview

The QBox Junction Box sits on top of a durable anodized aluminum flashing which utilizes Quick Mount PV's patented Elevated Water Seal Technology™ to waterproof the fasteners that connect the QBox to the roof. The QBox is designed to secure to the roof's sheathing without a pilot hole for fast installation and optimal roof placement. In addition, the QBox leverages the Elevated Water Seal Technology to create a waterproof pass-through for conduit from the QBox to the attic.

The QBox enclosure is made from highly durable and weather resistant polycarbonate. With excellent impact resistance and a wide operating temperature range, this product is suitable for all environments. In addition, since it is made of nonconductive material there is no need to ground the box or its door. A drill starter around the outside of the entire enclosure ensures the perfect hole location for your conduit attachment every time. All included components come unpackaged in the QBox to reduce installation time and packaging material management.

The QBox comes fully equipped with flashing, fasteners to install it to the deck, fittings for the through-the-deck conduit attachment, and waterproof wire nuts to either transition or combine two strings of conductors.

## II.II Dimensions

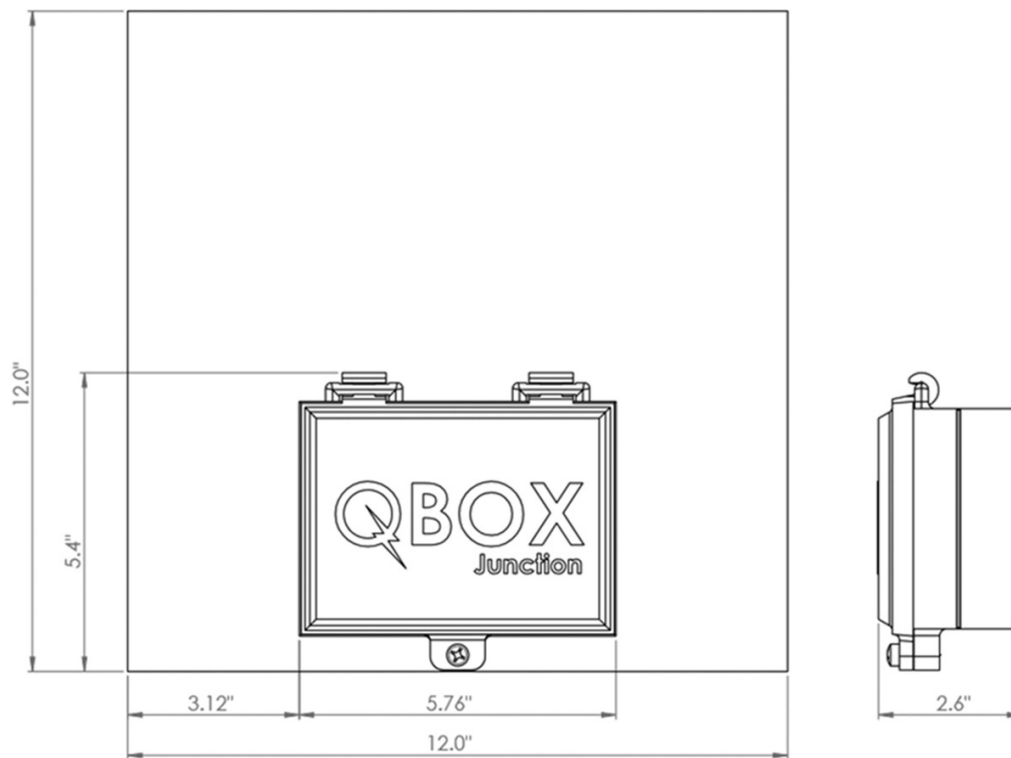

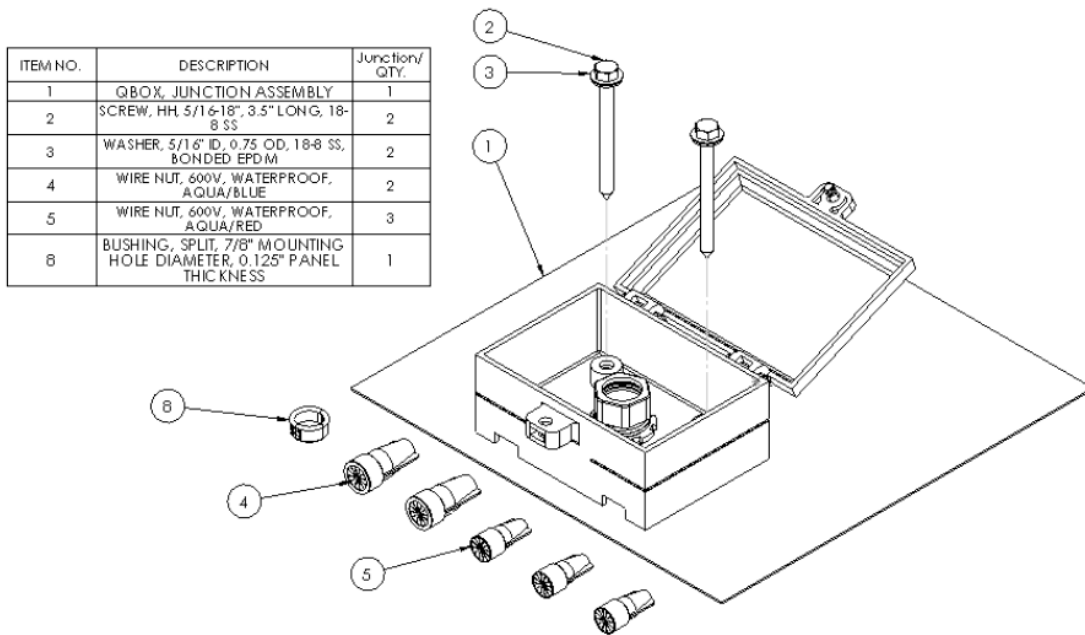

Not Included Due to Site Specific Needs:

- Strain relief fittings for PV homerun wires for sidewall pass-through.
- 3/4" EMT conduit for transition wiring for attic pass-through.
- Conduit connectors and fittings for transition wiring for sidewall pass-through.
- #8 or #10 AWG, min 90° C copper wire as required by NEC.

# III. Installation Overview

## III.I QBox Location

Locate the QBox during the system design process to ensure optimal placement and compliance to permit requirements. The QBox can be installed at any convenient location on the roof since it is designed for direct securement to the roof's sheathing. It is acceptable to install the QBox under a PV module as long as the maximum rated ambient temperature of the QBox will not be exceeded. To service the PV system, it is important to have access to the QBox after the installation. When installing the QBox under a module, consider placing it under the last module in a string or under a module that is easy to lift out of position for access.

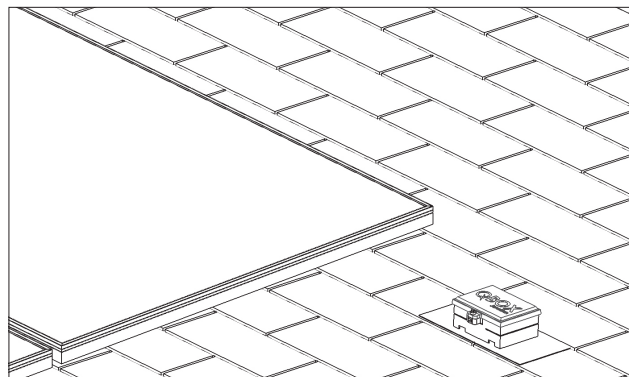
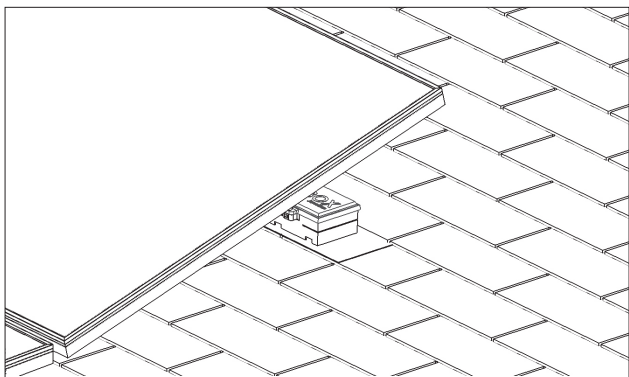

 **WARNING**

If modules are required to be removed or lifted during Q-Box servicing, ensure the system is designed such that the removal of the module will not disturb or break the system ground path. In addition, ensure the lifted module maintains its ground during servicing. Failure to follow these instructions could produce a shock hazard leading to personal injury or death.

The QBox utilizes a patented waterproof pass-through for 3/4" EMT to run system wires through the roof into the attic. If you run your wires through the attic, place the QBox in an optimal location for access when working inside the attic space. In addition, do not install the QBox directly over a rafter such that the rafter interferes with the conduit coming down from the QBox.

Installing the QBox into the sheathing does not require a pilot hole. However, if an attachment screw for the QBox is to be installed into a rafter, a 7/32" pilot hole is required.

**No rafter zone**

For easiest installation, DO NOT install QBox directly over a rafter.

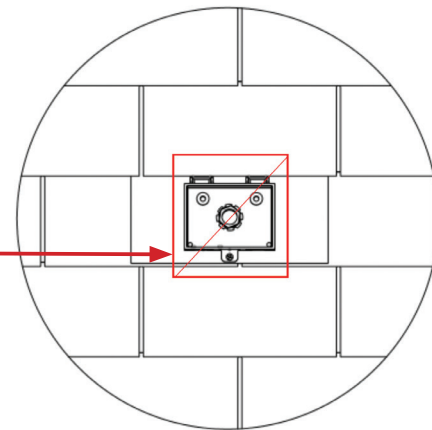

**WARNING:** These products are NOT designed for and should NOT be used to anchor fall protection equipment.



# IV. Installation

**Tool Specs:** Shingle ripper bar, lumber crayon, 1" spade pit, hand broom, caulk gun, appropriate sealant, adjustable wrench with 1.25" capacity, 1/2" nut driver, #3 phillips screw driver.

**Side Mount Conduit Exit:** For side mount conduit exit, where transition wires leave the QBox from the side of the box, skip steps 3-5 and 8-10.



**Remove Nails:** Use roofing bar to break seals between 1st and 2nd and 3rd shingle courses. Be sure to remove any obstructing nails to allow correct placement of the QBox.



**Slide the QBox flashing up underneath the second course of shingles, so that the bottom edge of the flashing does not overhang the front edge of the shingle and the top edge extends up under the third course of shingles.**



**Mark Conduit Location:** If not using attic conduit exit, skip to step 6. Otherwise, mark the location to drill the conduit pass-through with a lumber crayon or other marking device.



**Drill Conduit Hole:** Remove QBox flashing and drill 1" hole at location marked in Step 3. Use either a spade bit or hole saw. Avoid all electrical components on underside of deck in the attic.



**Clean:** Clean debris from roof to ensure the flashing is as flat as possible against the roof surface and clean for adhesion.

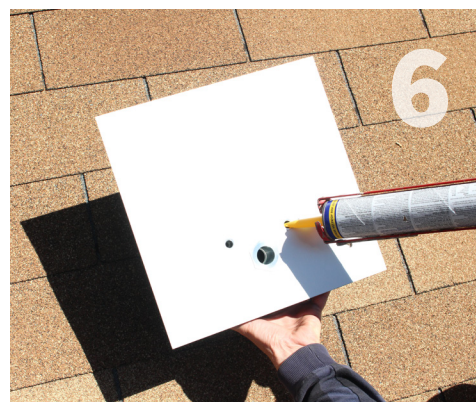

**Caulk:** Fill the fastener holes with appropriate sealant.

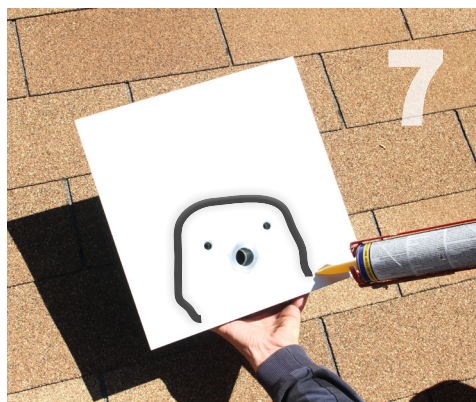

**Optional Caulk:** Apply an upside down U-shaped bead of sealant to the underside of the flashing before insertion. Do not use excessive sealant.

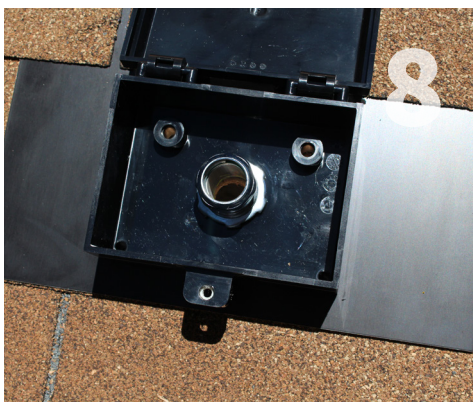

**Reinstall Flashing:** Reinstall the QBox assembly such that the conduit fitting in the center of the box aligns with the hole you created in step 4.



**Install Conduit:** Install your conduit through the QBox and the roof. Loosen the compression nut to install conduit, but don't remove.

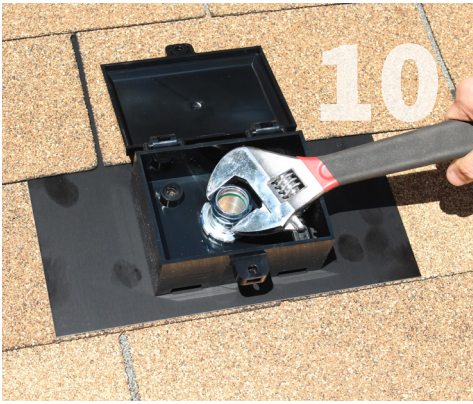

Finish Conduit Attach: Tighten conduit hub to lock conduit in place. The cut edge of the conduit should be flush with the top of the hub nut or 1/6" above it. This will hold the QBox flashing in place when securing it to the roof.



Secure to Roof: Screw the anchor bolts with sealing washers through the mounting holes and into the roof sheathing securing the QBox to the roof. No pilot hole is required.



Close Lid: Close and thread the bolt into the nut by hand. Then using a #3 Phillips drive, turn bolt until the top and bottom tabs securing the bolt are flush.

# V. Wiring

To maintain the QBox Type 3R rating for wet locations, all attached conduit hubs and cord grips must be raintight or suitable for wet locations and be listed to the Standard for Conduit, Tubing and Cable Fittings, UL 514B. The conduit hubs and cord grips can be installed along any of the sidewalls of the QBox. The drill starter along the outside of the QBox will ensure that the connectors are centered vertically on the unit. The QBox does not come with conduit hubs or cord grips due to site-specific needs. It is the responsibility of the installer to specify the proper conduit or cord grip products for the installation. Follow the installation instructions from the conduit hub and cord grip manufacturer and follow all National Electrical Code, ANSI/NFPA 70 wiring methods and guidelines.

The QBox is nonconductive and therefore does not need to be grounded. However, that also means the box cannot be used to maintain an electrical bond between fittings. Ensure all proper jumpers or other bonding mechanisms are in place per NEC.

The DC input and DC output circuits are isolated from the enclosure and that system grounding, if required by section 250 of the National Electrical Code, ANSI/NFPA 70, is the responsibility of the installer.

The Photovoltaic System Grounding shall be installed per the requirements of Sections 690.41 through 690.47 of the National Electrical Code, ANSI/NFPA 70 and is the responsibility of the installer.

The ground terminal for bonding is not provided. Grounding will need to be provided as part of the final installation and compliant with the National Electric Code and local electrical codes. When installing a conduit hub to the QBox that is intended for connection to a rigid conduit system, install the hub to the conduit before the hub is connected to the enclosure.

To maintain the QBox's 3R rating, the enclosure's top hinged cover must be completely closed to the enclosure's base. In addition, all wires should be pushed down and away from the cover so it closes freely without resistance.

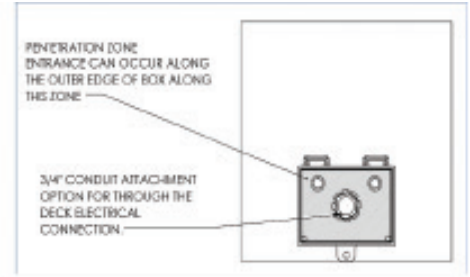

 **WARNING**

PV modules produce lethal levels of electricity when exposed to light. PV modules cannot be de-energized unless all light sources are removed. Disconnect all wires from the PV system prior to installing or servicing the QBox. Failure to do so could result in electric shock leading to personal injury or death.

 **WARNING**

Before wiring of the QBox, ensure all cables are de-energized. Do not work with energized electrical cables. Energized electrical cables are a shock hazard.

 **CAUTION**

In order to maintain warranty and Type 3R rainproof rating of the enclosure the lid must close freely without interference from the wires. Failure to properly close the lid can lead to excessive water ingress leading to an electrical short and possibly a

**Tool Specs:** Appropriate rain tight conduit fittings and cord grips, hole saw, adjustable crescent wrench, wire strippers and cutters.

**Configurations Shown:** The following installation steps are for a single string transition using cord grips for the home run cables from the PV system. There are two ways to transition wiring from the QBox. The first is through the attic using the QBox's pre-installed, conduit pass-through with the patented Elevated Water Seal Technology™ (steps 4-7). The alternative method is to leave the QBox from the side (steps 8 & 9).

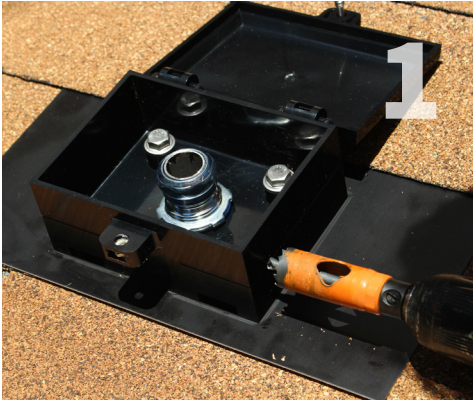

**Holes for Cord Grips:** Use the drill starter along the perimeter of the box to guide your hole saw. Hole size is specified by the cord grip or conduit hub manufacturer. Clean off all burs.

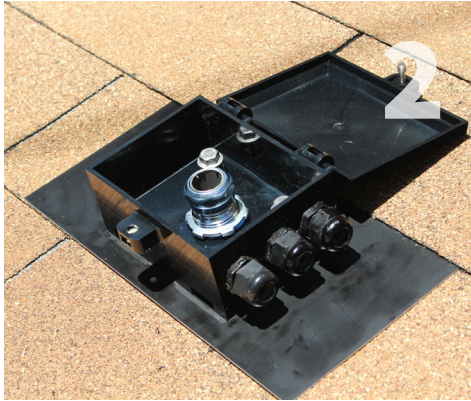

**Attach Cord Grips:** Install the cord grips and tighten them to the enclosure to make the watertight connection. Ensure all wires are de-energized. Properly label the wires following NEC guidelines.



**Install PV Wires:** Pull PV system wiring through the cord grips and tighten the cord grips to seal around the wires making a watertight connection. Ensure each wire has a minimum of 6" of lead inside the box per NEC requirements.

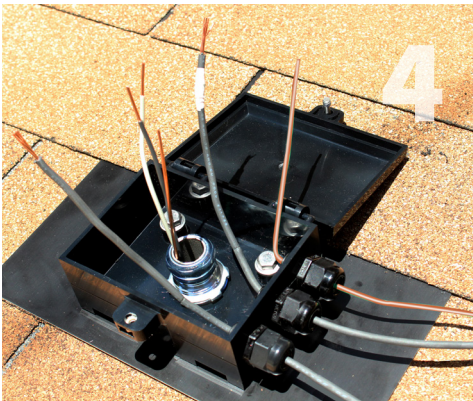

**Install Output Wires:** Pull the transition wiring into the QBox, label all wires appropriately, and strip sheathing from the end of all wires per instructions found in Section VI. Ensure each wire has a minimum of 6" of lead inside the box.



**Connect Wires:** Install the supplied wire nuts to achieve one of the approved wiring combinations outlined in Section VI.



**Install Grommet:** Slide the grommet over the wires and push it down into the conduit such that it extends over the cut edge and locks into itself. The grommet should extend over the top and be secured to the conduit. It should not be loose.

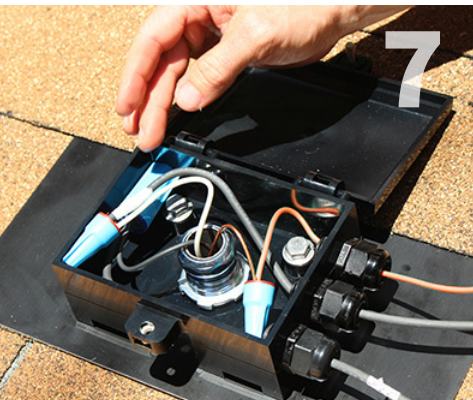

**Push Wires Into Box:** Push wires down into the box and away from edge. Lid should close freely without wire interference. Failure to do so will prevent proper rainproofing of the enclosure, voiding the warranty and possibly leading to a short. Secure the lid per step 12 in section IV.

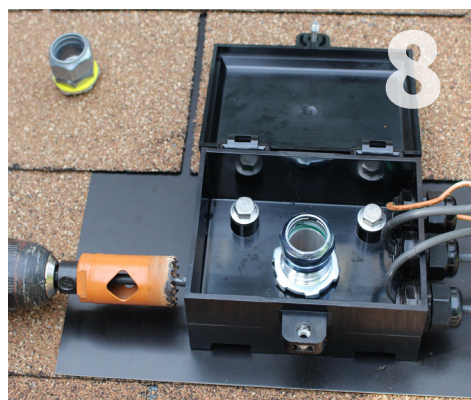

**Holes for Conduit:** Use the drill starter along the perimeter of the box to guide your hole saw specified by the conduit hub manufacturer. Clean off all burs. Attach the conduit to the box.

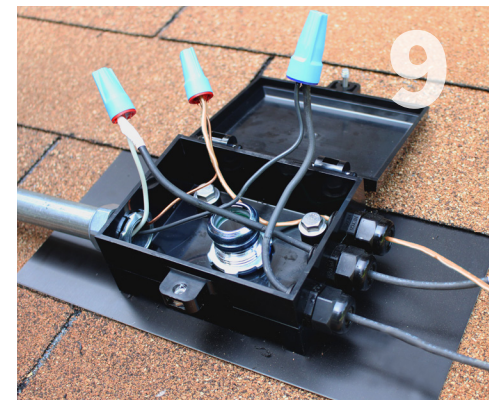

**Connect Wires:** Pull min 6" of transition wiring into the QBox, label all wires, and strip sheathing from the end of all wires per instructions found in Section VI. Follow steps 5 & 7.

# VI. Wiring Diagrams and Proper Use

The QBox can be used to transition a single string, two parallel strings, or two combined strings. Below are wiring diagrams for all the approved use cases. All wires are to be copper conductors with insulation rated to 90°C or higher. Maximum size of incoming PV string wires is #10 AWG. Maximum size of outgoing branch circuit is #8 AWG. Ground wires can be green or bare according to the NEC.

Single String

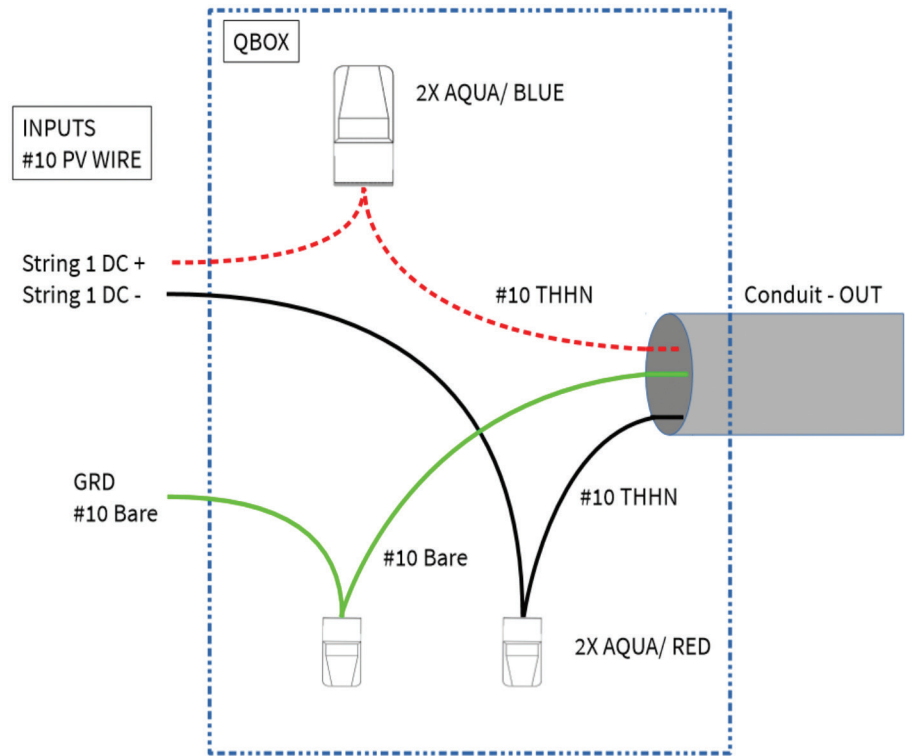

Two Parallel String

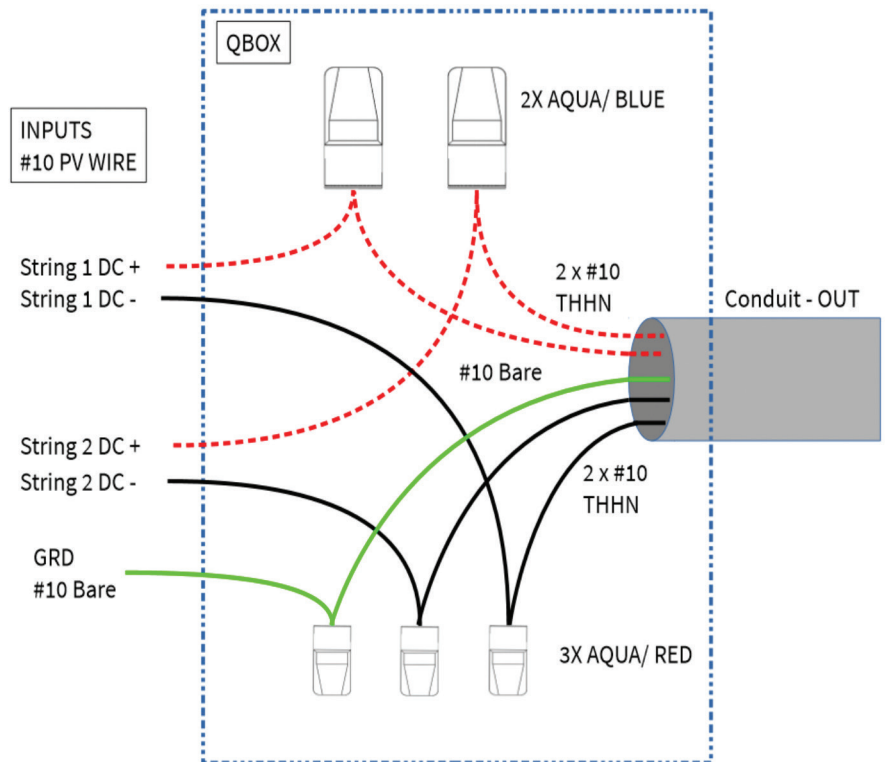

## Two Combining Strings

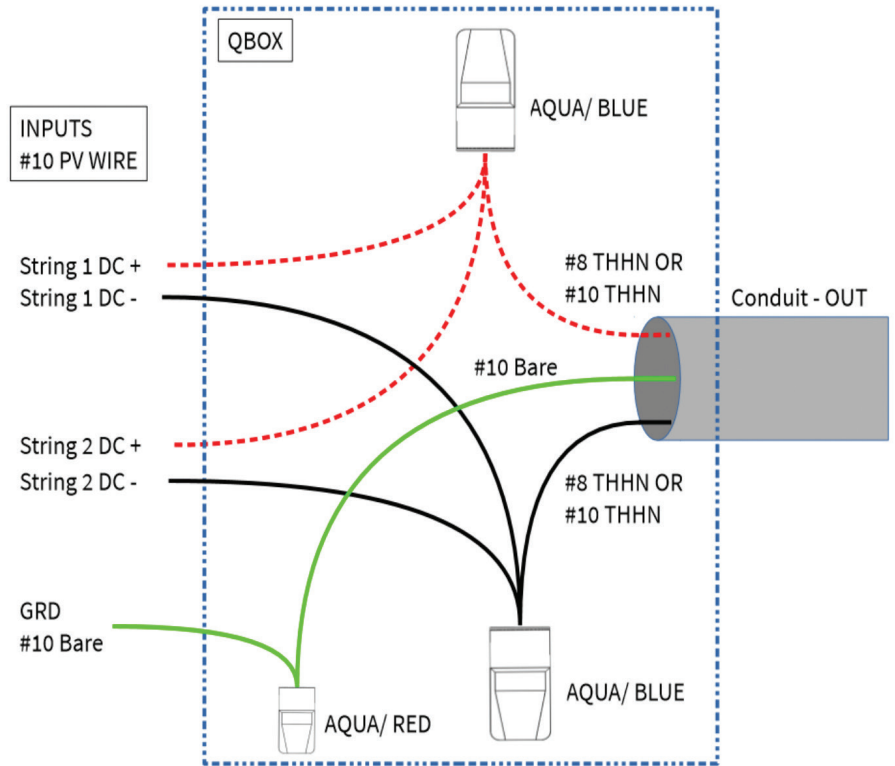

## WIRE NUT – AQUA/ RED & AQUA/BLUE INSTALLATION INSTRUCTIONS

IMPORTANT: Turn off power before installing or removing connector.  
Product to be used in accordance with local and national codes.

1. AQUA/RED ONLY: **Strip wires 7/16" (11.1mm).**
2. AQUA/BLUE ONLY: **Strip wires 3/4" (19.1mm).**
3. Align any frayed strands or conductors.
4. Pre-twisting is unnecessary. Place stripped wires together with ends of insulation even.
5. Twist connector onto wires pushing firmly until hand-tight. Do not over torque.
6. Wipe sealant in and around conductors and connector opening while tightening. Do not reuse.

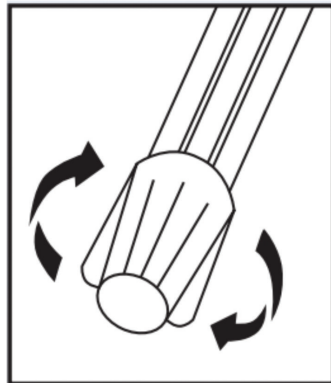
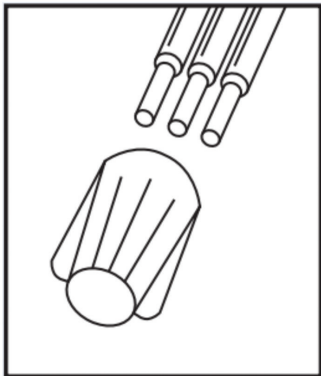

WARNING

Before wiring of the QBox, ensure all cables are de-energized. Do not work with energized electrical cables. Energized electrical cables are a shock hazard.

# VII. System Specifications and Ratings

## QBox Specifications:

- Maximum Voltage: 600 Volts
- Maximum Current: 40 Amps
- Allowable Number of Strings: 2
- Allowable Wire: 10AWG or 8AWG
  - » Inputs: 12 AWG or 10AWG
  - » Outputs: 12AWG or 10AWG or 8AWG
- Enclosure Rating: Type 3R
- Roof Slope Range: 2.5:12 - 12:12
- Attic Conduit Pass-Through: ¾" EMT
- Max Side Wall Conduit Size: ¾"
- Dimensions:
  - » Box: 5.76" W x 5.4"D x 2.6" H
  - » Flashing 12"W x 12"D
- Ambient Operating Conditions: -35°C - 75°C
- Testing has shown that there is a 25.5°C increase in box temperature over ambient when wind speed is less than 1 mps and solar irradiance in plane of array is 1000 W/m<sup>2</sup>. Temperature rise due to irradiance must be considered when calculating ambient operating conditions.
- Compliance:
  - » Wire Nuts: UL 486C, UL486D
  - » QBox: UL1741
- System Marking:



- Periodic Re-inspections: If re-inspections yield loose components, loose fasteners, or any corrosion between components, components that are found to be affected are to be replaced immediately.



925-478-8269 | 2700 Mitchell Dr. | Walnut Creek, CA 94598

[www.quickmountpv.com](http://www.quickmountpv.com) | [tech@quickmountpv.com](mailto:tech@quickmountpv.com)

