

# Off Grid Inverter

## User and Installation Manual

PICOGLF50KW384V240VS



Please strictly abide by all warning and operational instructions in this manual and on the machine. Keep this manual for future servicing information or concerns. Read all safety and operating instructions to ensure personal safety and integrity of the product. Failure to do so can damage the equipment or cause possible injury.

**AIMS Power, Inc.**

# Content

1 Safety Instructions.....	6
2 Production Introduction.....	9
2.1 Summarize.....	9
2.2 Product Introduction.....	9
2.3 Technical Description.....	10
2.3.1 Working Principle.....	10
2.3.2 Derating.....	11
2.3.3 Product Feature.....	12
3 Inverter Unpacking.....	13
3.1 Unpacking Check.....	13
3.2 Identify Inverter.....	13
4 Installation Procedure.....	14
4.1 Prepare Installation Tools.....	14
4.2 Installation Steps.....	15
5 Installation.....	16
5.1 Installation Site Required.....	16
5.2 Installation Direction.....	17
5.3 Installation of Inverter.....	17

5.4 Notice.....	18
6 Electrical Connection.....	19
7 LCD Panel Operating Instructions.....	21
7.1 LCD display description.....	21
7.2 Indicator of LED light function.....	21
7.3 Fault Code.....	22
7.4 LCD Display Interface Overview.....	22
8 LCD Panel Operating Instructions.....	23
9 Malfunction and Troubleshooting.....	28
9.1 Troubleshooting.....	28
9.2 Maintenance.....	29
10 Warranty Conditions.....	30
11 Technical Parameters .....	32

## **Preface**

### **Manual Instruction**

This manual includes the description regarding the troubleshooting in process of transportation, installation, maintenance and operation of the following PICOGLF-xx inverters:

- PICOGLF50KW384V240VS

For convenience, this document will reference PICOGLF50KW384V240VS Off grid inverter as simply “inverter” for short. When information about each inverter type is introduced in detail, the specific model of inverter will be named.

### **Target Reader**





This manual applies to the inverter installation technician and professional engineers, and end user of inverter and LCD interface operation.

### **Use of the Manual**







Please read this manual carefully before starting installation and operation. Please keep this manual for operation and maintenance in future. The content in this manual will continue to be updated and amended, but unavoidably discrepancy in interpretation or understanding will still exist.

### **Symbols Used**

The following safety symbols may be used in this manual, they represent the following meanings:

Safety Symbol	Meaning
 <b>Danger!</b>	Ignoring this security warning may lead to serious accident or injuries.
 <b>Warning!</b>	Ignoring this security warning may lead to serious accident or injuries, equipment damage or major business interruption risk.
 <b>Notice!</b>	Ignoring this security warning may cause moderate injury or accident, moderate damage to the equipment or risk of business interruption.
 <b>Note!</b>	The content is the body of the additional information.

### Symbols on the inverter:

Symbol	Meaning
	Ground Protection
	Refer to related instructions
	Cannot discard the inverter together with every day waste.
	Beware of dangerous electrical voltage. The inverter operates at high voltages!
	CE mark The inverter complies with the requirements of the applicable EC guidelines.
	SAA mark The inverter complies with the requirements of the applicable Australia guidelines.
	UL mark The inverter complies with the standard of UL1741.



CSA mark

The inverter complies with the standard of CSA22.2.

## 1. Safety Instructions

For electrical and electronic equipment, as well as the process of installation, commissioning, operation and maintenance thereof, safety is of critical importance. Incorrect or negligent operation of this equipment can cause serious harm, death, or damage to the inverter. To reduce the risk of harm or injury and any equipment damage, operation and maintenance processes must be followed at all times. Please pay attention to all “Danger” and “Warning” notices as well as any other safety tips in this manual.



### **Warning !**

All the installation and operation of PICOGLF-XX series inverter must be completed by professional technician. Any damage to the equipment caused due to failure to comply with the descriptions in this manual in installation or operation will be beyond the scope of the company's quality guarantee and/or warranty.

### **Before installation**



### **Notice !**

Check the inverter for any damage during transportation. If a problem is found please contact AIMS Power, Inc. or the transportation company used immediately.

### **Installing**

**Before installing inverter, make sure the inverter not have electrical connections and electricity.**



### **Danger !**

The solar cell arrays should be covered with opaque materials when installing the photovoltaic arrays during the day, otherwise the solar cell arrays will

generate high voltage, potentially causing personal injury or death.

## **Warning!**

If the inverter is installed in a non-ideal environment, it will affect the performance and may potentially cause damage to the inverter.

DO NOT install the inverter in any location with flammable material.

DO NOT install the inverter in any location with explosive material.

DO NOT install the inverter in any location vulnerable to lightning strikes.

DO NOT install the inverter in humid or damp location.

## **Electrical connections**

### **Warning!**

All the operating and wiring work should be operated by professional electrical or mechanical engineer.

### **Warning!**

Inverter should be installed in an upright position. Ensure that the inverter is

### **Warning!**

Please DO NOT open any breakers until all electrical connections are completely and securely fastened.

### **Notice!**

All installation procedures and practices must adhere to local and national standards.

### **Notice!**

Ground the inverter using appropriate conductor size, providing adequate short circuit protection.

### **Notice!**

Any cable connecting to the inverter must meet all local and national electrical standards.

## **Running**



## **Danger !**

DO NOT disconnect DC input to inverter while there is live AC output. You will need to turn off the inverter start switch, then break AC output breaker, ensure that there is no voltage on AC side, then break DC connection.



## **Danger !**

DO NOT connected any terminal connectors under inverter charged state!  
DO NOT open the cover plate under inverter charged state!



## **Notice !**

DO NOT touch any internal components while the inverter is in operation.

## **Maintenance**



## **Danger !**

Maintenance work must be completed by professional electrical technician.



## **Danger !**

Before performing any maintenance, break Start switch, AC side breaker, then break DC side breaker, after waiting 5 minutes, measure both DC and AC terminals to ensure there is no remaining voltage.

## **2. Product Introduction**

### **2.1 Summarize**

Our PICOGLF series off grid inverter is one of the most advanced DC to AC conversion products in the world. This inverter is designed to supply AC power to various electronic devices such as air conditioners, electric motors, refrigerators, fluorescent lights, televisions, electric fans and many other industrial power supply needs. It is suitable for use in areas without electricity, with backup batteries systems, or with solar, wind and other renewable energy systems. It has the main advantages of high quality sine wave AC output,



microcomputer control, and it is high efficiency with low no-load loss and zero pollution.

## 2.2 Production Introduction

### 2.2.1 Production Appearance



Figure2-1 Appearance of PICOGLF off grid inverter

Table2-1 Inverter appearance information table

No.	Name	Introductions
1	LCD display screen	Allows the user to check the inverter operating information and set some essential parameters of the inverter
2	Lock	The lock of inverter used to open and lock
3	PG Cable Glands	The input wire and output wire through this cable glands
5	Start switch	Used to start and break the inverter
6	Breakers	DC input breaker and AC output breaker
7	Connection terminals	Including DC input terminal; AC output terminal;
8	Name plate	Inverter basic parameters listed on the nameplate for basic information about inverter.

## 2.2.2 Product Name

The way of product naming, take PICOGLF50KW384V240VS for example:

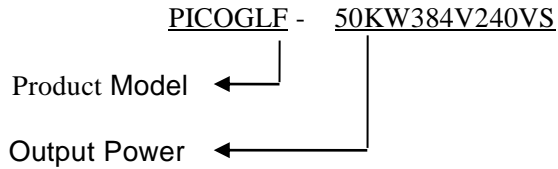

## 2.3 Technical Description

### 2.3.1 Working Principle

For the principles of PICOGLF series off grid inverter please refer to the schematic below.

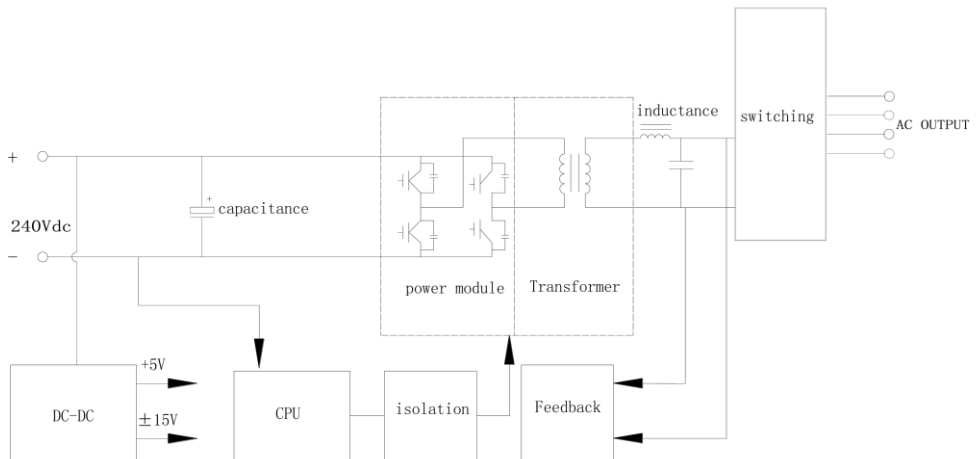

Figure2-2 Internal circuit structure diagram of PICOGLF off grid inverter

### 2.3.2 Derating

Inverter temperature derating curves in below

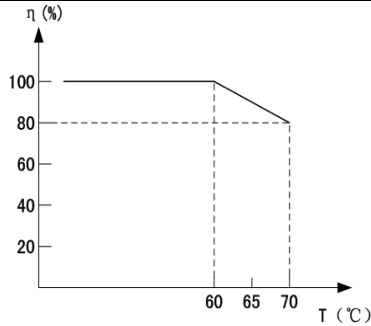

Figure2-3 Inverter temperature derating curve

$$\eta = \left( \frac{P_{out}}{P_{nom}} \right) \times 100$$

T is environment temperature

P<sub>out</sub> is the off-grid inverter actual max. output power

P<sub>nom</sub> is the off-grid inverter allowed max. output power

### 2.3.3 Product Feature

- ◆ Using the sixth generation efficient IPM intelligent module from Mitsubishi, providing high efficiency and stable performance. It with powerful protection function for short circuit, over load and over temperature which is more safe and reliable. It's service life can up to 15-20 years or more.
- ◆ Intelligent, modular, and simple structure design, making it very easy and convenient for maintenance.
- ◆ There are two kinds of start mode: Step Down Voltage Start and Variable Frequency Start. Customer can set start mode per type of load.
- ◆ The output frequency 50Hz/60Hz can be set via LCD panel.
- ◆ The output voltage can be set between -40 % to +20 % of rated voltage. The accuracy of output voltage is very high, less than 1%.
- ◆ The DC input voltage range, over-voltage point, under-voltage point, over-voltage recovery point, under-voltage recovery point and under voltage recovery time can all be set via the LCD panel. Convenient for increasing or reducing the quantity of batteries and solar panel in the future.
- ◆ Using SVPWM algorithms, this unit has high conversion efficiency, high instantaneous power and low losses providing efficiency > 94%.

- ◆ Pure sine wave output, with good transient response less than 50MS
- ◆ Low frequency transformer, which ensures the AC bus bar and DC bus bar are completely isolated to avoid interference and provides minimal idle consumption.
- ◆ Powerful data display and fault instruction function. LCD can display the DC input voltage, output frequency, phase voltage, phase current, AC bypass input voltage, output power KWH, time and date, temperature, fault code display.
- ◆ The DC input voltage can be set per customer's requirement. Input voltage range can be selected from 200-600v. This wide voltage input allows our inverter to not only work with batteries but any direct DC sources that operate within this range.
- ◆ AC bypass input function optional: Battery Power Priority or AC Bypass Priority work mode can be set.
- ◆ RS485 remote monitoring function optional
- ◆ External solar charge controller available
- ◆ European CE (EMC and LVD) certification, accredited by Australian CEC, ERAC energy network.

### **3. Inverter Unpacking**

#### **3.1 Unpacking Check**

This product has been tested and checked carefully before transportation, but damage may be caused during transportation, therefore, the product should also be checked carefully before installation.

- Please check whether inverter outer packing is in good condition;
- After unpacking, please check whether the equipment is in good condition;
- Check whether all the parts are correct and in good condition according to the packing list

If any damage is found, please contact AIMS Power, Ins. or the transportation company. Please keep well the photos taken at the damaged parts and we'll provide you with best and fastest services.

### 3.2 Inverter Identification

There is nameplate on the side of inverter, the nameplate shows the inverter model, some important parameter info, and certificate mark.

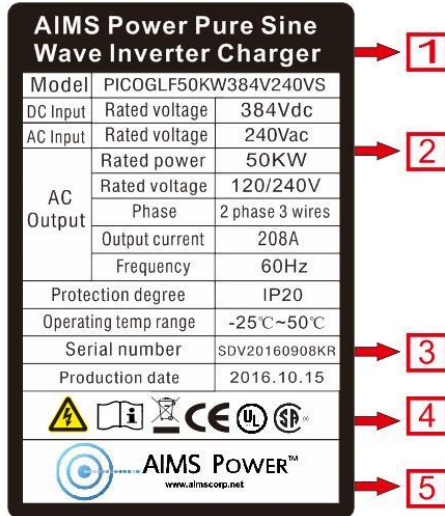

Figure3-1 Inverter nameplate

NO.	Description
1	AIMS Power Logo and product name
2	Inverter model and parameter information
3	Inverter factory number
4	Certificate and safety signs, concrete meaning as “Preface”
5	Company and Address

Table3-1 Nameplate information table



**Note!** Photos are for reference only, please adhere to the original products!

## 4. Installation Procedure

## 4.1 Prepare Installation Tools

Before installation, some preparation is necessary.

Inverter and wire installation will need some form of the following tools.



Sketch map	Name	Recommend specification	Function
	Wire crimpers	6~50mm <sup>2</sup>	Used for crimping input and output terminals connected to the wires
	Cross screwdriver	Φ8	Used for the input and AC output wires installation

Table4-1 Installation tools list

## 4.2 Installation Steps

Tools ready, follow these steps to install

Installation steps	Installation instruction	Reference chapters
1	Before installation, check whether the inverter is in good condition;	
	Confirm whether installation tools and spare parts are complete and in good condition	4.1
	Confirm that install location meets all requirements and guidelines	1
2	Read manual and any/all "safety instructions" thoroughly	1
	Choose the best installation location	5.1
3	Install Inverter	5.2
	Electrical Connections	
4	DC Wiring	6.1
	AC Wiring	6.2
	Parameter Configuration	10
5	Troubleshooting	9

Table4-2 Installation process table

## **5 Installation**

### **5.1 Installation Site**

Inverter installation site environment is very important to the safe operation, performance, and life of the inverter.

- All installation procedures must comply with local and national electric standards.
- Do not install the inverter in a flammable or explosive place or a place where the flammable or explosive materials are stored.
- Do not install the inverter in a place where there is a risk of explosion.
- Do not install the inverter in places where the inverter is vulnerable to lightning strike.
- Do not install the inverter in a high salt spray environment
- Inverter installation site must be well ventilated otherwise the inverter will not work properly.
- Inverter protection level is IP20 - Protected from touch by fingers and objects greater than 12 millimeters but not from liquids
- If the inverter is installed indoor, keep away from windows
- The installation location selected should be solid enough to support the inverter weight for a long period of time.
- The install location must be clean and the ambient temperature must be maintained within -25 to +50°C.
- Inverter installation site relative humidity should not be more than 95%, water vapor may corrode inverter and damage the internal components
- The inverter must be installed in a place convenient for observation and maintenance
- DO NOT install the inverter in living area, the inverter will produce some noise when running, influence daily living.

## 5.2 Installation Direction

- The inverter should be installed vertically.
- Do not install on uneven ground.
- Never install the inverter horizontally.
- The installation place of inverter should be convenient for operation and reading out of the LCD displayed information
- Do not install the inverter in a place where children can touch.
- The inverter uses fan cooling. Therefore, the installation site selected should ensure the maximum installation spacing between the inverter and fixed objects or any other nearby inverters to ensure good ventilation. Keep enough space in front of inverter to easily access LCD/Control panel

## 5.3 Installation of Inverter

5.3.1 – Check that front panel breakers are in "OFF" state and there are no short circuits

5.3.2 – DC input cable must be through from the DC input terminals, correctly connect to the positive and negative pole of the machine, this cannot be reversed.

5.3.3 – NEVER connect any input sources to output load terminals.

5.3.4 – The connection cable between the battery and inverter should be as short as possible, harmonic leakage current from cables can be harmful to inverter and other system equipment.

5.3.5 – System grounding terminal must be grounded, making the ground wire's length as short as possible. Do not connect any welding machine, motor or other high current device to system common ground. Ensure all system's ground wires are separately laid out from other high current electrical equipment.

5.3.6 – Ensure correct polarity, especially when connecting high voltage circuits

5.3.7 – Turn on the DC input breaker, if the breaker happens to the trip the first time, it's a normal phenomenon due to the starting capacitor charging.

5.3.8 –DO NOT turn off DC input breaker on the inverter under load, this will cause DC input breaker damaged.

5.3.9 When the machine shows MOD or overload fault alarm, turn off the DC



input breaker to restart the machine.

5.3.10 Put the inverter in well ventilated area away from sunlight, confirm that distance between the inverter and any wall is greater than 30cm.

5.3.11 DO NOT block air vents. If it is discovered that the vents are blocked, please clear any obstruction immediately.

5.3.12 If temperature starts to rise when the inverter is running normally, check to see if the fan is still operating correctly. If it is not, contact AIMS Power technical support immediately (The starting temperature of the fan is 45°C).

5.3.13 It is recommended to turn on the output circuit breaker first, then turn on start switch. Making the inverter starting load can effectively avoid the damage of large inrush current to the machine.

5.3.14 DO NOT connect ground wire (PE) of cabinet and neutral wire (N) together.



### Note!

DO NOT break the DC Input Breaker often, otherwise it will cause will cause DC input breaker damaged. If you want to shut down the inverter, just need turn off the AC output breaker and Start switch. If you must turn off the DC input breaker, first turn off the start switch, then AC Output Breaker to make inverter stop working, then turn off the DC Input breaker.



### Notice !

Never connect multiple inverters with parallel output!



### Danger !

Ensure that cables are not charged before operation!

## 5.4 Notice

5.4.1 – All operation of equipment must be done by professionals. Please remember to remove any metal jewelry on hands or wrists while operating

5.4.2 – The inside cooling fan of the machine is controlled by temperature, it's a normal phenomenon that the fan is not running when inverter first starts or taking

on smaller loads. The fan only will run when cabinet internal temperature exceeds 45 °C.

5.4.3 – DO NOT open the cover of cabinet when the inverter is running, doing so could cause electric shock!

5.4.4 – DO NOT change any circuitry or wiring that has been preinstalled on the inverter.

5.4.5 – It is a normal phenomenon that the inverter warms up during nominal function. Keep the environment around inverter cool and clean, ensuring proper ventilation at all times.

5.4.6 – DO NOT touch any internal CMOS components when the circuit is powered on.

5.4.7 – After connecting all wires, please carefully check voltage value, polarity, and grounding.

5.4.8 – Even if all switches on the panel are OFF, the inverter's charging capacitor is still electrified, DO NOT touch.

5.4.9 – When connecting an AC input source to the inverter that is shared with other inductive loads, it is best to allocate an additional 30% of the power margin to ensure reliable power supply to the inverter.

## 6 Electrical Connection

The electrical connection should be carried out immediately when the installation is completed. When making electrical connection, special attention should be paid to the following operating instructions:



### Warning!

- All electrical connections must meet local/national code and regulations.
- Only qualified electrical technicians can perform the installation of this unit.
- Incorrect wiring or operation may cause personal injury, casualties or permanent equipment damage.
- Before making any electrical connection, please make sure that the circuits being worked on are uncharged!

- Always ground the system properly, using appropriate conductor and providing necessary short-circuit protection to ensure safe operation.
- DO NOT turn on any breakers before all connections are secure and complete

**6.1 Connecting Terminals of inverter**

The input and output terminals are installed in the bottom of the inverter and include DC side input terminals and AC side output terminals.



Figure6-1 Connection terminals on inverter

Table 6-1 Terminals Description

Terminals	Description
+	DC positive input terminals
-	DC negative input terminals
L1, L2, N	AC input terminals, connect with AC grid
L1, L2, N	AC Output terminals, connect with AC load
PE	Earth Wire



**Warning!**

DO NOT connect inverter with reverse polarity!

## 7. LCD Panel Operating Instructions

### 7.1 LCD display description

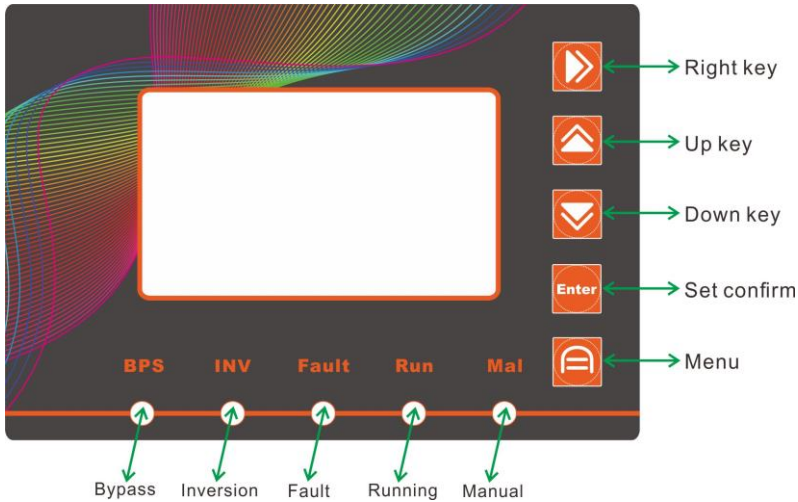

### 7.2 Indicator of LED light function

There are 5 LED lights on the panel: BPS, INV, Fault, Run, Mal.

LED Indicator	Name	Color	Instructions
BPS	Bypass		AC bypass priority mode, it indicates the AC grid input condition.
INV	Running light	Green	Battery priority mode, it indicates the battery supply condition.
Fault	Faulty light	Red	System fault.
Run	Power light	Blue	Inverter running. Indicates the inverter is working normally.
Mal	Manual		Variable frequency mode, the inverter work with variable frequency mode running

Table7-1 LED Indicator Direction

## 7.3 - Fault Code

DCU OVER	DC over-voltage
DCU UNDER	DC under-voltage
OVER LOAD	Current over-load
MOD	Module error

## 7.4 - LCD Display Interface Overview

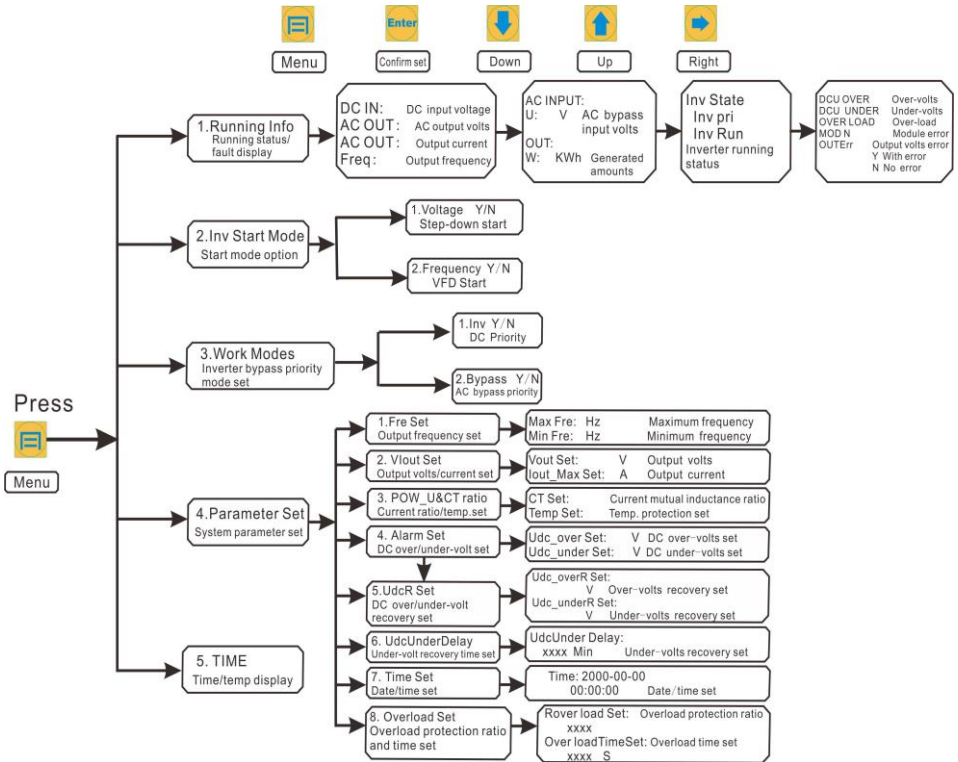

**8. - LCD Panel Operating Instructions**

Inverter power on, the first interface display parameter, press “down” key to display as following 4 item

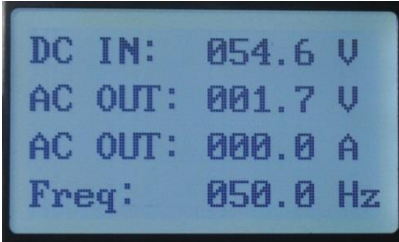

<b>DC IN</b>	DC input voltage display
<b>AC OUT</b>	AC output voltage display
<b>AC OUT</b>	Output current display
<b>Freq</b>	Output frequency display

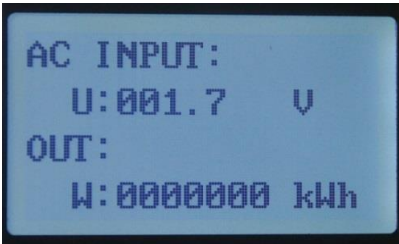

<b>AC INPUT:</b>	AC bypass input
<b>U: V</b>	Bypass phase voltage
<b>OUT:</b>	Total generated amounts
<b>W: KWH</b>	Generated amounts

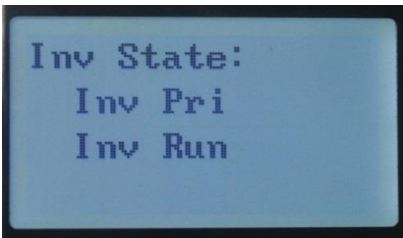

**Inv State:** Inverter working state

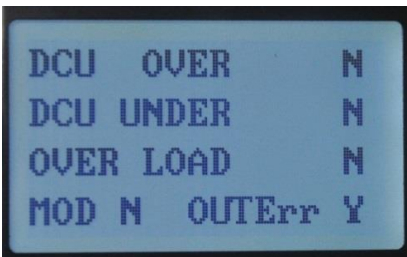

<b>DCU OVER</b>	DC over-voltage
<b>DCU UNDER</b>	DC under-voltage
<b>OVERLOAD</b>	Over-load
<b>MOD</b>	Module error
<small>(Fault display: "N" indicate no error, "Y" indicate with error)</small>	
<b>OUTErr</b>	Output voltage unbalance

- This error is only for inverters with 3 phase output, single phase output units do not show this error

- ◆ Fault alarm can be divided into automatic recovery and non-automatic recovery: When the LCD screen displays MOD error and overload, you will need to manually recover the unit: Turn off the DC circuit breaker, waiting until the LCD screen is completely extinguished, then turn on the DC circuit breaker; The inverter can then enter automatic recovery (the under-voltage recovery default setting is 10 minutes), this feature can be set per the customer needs.

## Keypad function

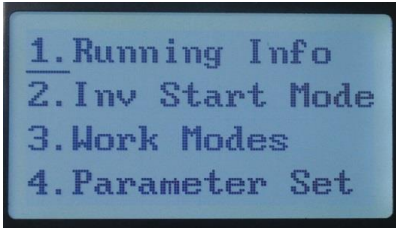

- |                          |                          |
|--------------------------|--------------------------|
| <b>1. Running Info</b>   | Running state display    |
| <b>2. Inv Start Mode</b> | Inverter Start mode      |
| <b>3. Work Modes</b>     | Working Mode             |
| <b>4. Parameter Set</b>  | System parameter setting |

Press “ 2. Inv Start Mode ” display as following

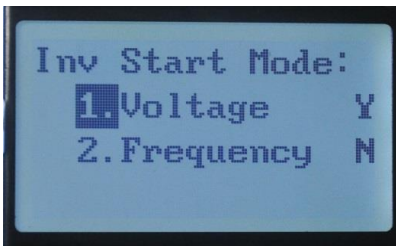

- |                     |  |
|---------------------|--|
| <b>1. Voltage</b>   | Constant frequency step-down voltage Starting mode |
| <b>2. Frequency</b> | Variable frequency starting mode                   |
| Y: YES              | N: NO  |

Press “ 3. Work Modes ” display as following

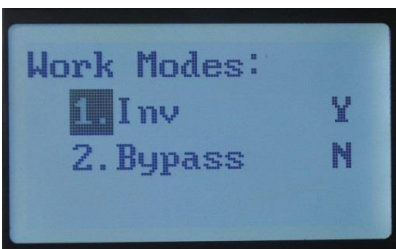

- |                  |                         |
|------------------|-------------------------|
| <b>1. Inv</b>    | Battery priority mode   |
| <b>2. Bypass</b> | AC bypass priority mode |
| Y: YES           | N: NO                   |

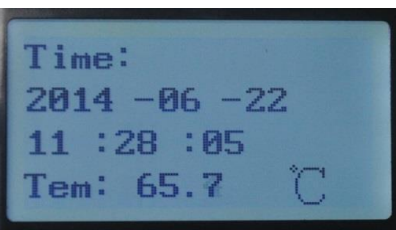

- |              |                                   |
|--------------|-----------------------------------|
| <b>Time:</b> | Display current time and date     |
| <b>Tem:</b>  | Environmental temperature display |

Press “4. Parameter Set” need to enter password.



**Note!** If you want to adjust the parameter setting, please contact the manufacturer ask for password

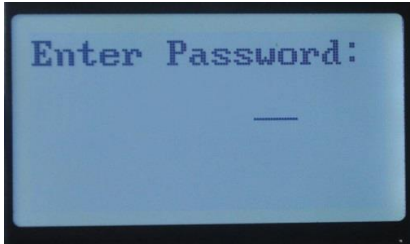

**Note!** When inverter is working, please do not adjust parameters setting. If you want to adjust the parameter settings, turn off inverter first, then make any necessary changes, and then turn the inverter back on.

The following settings only for professional technicians only, non-professionals should not change the parameters of the inverter. Changing these settings without the proper understanding or training will void any warranty and could cause damage to the inverter or injury to the user.



- 1. **Freq Set**            Frequency setting
- 2. **VIout Set**        Output voltage setting
- 3. **CT&Temp Set**    Current ratio setting and temperature Protection setting
- 4. **Alarm Set**        DC over-voltage and under-voltage setting

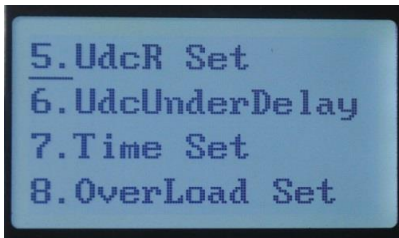

- 5. **UdcR Set**            Recovery setting of DC over-voltage and under-voltage
- 6. **UdcUnder Delay**    Default recovery time of under-voltage is 10 minutes
- 7. **Time Set**            Date and time setting
- 8. **Overload Set:**    Overload times and overload time setting



Press “ 1. Freq Set ” output frequency setting display as following

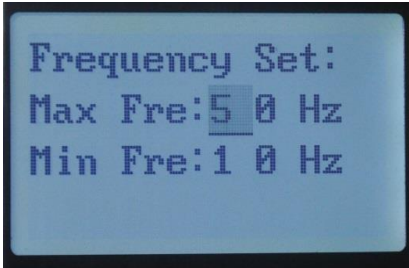

**Max Fre:** HZ      Recommend maximum output frequency setting between 30-100Hz  
**Min Fre:** HZ      The minimum frequency of output Starting can't less than 5Hz

Press “ 2. Vout Set ” output voltage and current setting display as following

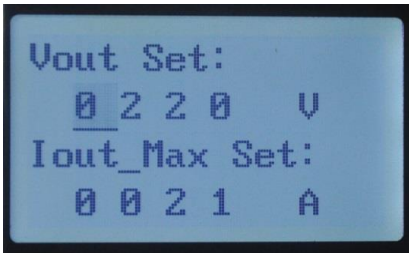

**Vout Set**      Output voltage setting  
**Iout -Max Set:**      Output current setting

**Notice:** Output Max Current default is set to the overload protection current value, it can't be adjusted past this point. Output voltage set not more than 20% of the rated power, if the inverter damaged caused by wrong settings is beyond the scope of warranty.

Press “ 3. CT&Temp Set ” Current and mutual inductance ratio and Protection temperature setting display as following

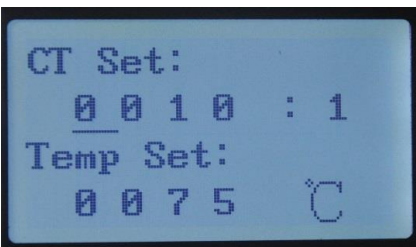

**CT Set:**      Current and mutual inductance ratio setting  
**Temp Set:**      Protection temperature setting

Press “4. Alarm Set” over-voltage and under-voltage setting display as following

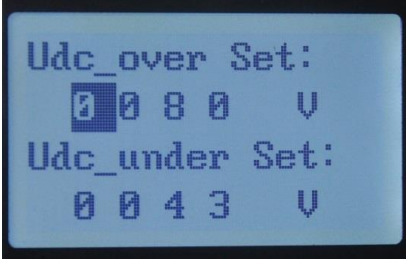

**Udc-over Set:** DC over-voltage protection setting

**Udc-under Set:** DC under-voltage protection setting

Press “5. UdcR Set” DC over-voltage and under-voltage recovery setting display as following



**Udc-over Set:** DC over-voltage recovery setting

**Udc-under Set:** DC under-voltage recovery setting

Press “6. Udc Under Delay” Under-voltage recovery time setting display as following

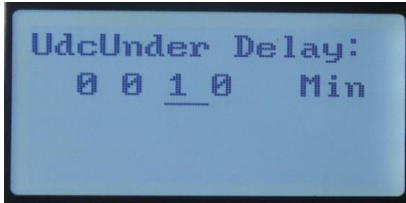

**Udc Under Delay:** Under-voltage recovery time setting

Press “7. Time Set” to display as following



**Time:** Display date and time setting

**Press “8. Over Load Set”**



**Rover Load Set:** Overload times setting

**Over load Time Set:** Overload time setting

**9 - Malfunction and Troubleshooting**

9.1 Troubleshooting

If the inverter experiences a fault or stops functioning, the malfunction LED will light up. The LCD will display current malfunction or stop condition, please refer form below for identified malfunction and troubleshooting.

Condition code	Name	Phenomena	Cause value	Troubleshooting
State 01	DC input voltage low	Inverter stopped working, malfunction disappeared, system restart automatic		Check battery output voltage, ensure the output voltage is within range of inverter.
State 02	DC input Over voltage	Inverter stopped working, malfunction disappeared, system restart automatic	DC input voltage higher than maximum input voltage of inverter	Check battery output Voltage or PV array, ensure the output voltage is within range of inverter.
State 03	Output overload	Inverter shut down, malfunction disappeared, restart again.	Load higher than rated output power of inverter.	Please ensure correct system design. This fault is usually caused by larger than acceptable load. Please reduce the power of load.
State 04	IPM fault	Inverter shut down, malfunction disappeared, restart again.		Please check if short circuit on AC output. If this fault appears frequently, please contact support

Table9-1 Stop condition and trouble shooting

## 9.2 Maintenance

To ensure PICOGLF series inverter is running nominally, it is suggested that a professional electronics technician perform regular inspection/maintenance every six months. Before opening the cover of cabinet maintenance, completely disconnect the power and shut down inverter according to the methods provided in this manual. Wait 10 minutes or longer to allow capacitors to discharge, then the qualified technician can proceed with maintenance.

### Items to inspect/maintain:



#### Warning!

Any operations must be done with whole system disconnected from any power source and discharged completely.

- Check humidity and clean any dust/debris from ventilation areas
- Check the inverter cable connections. If loose, tighten per the connection method of wire.
- Check for cable damage, especially the metal surfaces.

Parts	Check the contents	Solutions
Input and output terminals	Loose	Tighten
Input and output cable	Poor condition	Replace cable
Control board	Accumulation of dust and dirt	Use 392kPa-588kPa dry compressed air to blow off
Bus capacitor	Discoloration or smell	Contact AIMS Support
Radiator Fan	Not working	Contact AIMS Support
Inside of cabinet	Accumulation of dust and dirt	Use 392kPa-588kPa dry compressed air to blow off
Button cell	LCD doesn't display Time	Contact AIMS Support

### 10. Warranty Conditions

We offer a 3 year limited warranty.

The following cases are not covered under warranty:

**1 - DC polarity reverse. The inverter is designed without DC polarity reverse protection. A polarity reverse may severely damage the inverter.**

**2 - Wrong AC wiring**

**3 - Operation in a moist environment.**

**4 - Operation with an undersized generator or generator with unqualified wave form.**

To guarantee the best performance of inverter, the standby generator should be at least 150% of higher capacity than the inverter. AIMS Operating Corp., Inc. dba AIMS Power Warranty Instructions: This product is designed using the most modern digital technology and under very strict quality control and testing guide lines. If however you feel this product is not performing as it should, please contact us: techsupport@aimscorp.net or (775)359-6703.

If the product needs repair or replacement, make sure to keep your receipt/invoice, as that will need to be sent back along with the package and RMA# prepaid to AIMS. You have a full 3 year from date of purchase warranty. This warranty is valid worldwide with the exception that freight and duty charges incurred outside the contiguous 48 United States will be prepaid by customer. Except as provided above, AIMS makes no warranty of any kind, express or implied, including without limitation the implied warranties of merchantability and fitness for a particular purpose. In no event shall AIMS be liable for indirect, special or consequential damages. This warranty only applies to AIMS Power branded products. All other name brand products are warranted by and per their respective manufacturer. Please do not attempt to return non-AIMS Power branded products to AIMS Power.

## Product Registration Instructions

Please visit our website at [www.AIMSCorp.net](http://www.AIMSCorp.net) and click on the product registration link at the top of the page.

This will validate your warranty with AIMS Power and ensure that you get fast, expedited customer service if you need to repair or exchange your product.



## Warranty

If the inverter still does not function correctly after troubleshooting, Please contact AIMS power tech support at [Techsupport@aimscorp.net](mailto:Techsupport@aimscorp.net) (775) 359-6703 ex227

For additional products such as :

- Modified sine wave inverters
- Low frequency pure sine wave inverters
- Pure sine wave inverters
- Solar charge controllers
- Grid-tie inverters
- Inverter chargers
- Automatic transfer switches
- Customer sized cables
- Batteries
- Solar panels



AIMS Operating Corp. Inc. Aims Power warranty instructions.

This product is designed and is under very strict quality control and testing guidelines. If however you feel this product is not performing as it should, please contact us: [Techsupport@aimscorp.net](mailto:Techsupport@aimscorp.net) or (775) 359-6703 ex227.

We will do our best to resolve any of your concerns. If the product needs repair or replacement make sure to keep your receipt/invoice, as that will need to be sent back along with the package and RMA# to AIMS Power. You have a full 1 year warranty from the date of purchase. This warranty is valid world-wide with the exception that freight and duty charges incurred outside the continuous 48 States. User is responsible for return shipping. Except as provided above, AIMS makes no warranty of any kind, express or implied, including without limitation the implied warranties of merchantability and fitness for a particular purpose. In no event shall AIMS be liable for indirect, special or consequential damages. This warranty only applies to AIMS Power branded products. All other name brand products are warranted by and according to their respective manufacturer. Please do not attempt to return non-AIMS Power branded products to AIMS Power.

## 11. - Main Parameters

<b>Model</b>		PICOGLF50KW384V240VS
<b>Isolation mode</b>		Low Frequency Transformer
<b>DC Input</b>	Rated voltage (Vdc)	384V
	Rated current (A)	130.2A
	Voltage range (Vdc)	346-550VDC
<b>AC Input</b>	Rated voltage (Vac)	Split phase 120/240Vac
<b>AC Output</b>	Rated output power	50KW
	Output waveform	Pure Sine Wave
	Rated Voltage	120/240VAC±3%
	Phases	Split phase + N + PE
	Rated current (A)	208.3A(phase current)
	Frequency	60Hz
	Power Factor (PF)	>0.95
	Inverter Efficiency	>94%
	Display	LCD
	Voltage Accuracy	Load Balancing ≤1%, Unbalance Load ≤5%
	Waveform distortion rate	≤2%(Linear load), ≤3%(Nonlinear load)
	Dynamic Response	5%, ≤50ms(load 0~100%)
	Running mode	Working continuously
Electrical insulation	2000Vac, 1 Minute	
<b>Protection Function</b>	Overload Ability	150%, 5 seconds
	Protection	Input reverse polarity, under voltage, overvoltage, output over-current, short circuit, overheating etc.
	Cooling method	Fan-cooled
	Short-circuit protection	No automatic recovery, need to restart the machine
<b>Working Environment</b>	Noise ( 1 meter)	≤50dB
	Degree of protection	IP20(indoor)
	Working Altitude (m)	≤2000
	Working temperature	-25~+55°C
	relative humidity	0~90%, non-condensing
<b>Mechanical Dimension</b>	Depth* Width * Height	850x850x1300mm
	Weight (Kg)	420Kg
<b>Certification</b>	European CE(EMC & LVD), UL1741 & CSA22.2	