



**DPW** | SOLAR



**PREFORMED** LINE PRODUCTS



## **MULTI-POLE MOUNT - G2**

Assembly Instructions

**step-by-step  
assembly and installation**

# The Multi-Pole Mount - G2

## *A few words about the product*

The Multi-Pole Mount - G2 (MPM-G2) is designed to mount on 3, 4, or 6 inch SCH40/80 vertical steel pipe (installer supplied), and 4 x 4 inch square, or 5 x 4 inch rectangular horizontal tube. The goal of the MPM design is to limit the number of ground penetrations which helps reduce ground work and the associated labor costs.

Pipe size and foundation requirements are based on several factors including the array surface area, maximum design wind speed, exposure category, soil type, tilt angle and above-ground clearance.

For foundation and pipe size recommendations on a specific installation please contact us at:

Phone: 800-260-3792

Email: [info@dpwsolar.com](mailto:info@dpwsolar.com).

### WARNING

STAINLESS STEEL HARDWARE CAN GALL WHEN TIGHTENED TOO QUICKLY. INSTALLER SHOULD USE A SILVER GRADE ANTI-SEIZE COMPOUND PRIOR TO ASSEMBLING ANY STAINLESS STEEL HARDWARE. DO NOT USE AN IMPACT DRIVER. ALL OTHER DRIVER TYPES SHOULD BE SET TO LOW SPEED SETTINGS.

## *Assembly Instructions*

**WARNING:**  
Follow the procedures and precautions in these instructions carefully.

These instructions include information on assembling the product and are intended to be used by individuals with sufficient technical skills for the task. Knowledge and use of hand tools, measuring devices and torque values is also required.

Included in these instructions are various Notes, Cautions, and Warnings that are intended to draw your attention and assist in the assembly process and/or to draw attention to the fact that certain assembly steps may be dangerous and could cause serious physical injury and/or damage to components. Follow the procedures and precautions in these instructions carefully.

## *Required Tools*

- 1/2 inch wrench or socket for 5/16 inch module clamp hardware
- 3/4 inch wrench or socket for 1/2 inch hardware
- Torque wrench
- Ratchet wrench
- Ratchet extension bar
- 3 to 6 foot level
- Framing square
- Tape Measure

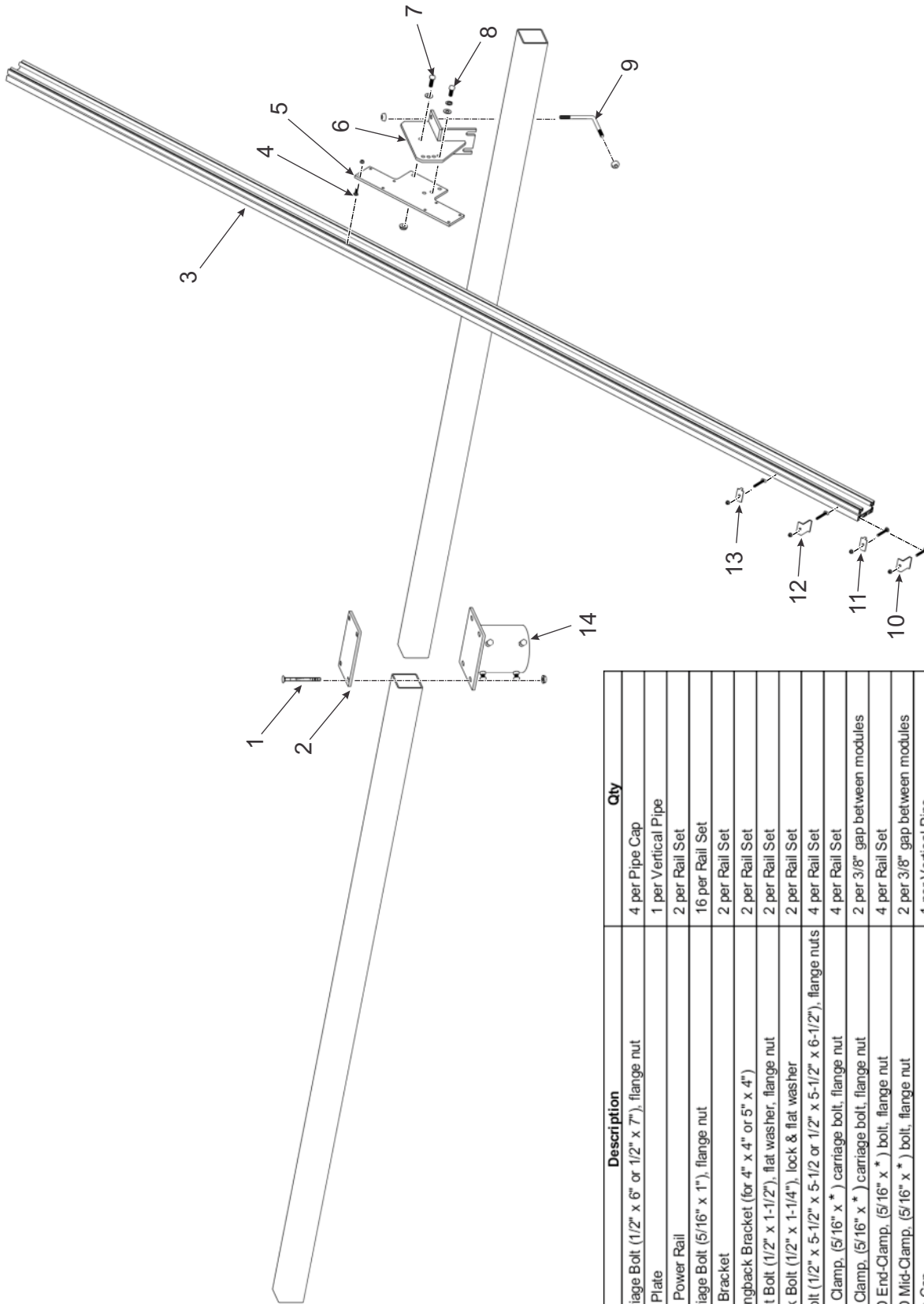

Item	Description	Qty
1	Carriage Bolt (1/2" x 6" or 1/2" x 7"), flange nut	4 per Pipe Cap
2	Top Plate	1 per Vertical Pipe
3	P14 Power Rail	2 per Rail Set
4	Carriage Bolt (5/16" x 1"), flange nut	16 per Rail Set
5	Rail Bracket	2 per Rail Set
6	Strongback Bracket (for 4" x 4" or 5" x 4")	2 per Rail Set
7	Pinot Bolt (1/2" x 1-1/2"), flat washer, flange nut	2 per Rail Set
8	Lock Bolt (1/2" x 1-1/4"), lock & flat washer	2 per Rail Set
9	L-Bolt (1/2" x 5-1/2" x 5-1/2" or 1/2" x 5-1/2" x 6-1/2"), flange nuts	4 per Rail Set
10	End Clamp, (5/16" x * ) carriage bolt, flange nut	4 per Rail Set
11	Mid Clamp, (5/16" x * ) carriage bolt, flange nut	2 per 3/8" gap between modules
12	RAD End-Clamp, (5/16" x * ) bolt, flange nut	4 per Rail Set
13	RAD Mid-Clamp, (5/16" x * ) bolt, flange nut	2 per 3/8" gap between modules
14	Pipe Cap	1 per Vertical Pipe

\* 2", 2-1/4", 2-1/2", or 2-3/4" bolt. Length is dependent on depth of PV Module frame

Notes: 1. Option to install Mid Clamp with carriage bolt or use RAD bolt with RAD Mid Clamp.  
 2. Option to install End Clamp with carriage bolt or use RAD bolt with RAD End Clamp.

### Multi-Pole Mount - G2 Parts Identification

## Step 1: Install Pipe Cap on Vertical Pipes

Before installing Pipe Caps, verify that all Vertical Pipes are level to one another.

Install one Pipe Cap on each Vertical Pipe. The Pipe Caps have three or four set bolts each to secure the Pipe Caps to the Vertical Pipe. (See Figure 1-1)

- Slip the Pipe Cap on top of the Vertical Pipe and slide it down until it rests/bottoms out on top of the Vertical Pipe.
- Rotate the Pipe Cap so that the long dimension of the flange is aligned in the E-W direction.
- For now, finger-tighten the three or four set bolts so that the Pipe Cap is free to rotate as needed for Step 2.

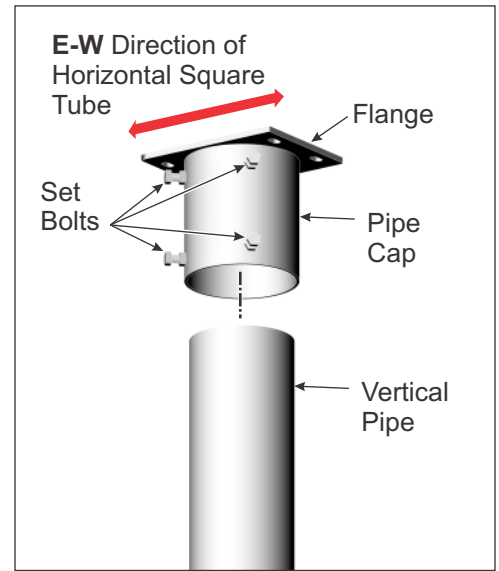

Figure 1-1: Installing Pipe Cap

## Step 2: Install the Horizontal Tube

The Horizontal tubes are secured to the Pipe Caps using a Top Plate along with four carriage bolts and flange nuts. The Tubes have been cut to length to match the spans of the previously installed vertical pipes. The ends of the Tubes are butted to each other on top of each Pipe Cap. (See Figure 2-1)

- Lift and position the Horizontal Tubes onto the Pipe Caps, creating a butt joint centered ( $\pm 1$ " ) over the Pipe Cap.
- Install the Top Plate, securing it to the Pipe Cap with four 1/2" x 6" or 7" Carriage Bolts and Flange Nuts. **Torque to 55-60 ft.-lbs.**
- Tighten the three or four set bolts on each Pipe Cap. **Torque to 32-34 ft.-lbs. for 3/8" hardware or 55-60 ft.-lbs. for 1/2" hardware.**
- Repeat for all remaining Pipe Caps.

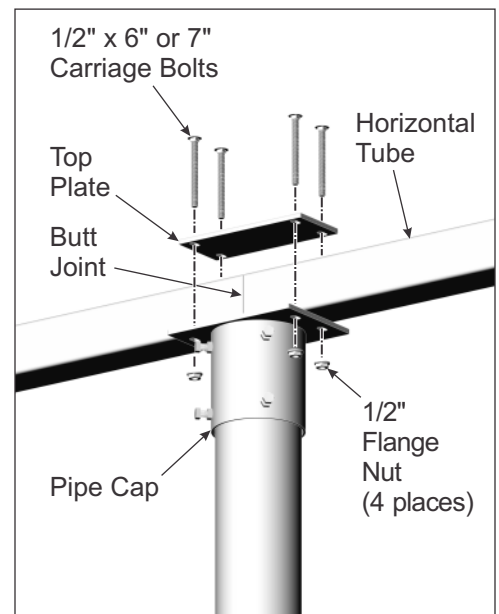

Figure 2-1: Installing Horizontal Pipe

### CAUTION:

Before assembly, be certain that the vertical pipe installation has met the project requirements and the concrete footings have fully cured.

### NOTE:

For foundation and pipe recommendations, fill out the MPM RFQ form and email to: [info@power-fab.com](mailto:info@power-fab.com)

### WARNING:

This is a two person activity. The Horizontal Square Pipes are heavy and unstable before secured. One person should hold the pipe while the other secures it to the Mounting Sleeves. Failure to do so could lead to serious personal injury.

### Step 3: Assemble the Rail Set Assemblies

#### CAUTION:

Use care while working around the structure during assembly. There could be components that create hazards or obstruct free movement causing serious bodily injury. Many are at head/eye level. Move slowly and with care around the work area.

Rail Set Assemblies include a Power Rail, Rail Bracket, and a Strongback Bracket (See Figure 3-1).

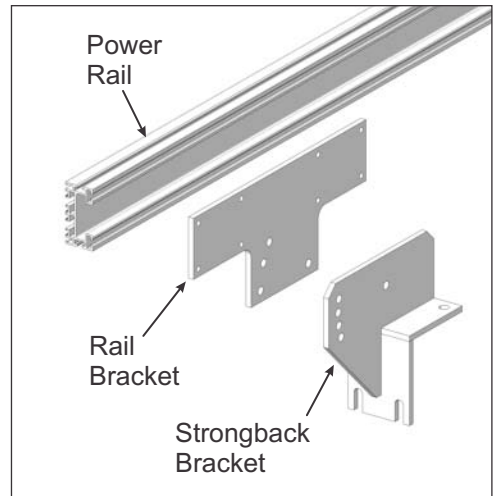

Figure 3-1: Rail Set Components

#### NOTE:

Be sure that the Rail Bracket is properly oriented to the Power Rail.

#### Attach the Rail Bracket to the Rail

The Power Rail is secured to the Rail Bracket using 5/16" x 1" carriage bolts and flange nuts. Be certain to orient the Rail Bracket to the Power Rail as shown in Figure 3-2. In particular, take note on the relationship of the Pivot Hole to the N-S directions.

- A. Along its length, measure and mark the centers of the Power Rail and the Rail Bracket. (See Figure 3-4)
- B. Pre-load eight 5/16" x 1" carriage bolts into the channels of the Power Rail (four in the upper channel and four in the lower channel). (See Figure 3-3)
- C. Mount the Rail Bracket onto the eight carriage bolts aligning the center mark on the Rail Bracket to the center mark on the Power Rail. Secure with flange nuts. **Torque to 14-16 ft-lbs.** (See Figure 3-4)

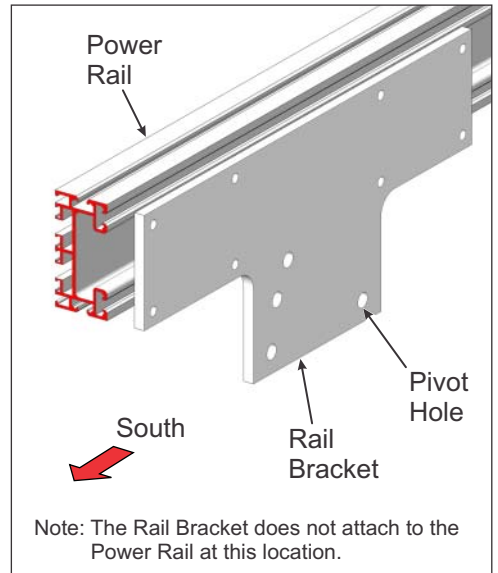

Figure 3-2: Orientation of Power Rail to Rail Bracket

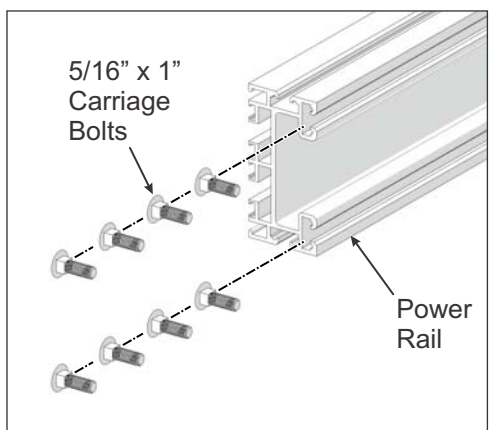

Figure 3-3: Pre-load Carriage Bolts

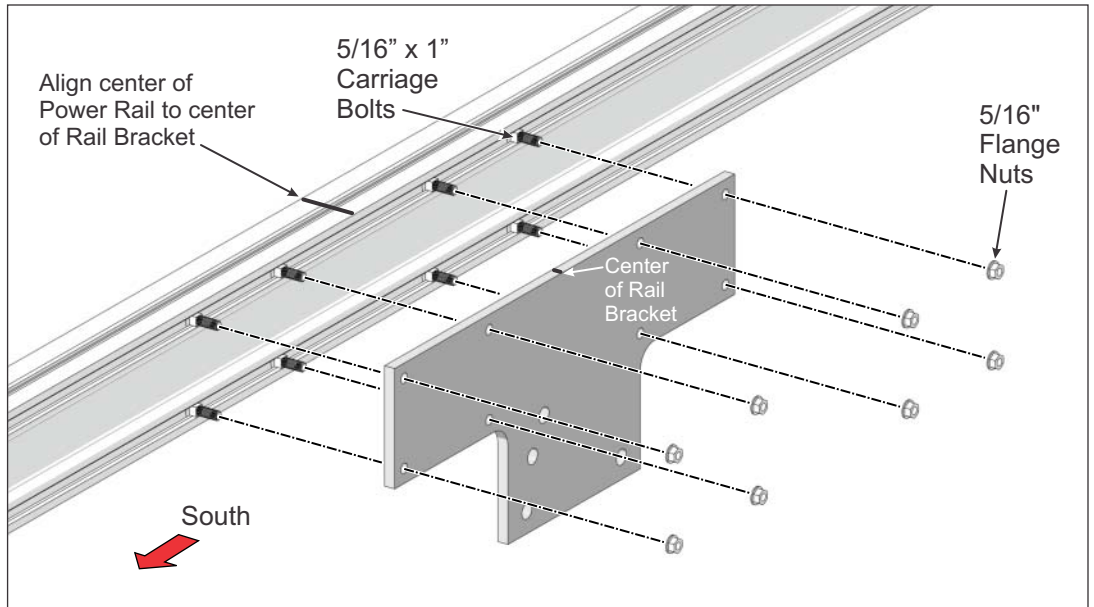

Figure 3-4 Attaching Rail Bracket to Power Rail

### Attach the Strongback Bracket to the Rail Bracket

Although the design of the Rail and Strongback Brackets allows for nine tilt angles accommodating seasonal tilt adjustments (10 through 55-degrees), for ease of assembly and safety, it's recommended to set the tilt at 0-degrees during the assembly process. After the assembly is complete, the tilt angle can be adjusted to the installation/season specific tilt.

The tilt angles are set by the use of a combination of nine different clock settings via seven holes (used to lock the tilt) and originating from the pivot bolt hole(s) of the Strongback and Rail Brackets. Figure 3-5 demonstrates this by showing the hole combination "3 & 5" which creates a 0-degree tilt.

More information on tilt angles can be found in the final section of these instructions. The Strongback Bracket is attached to the Rail Bracket using a pivot bolt and flange nut and a lock bolt and hardware.

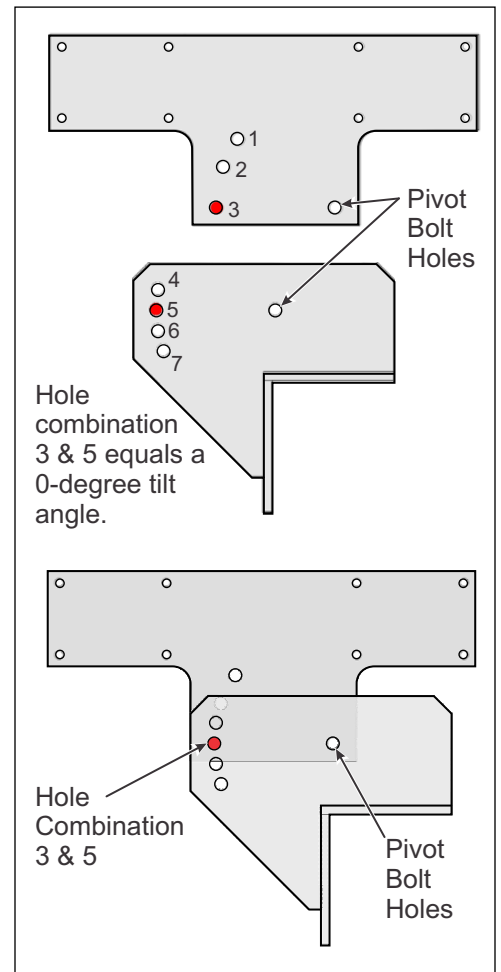

Figure 3-5: Setting a 0-degree Tilt Angle

Be certain to insert the 1/2" x 1-1/4" hex/lock bolt as shown in figure 3-4. If the hex/lock bolt is inserted from the opposite side, it will not secure the Rail Bracket to the Strongback Bracket creating an unstable rack.

**WARNING:**

The Rail Bracket must be secured to the Strongback Bracket using the hex/lock bolt as shown in figure 3-4. Failure to do so could lead to structural failure and or personal injury.

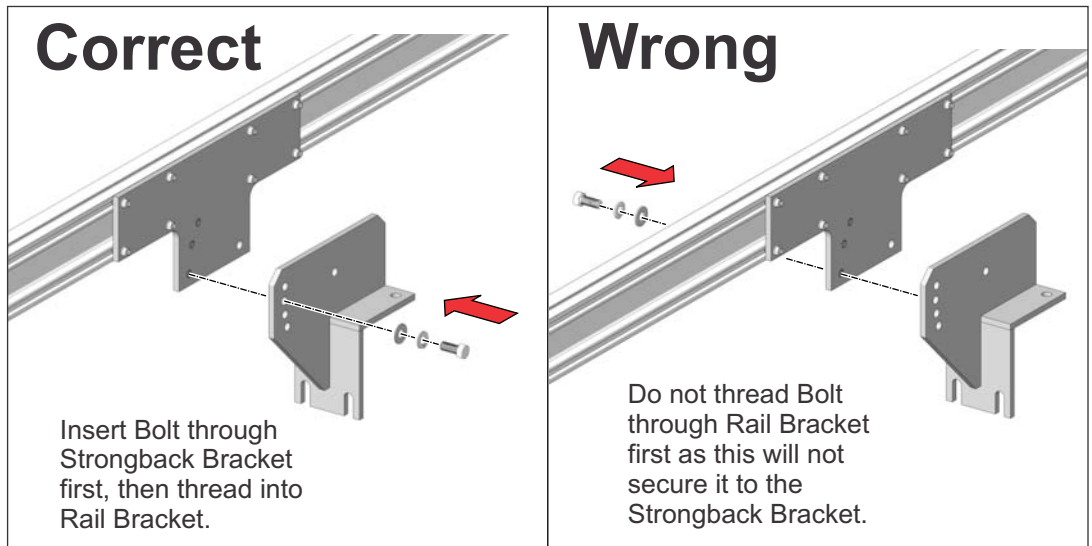

Figure 3-4 Correct and Wrong methods of installing hex/lock bolt

- A. Align the pivot bolt holes and insert the 1/2" x 1-1/2" pivot bolt with flat washer, securing with a 1/2" flange nut. Finger tighten only for now. (See Figure 3-5)
- B. Rotate the Strongback Bracket to align the 3 & 5 hole combination. Referring to figures 3-4 and 3-5, insert the 1/2" x 1-1/4" hex/lock bolt with flat and lock washers and tighten securely. **Torque to 45-50 ft-lbs.**
- C. Return and tighten the pivot bolt. **Torque to 45-50 ft-lbs.**

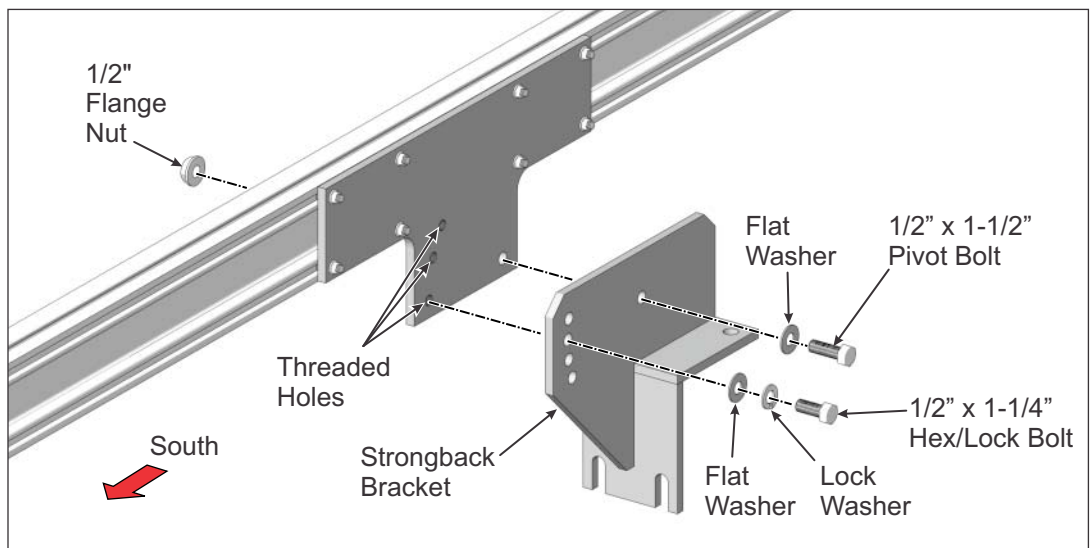

Figure 3-5 Attaching Strongback Bracket to Rail Bracket (0-degree Tilt Angle)

## Step 4: Attaching the Rail Set Assemblies to the Horizontal Tube

Each Rail Set Assembly is secured to the Horizontal Tube using two 1/2" L-Bolts and four Flange Nuts per Rail Set.

Rail Set Assemblies are spaced along the Horizontal Tube in predetermined spans. The span between each is dependent on the size of Modules to be used. Follow the instructions below to measure and mark the locations of the Rail Set Assemblies on the Horizontal Tube. If a Rail Set Assembly lands on or near a Pipe Cap and prevents the Pipe Cap from being properly secured to the Horizontal Tube, the Assembly must be shifted to work around the Pipe Cap. This procedure is also explained below.

It is best to start from the center of the Multi-Pole Mount-G2 system and work outward. This will ensure a centered array over the system.

- A. Start by measuring and marking the center of the entire run of Horizontal Tube.
- B. Determine if there are an odd or even number of modules per row. Refer to the title block of the Layout Drawings for this number. (See Figure 4-1)

Total Modules	Sets of Modules	Number of Rows
		
DIRECT POWER AND WATER 4000 VASSAR DRIVE NE ALBUQUERQUE, NEW MEXICO 87107		
TITLE: DP-MPM124-YNG230-31x4		
CUSTOMER: PRO-TECH ENERGY	DRAWN BY: A.G.	DATE: 7-29-10
PROJECT: PEDDIE SCHOOL SUB ARRAY 9	ENGINEER: J.R.	SHT. 2
THIS DRAWING IS THE PROPERTY OF DPW SOLAR, AND CANNOT BE USED, COPIED, OR DISCLOSED WITHOUT PERMISSION. DO NOT SCALE DRAWING		

In this example there are:  
31 Sets of  
4 Modules in  
Landscape

Figure 4-1: Sample Title Block from DPW Layout Drawing - Use to determine number of Modules Per Row

- C. Measure and mark the locations of the Rail Sets along the Horizontal Tube as shown in the either Figure 4-2 for odd numbers or Figure 4-3 for even numbers of modules.

As a rule-of-thumb, Rail Sets are centered under each Module with a span between Rail Set Assemblies equal to 60% of the Module length. Once these are measured and marked, the next-in-line Rail Set Assembly is measured and marked using a factor equal to 20% of the Module Length plus 1/2" (the 1/2" is the spacing between Modules). Calculate the 20% factor, double it and add 1/2", the end result is the span (center to center) for the next-in-line Rail Set Assembly.



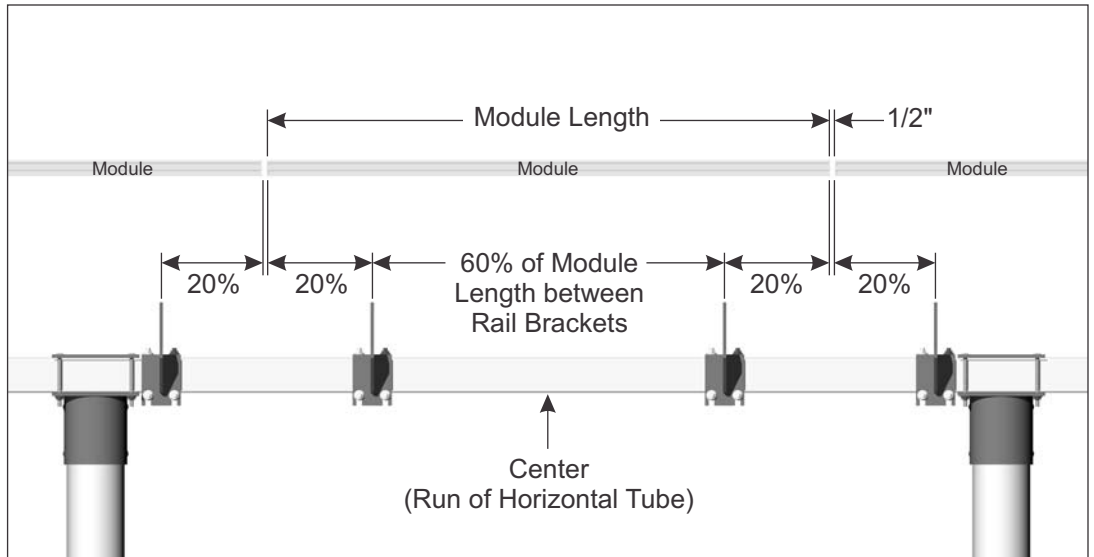

Figure 4-2: Establishing Position and Spacing of Rail Set Assemblies - for an install with an **Odd number of Rail Sets**

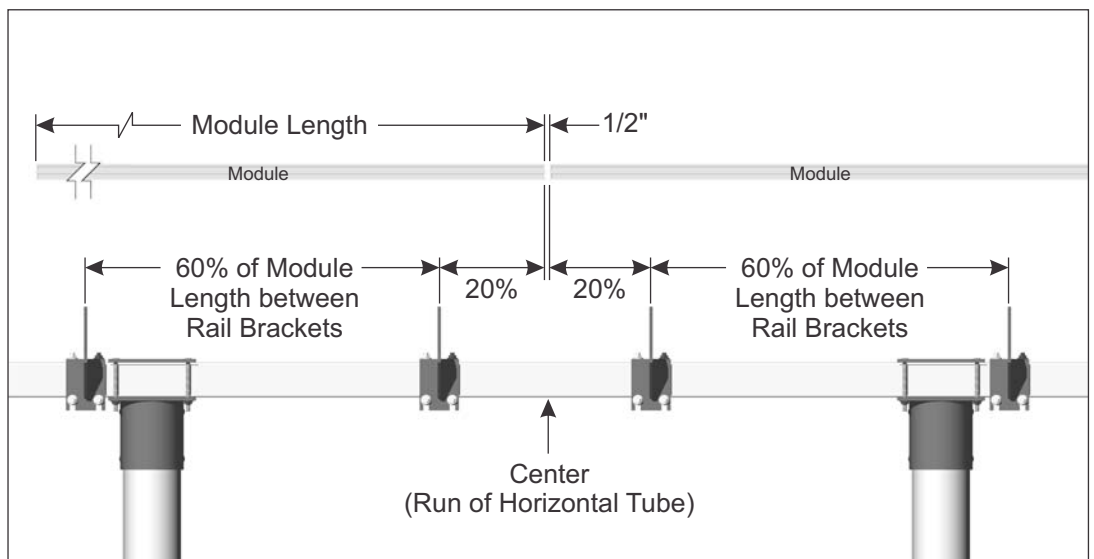

Figure 4-3: Establishing Position and Spacing of Rail Set Assemblies - for an install with an **Even number of Rail Sets**

### How to work around the Pipe Caps

There will likely be situations where the placement of the Rail Set Assembly (using the guidelines above) is such that the assembly lands too close to or on top of a Pipe Cap/Top Plate in such a manner as to prevent the assembly from being properly installed. If this occurs, the Rail Set Assembly must be repositioned in order to avoid the Pipe Cap and allow proper attachment of the assembly to the Horizontal Pipe. If repositioning is required, it must be done in such a way that the Rail Set Assembly is repositioned as close as is possible to the Pipe Cap while still allowing for proper attachment to the Horizontal Tube. (See Figure 4-4)

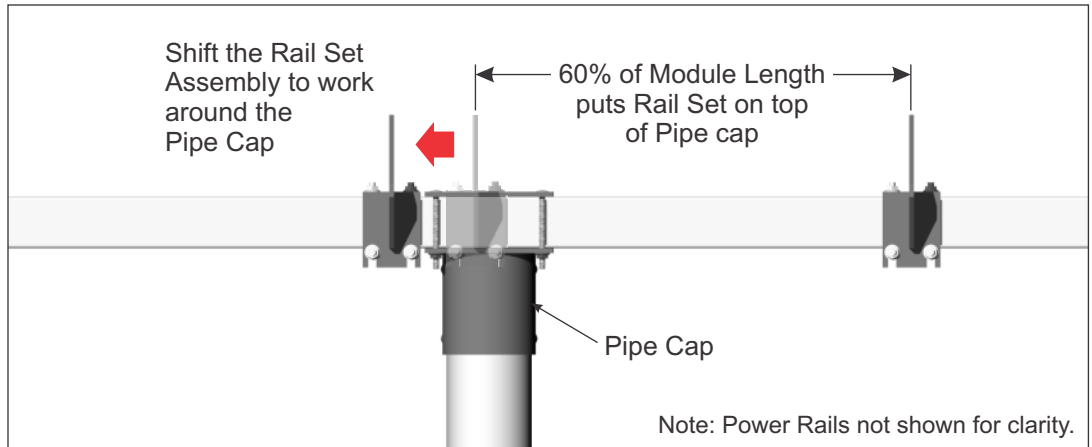

Figure 4-4: Repositioning a Rail Set to work around a Pipe Cap

### Attaching the Rail Sets to the Horizontal Tube

**WARNING:**

This is a two person activity, because the Rail Set is unstable before it's secured. One person should steady the Rail Set while the other secures it. Failure to do so could lead to serious personal injury.

- A. Using a tape measure, mark the pre-determined locations of the Rail Sets on the Horizontal Tube using the instructions outlined above. (See Figure 4-5)
  - B. Place the Rail Set on top of the Horizontal Tube, aligning it to its mark made in Step A above.
  - C. From below, insert the two 1/2" L-Bolts into the two holes of the Rail Bracket guiding the opposite ends into the two notches on the opposite side of the Rail Bracket. Loosely thread two 1/2" Flange Nuts on each of the L-Bolts.
  - D. Continue to tighten the Flange Nuts, alternating between the four so the L-Bolts and Rail Bracket are drawn evenly against the Horizontal Pipe. (See Figure 4-6)
- Torque all four to 45-50 ft.-lbs.**

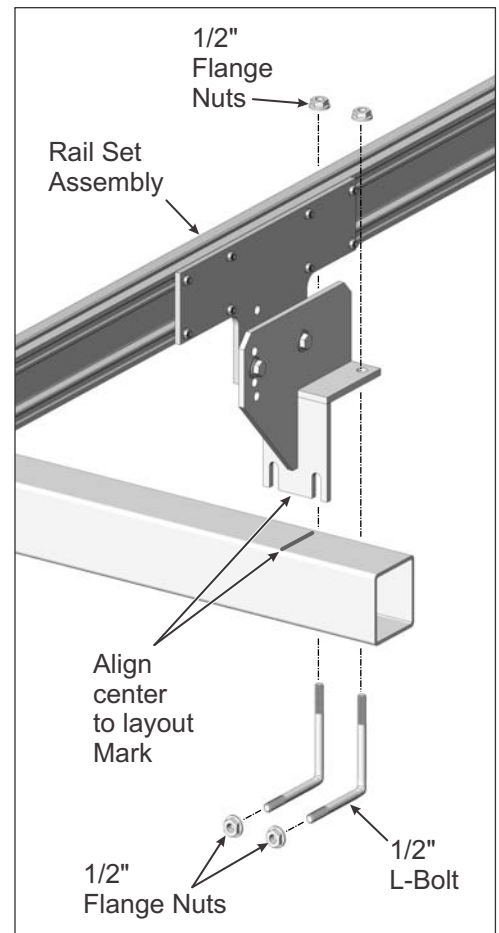

Figure 4-5: Attaching the Rail Set to the Horizontal Tube

**CAUTION:**  
Be sure to tighten the L-Bolts evenly to close any gaps and keep the Rail Bracket tight against the Horizontal Pipe.

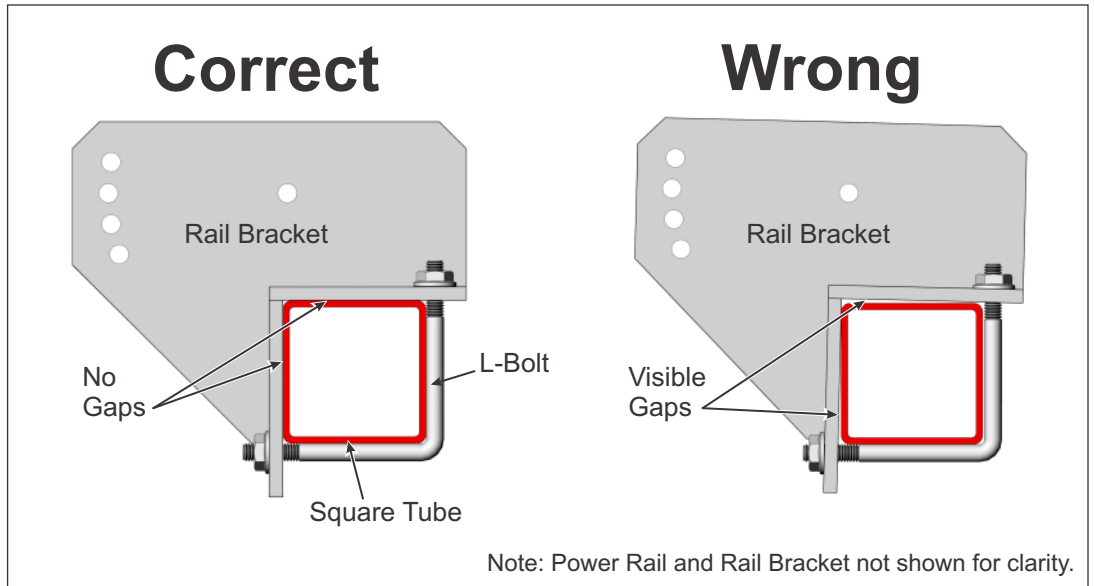

Figure 4-6: Alternate Tightening of L-Bolts to Close Gaps

### Step 5: Installing PV Modules to Power Rails with Module Clamps

**WARNING:**  
This is a two person activity. Modules are heavy. One person should hold and align the modules while a second person secures the Modules with clamping hardware. Failure to do so could lead to serious personal injury and/or damaged components.

PV Modules are secured to the Power Rail using Mid and End Clamps (Standard or RAD), along with the appropriate attaching hardware. Attaching hardware includes Carriage Bolts or RAD Bolts for Mid Clamps and End Clamps.

#### The importance of correctly installing End and Mid Clamps:

There is only one correct method of installing End Clamps and Mid Clamps. Failure to follow the correct method could lead to personal injury, structural failure, and/or damaged components. See Figure 5-1 for proper method of installation for an End Clamp and Figure 5-2 for the Mid Clamp. Refer to these figures during the installation of the Modules to prevent any undue problems associated with an improper installation.

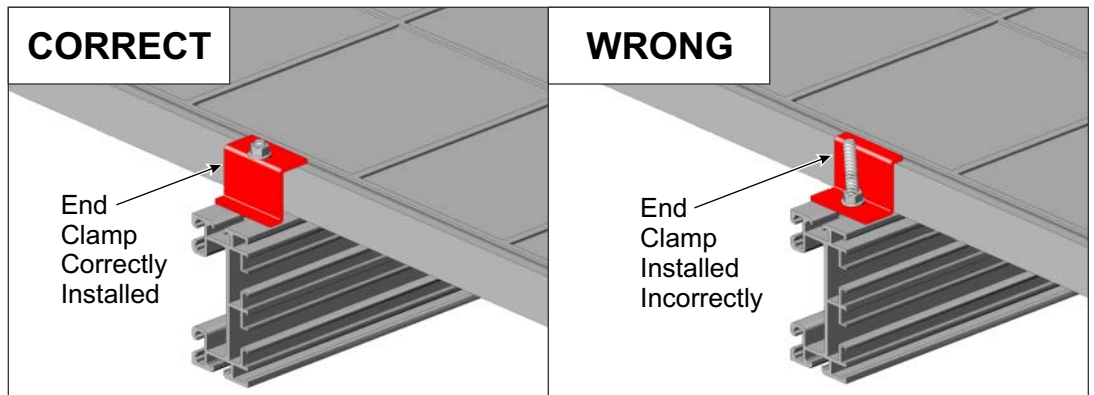

Figure 5-1: Correct and Wrong methods of installing an End Clamp

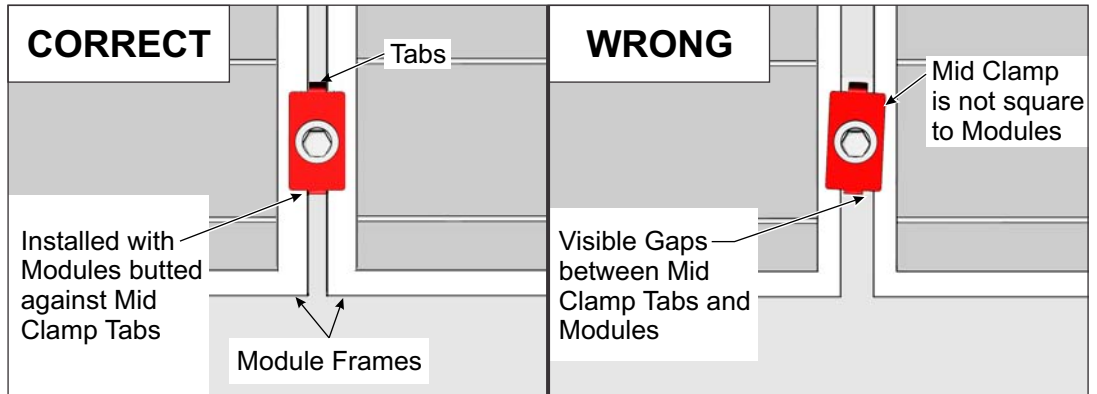

Figure 5-2: Correct and Wrong methods of installing a Mid Clamp

### Installing Modules using Standard End and Mid Clamps:

Start with exterior Module and End Clamps.

- A. Place Module on two Power Rails, centering it lengthwise. Use a square to square-up the Module to the Power Rails.
- B. Insert one 5/16" x 2, 2-1/4, 2-1/2 or 2-3/4" carriage bolt into the top slot of the Power Rail. Push the bolt against the side of the module frame. Install End Clamp onto bolt and secure with 5/16" flange nut. **Torque to 14-16 ft.-lbs.** (See Figures 5-1 and 5-3)

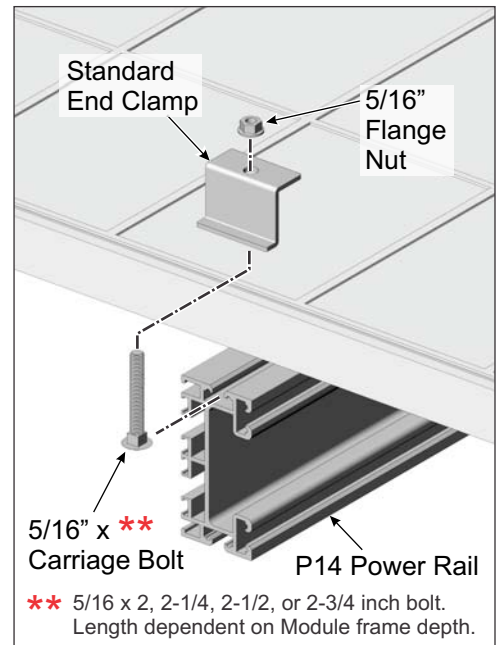

Figure 5-3: Installing Modules using Standard Hardware End-Clamp

Now install the next in-line Module using Mid Clamps.

- C. Before placing the interior Module onto the Power Rails, first insert two (one in each Power Rail channel) 5/16" x 2, 2-1/4, 2-1/2, or 2-3/4" carriage bolts (bolt length is dependent on depth of Module frame) into the Module Rail, sliding the bolts inward next to the previously installed exterior Module. (See Figure 5-4)

**NOTE:**

If using standard 5/16" carriage bolts for Mid Clamps, the bolts must be inserted into the Power Rail before installing next in-line northern Modules.

If using RAD hardware, the hardware can be inserted anytime at any position along the Power Rail.

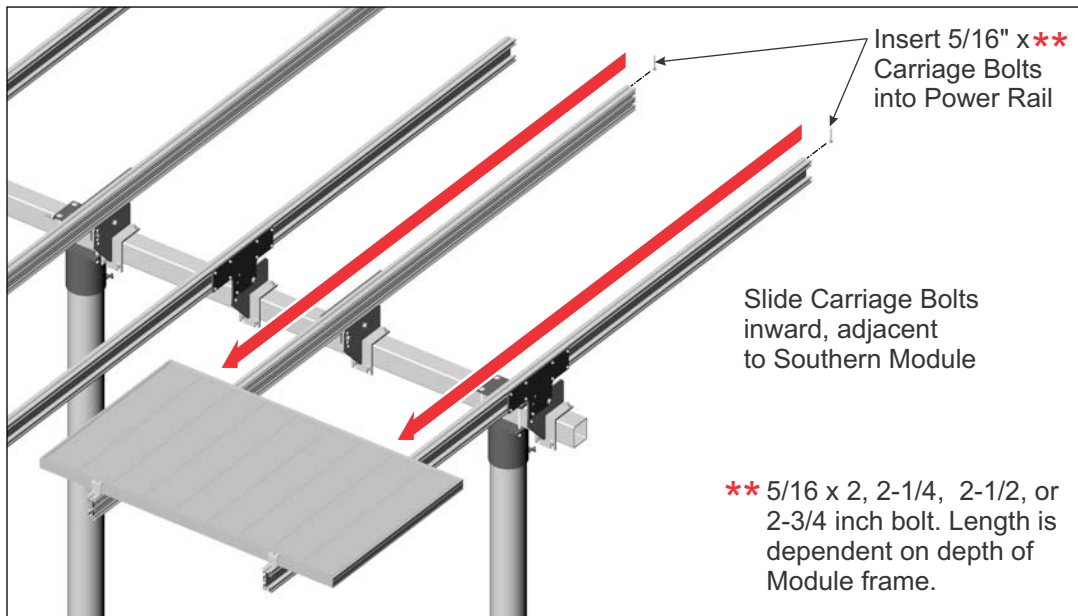

Figure 5-4: Pre-loading Standard Mid Clamp Hardware into Power Rail

**WARNING:**

The Tabs of the Mid Clamps must rest between the Modules. Failure to do so could lead to serious personal injury and/or damaged components and property.

- D. Install a Mid Clamp onto each carriage bolt making certain that the Mid Clamp tabs rest between the two modules.
- E. Push Modules against Mid Clamp tabs and secure Mid Clamp with 5/16" flange nut. **Torque to 14-16 ft.-lbs.** (See Figures 5-2 and 5-5)

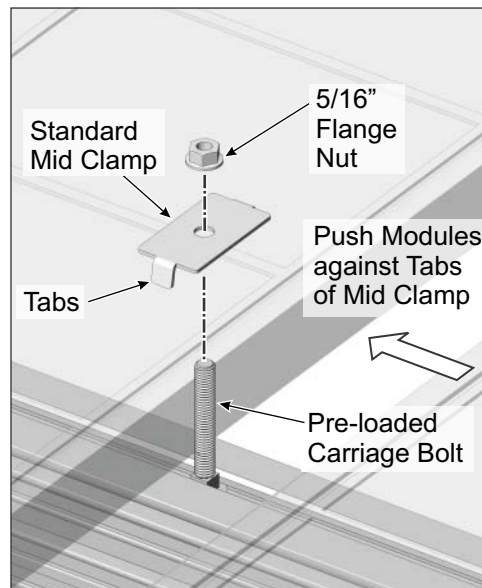

Figure 5-5: Installing Modules using Standard Hardware Mid Clamp

## Installing Modules using RAD End and Mid Clamps:

Start with exterior Module and End Clamps.

### WARNING:

Be certain that all Flange Nuts on End and Mid Clamps are tightened and torqued to the stated values. Failure to do so could lead to serious personal injury and/or damaged components and property.

### NOTE:

RAD Bolts must be locked into the channel by rotating clockwise 90-degrees. Use the indicator slot on the threaded end to identify whether or not the bolt has been locked.

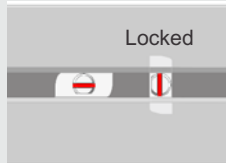

Indicator Slot shown in **Red**

### WARNING:

The Tabs of the Mid Clamps must rest between the Modules. Failure to do so could lead to serious personal injury and/or damaged components and property.

- A. Place Module on two Power Rails, centering it lengthwise. Use a square to square-up the Module to the Power Rails.
- B. Insert one 5/16" x 2, 2-1/4, 2-1/2 or 2-3/4" RAD bolt into the top slot of the Power Rail. Push the bolt against the side of the module frame and twist to lock in place. Install End Clamp onto bolt and secure with 5/16" flange nut. **Torque to 14-16 ft.-lbs.** (See Figures 5-1 and 5-6)

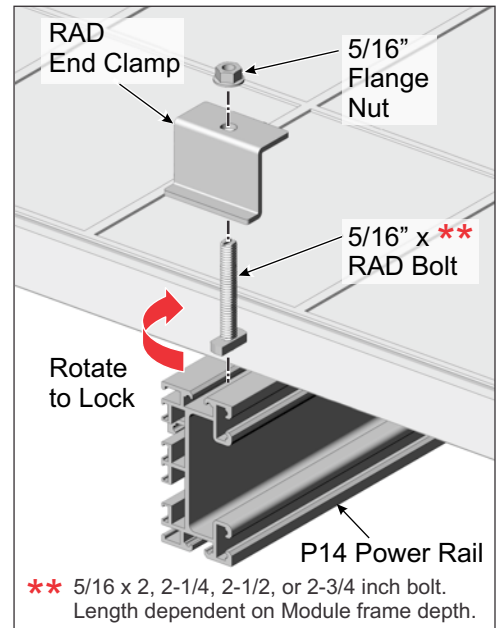

Figure 5-6: Installing Modules using RAD Hardware End Clamp

Install next in-line Module using Mid Clamps.

- C. Insert one 5/16" x 2, 2-1/4, 2-1/2, or 2-3/4" RAD bolt (bolt length is dependent on depth of Module frame) into each Rail, next to the previously installed exterior Module. Twist RAD bolt to lock in place. (See Figure 4-7)
- D. Place next Module onto Rails.
- E. Install a Mid Clamp onto each RAD bolt making certain that the Mid Clamp tabs rest between the two modules.
- F. Push Modules against Mid Clamp tabs and secure Mid Clamp with 5/16" flange nut. **Torque to 14-16 ft.-lbs.** (See Figures 5-2 and 5-7)

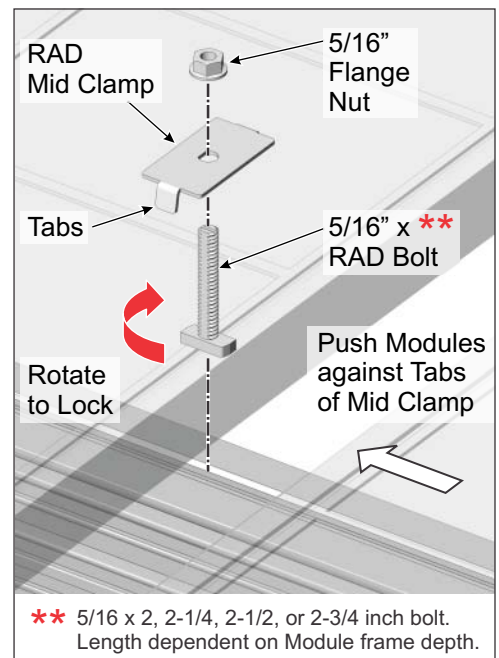

Figure 5-7: Installing Modules using RAD Hardware Mid Clamp

## Step 6: Change the Tilt Angle of the Array

### WARNING:

Do not attempt to remove the Pivot Bolt during tilt adjustments! Removal could lead to serious personal injury or death. Adjustments are made with the Pivot Bolt hardware loosened but in place.

### CAUTION:

This is a two person activity. As the Pivot Bolt is loosened and the Support Bar hardware is removed, the rack is heavy and unstable. The rack must be held in place by one person while the second person loosens and removes the hardware and then re-installs/tightens the hardware back in place. Failure to do so could lead to serious personal injury and damaged components.

This procedure can be dangerous if it is not completed as described with a minimum of two people so use great care. The process involves loosening the pivot bolt and the temporary removal of the lock bolt. When the lock bolt is removed; the rack becomes unstable and must be held in place by a second person.

As discussed in Step 3, the tilt angle is set by a specific hole combination which is unique to the desired tilt angle. The hole combination is derived by a series of three threaded holes in the Rail Bracket and four holes in the Strongback Bracket (see Figure 6-1). For example, if a 40-degree tilt is desired, the hole combination would be 2 & 7. The table in Figure 6-1 defines the nine possible tilt angles and their respective hole combinations.

A. While one person holds the south edge of rack, the other loosens the Pivot

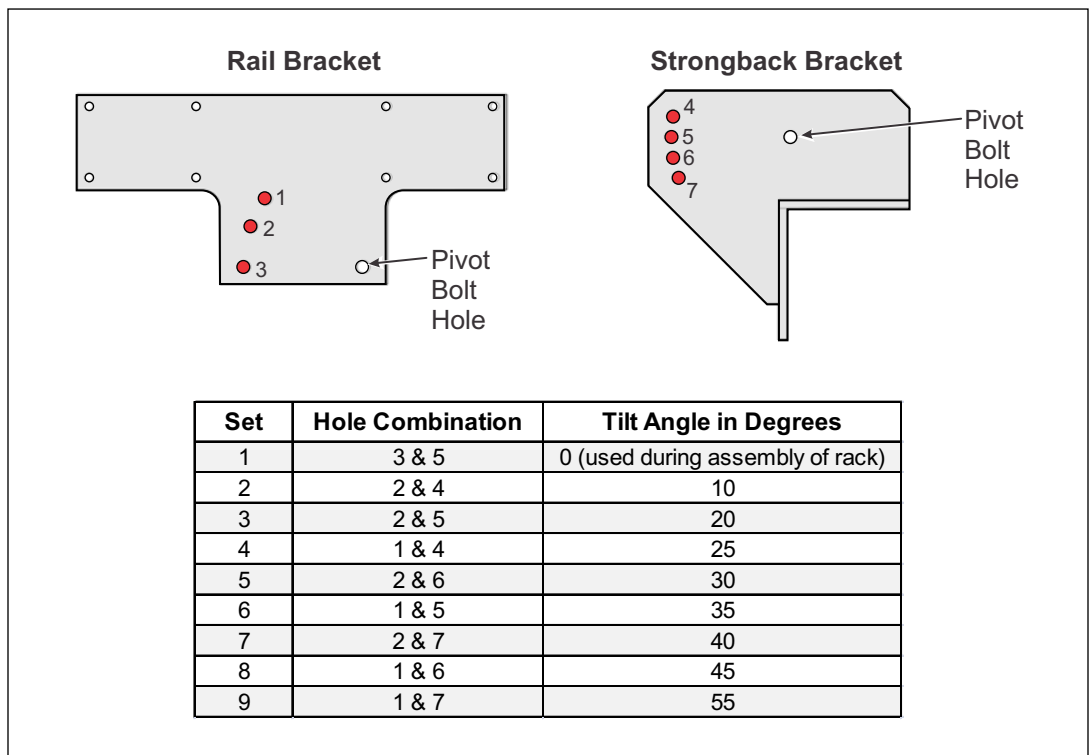

Figure 6-1: Determining Hole Combinations for Specific Tilt Angles

Bolt and removes the 1/2" lock bolt and hardware from the Strongback Bracket. (See Figure 6-2)

- B. Tilt the rack to the appropriate hole combination matching the desired tilt and re-install the 1/2" lock bolt and hardware, passing it through the Strongback Bracket and into the threaded hole of the Rail Bracket. **Torque to 45-50 ft.-lbs.**
- C. Re-tighten the Pivot Bolt as the Pivot Bolt cannot be left loose. The Rail Bracket and Strongback Bracket must be firmly clamped to one another eliminating any gaps between them. **Torque to 45-50 ft.-lbs.**

**WARNING:**  
Do not attempt to remove the Pivot Bolt during tilt adjustments! Removal could lead to serious personal injury or death. Adjustments are made with the Pivot Bolt hardware loosened but in place.

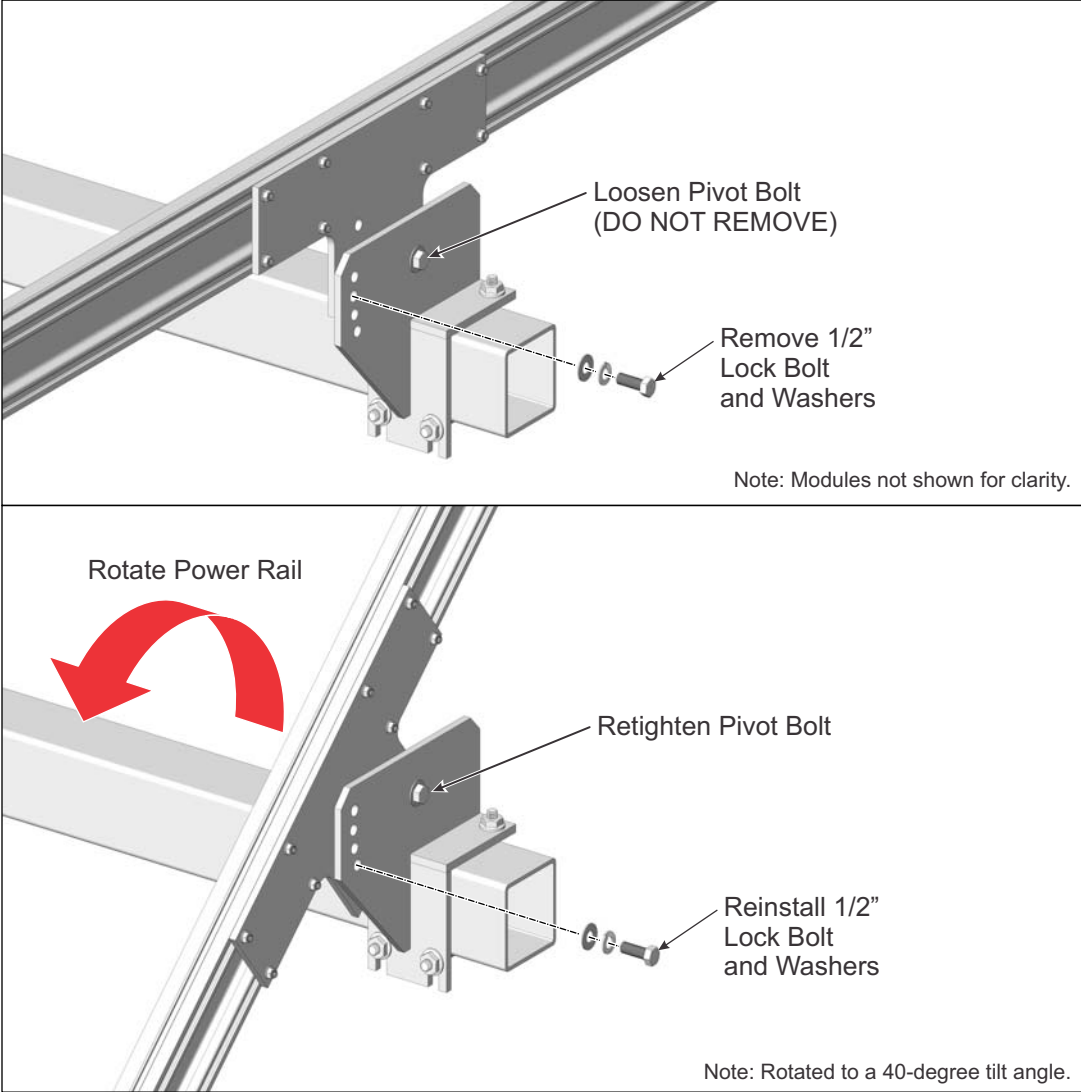

Figure 6-2: Changing the Tilt Angle





2716 Vassar Place NE  
Albuquerque, New Mexico 87107  
USA

Telephone: 800.260.3792  
Fax: 505.889.3548  
Web Site: [www.DPWSolar.com](http://www.DPWSolar.com)  
E-mail: [info@dpwsolar.com](mailto:info@dpwsolar.com)

© 2012 Preformed Line Products  
PCN 042412-1  
Version 1, Rev D  
SP3287

Preformed Line Products  
(Canada) Limited  
1711 Bishop St. E  
Cambridge, ON N1T 1N5

Telephone: 519.740.6666  
Fax: 519.740.7917  
Web Site: [www.preformed.on.ca](http://www.preformed.on.ca)  
E-mail: [sales@preformed.on.ca](mailto:sales@preformed.on.ca)