

MNSMARB-KIT INSTALL INSTRUCTIONS REVA 8-12-15

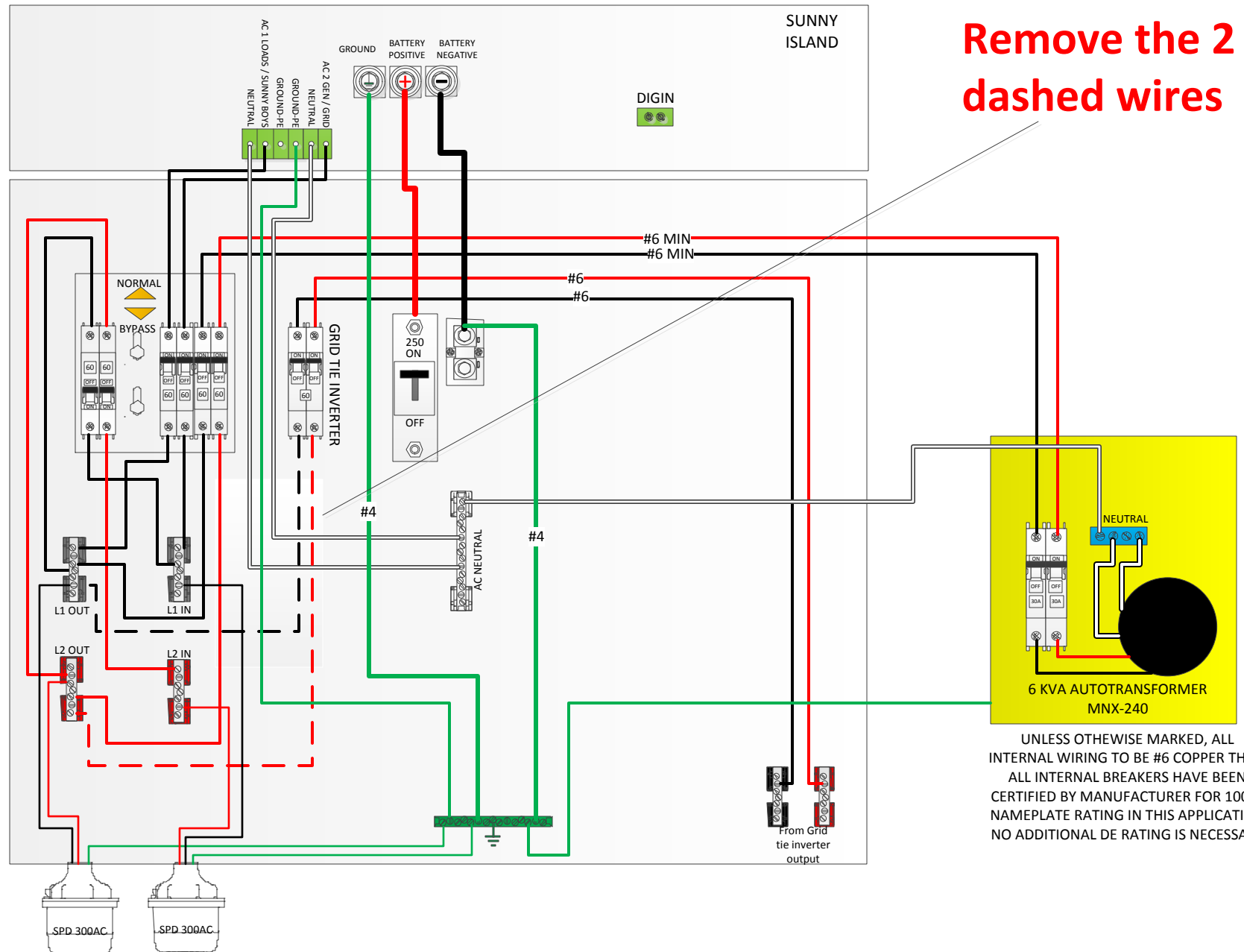

SMA Single AC Coupled repair procedure REVC 3/20/2014

Install the SMARB in chassis using included hardware. Then install the 4 (Not supplied) wires as shown (# 6 AWG)

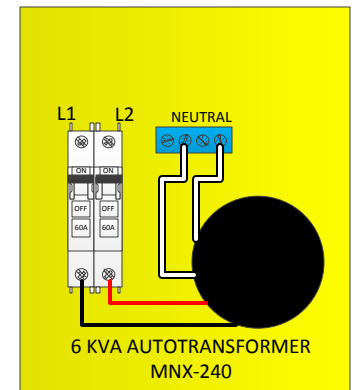
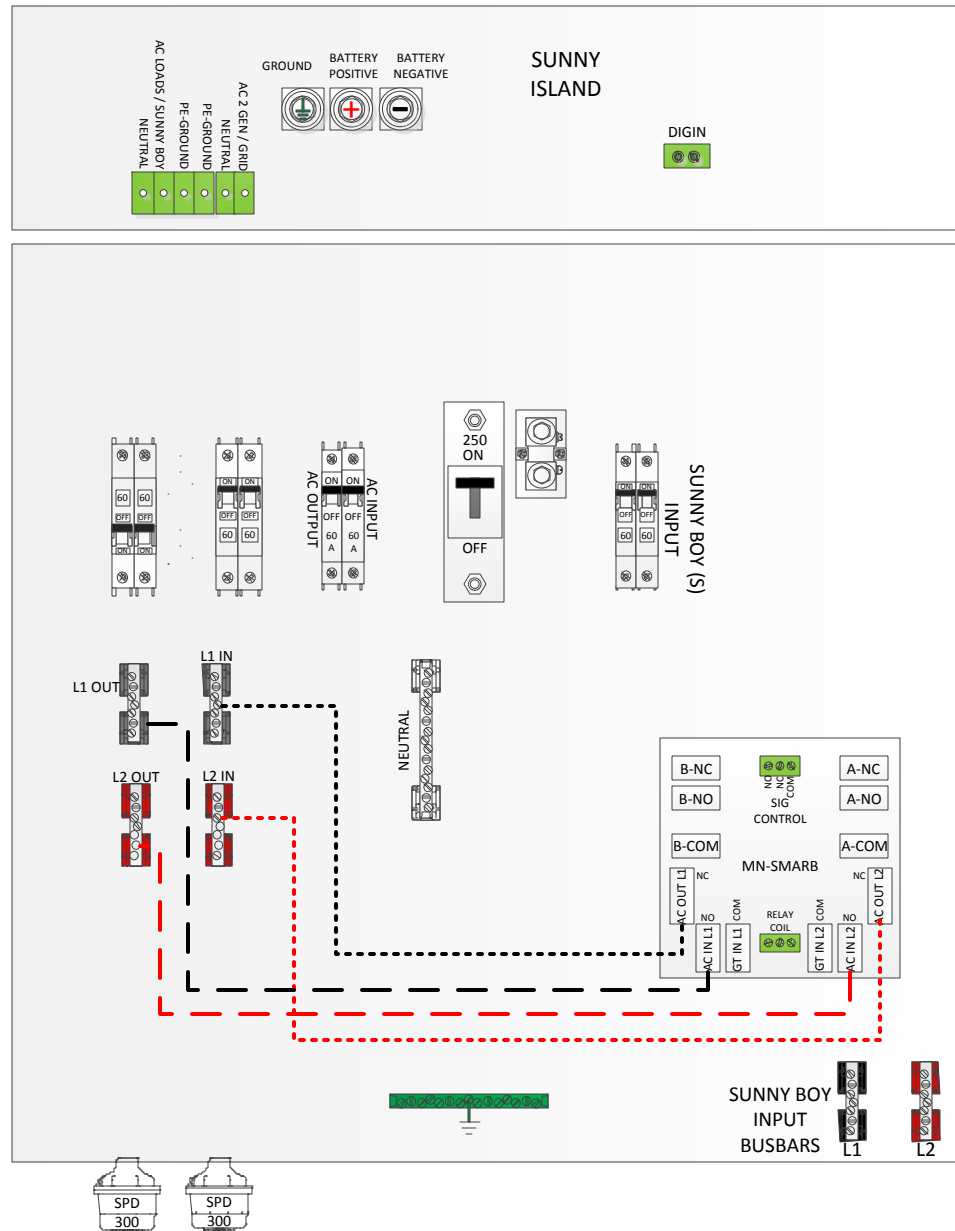

MNSMARB-KIT INSTALL INSTRUCTIONS REVA 8-12-15

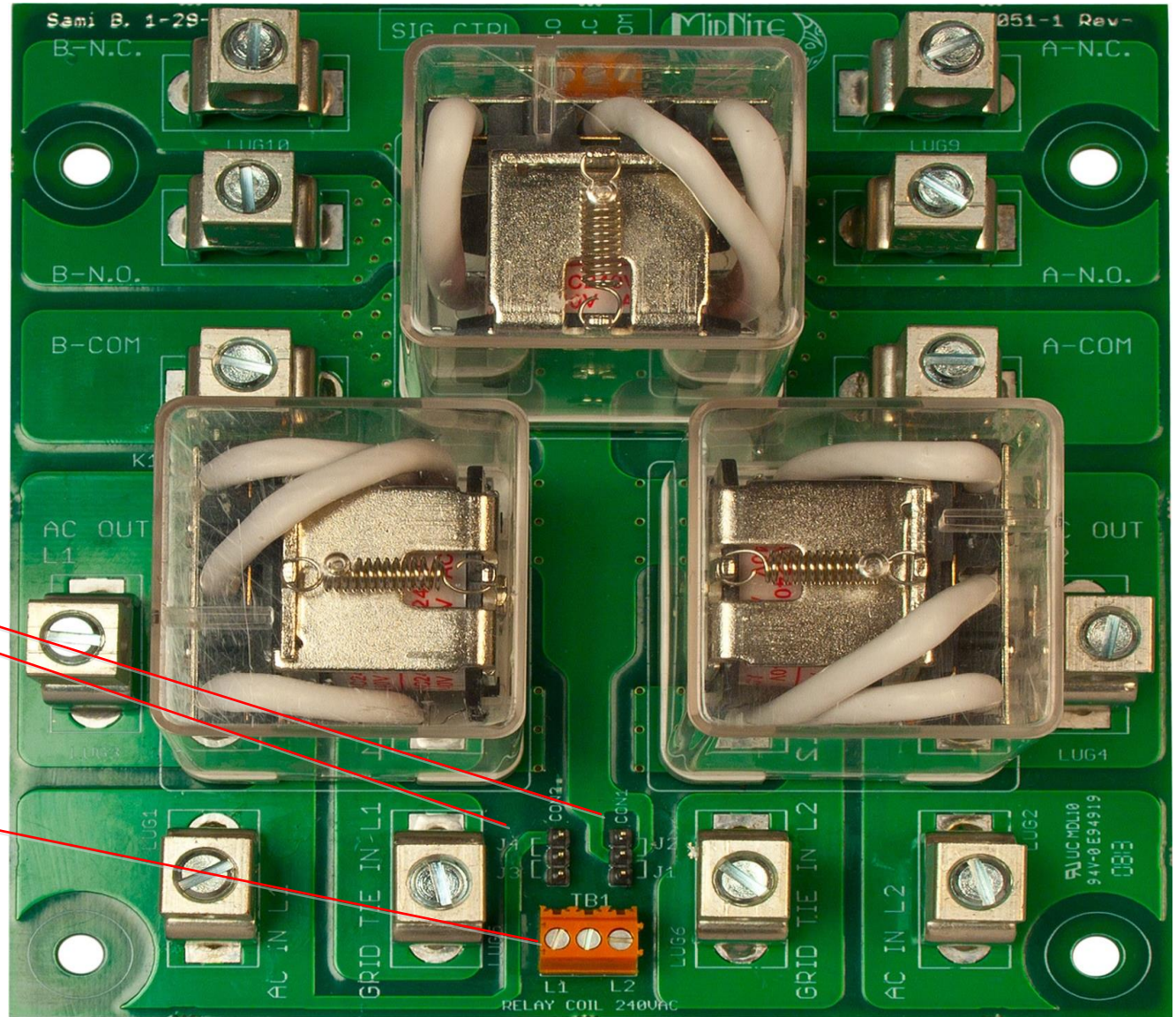

- 1- Verify the jumpers are installed on J1 and J3
- 2- Take note of the Relay Coil terminal block we will be wiring to it on a future page

MNSMARB-KIT INSTALL INSTRUCTIONS REVA 8-12-15

- 1- Install the 2 included 15 amp 2 pole black ac breakers
- 2- Install the red and black #14 wire as shown
- 3- Install delay timer relay as shown

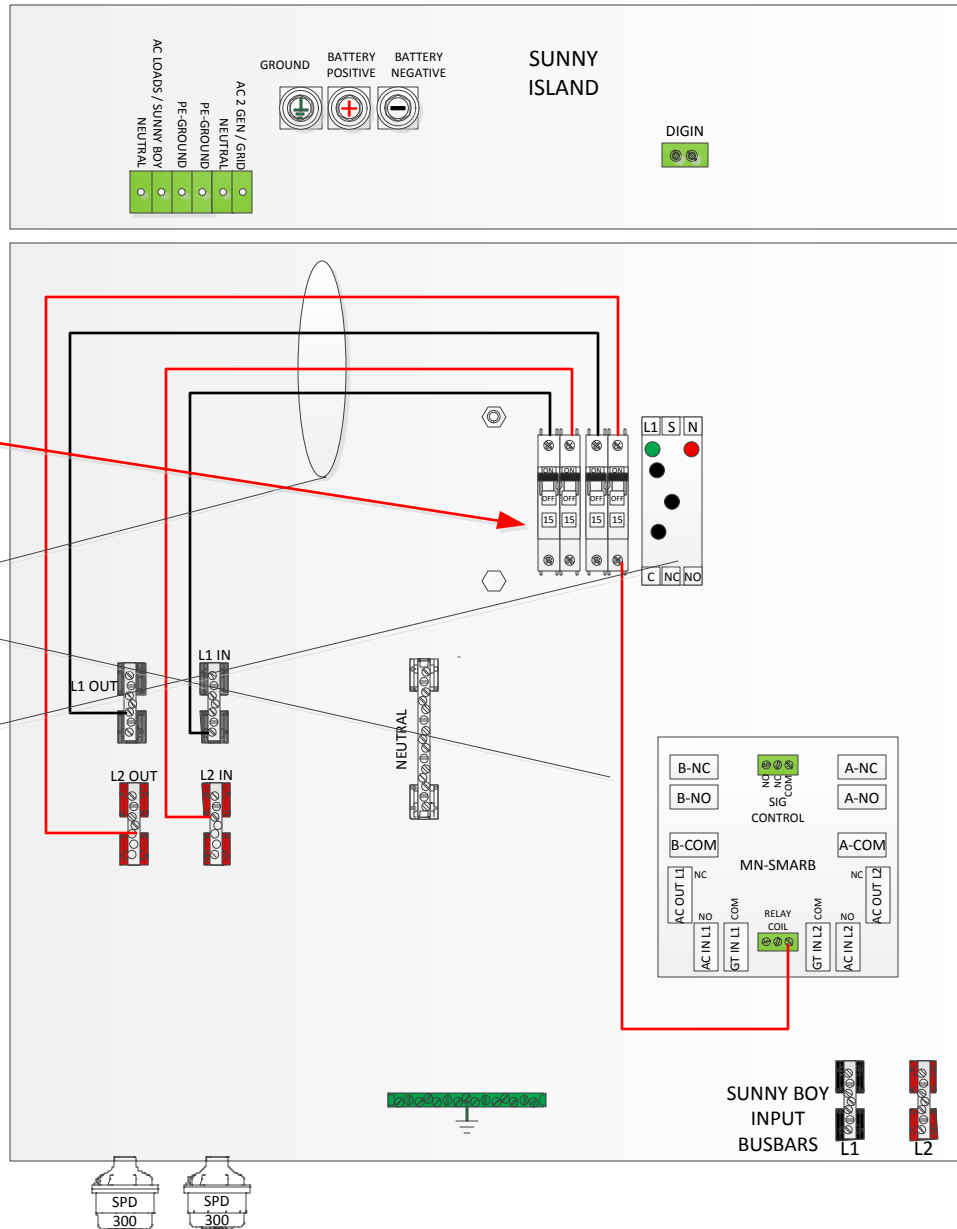

MNSMARB-KIT INSTALL INSTRUCTIONS REVA 8-12-15

Relay kit should follow this wiring scheme when installed. The 2 relays can be Zip tied to the breaker bracket under the 2 15 amp breakers

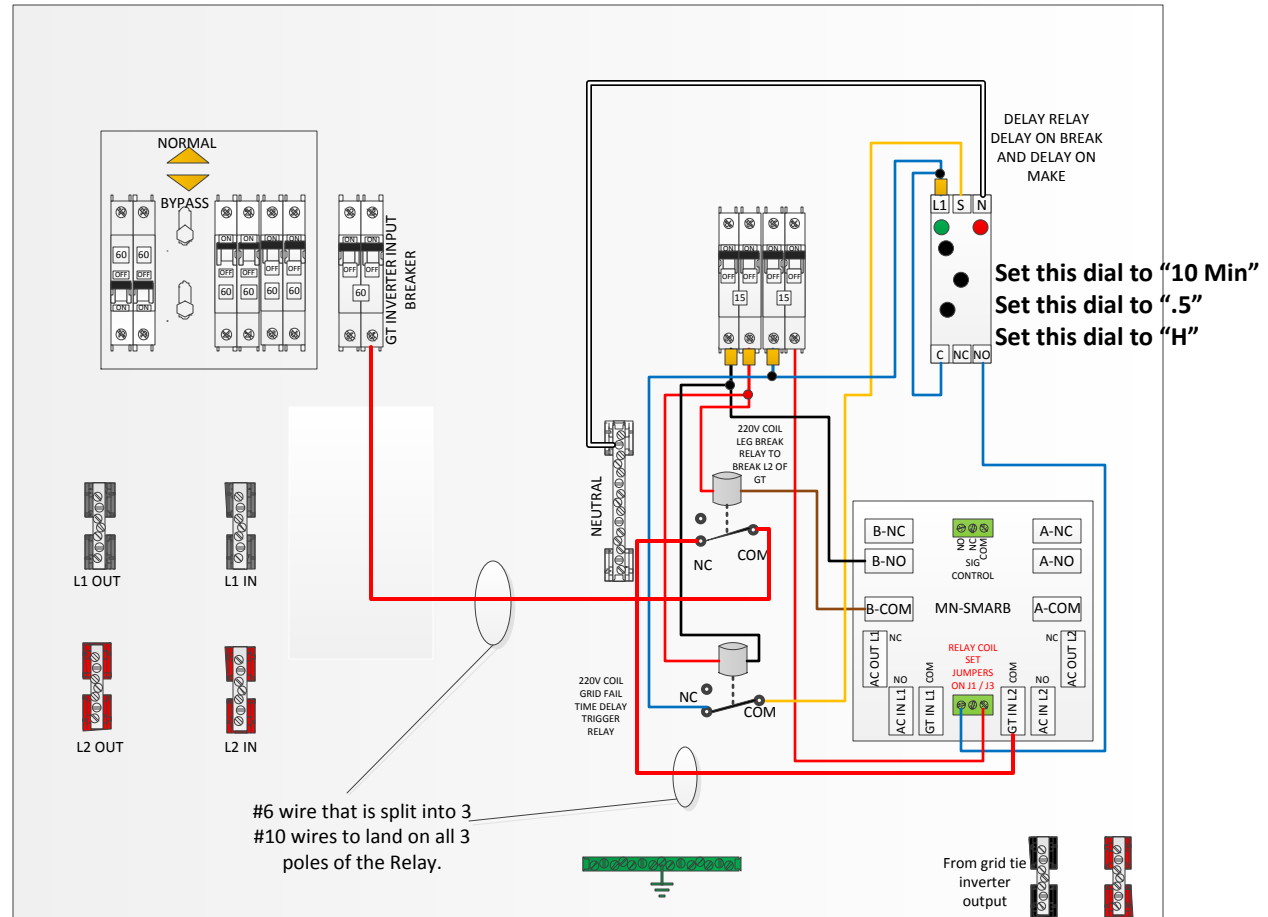

MNSMARB-KIT INSTALL INSTRUCTIONS REVA 8-12-15

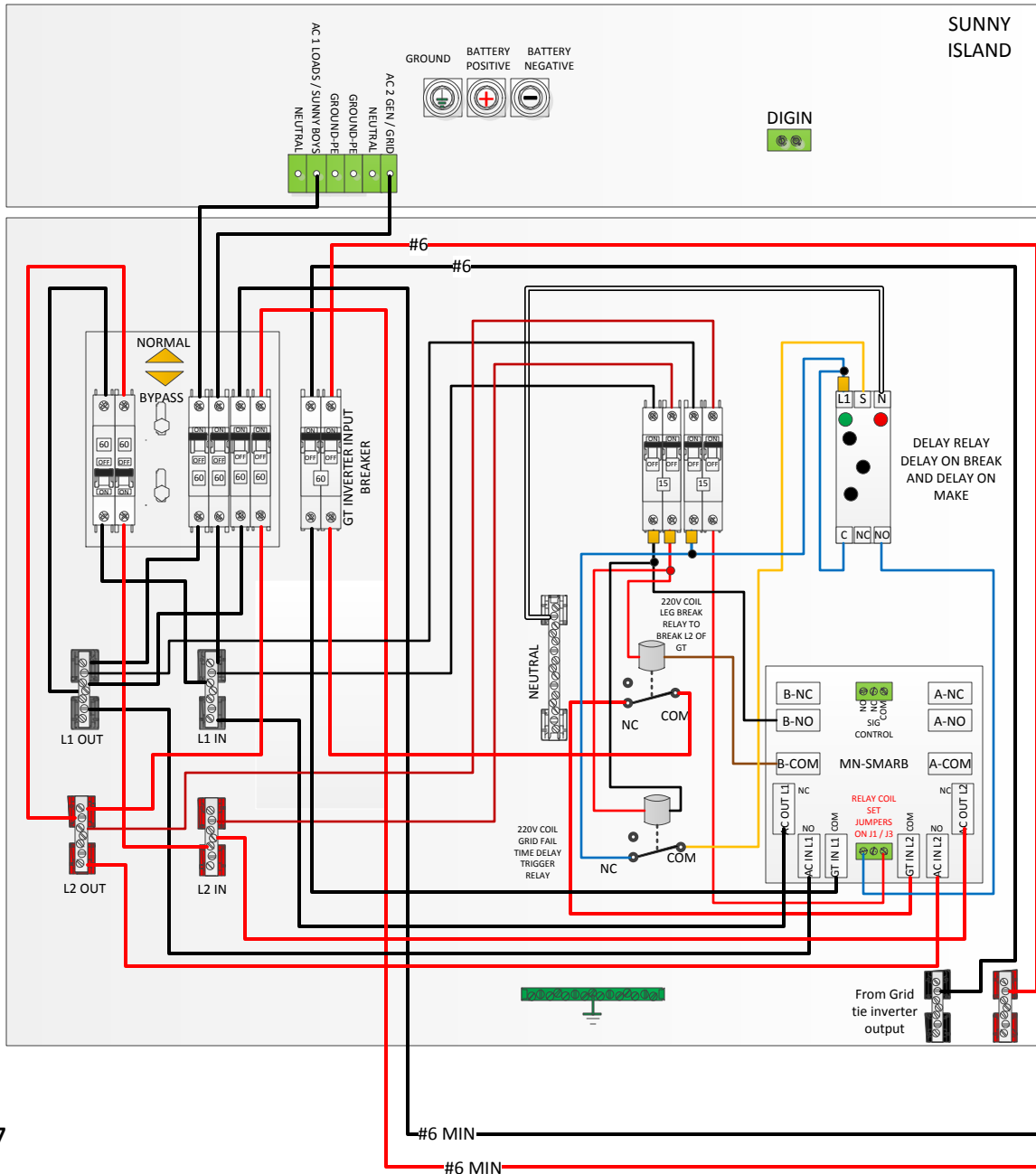

IN THIS CONFIGURATION, THE AUTOFORMER IS CONNECTED TO THE OUTPUT OF THE SI UNLESS IN BYPASS MODE, WHERE IT WILL BE COMPLETELY DISCONNECTED.

WHEN THE GRID IS PRESENT THE SMARB IS OFF AND THE SUNNY BOY(S) ARE CONNECTED TO THE AC IN BUS. WHEN THE GRID FAILS, THE TIME DELAY RELAY IS ACTIVATED. AFTER 5 MIN., THE SB, WHICH IS NOW OFF, IS SWITCHED OVER TO THE SI OUTPUT BY THE SMARB, THE SB SWITCHES BACK ON 5 MIN LATER IN OFF GRID MODE.

WHEN THE GRID RETURNS, THE LEG BREAKING RELAY BREAKS L1 OF THE SB THUS SHUTTING IT DOWN. THE DELAY RELAY THEN COUNTS 5 MIN AND THE SMARB DEACTIVATES WHICH BREAKS THE CIRCUIT TO THE LEG BREAKING RELAY SWITCHING L1 BACK TO THE SB AND CONNECTING THE NOW INACTIVE SB BACK TO THE GRID. 5 MIN. LATER, THE SB'S START TO SELL TO GRID.

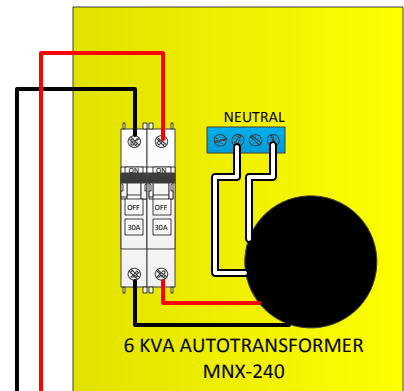

UNLESS OTHERWISE MARKED, ALL INTERNAL WIRING TO BE #6 COPPER THHN
ALL INTERNAL BREAKERS HAVE BEEN CERTIFIED BY MANUFACTURER FOR 100 % NAMEPLATE RATING IN THIS APPLICATION NO ADDITIONAL DE RATING IS NECESSARY

NOTE: EXTERNAL COMPONENT GROUNDS OMITTED FOR CLARITY TAKE IT ON FAITH THAT THEY ARE ALL PROPERLY CONNECTED

SMA Continuity check **WE WANT ALL AC POWER OFF AT THIS TIME FOR SAFETY**

With only the 2 15 amp breakers on.

L2 out bus bar to AC in L2 smarb

L2 in bus bar to AC out L2 smarb

L1 out bus bar to AC in L1 smarb

L1 in bus bar to AC out L1 smarb

From grid tie inverter red bus bar to GT in L2 smarb

From grid tie inverter black bus bar to GT in L1 smarb

L1 out to top of 3rd 15amp breaker

L1 In to the top of the 1st 15 amp breaker

L2 out to the top of the 4th 15 amp breaker

L2 in to the top of the 2nd 15 amp breaker

L1 out to A1 on delay relay

L1 out to S on delay relay

Neutral to A2 on the delay relay

When grid is present the Green LED will be on

When grid is not present the Green and Red LED will be on