

High Voltage DC-DC Converter

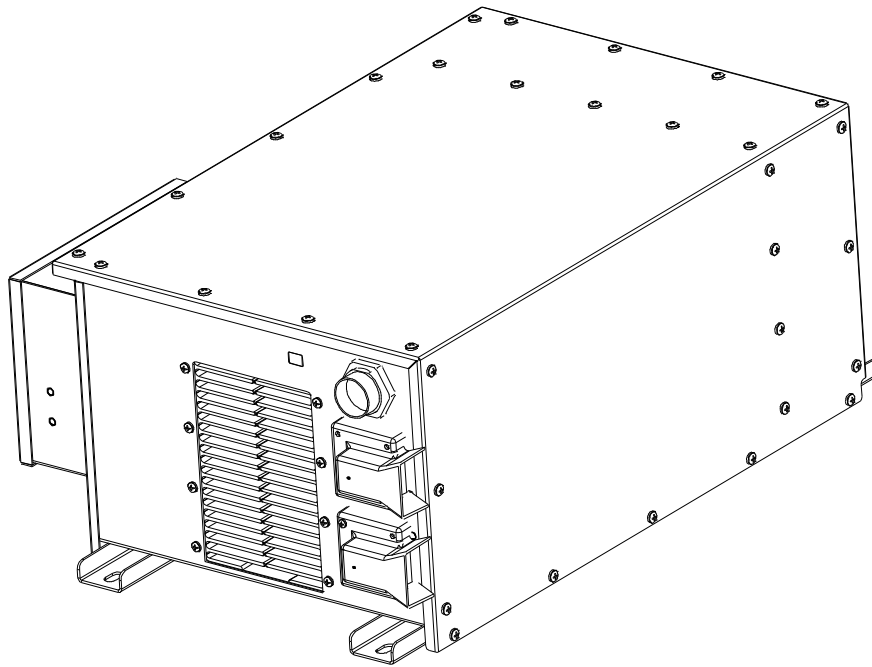

HBA (Hybrid Beltless Alternator)

Table of Contents

Introduction.....	3
Specifications.....	4
Operation.....	6
Installation Instructions.....	8
Testing and Troubleshooting.....	15
Vann-Bus Battery Management.....	20
Dual HBA System.....	24
CAN Bus Specification.....	27

Notes

Introduction

Thank you for purchasing Vanner's *High Voltage DC-DC Converter*. We are confident that you will be very pleased with its performance because Vanner products are designed and manufactured by skilled professionals using the highest standards in workmanship. With minimum maintenance and care, you can be assured of many years of trouble free service.

General Description

The Vanner *High Voltage DC-DC Converter* (commonly referred to as HBA in this document) is an efficient and highly reliable method of converting high dc voltage present in hybrid drive systems to low dc voltage (24V) for auxiliary batteries and loads. The converter is designed to be a direct replacement for a belt driven alternator to increase reliability and reduce maintenance costs.

The converter is J1939 CAN (Controller Area Network) enabled and is fully configurable and controllable over a J1939 compliant network but is also capable of autonomous operation. The converter is designed to monitor and report the status of several critical functions and provides real-time fault signals over the CAN bus to the vehicle electrical system controller.

A typical system includes a high voltage energy source (500 – 780VDC), a Vanner HBA and a low voltage battery bank for auxiliary loads. The HBA is provisioned with a two pin sealed connector for integration into the vehicle's high voltage interlock system and a fourteen pin sealed circular connector for CAN and vehicle I/O.

Paralleling: The outputs of two HBA's may be connected in parallel to double the output capacity of the 24V charging system. Please contact Vanner engineering and/or sales for the appropriate HBA model number for your dual application.

Specifications

High Voltage DC-DC Converter		
Model Numbers (250kbps)	HBA400-* and EBA400-*	HBA500-* and EBA500-*
Model Numbers (500kbps)	HBA-5-400-* and EBA-5-400-*	HBA-5-500-* and EBA-5-500-*
Single HBA Current Rating	250A	300A
Dual HBA Current Rating	500A	600A
Input Voltage Range (VDC)	500 – 780	
Input Voltage (VDC) – Full Power Out	550	600
Input Under-Voltage Range (VDC) Under-Voltage Current Limit Range (A)	See graph below	See graph below
Efficiency (At Maximum Power)	91%	
Max Input Current (AMPS)	15	17
Output Voltage Range (VDC)	24 - 30	
Max Output Current (AMPS)	250	300
Max Ripple Voltage (mV)	<100mV RMS	
Standby Current (Milliamps)	<20mA	
Cooling Method	Forced Air	
High Voltage Discharge	Upon removal of high voltage power source or terminal access cover, caps will discharge to 50 VDC or less within 30 seconds.	
Operating Temp.	-40°C to +60°C Full Power Output 80°C - Half Power Output	
Storage Temp.	-40°C to +85°C (-40°F to 185°F)	
Serviceable	Internal components to be serviced by Vanner personnel only. Fan filter/finger guard to be removed and cleaned of dirt/debris quarterly.	
Environmental Considerations IP55 Rated	Plated sheet steel enclosure provides protection against salt, fungus, dust, water, fuel vapors and all fluids associated with commercial and off-highway vehicle operations.	
Mounting Location	Mount on a flat surface (horizontal or vertical) close to the high voltage batteries to allow short cable runs.	
Weight (lbs.)	75 (34kG)	

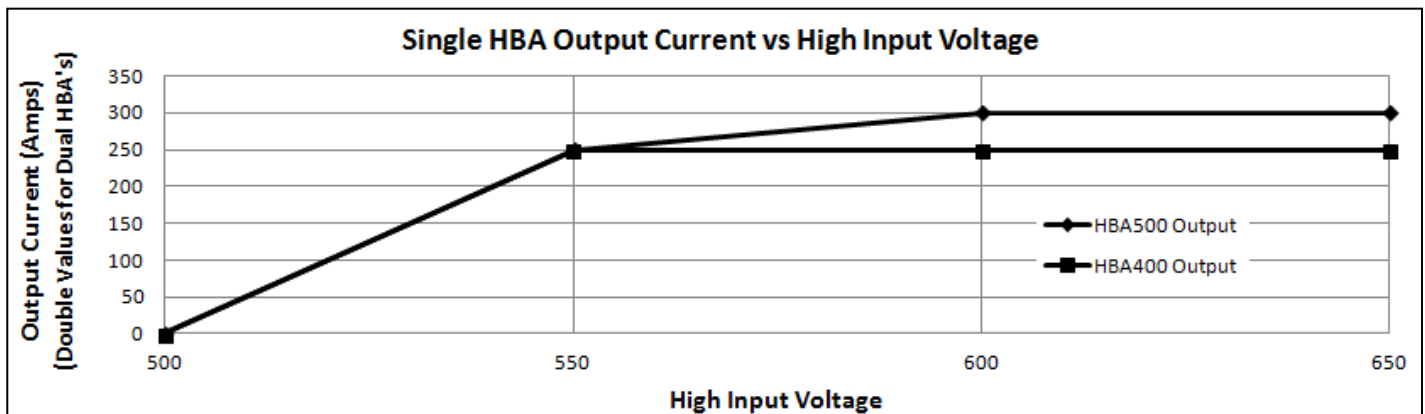

Dimensional Specifications (All Dimensions are in Inches)

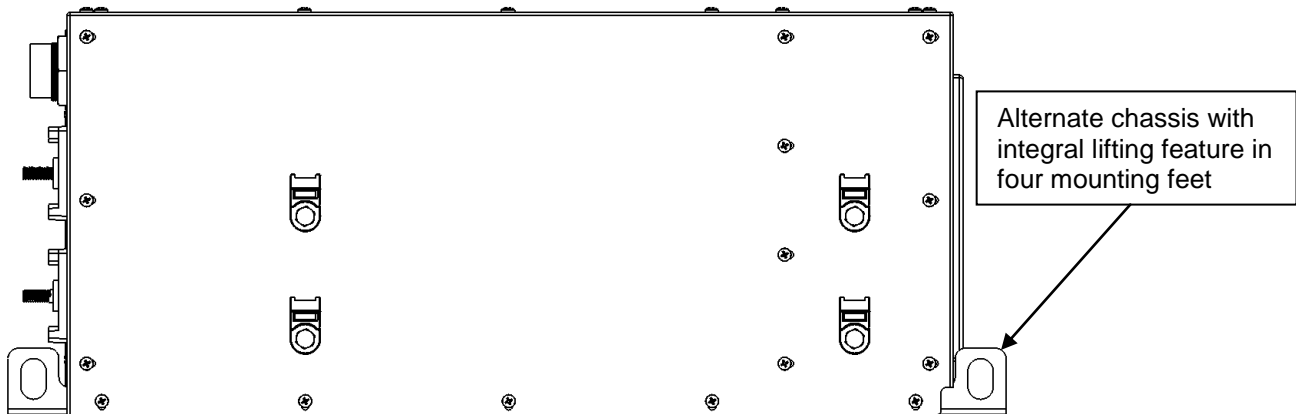
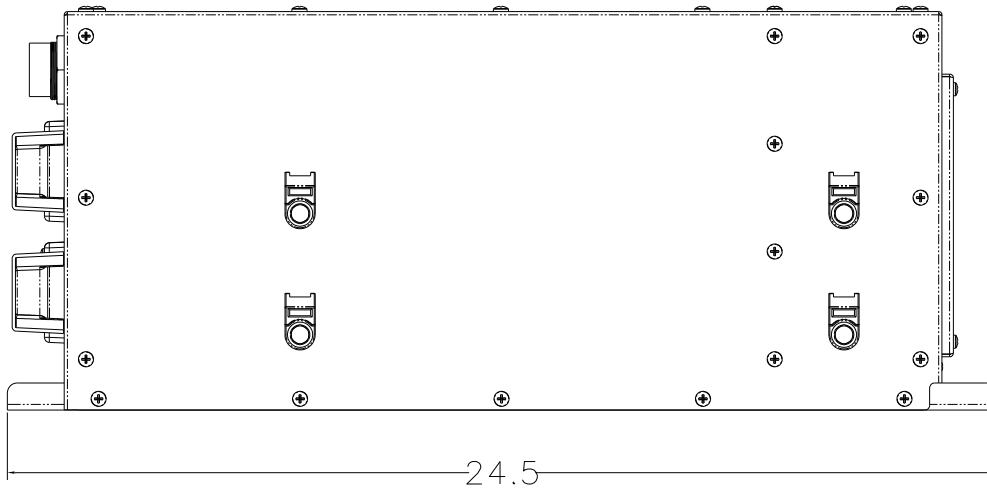
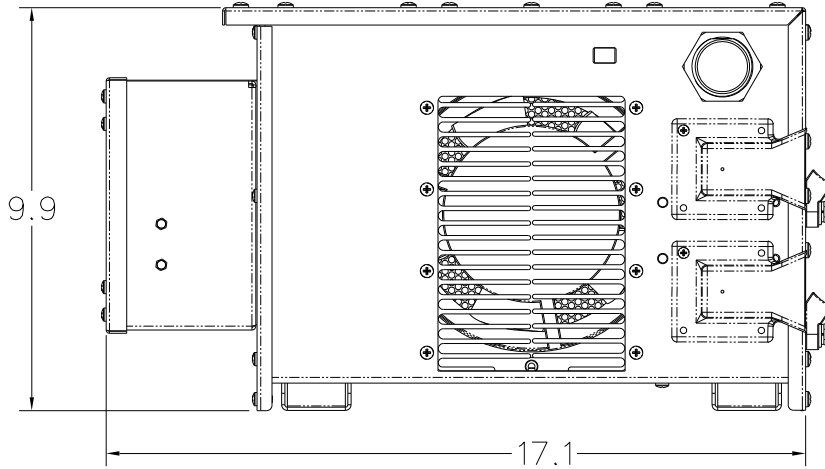

Operation

Converter Start Up/Normal Operation

In order for the HBA to start successfully, the following conditions must be met;

1. The low voltage battery shall be between 16 – 32 VDC.
2. The high voltage battery shall be between 500 – 800 VDC.
3. The converter must receive a +24V enable signal on Pin A of the circular I/O connector.
 - a. For vehicles with pre MY2013 engines, the wakeup signal may come from the engine oil pressure switch.
 - b. For vehicles with MY2013 engines or newer, the wakeup signal originates from the hybrid drive train transmission control module. Contact Vanner engineering for details.
4. The converter must receive a CAN message to turn on.
 - a. For vehicles with pre MY2013 engines; the HBA must receive an engine RPM signal via CAN message. The engine speed must be equal to or greater than 400 RPM for 0.1 second. (After start up, the HBA will shut down if the engine speed is less than 350 RPM for 4.0 seconds.)
 - b. For vehicles with MY2013 engines or newer; the HBA On/Off controls are handled via CAN message from the hybrid drive train controller. **Note:** Contact Vanner engineering for the latest version of the HBA CAN Messages Specification.

Normal Operation

The HBA can provide up to full rated output (250 or 300 amps) of continuous current and maintain 29 volts out across a DC input range of 550 – 800 volts. It can maintain this output in ambient temperature conditions of -40° to +60°C.

HV Battery Under Voltage Condition – 250A Unit

The DC to DC converter will begin to current limit if the input voltage drops below 550V. It will current limit linearly from 250A – 0A between 550V and 500V. (See chart on page 4.) The converter will shut down completely if the input voltage drops below 500V. Once the input voltage is equal to or greater than 550V, the converter will restart automatically.

HV Battery Under Voltage Condition – 300A Unit

The DC to DC converter will begin to current limit if the input voltage drops below 600 volts. It will current limit linearly from 300A – 250A between 600V and 550V. The converter will continue to current limit linearly from 250A – 0A between 550V and 500V. (See chart on page 4.) The converter will shut down completely if the input voltage drops below 500 volts. Once the input voltage is equal to or greater than 550V, the converter will restart automatically.

HV Battery Over Voltage Condition

The DC to DC converter will perform a soft shutdown if the input voltage is above 800V and below 850V. It will restart automatically once the input voltage drops below 750V.

If the input voltage exceeds 850V, the converter will “permanently” shutdown. The unit will not restart automatically if the input voltage drops below 750V, the ignition switch must be cycled off and on.

LV Battery Conditions

The low voltage battery must be greater than 16V but less than 32V for the HBA to start.

If the low voltage battery drops below 15V or goes above 32V, the HBA will perform a soft shutdown. The converter will restart automatically if the voltage returns to the normal operating range of 16 – 32V.

Overload Condition

The HBA is current limited to its rated output current (250 or 300 amps). If the 24V load exceeds the HBA's rated output current, it will continue to provide its rated output current until the battery voltage falls below 20V. If the battery voltage falls below 20V the HBA will current limit at 90 amps. If the battery voltage falls below 16V the HBA will shut down.

Output Short Circuit Protection

There are three ways that the output of the HBA is protected from short circuits.

1. The output current increment is monitored and if the rate is above 10A / 100 μ s, the HBA will perform a soft shutdown.
2. A comparator will generate an over-current signal if the current in the high voltage side of the transformer exceeds 70A. The HBA software will detect this signal and the HBA will perform a soft shutdown.
3. Hardware will detect an over current condition. Once the current in the high voltage side of the transformer reaches 90A, the HBA will perform a soft shutdown.

The HBA will automatically restart upon removal of the fault condition.

Thermal Protection

The temperatures of critical components within the HBA are continuously monitored. The highest temperature of these components will be used for temperature control.

During light load conditions (less than 80% of the nominal current rating) the cooling fan will be turned on at 75°C and turned off at 70°C.

During high load conditions (greater than 80% of the nominal current rating) the cooling fan will be turned on at 70°C and turned off at 65°C.

The HBA will shut down if any of the following conditions exist:

- temperature on the low voltage power stage reaches 82°C, or
- * temperature on the high voltage power stage reaches 98°C, or
- * temperature on the control board reaches 98°C

The HBA will restart automatically if all of the following conditions exist:

- temperature on the low voltage power stage drops below 78°C, and
- temperature on the high voltage power stage drops below 92°C, and
- temperature on the control board drops below 92°C

- * The output of the HBA will current limit if the temperature on the high voltage power stage and control board is below 98°C but above 92 degree C. The output current will be incrementally reduced to avoid thermal shutdown conditions.

Installation Instructions

These symbols are used to note procedures that if not closely followed could lead to loss of life or damage to equipment or property due to electrocution.



Electrocution hazard exists



Fire hazard exists



A potentially dangerous condition



Explosive hazard exists



Corrosive hazard exists



Do not exceed the specified torque of 100 lb-in when connecting cables to the 5/16-18 terminal posts (± 24 and $\pm 600V$) during installation of the HBA. Torque values higher than specified may damage the product, reduce performance, and/or create hazardous conditions. Products damaged by improper torque are not covered by the warranty.



Do not connect more than one conductor per terminal post on Vanner HBA. Multiple wires and cables may overstress internal components, resulting in poor performance or creating hazardous conditions. Products damaged by the installation of multiple conductors per post are not covered by the warranty.



Fault protection devices must be installed between the HBA and the power source (battery). A fault protection device would be any fuse or circuit breaker properly rated for the maximum DC current obtainable. This advisory is in accordance with SAE, NEC and UL, for mobile power applications. Install per applicable codes or within 18" of the battery. See Wire and Fuse Sizing Chart on page 13 of this manual or contact Vanner at 1-800-227-6937 or pwrsales@vanner.com if assistance is needed in sizing fault protection devices.



Caution: This equipment tends to produce arcs and sparks during installation. To prevent fire or explosion, compartments containing batteries or flammable materials must be properly ventilated. Safety goggles should always be worn when working near batteries.



Mounting Location –The HBA must be mounted on a flat horizontal or vertical surface suitable for support during application. The HBA must be mounted under a cover to protect it from direct exposure to the elements, i.e., rain, sun, sleet/snow. Do not mount in a zero-clearance compartment that may result in overheating. Care should also be taken when selecting a mounting location to ensure the fan inlet and outlet locations are not blocked. A minimum of four inches should be allowed at fan inlet and outlet. Locate the HBA so that contact by unauthorized personnel is unlikely.

Mounting Dimensions (Bottom View – Dimensions are in Inches)

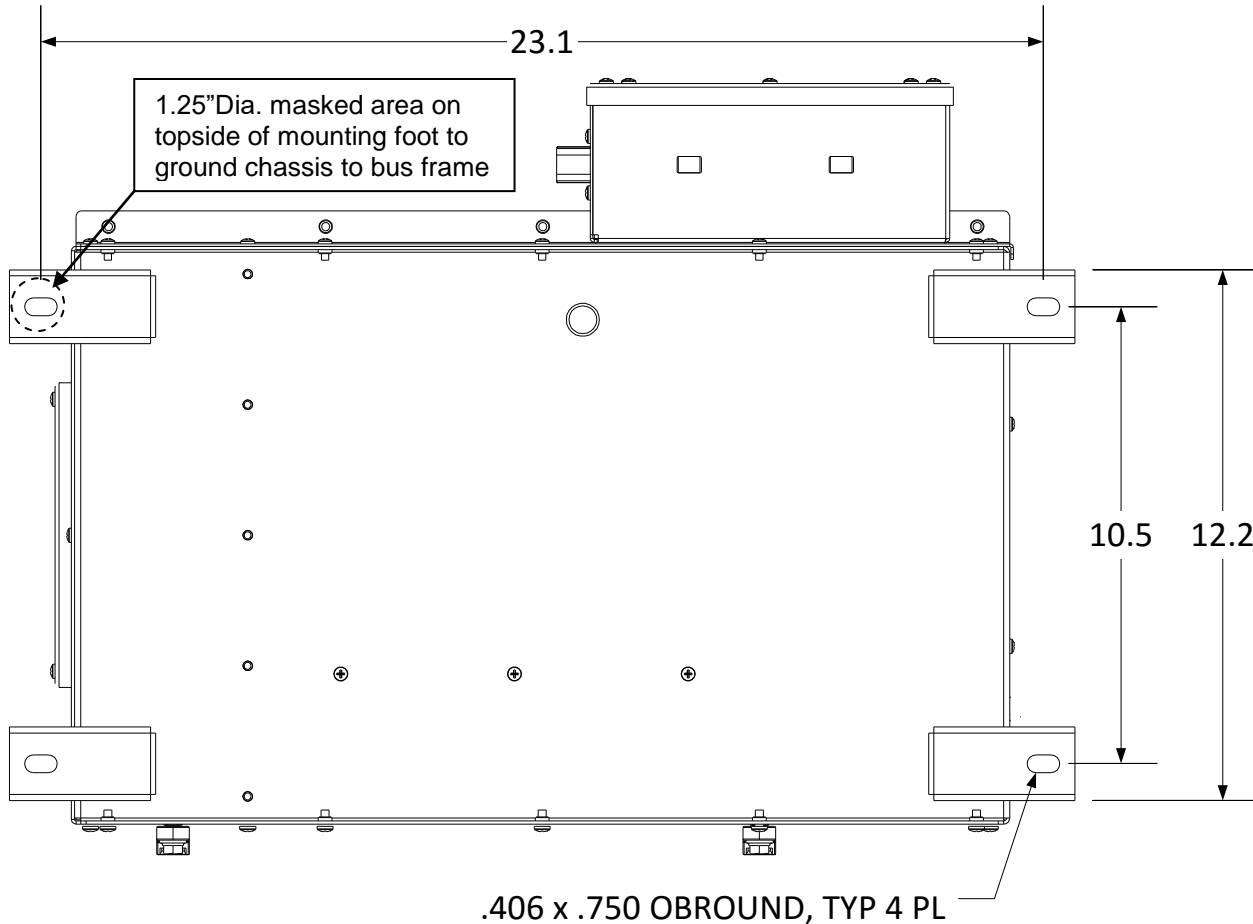

Environmental Protection

Although your *HBA* has been designed to an IP55 rating, it must be mounted under a cover to protect it from direct exposure to environmental elements such as sun, rain, sleet and snow. The converter has also been designed for exposure to direct pressure spray, but continual exposure to direct pressure spray may reduce the serviceable life. Any damage due to water contamination is covered by Vanner only through the terms of the factory warranty.

Wiring Sequence

High Voltage Input: The *HBA*'s high voltage input is internally protected for reverse polarity.

24V Output: The *HBA*'s 24V output is not reverse polarity protected. The *HBA* will be damaged if the 24V battery is connected to the *HBA* with the positive and negative reversed. To protect the positive cable, it shall be fused as close to the battery as practical.

Wiring Input/Output Definitions

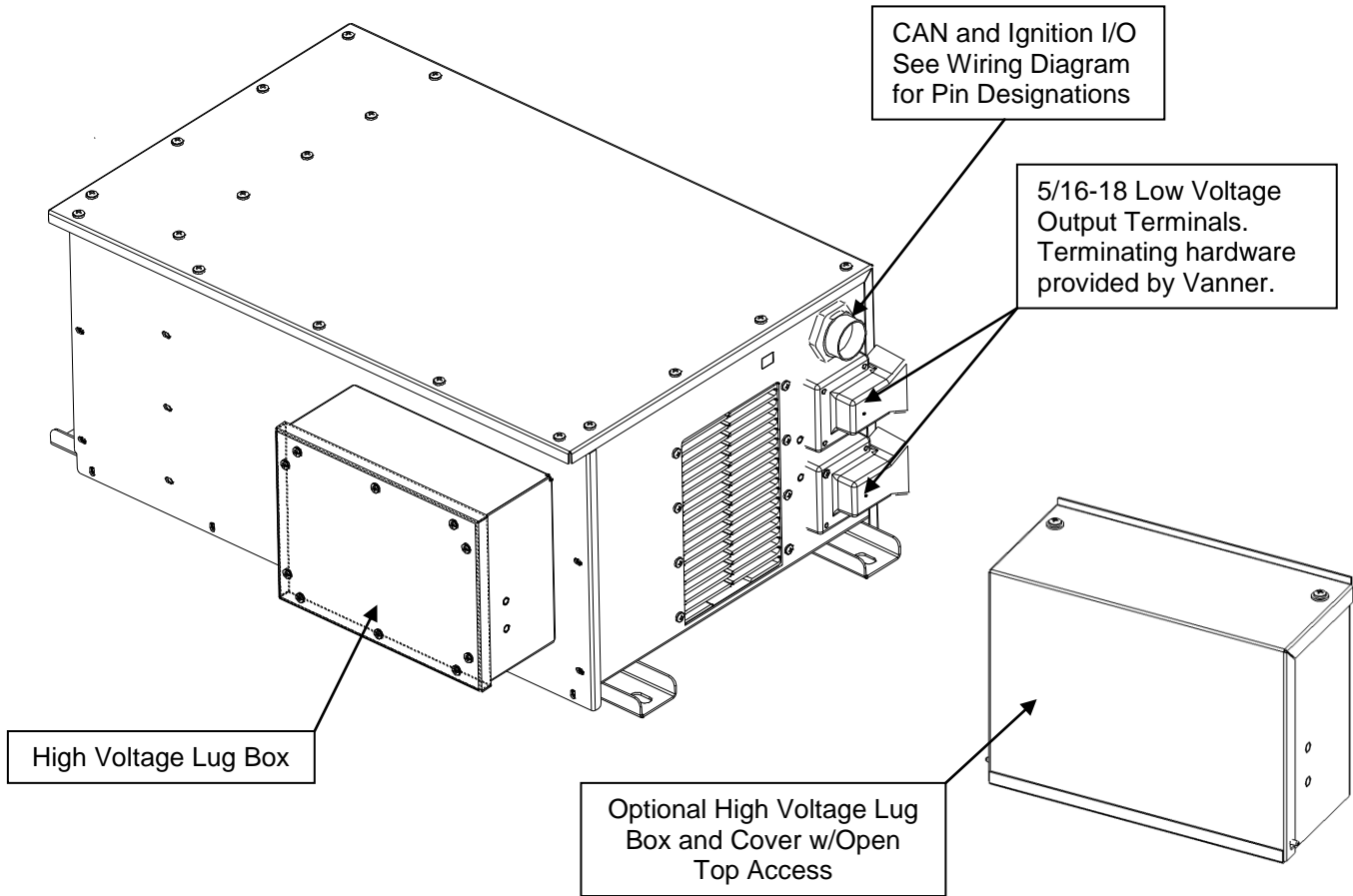

Low Voltage Output Terminal Designations

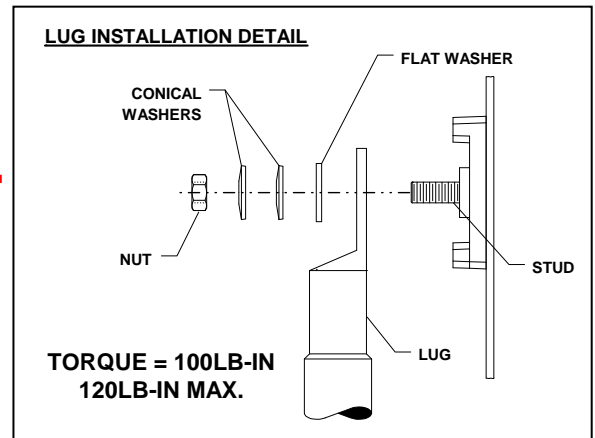
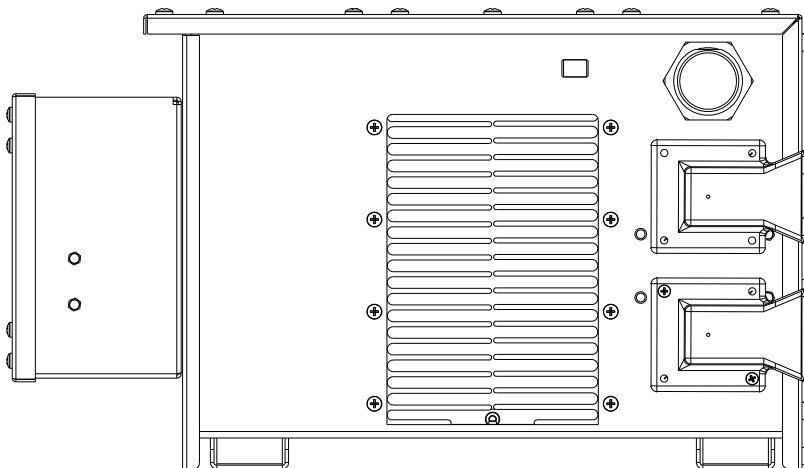

High Voltage Input and Interlock Designations

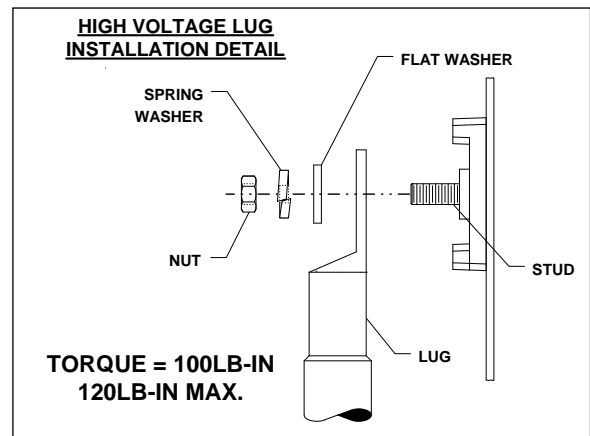
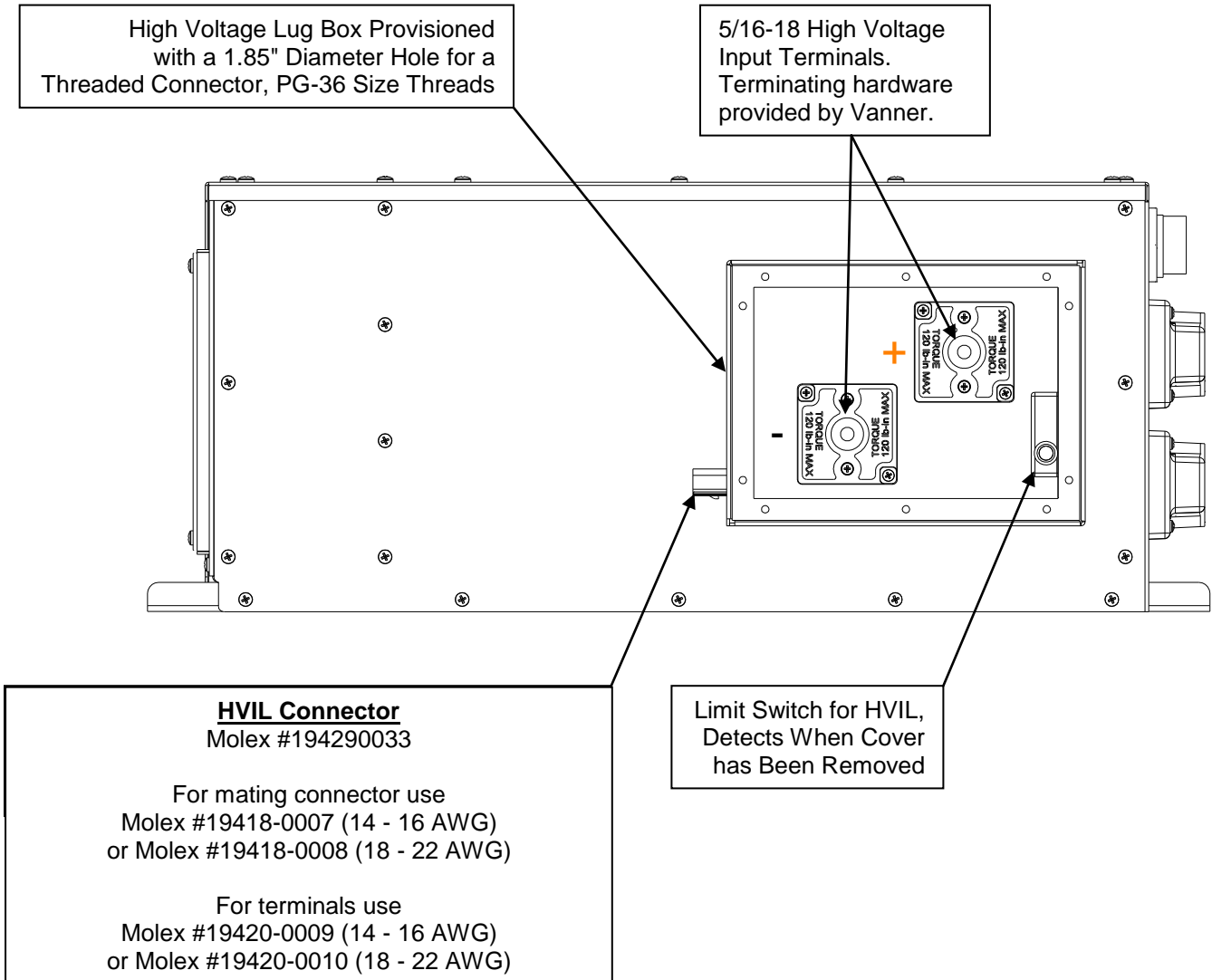

HBA Wiring Diagram w/Vanner 70 Series Equalizer

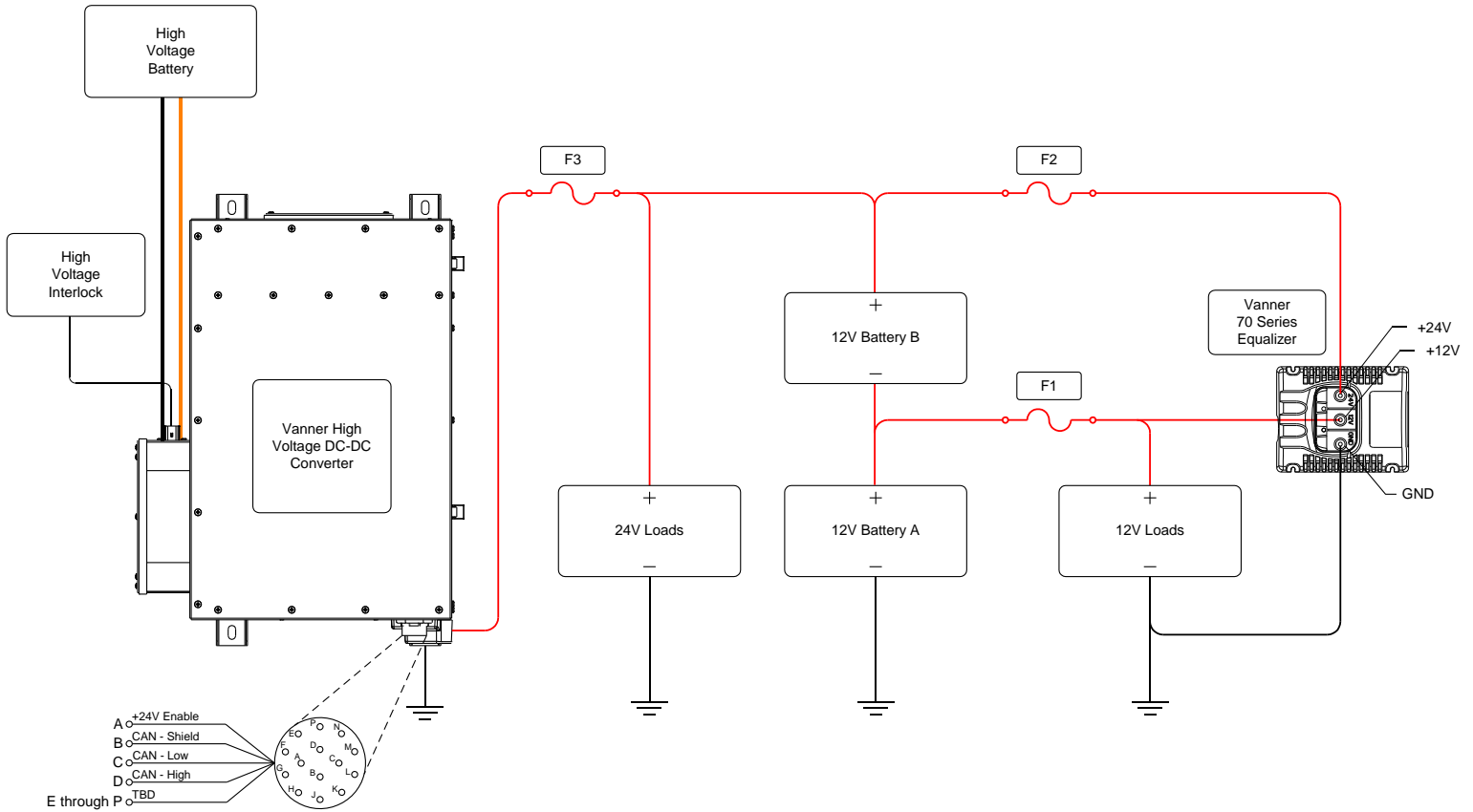

I/O Definitions and Functionality (Pins E through P are Optional)

A. +24V Enable Input

This input “wakes up” the HBA and must be present for the HBA to turn on.

B. CAN Shield

This connection is used to make the shield on the CAN cable common. This is required for electrical noise considerations in vehicle electrical systems.

C. CAN Low

This is the low signal connection for the vehicle’s CAN bus. The HBA will communicate faults to the vehicle’s electrical system controller via the CAN bus.

D. CAN High

This is the high signal connection for the vehicle’s CAN bus. The HBA will communicate faults to the vehicle’s electrical system controller via the CAN bus.

E through L - TBD

M. For DUAL HBA Installations only. (See wiring diagram on page 24.)

Installing a jumper between Pins M and N designates the HBA as the PRIMARY unit.

N. For DUAL HBA Installations only. (See wiring diagram on page 24.)

Installing a jumper between Pins M and N designates the HBA as the PRIMARY unit.

Installing a jumper between Pins N and A designates the HBA as the SECONDARY unit.

P. TBD

Note: The HBA I/O connector is a panel mounted Deutsch receptacle P/N: HDP24-18-14PN. A typical mating connector is Deutsch plug P/N: HDP26-18-14SN provisioned with Deutsch socket contacts P/N: 1062-16-0622. The Deutsch part numbers for the mating plug and contacts will vary depending on the wire gauge, insulation type and back-shell used. Select the proper sealing ring option for the wire insulation diameter to ensure proper sealing.

Wire Size and Temperature Rating

Cables connecting the HBA to the 24V batteries must be sufficiently sized to prevent unwanted voltage drop. The temperature rating of the wire should be a minimum of 90°C.

Vanner recommends the following wire and fuse sizes for the 250A and 300A HBA's. To protect the positive cable, it shall be fused as close to the 24V battery as practical.

HBA Low Voltage Output Wire and Fuse Size Chart

Wire Size AWG	Ring Terminal Panduit	Fuse F3
#4/0	*LCD4_0-56000-CUST	400 amp

* The Panduit part number listed is recommended, not required, by Vanner. Equivalent substitutes may be used. Contact Vanner engineering for a drawing of the Panduit ring terminal.

The recommended terminal is a right angle lug that enables the installer to route the 4/0 cables along the side of the HBA. Factory installed tie wrap bases are present on the side of the HBA for strain relief.

Crimp the ring terminals using **Panduit CT-930** manual/hydraulic crimping tool. Use **Panduit** die **CD-920-4/0** die. (Purple P54).

Testing and Troubleshooting

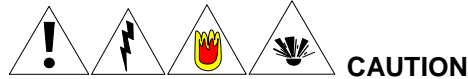

Servicing of electrical systems should only be performed by trained and qualified technical personnel.

Equipment Required

Required: A laptop provisioned with Vanner's Dashboard software, supporting hardware and interface cables.

Note: There are kits available for purchase that include Vanner's Dashboard software, a USB to CAN adapter module and a harness to connect to the vehicle's CAN network. Please contact Vanner's inside sales department for the appropriate kit part number for your application.

Optional: Volt Meter having 0.01 volt resolution. (Fluke Model 87 Multimeter recommended).
Clamp-on current meter (Fluke Model 36 Clamp-on Meter recommended).

Test Procedure for HBA

The HBA is working properly if:

1. The 24 volt DC loads are being operated continuously and are within the rated capacity of the HBA and;
2. The power drawn from the hybrid drive train system is within its rated capacity.

HBA Test Procedure:

1. Field-test the HBA while fully connected to the vehicles high and low voltage batteries.
 - The 24V battery must measure between 16 and 32 volts. If the 24V battery is below 16 volts, apply a 24 volt battery charger to the batteries.
 - The high voltage battery must measure between 500 and 780 volts for the HBA to start properly.
2. Start the vehicle normally while monitoring the HBA status with a laptop provisioned with Vanner's Dashboard software. The laptop must be connected to the vehicle CAN Bus utilizing a USB to CAN adapter and harness.
 - The HBA will turn on automatically upon receiving the engine RPM signal or CAN On/Off command via CAN bus and a +24V enable signal.
 - Upon normal system startup, the output voltage will increase to 28.5 volts and the output current will increase indicating charging of the 24V batteries and providing power for the 24V auxiliary loads.
3. The Vanner Dashboard software monitors the following data which can be observed on the laptop;

High Input Voltage

High Input Current

Low Output Voltage

Low Output Current

Engine RPM

Heartbeat

Power Stage Temps.

Control Board Temp

CAN On/Off Command Message Status

Converter Status and Faults

Dashboard screenshot of a system under normal operating conditions

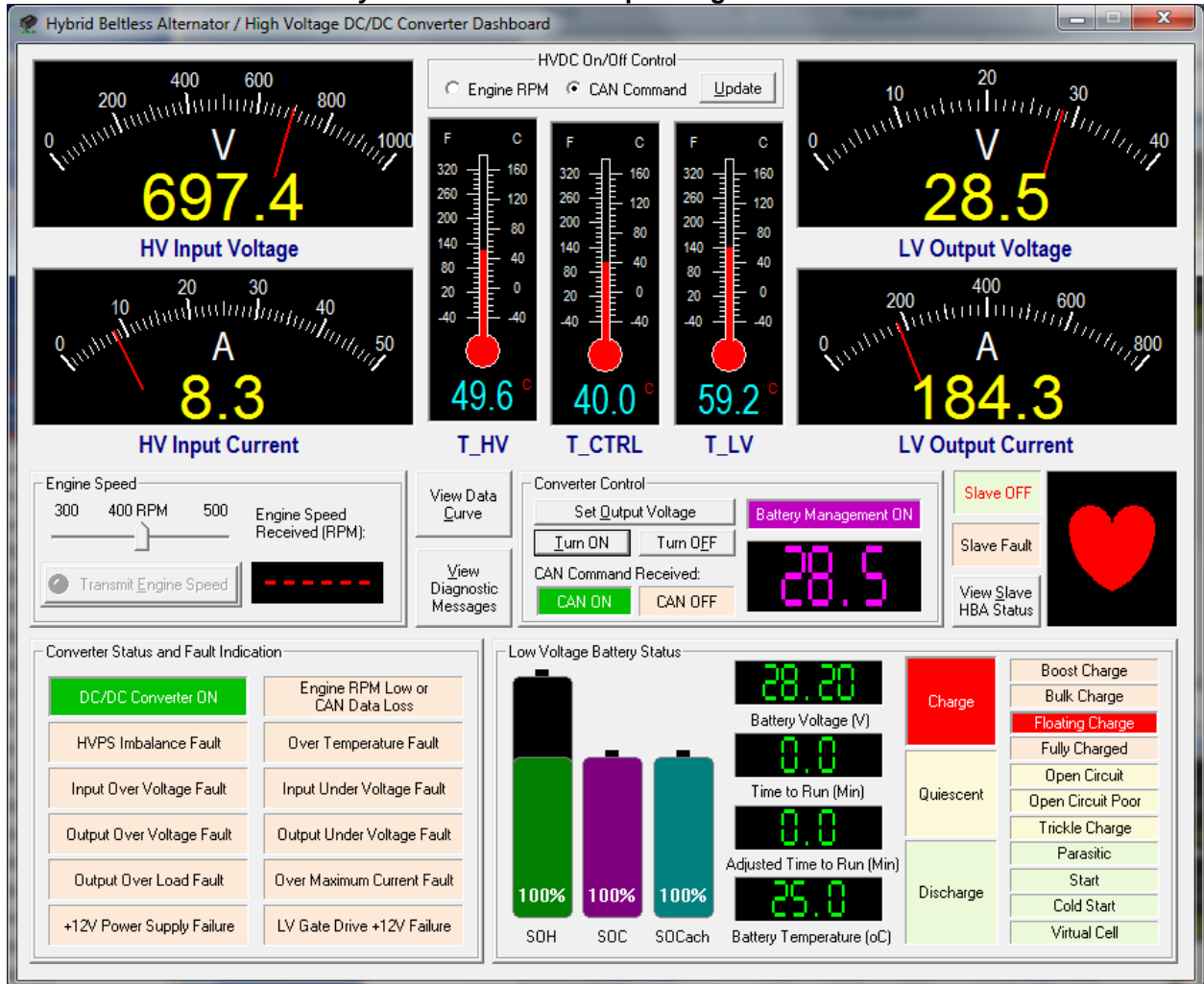

- If the Vanner Dashboard software isn't utilized or available, proper start up can be validated by measuring the 24V output terminals with a Volt Meter. Upon start up, the voltage will increase from the 24V battery nominal value up to ≈ 28.5 volts. **Note:** The measurement is dependent on the voltage drop in the cables/bolted connections between the HBA output terminals and the 24V battery terminals.
- A clamp on style current meter can also be used to validate the output current of the HBA.
- Important:** The high voltage terminals are inaccessible for measurement. A high voltage interlock circuit is implemented for safety purposes to prevent an accidental and potentially lethal shock to personnel. The high voltage input to the HBA can only be read via the Dashboard software.

Trouble Shooting an HBA No-Start Situation

In the event the Vanner HBA does not start, the following need to be reviewed/validated;

1. Is the high voltage battery within the acceptable input range? 550 - 780VDC
2. Is the 24V battery within the acceptable range? 20 – 32VDC
3. Is 24V battery voltage present at the output terminals of the HBA upon closing the battery disconnect switch?
4. If not, verify the fuse between the 24V battery and the HBA is installed and hasn't cleared.
5. Upon startup of the engine, does the 24V battery remain within the acceptable range? If the health of the 24V batteries is questionable, the voltage may collapse below 20 volts before the HBA starts. There is an approximate 2 - 3 second delay from the time the engine starts to the start of the HBA.
6. Is the +24V enable signal present at the I/O connector?
7. If the +24V enable signal is present, is the wire in the proper location of the mating I/O connector?
8. For vehicles with pre MY2013 engines: Is the engine rpm data being transmitted properly via the CAN Bus? PGN 61444 (0xF004)
9. If so, is the engine rpm greater than 400 rpm?
10. For vehicles with MY2013 engines or newer, is the "Converter Control" command message being received? PGN 65498 (0xFFDA)
11. If the answers to 5 and 6 are yes, are the CAN signal wires (HI,LO and Shield) in the proper locations of the mating connector?

HBA Status and Fault Indication Definitions

The HBA monitors several status and fault conditions. If any faults occur, they are reported via CAN bus and can be observed with the Dashboard software. The HBA status and fault indications in the lower left corner of the screenshot on page 16, are defined as follows;

DC/DC Converter ON: Green indication that HBA has turned on successfully

DC/DC Converter OFF: Red indication that HBA is off. If the reason is due to a fault, that condition will be indicated by a red icon.

Engine RPM/ Low or CAN Data Loss: The HBA will perform a soft shutdown if the engine speed drops below 350 RPM for four seconds or there is a loss of CAN communication. The HBA will restart automatically when the engine speed exceeds 400 RPM for 0.1 seconds or CAN communication is restored.

HVPS (High Voltage Power Stage) Imbalance Fault: Internal circuitry detects if the voltage differential between the center point to negative and center point to positive is excessive, > 200V. If an imbalance fault is detected, the HBA will "permanently" shut down. The unit will not restart automatically if the imbalance condition clears, the ignition must be cycled off and on. See note below.

Note: An imbalance fault can be caused by leakage current or a defective detection circuit within the HBA. However, the HBA will also detect external leakage paths. The external leakage path could be caused by water ingress in a high voltage cable assembly or junction box. It could also be caused by damaged shielding on a high voltage cable assembly. If the high voltage imbalance fault does not clear after cycling the ignition, Vanner recommends inspecting the high voltage cable assemblies for leakage paths.

Over Temperature Fault: The HBA will perform a soft shutdown if any of the following conditions exist: the temperature on the low voltage power stage reaches 82°C, or the temperature on the high voltage power stage reaches 98°C, or temperature on the control board reaches 98°C. The HBA will restart automatically if all of the following conditions exist: the temperature on the low voltage power stage drops below 78°C, and the temperature on the high voltage power stage drops below 92°C, and the temperature on the control board drops below 92°C.

HBA Status and Fault Indications Cont'd

Input Overvoltage Fault: The HBA will perform a soft shutdown if the input voltage is above 800V and below 850V. It will restart automatically once the input voltage drops below 750V. If the input voltage exceeds 850V, the converter will “permanently” shut down. The unit will not restart automatically if the input voltage drops below 750V, the ignition switch must be cycled off and on.

Input Under Voltage Fault: The HBA will perform a soft shut down if the input voltage drops below 500V. Once the input voltage is equal to or greater than 550V, the converter will restart automatically.

Output Overvoltage Fault: The HBA will perform a soft shutdown if the low voltage battery exceeds 32V. The HBA will restart automatically if the voltage returns to the normal operating range of 16 - 32V.

Output Under Voltage Fault: If the low voltage battery drops below 15V, the HBA will perform a soft shutdown. The converter will restart automatically if the voltage returns to the normal operating range of 16 – 32V.

Output Overload Fault: The HBA is current limited to 250A or 300A. If the load is above 250A or 300A, the unit will begin current limiting and gradually reduce the output voltage. Once the HBA output voltage decreases to a value less than or equal to the battery voltage, the batteries will begin to assist in supporting the load. If the load continues to increase and the output voltage drops to 20V, the output current will begin to fold back. If the output or battery voltage is reduced to 16V, the HBA will turn off. The HBA will restart automatically if the loads are reduced and the battery voltage returns to the normal operating range of 16 - 32V.

Over Maximum Current Fault: The HBA will perform a soft shutdown if the current flowing through an internal power stage current transformer exceeds 90A. The HBA will restart automatically if the current returns to a value below 90A.

+12V Power Supply Failure Fault: The HBA will perform a permanent shutdown in the event of a +12V power supply failure. The unit should be replaced and the failed unit returned to Vanner for evaluation.

LV Gate Drive +12V Failure: The HBA will perform a permanent shutdown in the event of a LV Gate Drive +12V power supply failure. The unit should be replaced and the failed unit returned to Vanner for evaluation.

Testing an HBA for an Isolation Fault

In the event the vehicle is experiencing an isolation fault, the HBA should be eliminated as the cause of the fault prior to replacing any hybrid drive components. The isolation resistance of an HBA can be tested using an Amprobe AMB-45 Megohmmeter, commonly referred to as a "megger".

WARNING! The Vanner HBA uses potentially lethal voltages for operation. **DO NOT** attempt to test the HBA unless you have been trained to work with the Allison H 40/50 EP system.

1. Before beginning, reference Allison Transmission's "Electrical Disconnect Verification Procedure" for the H 40/50 EP product family. It contains important steps that are not covered in these instructions.
2. High Voltage Personal Protective Equipment (PPE) must be worn for this procedure.
3. Assure that the vehicle ignition switch is in the OFF position.
4. Assure that the vehicle master battery disconnect switch is in the OFF position. Use lockout devices to assure the switch cannot be moved to the ON position until the test procedure is complete.
5. Disconnect the high voltage positive and negative cables from the HBA input studs.
6. Insulate the ring terminals.
7. Do not disconnect the 24V positive and negative cables, 14 pin Deutsch connector, and chassis GND from the HBA. **Note:** If bench testing, connect HBA 24V negative to HBA chassis.
8. Set the AMB-45 to the 250V scale.
9. Connect AMB-45 negative to HBA chassis.
10. Connect AMB-45 positive to HBA high voltage positive stud. Measure and record resistance.
11. Connect AMB-45 positive to HBA high voltage negative stud. Measure and record resistance.
12. See table below for proper resistance readings.
13. If either resistance reading is significantly lower than specified, the HBA may be defective and should be returned to Vanner for repair.

HBA Serial Number	Positive to Chassis	Negative to Chassis	Actual Measurement
Prior to 13246-250093	810k Ω \pm 10%		Pos to Chassis: Neg to Chassis:
After 13246-250093	2.8M Ω \pm 10%		Pos to Chassis: Neg to Chassis:

Vanner Repair Service

Vanner offers a quick turnaround factory repair service. Send the unit to the address on last page with a note instructing us to repair it. Include your name, phone number, shipping address (not a P.O. Box Number), and your purchase order number.

Vann-Bus Battery Management

Vanner 80 Series Equalizer and Sensors

A vehicle with 12 and 24 volt loads may be provisioned with the following Vanner parts to permit dynamic voltage regulation of the HBA.

1. 80 Series Equalizer

When connected to the I/O of the current and voltage/temperature sensors listed below, the 80 series equalizer utilizes Vanner's MBBM (Model Based Battery Monitoring) algorithm to determine the SOH (State of Health) and SOC (State of Charge) of the 12 and 24 volt batteries.

The equalizer will communicate the appropriate voltage requirement, based on the battery manufacturers data, to the HBA which will adjust its output accordingly. The voltage requirement communicated to the HBA is based on the voltage at the battery terminals, therefore, voltage drop contributed by the cables and bolted connections is taken into consideration.

Note: The appropriate battery model must be loaded in the equalizer for maximum accuracy of the SOH and SOC calculations. Please contact Vanner for a library of batteries that are modeled to ensure the proper equalizer part number is ordered or the proper battery profile is loaded in memory.

2. Dual Current Sensor (80A/600A)

The dual current sensor, VSS-C80/600, monitors the current flowing into and out of the 24V battery.

3. Single Current Sensor (80A)

The single current sensor, VSS-C80, monitors the current flowing into and out of the 12V battery.

4. Voltage and Temperature Sensor

The voltage and temperature sensor, VSS-VT, monitors the 12V battery voltage as well as the temperature. It is mounted to the positive terminal of the 12V battery.

See page 21 for the HBA/Equalizer wiring diagram with the addition of the sensors and their pinout definitions.

Operational Theory

There are two operating modes for the HBA, standalone and battery management. If battery management is turned off or CAN messages from the equalizer/battery monitor are not received, the HBA defaults to standalone mode and regulates the output voltage locally at a fixed value. **Note:** the factory default is 28.5V but is user configurable via the dashboard interface.

In battery management mode, the output voltage reference is adjusted to regulate the output voltage remotely at the battery. The reference is adjusted at a rate of 0.1V/second. The upper limit of the reference voltage is 1.0V above the standalone output voltage.

If the battery SOC is 100% or the battery status is quiescent (quiescent is defined as when there is less than 5 amps going into or out of the batteries), the remote voltage is set to the float voltage value. Otherwise it is set to the absorption voltage value. The float voltage and absorption voltage are adjusted automatically with temperature according to a pre-defined curve.

Enabling Battery Management

Battery management is enabled through Vanner's dashboard interface. At the HBA startup screen, verify the "Battery Management" status is "On". If it is off, select the "Set Output Voltage" icon to turn it on.

Note: The default factory setting is "On". Battery Management only works if an 80 series equalizer and sensors are installed.

Note the low voltage battery status information displayed in the lower right corner of the screenshot below. The battery terminal voltage, state of health (SOH), state of charge (SOC) are all displayed as well as the charging modes, Charge/Quiescent/Discharge. Also note the difference in the battery voltage (27.8) and HBA voltage (28.3). This difference (0.5V) reflects the voltage drop in the cable/bolted connections between the HBA output terminals and the battery terminals at the indicated load of 125.9 amps.

Screenshot of HBA Dashboard with Battery Management "ON"

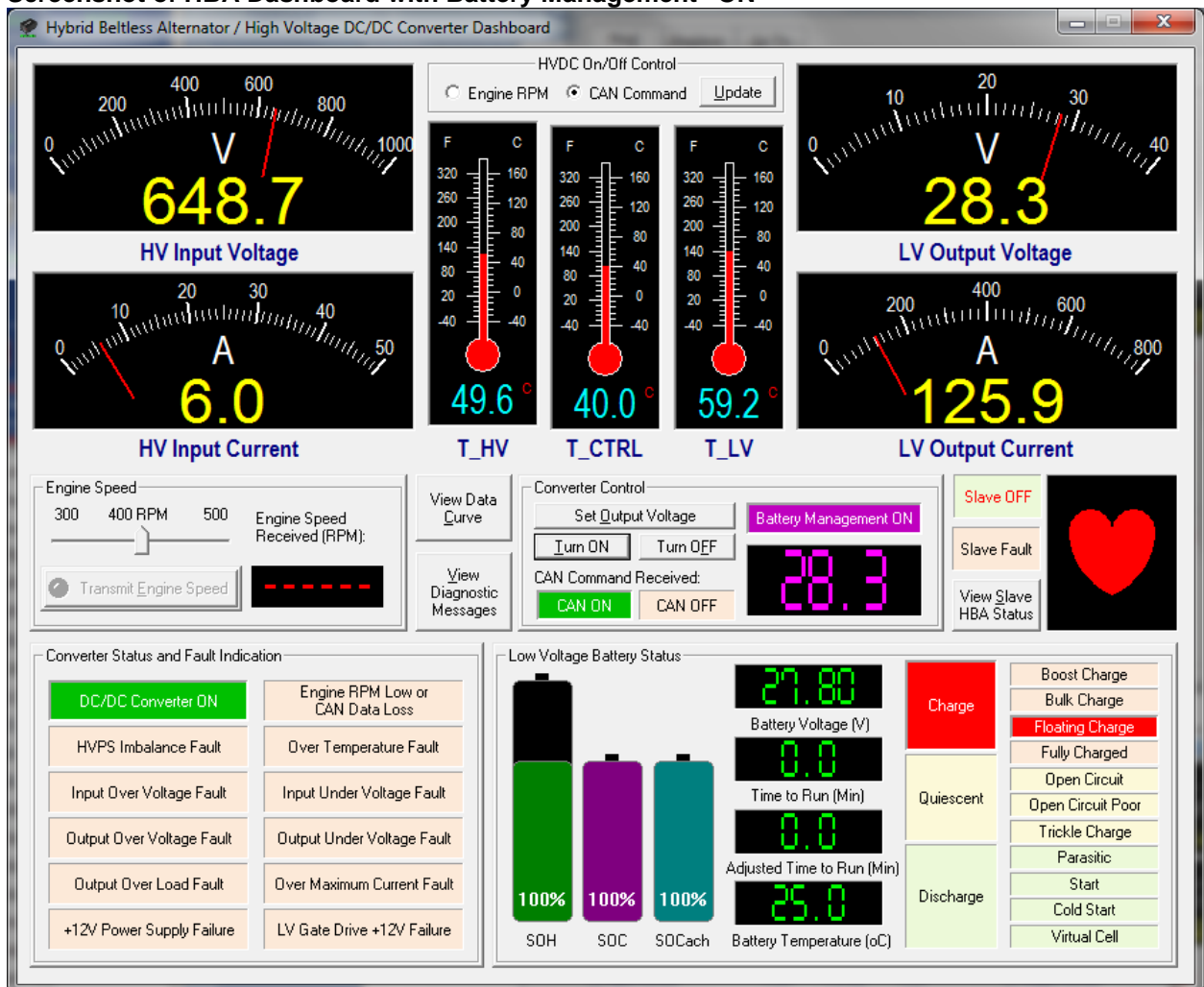

HBA Wiring Diagram w/Addition of Vann-Bus Sensors

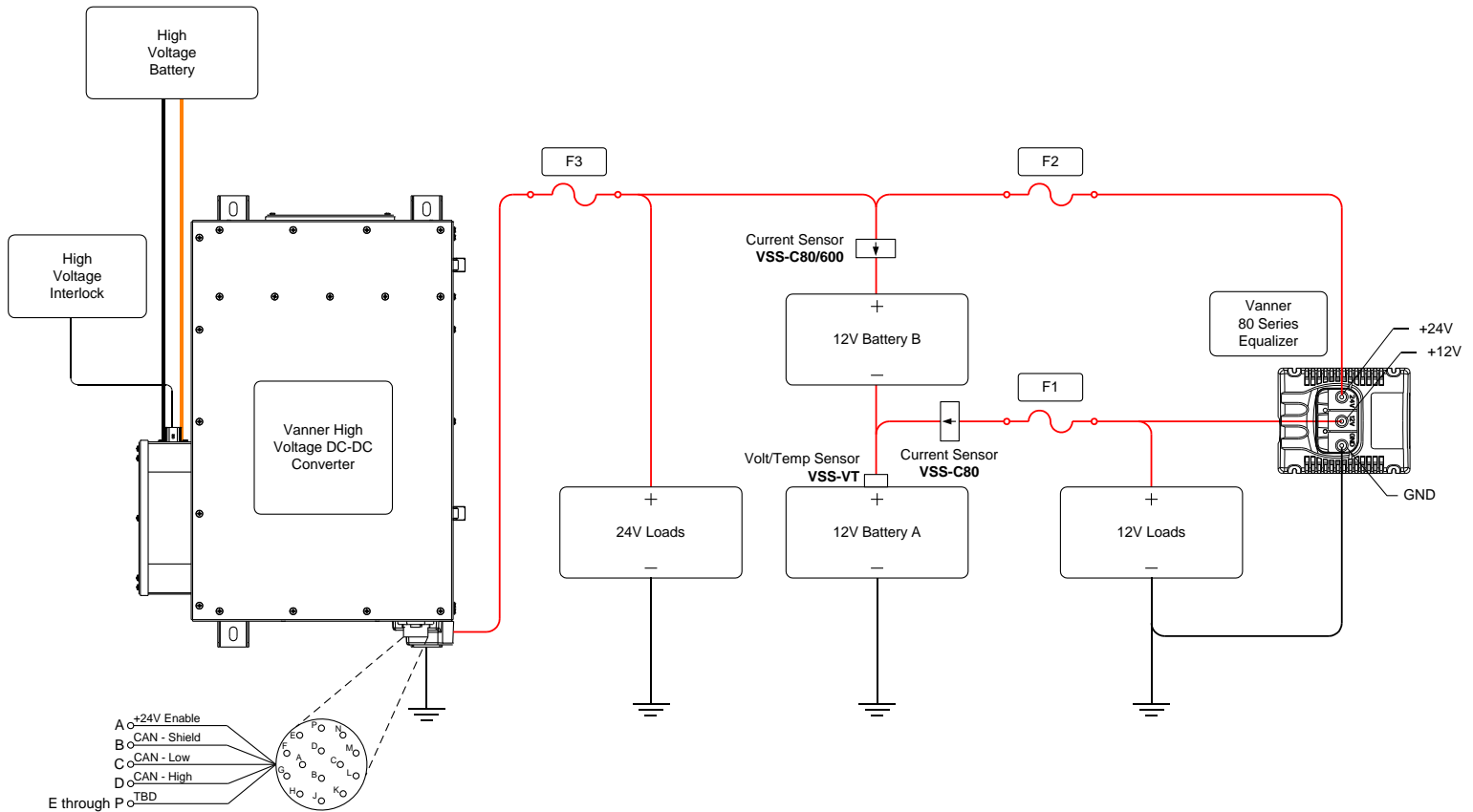

Pinouts for 80 Series Equalizer and Vann-Bus Sensors

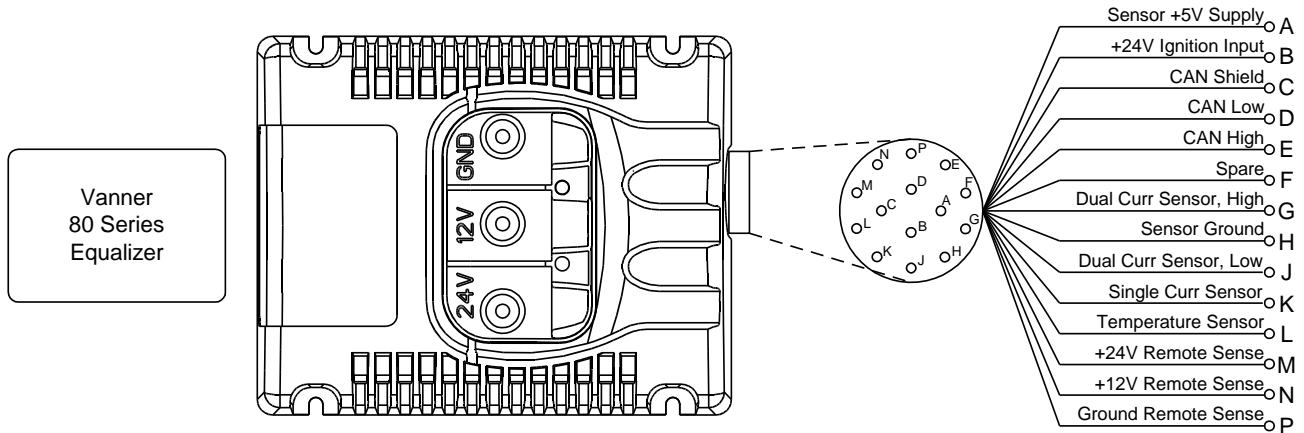

Voltage/Temperature Sensor Pinouts (VSS-VT)		
Sensor Pin #	Description	Equalizer Pin Letter
1	+5V Input	A
2	Ground	H
3	Temperature Sense	L
4	Fused +12V (From Bus Bar)	N

Voltage/Temp Sensor

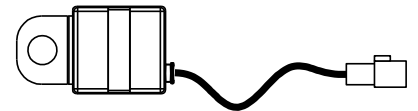

80A Single Current Sensor Pinouts (VSS-C80)		
Sensor Pin #	Description	Equalizer Pin Letter
1	+5V Input	A
2	Ground	H
3	Current Sense	K
4	Spare	-

Dual and Single Current Sensor

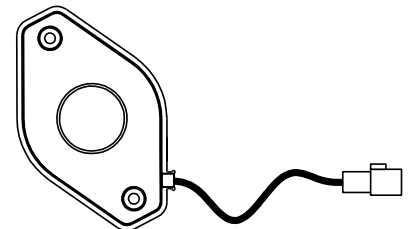

80/600A Dual Current Sensor Pinouts (VSS-C80/600)		
Sensor Pin #	Description	Equalizer Pin Letter
1	+5V Input	A
2	Ground	H
3	Current Sense, Low	J
4	Current Sense, High	G

Dual HBA's - General Description

Paralleling Two HBA's

Two versions of HBA's, **HBA400-28-CAN-DUAL** and **HBA500-28-CAN-DUAL**, have been developed to load share when the outputs are connected in parallel. Two HBA400-28-CAN-DUAL HBA's connected in parallel provide 500A of 28V charging current and two HBA500-28-CAN-DUAL HBA's connected in parallel provide 600A of 28V charging current.

When connected in parallel, one unit is designated as the "Primary" (Master) unit and the other as "Secondary" (Slave) by installing external jumpers in the circular I/O connector. To designate a unit as the Primary, install a jumper between pins "M" and "N". To designate a unit as the Secondary, install a jumper between pins "A" and "N". (See wiring diagram on next page.)

The two units communicate with each other via the vehicle CAN network with the Primary unit providing voltage and control loop logic information for the Secondary unit. Any imbalances introduced to the system, i.e. rapid load changes, are automatically compensated for to ensure equal load sharing.

System Response to Vann-Bus Dynamic Voltage Regulation

If the 28V batteries are in a discharged state, the output voltage of the Primary unit will increase to a value prescribed by the battery monitoring software. Since its reference voltage will be higher than the Secondary unit, it will provide the majority of the load. The Primary unit will request a higher output voltage from the Secondary unit causing its output voltage to increase at a rate of 10mV/s. Once the voltage differential between the two units is approximately $\leq 0.5V$, the Secondary unit will begin to provide more current. Once the voltage differential is approximately $\leq 0.1V$, the units will load share evenly.

After the batteries reach a quiescent state, the output voltage of the Primary unit will reduce to a value prescribed by the battery monitoring software. Since the reference voltage of the Secondary will be higher, it will provide the majority of the current. The output voltage of the Secondary unit will begin to reduce at a rate of 10mV/s. Once the voltage differential is approximately $\leq 0.1V$, the units will load share evenly.

Note: The maximum and minimum output voltages of the HBA's can be set via Vanner's Dashboard Interface Software.

System Response to a Failed Converter, Fault Condition or Loss of +24V Enable Signal

If either unit shuts down due to a failure, fault condition or loss of +24V enable signal, the operational unit will remain on and provide current up to 250A or 300A. If the load is above 250A or 300A, the operational unit will begin current limiting and gradually reduce the output voltage. Once the HBA output voltage decreases to a value less than or equal to the battery voltage, the batteries will begin to assist in supporting the load. If the load continues to increase and the output voltage drops to 20V, the current will begin to fold back. If the output voltage is reduced to 16V, the HBA will turn off.

If certain fault conditions clear or the +24V enable signal is restored, the HBA will restart automatically.

Note: Some fault conditions, once cleared, require cycling the ignition/+24V enable signal before the HBA will restart.

System Response to Loss of CAN Communication

If either unit loses CAN communication both will continue to run, however, their voltage and current loop controls will function independently of each other. Once CAN communication is restored, voltage and control loop controls will be maintained by the Primary unit.

Paralleling Two HBA's Cont'd

The Vanner Dashboard software permits viewing the operational status of both HBA's in a dual application. See screenshots below and display definitions.

Screenshot of Primary HBA Dashboard in a dual application with battery management "ON"

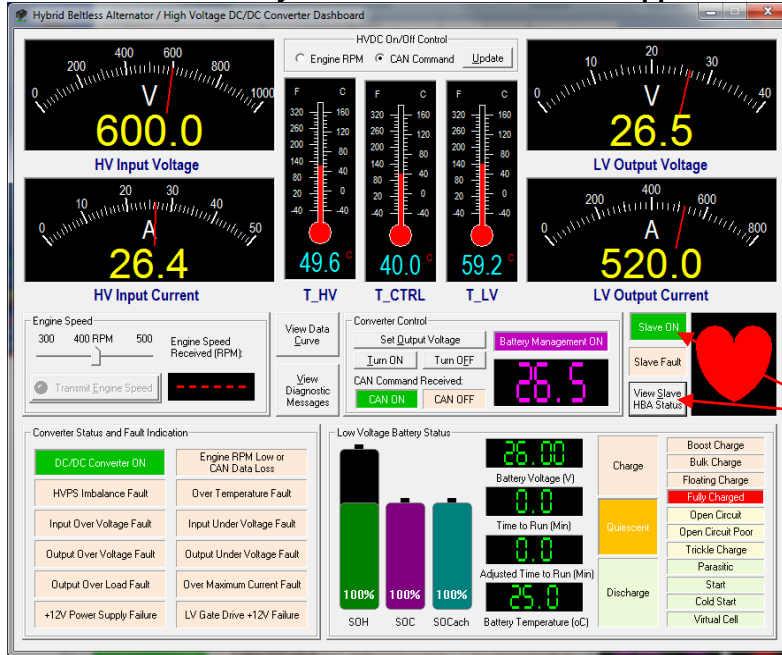

Note that the output voltage is reduced since the 24V batteries are in a "Quiescent" state.

The LV Output Current displayed here is the sum of the "Primary" and "Secondary" HBA's.

"Secondary" unit status. Select the "View Slave HBA Status" icon to open the secondary unit dashboard.

Screenshot of Secondary HBA Dashboard in a dual application

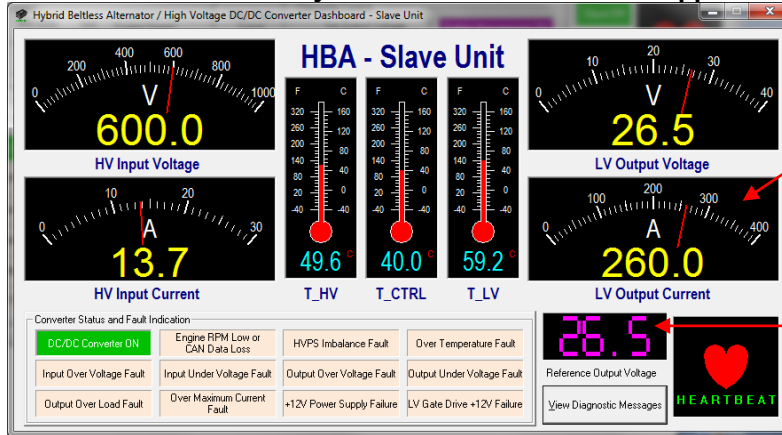

Low voltage output current of "Secondary" HBA. Note that it is 1/2 of total current indicating equal load sharing.

The voltage displayed here is the value the "Primary" unit is requesting from the "Secondary" unit.

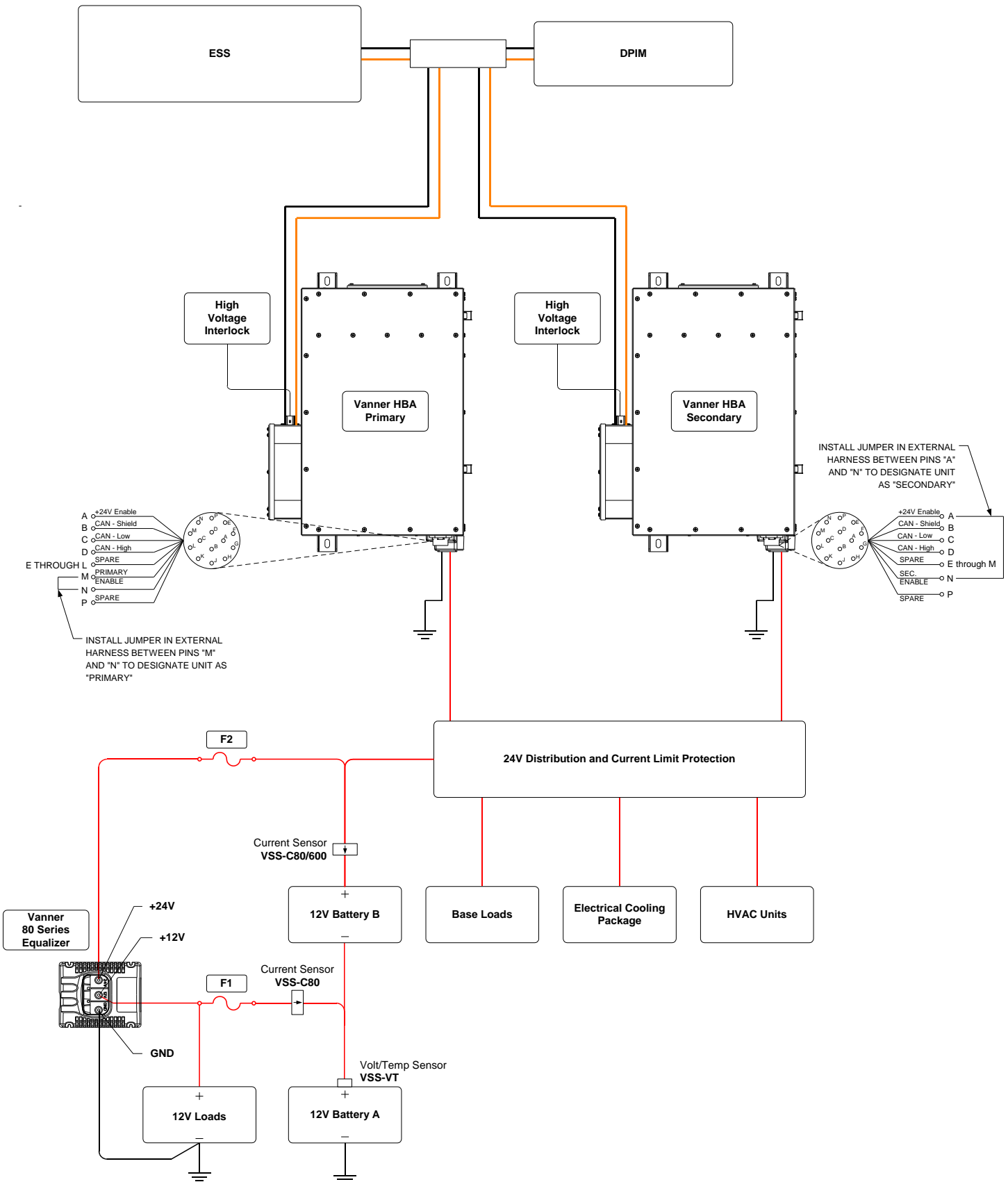

CAN Bus Specification

High Voltage DC/DC Converter CAN Communication Specification

A comprehensive CAN communication specification is available for the HBA. Please contact Vanner's engineering department to ensure you have the latest revision.

**Vanner Incorporated
4282 Reynolds Drive
Hilliard, Ohio 43026**

**1-800-AC POWER
(1-800-227-6937)
Tel: 614-771-2718
Fax: 614-771-4904**

**www.vanner.com
e-mail: pwrsales@vanner.com**

**Part Number D914892-H
January 26, 2018
Printed in U.S.A.**