

User Manual

7603



Read and understand the contents of this User Manual. It contains important safety, handling, and operational instructions for the BatteryLink® Chargers. This User Manual describes the product mentioned herein at the time of its publication. Specifications and performance are subject to change at the discretion of Blue Sea Systems. To view the most current revision of this publication visit blueseasystems.com/products/7603.

IMPORTANT SAFETY INSTRUCTIONS

1. SAVE THESE INSTRUCTIONS

This manual contains important safety and operating instructions for the BatteryLink® Charger model 7603.

2. **WARNING** ⚠️ **RISK OF EXPLOSIVE GASES.** Working in the vicinity of a lead-acid battery is dangerous. Batteries generate explosive gases during normal battery operation. For this reason it is of the utmost importance that each time before using your charger, you read and follow the instructions provided exactly.
3. To reduce risk of battery explosion, follow these instructions and those marked on the battery.
4. **This appliance can be used by children aged from 8 years and above** and persons with reduced physical, sensory or mental capabilities or lack of experience and knowledge if they have been given supervision or instruction concerning use of the appliance in a safe way and understand the hazards involved.
5. Children should be supervised to ensure they do not play with the appliance.
6. **WARNING** ⚠️ **AVOID SERIOUS INJURY OR DEATH FROM FIRE, EXPLOSION, OR ELECTRICAL SHOCK.** The BatteryLink Charger is intended only for fixed installation by qualified professionals. Improper installation can result in electrical shock, which may cause serious injury or death.
 - a. The BatteryLink® Charger is marked as “ignition protected” for operation in a small craft gasoline engine space. **HOWEVER:** Connection or disconnection of any electrical cables may cause sparks, which could ignite flammable gasses and cause explosion.
 - b. Never connect or disconnect electrical cables when explosive gasses may be present.
 - c. Always disconnect AC power sources before connecting or disconnecting the charger AC cord.
 - d. A circuit breaker or other means for disconnection from the supply mains must be incorporated in the fixed wiring to the charger in accordance with wiring rules.
 - e. The AC supply cord should be protected by a Residual Current Device (RCD) suitable for personal shock protection. Make AC connection in a secure manner that will avoid contact with water.
7. Do not operate charger if it has a damaged cord, has received a sharp blow, been dropped, or otherwise damaged in any way. The supply cord cannot be replaced. If the cord is damaged, the appliance should be scrapped.
8. Use charger for charging only these 12V battery types: Flooded lead-acid, AGM, or TPPL. Do not use your marine battery charger to charge non-rechargeable or dry-cell batteries that are commonly used with home appliances. These batteries may burst and cause injury to persons and damage to property.

9. Be sure area around battery is well ventilated while battery is being charged.
Keep open flames and sparks away from batteries, as these may cause explosion.
10. Make or break DC output cable connections to battery only after making and verifying DC connections on the charger, and disconnecting the AC supply to the charger.
11. Do not make or break electrical connections to batteries while charging or for up to 30 minutes after charging.
12. If a battery switch is installed, ensure battery switch is in the OFF position before making or breaking any connections to the battery. If no battery switch is installed, ensure all accessories are OFF.
13. Charger should be grounded to reduce risk of electric shock. Charger is equipped with an electric cord having an equipment-grounding conductor. The charger should be properly wired and grounded in accordance with all local codes and ordinances.
14. For compliance with electromagnetic compatibility standard EN 55014-1:2006, DC output cables must be a fixed installation using non-extendable connectors such as ring terminals, and with maximum length of 2 meters.

BATTERYLINK® CHARGER OVERVIEW

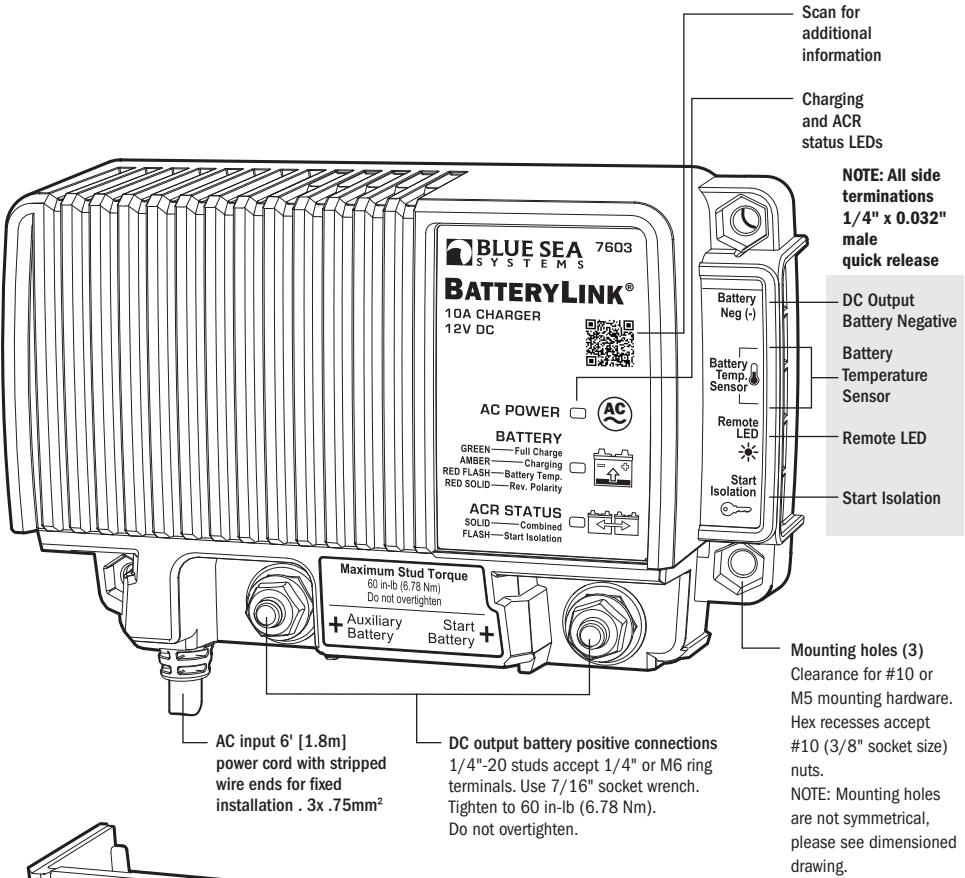

AC input 6' [1.8m] power cord with stripped wire ends for fixed installation . 3x .75mm²

DC output battery positive connections 1/4"-20 studs accept 1/4" or M6 ring terminals. Use 7/16" socket wrench. Tighten to 60 in-lb (6.78 Nm). Do not overtighten.

Mounting holes (3) Clearance for #10 or M5 mounting hardware. Hex recesses accept #10 (3/8" socket size) nuts.
NOTE: Mounting holes are not symmetrical, please see dimensioned drawing.

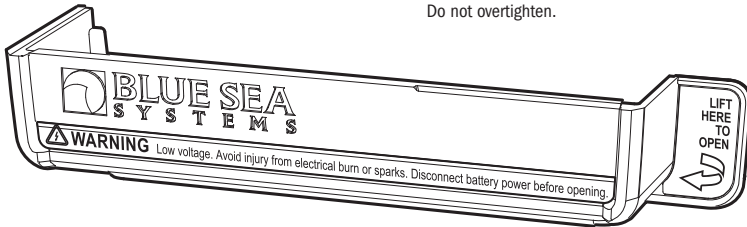

Terminations cover snaps in place to insulate battery positive terminations

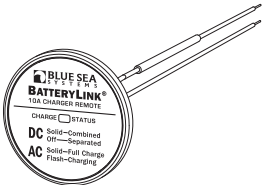

Remote LED included



Battery temperature sensor included

BatteryLink® Charger Features

The BatteryLink® Charger is a 120VAC/230VAC nominal input, 12VDC nominal output, 10A battery charger with integral battery combiner (ACR) providing a second battery connection, as well as standard ACR function when AC power is not present.

- AC power at the dock, provides 10 Amps of charge current
- Integrated ACR automatically combines batteries during charging, isolates batteries when discharging and when starting engines
- Start isolation protects sensitive electronics from voltage sags and spikes
- Battery temperature compensation prolongs battery life
- Supports alternators up to 65 Amps
- One-piece stainless flange nuts ensure safe and secure connections
- Ignition protected—safe for installation aboard gasoline powered boats
- LED light is ON when batteries are combined
- Includes a remote indicator LED with mounting bezel
- Snap-on insulating cover

Automatic Three Stage Charging

The BatteryLink® Charger uses a three stage automatic charging profile. The three stages are referred to as bulk, absorption, and rest/float. The charger will move between these stages automatically, with no user intervention. When the charger starts, it goes first to the bulk stage. This is where the first 75% - 80% of charging takes place. It is a constant current mode, in which the charger outputs as much current as it can to drive the voltage of the battery up to the absorption voltage. Once the absorption voltage is reached, the charger enters absorption mode. This is a constant voltage mode, in which the battery is held at the absorption voltage to complete the last 20% - 25% of charging. In the absorption stage, current will decrease according to the Batteries' needs plus any additional current required for active loads. The length of time spent in the absorption stage will vary based on battery type, battery capacity, and the presence of loads, but will be a minimum of 1 hour up to a maximum of 5 hours. After the absorption stage, the charger will move to the rest/float stage. The float stage is a constant voltage mode intended to maintain fully charged batteries while supplying current for loads as necessary. The rest mode is included as an energy saving mode, and for compliance with California Energy Commission (CEC) requirements. In the rest stage, the charger output and ACR are turned off to conserve energy, and the battery voltages are monitored. If loads or self-discharge on either battery cause the voltage to drop to 12.9V, the charger enters float mode for 4 hours in order to maintain the battery and supply current to loads. After seven days of continuous rest/float mode, the charger will repeat the normal charge cycle to assure good battery health.

Battery Temperature Compensation

Battery temperature compensation is output voltage regulation based on battery temperature variances. Since batteries can see extreme temperature differences, it is important to regulate output voltage with temperature to maximize battery life. A battery in a cold environment should not be charged at the same voltage as a battery in a hot environment. The BatteryLink® Charger is set at a baseline of 25°C. If the included battery temperature sensor is installed, then every 5°C variance from this baseline will result in a change in output voltage. Voltage will decrease at higher temperatures, and increase at lower temperatures. The temperature sensor also allows the charger to react to extreme hot or cold temperatures (below 0°C or above 45°C) by reducing output or shutting down to preserve the battery. Reference the Installation Instructions on page 6 and the Full Installation Diagram on page 8 for details on how to install the battery temperature sensor.

Automatic Charging Relay (ACR)

The BatteryLink® Charger includes an integrated 65A Automatic Charging Relay (ACR). The purpose of an ACR is to combine batteries for charging, but leave them isolated for discharge. This works well with dual battery systems, where non-starting loads are isolated from the engine starting battery to reduce the risk of being stranded on the water without enough power to start your engine. The ACR in the BatteryLink® Charger will combine the auxiliary and start batteries at or away from the dock. This means both batteries will be charged during AC powered charging, or when AC power is not available and a secondary charging source is active, such as your engine's alternator. The ACR includes an optional Start Isolation feature, which can be used to prevent engine starting current being drawn from the auxiliary battery. Start Isolation protects sensitive electronics wired to the auxiliary battery from being affected by voltage sags or spikes caused by engine starting. Reference the Installation Instructions on page 6 and the Full Installation Diagram on page 8 for details on how to wire the Start Isolation feature.

Supplies Needed

- DC Wire: Black or yellow for negative, red for each positive. **NOTE:** All wiring should be of sufficient length to allow proper routing, support, drip loops, service loops, and termination.
- Fuse holders for connection to each battery, for charger negative, and for optional Start Isolation and Remote LED wiring if used (see Full Installation Diagram, page 8).
- Fuses for fuse holders (see table below and Full Installation Diagram, page 8).
- Screwdriver: Phillips #2 for mounting screws.
- Socket wrench (torque wrench preferred): 7/16" socket for DC battery positive connections. Other socket sizes as needed for connection to battery and fuse holder terminals.
- Terminals: 1/4" or M6 ring terminals for charger side DC battery positive connections. 1/4" x 0.032" female quick disconnect terminals for DC battery negative and accessory connections. Other ring terminals sized for connection to battery and fuse holder terminals.
- Appropriately sized butt connectors for extending remote LED and battery temperature sensor wires.
- Appropriate terminals for connection of 0.75mm² AC supply wires to AC source.
- Crimping tool or obtain wires that are pre-terminated.
- Appropriate heat shrink if pre-terminated wires were not acquired.
- 5A circuit breaker recommended for connection to AC supply panel

Wire Size and Fuse Rating Table*

Conductor Length in feet (meters)		Positive Wire (sized for maximum alternator output)			Negative Wire (sized for 10A charger output)
		Alternator up to 30A	Alternator up to 50A	Alternator up to 65A	
6 ft (1.83 meters)		10 AWG (6 mm ²)	6 AWG (16 mm ²)	6 AWG (16 mm ²)	14 AWG (2.5 mm ²)
10 ft (3.05 meters)		6 AWG (16 mm ²)	4 AWG (25mm ²)	4 AWG (25mm ²)	12 AWG (4 mm ²)
15 ft (4.57 meters)		6 AWG (16 mm ²)	2 AWG (35 mm ²)	2 AWG (35 mm ²)	10 AWG (6 mm ²)
20 ft (6.09 meters)		4 AWG (25mm ²)	2 AWG (35 mm ²)	1 AWG (50 mm ²)	8 AWG (10 mm ²) **
25 ft (7.62 meters)		2 AWG (35 mm ²)	1 AWG (50 mm ²)	1/0 AWG (70 mm ²)	8 AWG (10 mm ²) **
Recommended Fuse Rating ***		40A	60A	90A-100A	30A (see next row)
Fuse Required For Negative?		YES, if negative wire is < 12 AWG (4 mm ²)	YES, if negative wire is < 8 AWG (10 mm ²)	YES	-
Fuse Type	Fuse Holder PN	Recommended Blue Sea Systems Fuse PN			
MRBF Fuse	5191	5176 (40A)	5178 (60A)	5182 (90A)	Not Recommended
AMI®/MIDI® Fuse	7720	5251 (40A)	5253 (60A)	5256 (100A)	5250 (30A)
ATO®/ATC® Fuse	5065	Not Recommended	Not Recommended	Not Recommended	5245 (30A)

* Based on 3% voltage drop. If fast charge recovery is important, use larger wire.

** If marine grade 8 AWG (10 mm²) 1/4" quick connect terminals are not readily available, it is recommended to make a short 10 AWG (6 mm²) jumper to a terminal block or PowerPost, and then continue from that point with 8 AWG (10 mm²) cable.

*** Fuses in positive wires should be located as close as possible to the battery positive terminal. If required, the fuse in the negative wire should be located as close as possible to the charger.

For more information please use the Circuit Wizard at circuitwizard.bluesea.com

LED Status Indicators

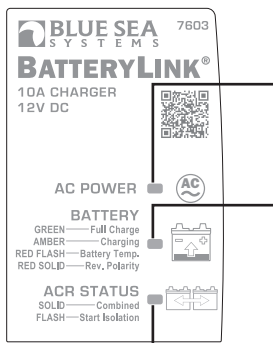

Name		States	
AC POWER	Green solid	AC power present	
	Off	No AC power	
BATTERY	Green solid	Charging complete - Float/rest stage	
	Amber solid	Charging in progress - Bulk or absorption stage	
	Red single blink	Battery hot - Charger shutdown (>=50°C)	
	Red double blink	Battery hot - Output reduction (>=45°C and <50°C)	
	Red triple blink	Battery cold - Charger shutdown (<= 0°C)	
	Red solid	Battery polarity reversed	
ACR STATUS	Off	No AC power	
	Green solid	Combined - ACR closed	
	Double-blink	SI present - ACR open	
	Off	Battery voltages below threshold - ACR open	
REMOTE LED CHARGE STATUS	DC Power	Solid	Combined - ACR closed
		Off	Separated - ACR open
	AC Power	Solid	Charging complete - Float/rest stage
		Flash	Charging in progress - Bulk or absorption stage

INSTALLATION INSTRUCTIONS

1. Before beginning electrical installation, disconnect all positive and negative AC and DC power sources.

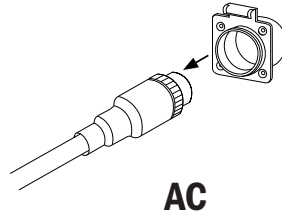
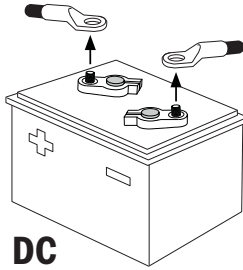

2. For optimal performance, mount the charger vertically, in a well ventilated location.
NOTE: The charger should be located near the batteries to minimize wire length and its associated voltage drop to maximize charging efficiency. If the batteries are not close together, place the charger near the battery connected to the Start Battery stud. All DC charging sources must be attached to the Start Battery (ie. alternator or solar panel)
3. Remove the DC termination cover by lifting the tab on the right hand side.
4. Route DC wires from each charger output to battery fuse holder. See Installation Diagrams on pages 7 and 8. All wiring should be of sufficient length to allow proper routing, support, drip loops, service loops, and termination. Strain relief for wiring should be installed near the charger to prevent loosening of connections with vibration or shock. Fuses should be installed at the battery positive connections to prevent battery power from feeding back into a fault in the wiring, or in the battery charger. See Wire Size And Fuse Rating Table on page 5 for recommended fuse values. Best practices dictate that every positive wire on the boat, outside the engine starting circuit, must have circuit protection. Please follow all local and national electrical standards, codes, and regulations for installation and wiring.
5. Route the AC supply cord from the charger to the AC panel, and terminate at the appropriate AC circuit breaker. Leave the breaker in the "off" position.
NOTE: Connect AC wiring, but do not energize the circuit until AC wiring is properly covered, DC is connected, and DC fuses are installed.
6. Recommended Connection [Battery Temperature Sensor]: Attach the battery temperature sensor to the largest battery using the supplied adhesive pad. If both batteries are the same size, attach to the battery with the most loads. Attach the sensor in the center of the long side of the battery. If multiple batteries are in a battery bank, attach the sensor in the center between multiple batteries. When external circumstances could create a significant difference in temperature on one side of a battery versus another, always attach the sensor on the warmest side. NEVER pierce the battery casing with a screw or other fastener. Extend sensor wires as necessary to reach the charger using appropriate fully insulated butt connectors or a terminal block with insulating cover.
7. Optional Installation [Remote LED Bezel]: Drill a 7/16" [11mm] hole through a flat mounting surface in a visible location. Clean and dry the surface around the drilled hole for best adhesion of the bezel. Remove the adhesive backing liner from the bezel, thread the LED wires through the hole, and push the bezel securely into place against the mounting surface. Extend the LED wires as necessary using appropriate fully insulated butt connectors or a terminal block with insulating cover. Connect the positive (red) wire from the LED to your battery positive terminal through a 2A fuse at the battery. Place this connection on top of all current carrying conductors. Connect the negative (yellow) wire from the LED to the charger Remote LED terminal.
8. Optional Connection [Start Isolation-protects sensitive electronics from voltage drops and spikes during engine start]: Connect the Start Isolation terminal of the charger to the "start" position of your engine's ignition switch, or another connection point that has positive voltage applied only when actively cranking your engine. Install a 2A fuse at the point of connection to positive voltage.
9. Install appropriate DC fuses (see Wire Size And Fuse Rating Table on page 5).
10. Confirm all connections are correctly installed per Installation Diagrams.
11. Secure the termination cover back over the connected wires.
12. Restore AC power and turn on the AC supply circuit breaker to the battery charger.

QUICK INSTALLATION DIAGRAM

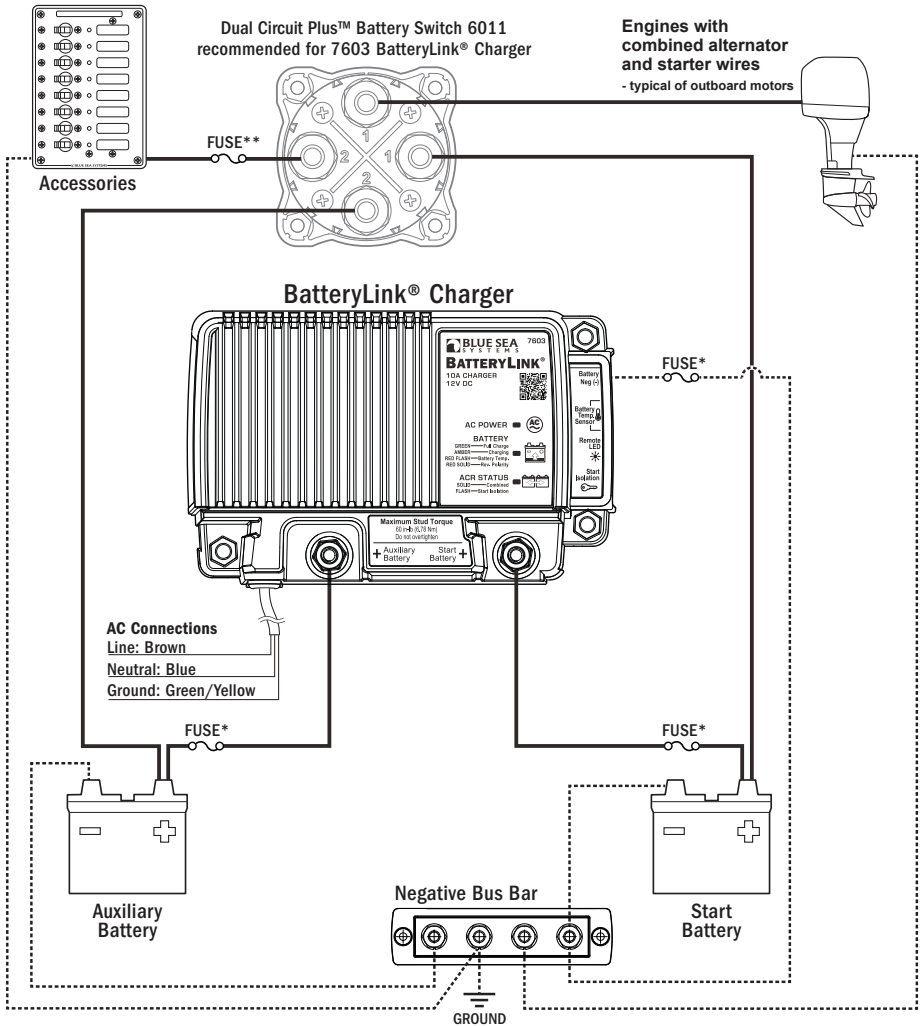

Legend

DC Negative ----- DC Positive ————

* See Wire Size and Fuse Rating Table, page 5.

** Wire size and fuse rating based on house loads. For more information, use the Circuit Wizard at circuitwizard.bluesea.com.

FULL INSTALLATION DIAGRAM

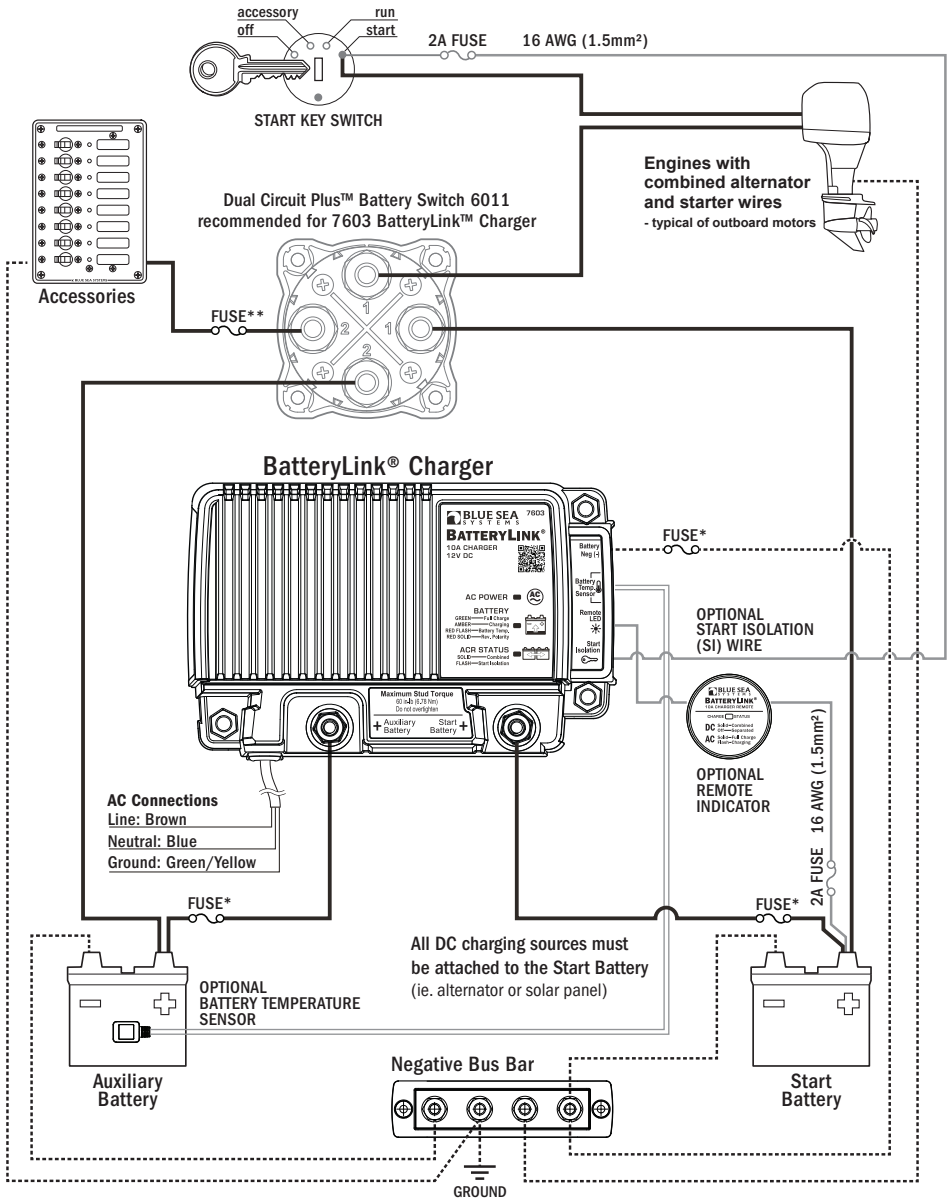

Legend

DC Negative ----- Optional ———— DC Positive ————

* See Wire Size and Fuse Rating Table, page 5.

** Wire size and fuse rating based on house loads. For more information, use the Circuit Wizard at circuitwizard.bluesea.com.

Specifications

Nominal Output Voltage	12V DC
Total Output Current (0-25°C)	10A
Total Output Current (0-50°C)	9A
Output Connections	2 positive, 1 negative
Universal AC Input Voltage	100V-240V AC
Input Frequency Range	50/60 Hz
AC Input Current	3.25A @ 100V 1.75A @ 200V
Typical Float Voltage (25°C)	13.5V DC
Typical Absorption Voltage (25°C)	14.4V DC
Battery Temperature Compensation Coefficient	-30 mV/°C
ACR Continuous Rating	65A
ACR Continuous Rating (during AC charging)	40A
ACR Intermittent Rating (5 min.)	115A
ACR Combine Voltage	13.0V (2 min.) 13.5V (30 sec.) 12.35V (10 sec.) 12.75V (30 sec.)
ACR Open Voltage	10mA (ACR open) 60mA (ACR closed)
Operating Current (no AC power)	1/0 AWG (50mm ²)
Maximum Cable Size	1/4"-20 (accepts M6 ring terminal)
Terminal Stud Size	60 in-lb (6.8 Nm)
Maximum Terminal Stud Torque	1/4" x 0.032"
Quick Connect Terminal Size	0°C - 50°C
Operating Temperature Range	-30°C - 80°C
Storage Temperature Range	5 Year
Warranty	Flooded, AGM, TPPL
Battery Types	6 cells
Battery Number of Cells	850 CCA
Maximum Battery CCA	120Ah (20 hour rate)
Maximum Battery Capacity	

Regulatory

Designed and constructed for compliance to EN 60335-2-29

Ignition protection per ISO 8846, and SAE J1171

IP67 - protected against immersion up to 1 meter for 30 minutes



DIMENSIONED DRAWINGS

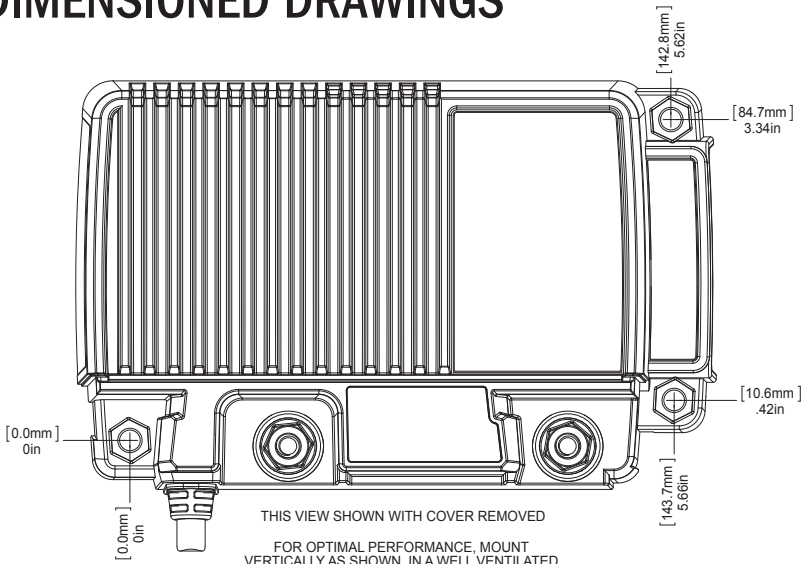

FOR OPTIMAL PERFORMANCE, MOUNT VERTICALLY AS SHOWN, IN A WELL VENTILATED AREA. RECOMMENDED MOUNTING CLEARANCE 50mm MINIMUM ON ALL SIDES.

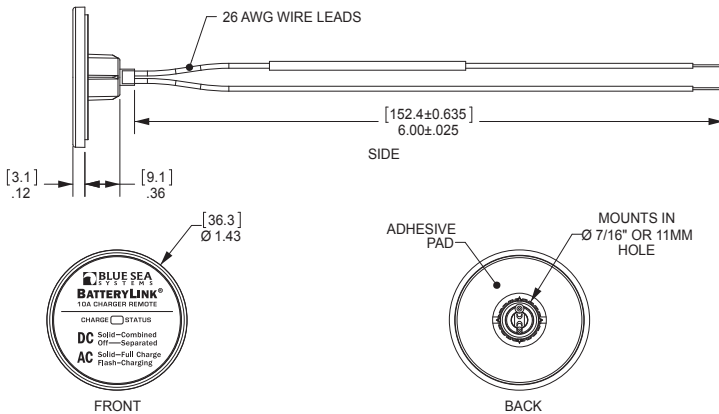
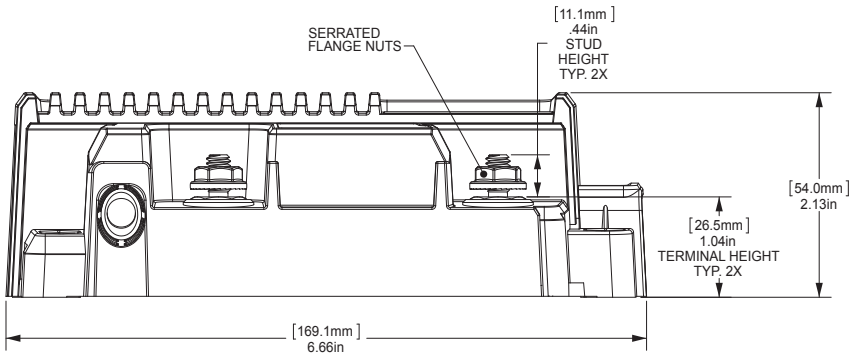

EC DECLARATION OF CONFORMITY

For the following equipment:

Product type: Battery charger

Type designation: BatteryLink Charger: 7603, 7604

Manufacturer: Blue Sea Systems, Inc.

Address: 425 Sequoia Drive
Bellingham, WA
98226 USA
Phone: 001.360.738.8230



Herewith it is confirmed to comply with the requirements set out in the council directive, 2006/95/EC for electrical equipment used within certain voltage limits, the EMC directive 2004/108/EC, and the Recreational Craft Directive 2013/53/EU.

Safety: IEC60335-1:2010+A1
IEC60335-2-29:2002+A1+A2
EN60335-1:2010+A1
EN60335-2-29:2002+A1+A2

EMC: **Emission:** EN 55014-1:2006/A1:209, /A2:2011
Radiated emission
Conducted emission
EN61000-3-2 Harmonics
EN61000-3-3 Voltage fluctuations and flicker
Immunity: EN 55014-2:1997/A1:2002, /A2:2008
EN61000-4-2 Electrostatic discharge
EN61000-4-3 RF electromagnetic field
EN61000-4-4 Fast transient
EN61000-4-5 Surges
EN61000-4-6 RF conducted disturbances
EN61000-4-11 Voltage dips and interruptions

Ignition Protection:

ISO 8846 (ed. 1)

The notified body HPI Verification Services Ltd (NB 1521) performed type examination to verify compliance with the above ignition protection standard, and issued the certificate HPIVS/R1168-001-I-01.

The undersigned hereby declare that the equipment specified above conforms to the above directives and standards

Bellingham 2016-04-1
Blue Sea Systems, Inc.

A handwritten signature in black ink, appearing to read 'David Johnson', written over a dotted line.

David Johnson, Senior Vice President of Marine and Mobile



conductor@blueseas.com
www.blueseas.com