



MagnaSine Hybrid – Renewable Energy Series Pure Sine Wave Inverter/Charger



MSH-RE Series Owner's Manual



Disclaimer of Liability

The use of this manual and the conditions or methods of installation, operation, use and maintenance of the MSH-RE Series inverter/charger is beyond the control of Magnum Energy, Inc. Therefore, this company does not assume responsibility and expressly disclaims liability for loss, damage, or expense whether direct, indirect, consequential or incidental that may arise out of or be any way connected with such installation, operation, use, or maintenance.

Due to continuous improvements and product updates, the images shown in this manual may not exactly match the unit purchased.

Restrictions on Use

The MSH-RE Series inverter/charger may only be used in life support devices and systems with the express written approval of Magnum Energy. Failure of this inverter can reasonably be expected to cause failure of that life support device or system, or to affect the safety or effectiveness of that device or system. If the MSH-RE Series inverter fails, it is reasonable to assume the health of the user or other persons may be endangered.

Copyright Notice

Copyright © 2013 by Magnum Energy, Inc. All rights reserved. Permission to copy, distribute, and/or modify this document is prohibited without express written permission from Magnum Energy, Inc.

Document Information

Description – MSH-RE Series Owner’s Manual
Part Number and Revision – 64-0059 Rev A
Date Published – May 2013

This manual is printed without color for cost savings. However, this entire manual is available for download—with many of the figures available in color—under the Document Library tab at www.MagnumEnergy.com.

Contact Information

Magnum Energy, Inc.
2211 West Casino Rd.
Everett, WA 98204
Phone: 425-353-8833
Fax: 425-353-8390
Web: www.MagnumEnergy.com

Statement of Appreciation

Thank you from all of us at Magnum Energy for purchasing this MSH-RE Series inverter/charger. We understand that you have many purchasing options in the marketplace, and are pleased that you have decided on a Magnum Energy product. This MSH-RE Series inverter/charger was proudly assembled and tested in the United States in our Everett, Washington, facility.

At Magnum, we are committed to providing you with quality products and services, and hope that your experience with us is pleasant and professional.

Record unit's model & serial number in case you need to provide this information in the future.	
Model:	Serial Number:
<input type="checkbox"/> MSH4024RE	AR

Magnum Energy® is a registered trademark of Magnum Energy, Inc.

IMPORTANT SAFETY INSTRUCTIONS

SAVE THESE INSTRUCTIONS

THIS MANUAL CONTAINS IMPORTANT INSTRUCTIONS FOR THE MSH-RE SERIES INVERTER/CHARGER THAT SHALL BE FOLLOWED DURING THE INSTALLATION AND OPERATION OF THIS PRODUCT. Before using the MSH-RE Series, read all instructions and cautionary markings. Also, be sure to review the individual manuals provided for each component of the system. The installation instructions are for use by qualified personnel only. Do not perform any installation or servicing other than that specified in this owner's manual unless you are qualified to do so. Incorrect installation or servicing may result in a risk of electric shock, fire, or other safety hazard.

Safety Symbols

The following safety symbols have been placed throughout this manual to indicate dangerous and important safety instructions.



WARNING: This symbol indicates that failure to take a specified action could result in physical harm to the user.



CAUTION: This symbol indicates that failure to take a specified action could result in damage to the equipment.



Info: This symbol indicates information that emphasizes or supplements important points of the main text.

Safety Precautions

- All electrical work must be performed in accordance with local and national electrical codes.
- This product is designed for indoor/compartment installation. It must not be exposed to rain, snow, moisture, or liquids of any type.
- Use insulated tools to reduce the chance of electrical shock or accidental short circuits.
- There are no user-serviceable parts contained in this product.
- This unit is provided with integral protection against overloads.
- Live power may be present at more than one point since an inverter utilizes both DC (batteries, PV, etc.,) and AC (utility or generator) power. To reduce risk of electric shock, ensure all DC and AC wiring is disconnected prior to installing or performing maintenance on the inverter. Turning off the inverter will not reduce this risk, the inverter must be totally disconnected from all sources.
- Use Class 1 wiring methods for field wiring connections to terminals of a Class 2 circuit.
- Listed or labeled equipment shall be installed and used in accordance with any instructions included in the listing or labeling.
- Always verify proper wiring prior to starting the inverter.
- Use only copper wires with a minimum temperature rating of 75°C.
- AC wiring must be no less than #6 AWG (13.3 mm²) gauge copper wire.
- Battery cables should be no less than #4/0 AWG (107.2 mm²) for 12 and 24-volt systems. Crimped and sealed copper ring terminal lugs with a 5/16 hole should be used to connect to the DC terminals on the inverter.
- Torque all AC wiring connections and DC cable connections to the required torque values.
- The inverter must be properly mounted, see Section 2.2 "Mounting the Inverter" in this manual.
- Overcurrent protection for the battery supply is not provided as an integral part of this inverter. Overcurrent protection of the battery cables must be provided as part of the system installation. Refer to Section 2.4 "DC Wiring" for more information.

Safety Information

- Overcurrent protection for the AC output wiring is not provided as an integral part of this inverter. Overcurrent protection of the AC output wiring must be provided as part of the system installation. Refer to Section 2.5 "AC Wiring" for more information. **Note:** *An output breaker is provided on the inverter to provide overcurrent protection to the inverter's internal wires; however, this output breaker is not rated to protect the AC output wiring.*
- The AC output neutral conductor and the DC negative conductors are not connected (bonded) to the inverter chassis. Both the input and output conductors are isolated from the enclosure and each other. System grounding, if required, is the responsibility of the system installer and must comply with local and national electrical codes and standards. Refer to the Section 2.6 "Grounding Inverters" for more information.

Battery Safety

- Use insulated tools and be very careful when working around batteries, they can produce extremely high currents if short-circuited (e.g., dropping a metal tool across the battery terminal), which could cause a fire or explosion.
- Read and follow the battery manufacturer's safety precautions before installing the inverter and batteries. Always verify proper polarity and voltage before connecting the batteries to the inverter. Once the batteries are connected to the inverter, ensure the maintenance and charging requirements (i.e., charge voltage and charge rate) provided by the battery manufacturer are followed to extend the life of the batteries and to prevent damage to the batteries while charging.
- Wear eye protection such as safety glasses, and avoid touching your eyes and face when working with batteries to keep any fluid/corrosion on the battery from coming in contact with eyes and skin. Have plenty of fresh water and soap nearby and thoroughly wash in case battery acid contacts skin, clothing, or eyes. In the event of exposure to the eyes, flood them for at least 15 minutes with running water and seek immediate medical attention. Baking soda neutralizes lead acid battery electrolyte and vinegar neutralizes spilled NiCad and NiFe battery electrolyte; depending on your battery type, keep a supply on hand near the batteries.
- Remove all jewelry such as rings, watches, bracelets, etc., when installing or performing maintenance on the batteries and inverter. A battery can produce a short-circuit current high enough to weld metal jewelry, causing severe burns.
- Never work alone. Always have someone within the range of your voice or close enough to come to your aid when working around batteries.
- Use proper lifting techniques when working with batteries.
- Never use old or untested batteries. Check each battery's label for age, type, and date code to ensure all batteries are identical.
- Batteries sensitive to changes in temperature. Always install in a stable environment.
- Batteries can produce explosive gasses, so install batteries in a well-ventilated area. For compartment or enclosure installations, always vent batteries from the highest point to the outside. Design the battery enclosure to prevent accumulation and concentration of hydrogen gas in pockets at the top of the compartment.
- Provide at least one inch of air space between batteries to provide optimum cooling.
- Never smoke or allow a spark near batteries.
- To prevent a spark at the battery and reduce the chance of explosion, always connect the cables to the batteries first. Then connect the cables to the inverter.
- Never charge a frozen battery.
- The battery bank should be installed in a clean, dry, ventilated environment where they are protected from high and low temperatures. The location must be fully accessible and protected from exposure to heat producing devices, and away from any fuel tanks.

CONSIGNES DE SÉCURITÉ IMPORTANTES

CONSERVER CES INSTRUCTIONS

CE MANUEL CONTIENT DE IMPORTANTES POUR LA SÉRIE MSH-RE ONDULEUR/CHARGEUR QUI DOIVENT ÊTRE SUIVIES PENDANT L'INSTALLATION ET FONCTIONNEMENT DE CE PRODUIT. Avant d'utiliser la série MSH-RE, lire toutes les instructions et les mises en garde. Aussi, n'oubliez pas de passer en revue les différents manuels fournis pour chaque composant du système. Les instructions d'installation sont pour une utilisation par du personnel qualifié. Ne pas effectuer une installation ou d'entretien autres que ceux spécifiés dans ce manuel, sauf si vous êtes qualifié pour le faire. Une mauvaise installation ou d'entretien peut entraîner un risque de choc électrique, un incendie ou autre danger pour la sécurité.

Symboles de sécurité

Les symboles de sécurité suivants ont été placés tout au long de ce manuel pour indiquer des conditions dangereuses et les consignes de sécurité importantes.



AVERTISSEMENT: Ce symbole indique que le défaut de prendre une action spécifiée pourrait causer des dommages physiques à l'utilisateur.



ATTENTION: Ce symbole indique que le défaut de prendre une action spécifiée peut entraîner des dommages à l'équipement.



Info: Ce symbole indique une information qui met l'accent ou des suppléments points importants du texte principal.

Consignes de sécurité

- Tous les travaux électriques doivent être effectués en conformité avec les codes locaux et nationaux électriques.
- Ce produit est conçu pour l'installation / du compartiment intérieur. Il ne doit pas être exposé à la pluie, la neige, l'humidité ou des liquides de tout type.
- Utiliser des outils isolés pour réduire le risque de choc électrique ou courts-circuits accidentels.
- Il n'y a pas réparable par l'utilisateur contenues dans ce produit.
- Cet appareil est fourni avec une protection intégrale contre les surcharges.
- Puissance en direct peuvent être présents à plus d'un point depuis un onduleur utilise à la fois DC (piles, PV, etc.,) et AC (utilitaire ou générateur) d'alimentation. Pour réduire le risque de choc électrique, assurez-vous que tout le câblage DC et AC est débranchée avant l'installation ou la maintenance sur le variateur. Mise hors tension de l'onduleur ne réduira pas ce risque, l'onduleur doit être totalement déconnectée de toutes les sources.
- Utiliser des méthodes de câblage Classe 1 pour les connexions de câblage sur le terrain aux bornes d'un circuit de Classe 2.
- Coté ou étiquetés équipement doit être installé et utilisé conformément aux instructions figurant dans la liste ou l'étiquetage.
- Toujours vérifier le câblage avant de commencer l'onduleur.
- Utilisez des fils de cuivre seulement avec une cote de température minimale de 75° C.
- AC câblage ne doit pas être inférieure à #6 AWG (13.3 mm²) de cuivre de calibre.
- Les câbles de batterie ne doit pas être inférieur à # 4/0 AWG (107.2 mm²) pour 24-volts systèmes. Frisées et scellé cosses en cuivre anneau des bornes avec un trou de 5/16 doit être utilisé pour se connecter à des bornes de courant continu sur l'onduleur.
- Couple toutes les connexions de câblage ca et les connexions de câbles à courant continu à des valeurs de couple nécessaires.
- L'onduleur doit être correctement monté, voir le montage de la section onduleur dans le chapitre Installation de ce manuel.
- Protection contre les surintensités pour l'alimentation de la batterie n'est pas fourni en tant que partie intégrante de cet inverseur. La protection contre les surintensités des câbles de batterie doivent être fournis dans le cadre de l'installation du système. Reportez-vous à la Section Câblage cc dans le chapitre d'installation pour plus d'informations.

Safety Information

- Protection contre les surintensités pour le câblage de sortie AC n'est pas fourni en tant que partie intégrante de cet onduleur. Protection contre les surintensités du câblage de sortie CA doit être fournie dans le cadre de l'installation du système. Reportez-vous à la Section 2.5 Câblage ca dans le chapitre d'installation pour plus d'informations. **Remarque:** Un disjoncteur de sortie est prévue sur le convertisseur pour fournir une protection contre les surintensités de fils internes de l'onduleur, mais ce disjoncteur de sortie n'est pas évalué pour protéger le câblage de sortie CA.
- Le conducteur de sortie CA conducteurs neutre et continue négative ne sont pas connectés (servitude) au châssis inverseur. La fois l'entrée et des conducteurs de sortie sont isolés de l'enceinte et l'autre. La terre du système, si nécessaire, est de la responsabilité de l'installateur du système et doit se conformer à des codes locaux et nationaux et les normes électriques. Reportez-vous à la Section 2.6 Mise à la terre Onduleurs dans le chapitre d'installation pour plus d'informations.

Sécurité de la batterie

- Utiliser des outils isolés et être très prudent lorsque vous travaillez près des batteries, elles peuvent produire des courants extrêmement élevés si en court-circuit (par exemple, échapper un outil métallique à travers la borne de la batterie), ce qui pourrait provoquer un incendie ou une explosion.
- Lisez et suivez les consignes de sécurité du fabricant de la batterie avant d'installer l'onduleur et des batteries. Toujours vérifier la polarité et la tension avant de brancher les batteries à l'onduleur. Une fois que les batteries sont connectées à l'onduleur, assurer la maintenance et les exigences de charge (c.-à-tension de charge et taux de charge) fournis par le fabricant de la batterie sont suivies pour prolonger la vie des batteries et pour éviter d'endommager les batteries pendant la charge.
- Porter des lunettes de protection tels que des lunettes de sécurité, et évitez de toucher vos yeux et le visage lorsque l'on travaille avec des piles de garder tout fluide / corrosion sur la batterie d'entrer en contact avec les yeux et la peau. Ayez suffisamment d'eau fraîche et de savon à proximité et se laver dans le cas d'acide contact avec la peau de la batterie, les vêtements ou les yeux. Dans le cas d'exposition pour les yeux, les inonder pendant au moins 15 minutes à l'eau courante et consulter immédiatement un médecin. Le bicarbonate de soude neutralise l'acide de plomb électrolyte de la batterie et le vinaigre neutralise renversé NiCad et NiFe batterie à électrolyte; en fonction de votre type de batterie, gardez sous la main près des batteries.
- Enlevez tous les bijoux tels que bagues, montres, bracelets, etc, lors de l'installation ou la maintenance sur les batteries et l'onduleur. Une batterie peut produire un court-circuit assez de courant élevé pour souder les bijoux en métal, provoquant de graves brûlures.
- Ne jamais travailler seul. Toujours avoir quelqu'un au sein de la gamme de votre voix ou suffisamment près pour vous venir en aide lorsque vous travaillez près des batteries.
- Utiliser des techniques de levage appropriées lorsque vous travaillez avec des piles.
- Ne jamais utiliser de piles usagées ou non testés. Vérifiez l'étiquette de chaque batterie à l'âge, le type et le code de date afin d'assurer toutes les batteries sont identiques.
- Batteries sensibles aux changements de température. Toujours installer dans un environnement stable.
- Les batteries peuvent produire des gaz explosifs, etc installer les piles dans un endroit bien ventilé. Pour les installations compartiment ou une enceinte, toujours évacuer les piles du plus haut point à l'extérieur. Concevoir le boîtier de piles pour éviter l'accumulation et la concentration de gaz d'hydrogène dans "poches" en haut du compartiment.
- Fournir au moins un pouce de l'espace aérien entre les batteries pour fournir un refroidissement optimal.
- Ne jamais fumer ou laisser une étincelle près des batteries.
- Pour éviter une étincelle à la batterie et de réduire le risque d'explosion, toujours connecter les câbles aux batteries en premier. Ensuite, connectez les câbles à l'onduleur.
- Ne jamais charger une batterie gelée.
- La banque de la batterie doit être installé dans un endroit propre, sec, aéré et où ils sont protégés contre les températures élevées et basses. L'emplacement doit être pleinement accessible et protégé contre l'exposition à la chaleur la fabrication de dispositifs, et loin de toute réservoirs de carburant.

Table of Contents

1.0	Introduction	1
1.1	How an Inverter/Charger Works	2
1.2	Advantages of using a Pure Sine Wave Inverter	2
1.3	Features and Benefits	3
2.0	Installation	6
2.1	Pre-Installation	6
2.2	Mounting the Inverter	9
2.3	Wiring the Inverter – General Requirements	11
2.4	DC Wiring	12
2.5	AC Wiring	19
2.6	Grounding Inverters	23
2.7	Inverter Notification Requirements	27
2.8	Final Inspection	28
2.9	Functional Test	29
3.0	Operation	30
3.1	Inverter Mode	30
3.2	Standby Mode	31
3.3	Current Flow	34
3.4	Transfer Time	36
3.5	Battery Temperature Sensor Operation	36
3.6	Protection Circuitry Operation	37
3.7	Inverter Startup	38
3.8	Factory Default Values	39
3.9	Inverter Fan Operation	40
3.10	Using a Remote with the MSH-RE Series Inverter	40
4.0	Maintenance and Troubleshooting	41
4.1	Recommended Inverter and Battery Care	41
4.2	Troubleshooting	42
4.3	Performing an Inverter Reset	43
4.4	Performing a Power Reset	43
	Appendix A – Specifications and Optional Equipment	44
A-1	Inverter/Charger Specifications	44
A-2	Performance Graphs	45
A-3	Optional Equipment and Accessories	46
	Appendix B – Battery Information	47
B-1	Battery Location	47
B-2	Battery Types	47
B-3	Battery Temperature	47
B-4	Battery Bank Sizing	47
B-5	Battery Bank Sizing Worksheet	48
B-6	Battery Wiring Configurations	49
	Appendix C – Power Consumption and Output Waveforms	51
C-1	Appliance Power Consumption	51
C-2	Inverter Output Waveforms	51
	Appendix D – Inverter/Charger Terminology	52
	Appendix E – Warranty and Service Information	54
E-1	Limited Warranty	54
E-2	How to Receive Repair Service	55

List of Figures

Figure 1-1, Power Switch, Status LED, and Accessory Connection Ports.....	3
Figure 1-2, Electrical Connection Points	4
Figure 1-3, Left Side Features	5
Figure 2-1, Simplified Installation Diagram.....	7
Figure 2-2, Approved Mounting Positions	9
Figure 2-3, MSH4024RE Dimensions and Side Reference.....	10
Figure 2-4, DC and Battery Temperature Sensor Wiring	13
Figure 2-5, Battery Hardware Installation	15
Figure 2-6, Inverter DC Hardware Installation	15
Figure 2-7, Battery Temperature Sensor	17
Figure 2-8, AC Terminal Block	20
Figure 2-9, AC Wiring.....	22
Figure 2-10, Grounding System for MSH-RE.....	23
Figure 2-11, Multiple Connections to DC Ground Rod (Method 1).....	24
Figure 2-12, Multiple Connections to DC Ground Rod (Method 2).....	25
Figure 2-13, Single Connection to DC Ground Rod (Method 3)	25
Figure 2-14, Large Ground Wire Connected to MSH-RE Series.....	27
Figure 2-15, Warning Label	28
Figure 2-16, AC Voltage Checks.....	29
Figure 3-1, Power Flow – Inverter Mode.....	30
Figure 3-2, Power Flow – Standby Mode (GRID Input)	31
Figure 3-3, Power Flow – Standby Mode (GEN Input).....	31
Figure 3-4, Automatic 4-Stage Charging Graph.....	33
Figure 3-5, MSH Current Flow – Inverting	34
Figure 3-6, MSH Current Flow – Charging and AC Pass-thru	34
Figure 3-7, MSH Current Flow – Charger Back-off	35
Figure 3-8, MSH Current Flow – Load Support AAC.....	35
Figure 3-9, MSH Current Flow – Load Support VDC	35
Figure 3-10, BTS Temperature to Charge Voltage Change.....	36
Figure 3-11, Power Switch and Status Indicator	38
Figure 4-1, Power Reset	43
Figure A-1, MSH-RE Series Efficiency Chart	45
Figure A-2, MSH4024RE Inverting Temperature Curve	45
Figure A-3, MSH4024RE Charge Current vs Temperature Curve.....	46
Figure B-1, Series Battery Wiring.....	49
Figure B-2, Parallel Battery Wiring	49
Figure B-3, Series-Parallel Battery Wiring	49
Figure B-4, Battery Bank Wiring Examples (24-volt).....	50
Figure C-1, AC Waveforms	51

List of Tables

Table 2-1, Recommended DC Wire/Overcurrent Device for Rated Use	14
Table 2-2, DC Wire Size For Increased Distance	15
Table 2-3, AC Grounding Electrode Conductor Sizing	24
Table 2-4, Equipment Grounding Conductor Sizing	26
Table 3-1, Inverter Battery Turn On/Off Levels.....	37
Table 3-2, Inverter/Charger Default Values	39
Table 3-3, Inverter Compatibility Level	40
Table 3-4, Remote Compatibility Level	40
Table 4-1, Basic Inverter Troubleshooting (Remote not available)	42
Table C-1, Typical Appliance Power Consumption.....	51

1.0 Introduction

Congratulations on your purchase of the MagnaSine Hybrid – Renewable Energy (i.e., MSH-RE) inverter/charger from Magnum Energy. The MSH-RE Series is a “hybrid” pure sine wave inverter designed especially for home backup power and renewable energy applications. Powerful, yet simple to use, this inverter/charger will provide you with years of trouble-free performance you have come to expect from Magnum Energy.

Why is the MSH-RE Series a “Hybrid”? Most inverters only use one source of energy to power the inverter loads—either from the incoming AC power (i.e., utility or AC generator) or from the batteries. The MSH-RE Series combines the energy from both the AC input and the batteries to power the inverter loads. This feature gives this inverter the ability to recharge the battery when there is surplus power or deliver more power to the loads if they require more than the AC input can supply by itself.



Info: This is a sizable manual and much of it is fairly technical. Terms may be used throughout the manual that are unfamiliar to you. Refer to the Inverter/Charger Terminology glossary in Appendix D for clarification.

The MSH-RE Series inverter/charger includes the following:

- a 4000-watt inverter and charger in a small footprint installation
- Pure sine wave output
- Automatic PFC (Power Factor Corrected) multi-stage battery charging
- RS485 standard communication protocol
- Remote and Network ports (easy connection for optional accessories)
- Inverter-mounted ON/OFF switch with LED indicator
- 60-amp AC pass-thru capability
- Field serviceable for qualified personnel—tested repair kits available
- Automatic battery temperature compensation (when using the Battery Temperature Sensor) for optimum charging even during extreme temperature changes
- Overcurrent, over-temperature, and high/low battery voltage protection

The following accessories are also available for use with the MSH-RE Series inverter/charger:

- **ME-AGS-N** (Automatic Generator Start Module – Network version) – automatically starts/stops your generator.
- **ME-ARC50** (Advanced Remote Control) – easy to read LCD display panel that allows advance inverter set up, control, and troubleshooting.
- **ME-BMK** (Battery Monitor Kit - with Shunt) – provides precise DC voltage/current measurements and information on your battery’s State of Charge (SOC) condition.
- **ME-RC50** (Standard Remote Control) – easy to read LCD display panel that allows standard inverter set up, control, and troubleshooting.

Regulatory Compliance

The MSH-RE Series inverter/charger is designated as a Standalone power inverter with an internal battery charger. It can be connected to the utility grid (or to a generator) to allow the inverter batteries to be charged, and to power inverter loads while connected. The MSH-RE series is not a grid-interactive (also known as utility-interactive) inverter and does not have the capability to export (or sell) power back into the utility grid.

The MSH-RE Series is intended to be used for residential or commercial applications. It has been tested and listed to UL 1741, 2nd Edition (Inverters, Converters and Controllers for Use in Independent Power Systems) for use in the US; and is also certified to CSA C22.2 No. 107.1-01 (General Use Power Supplies) for use in Canada. It has been tested and certified to these product safety standards by Intertek Testing Services (known as ETL), which is a Nationally Recognized Testing Laboratory (NRTL). NRTL’s are qualified organizations that meet Occupational Safety and Health Administration (OSHA) regulations to perform independent safety testing and product certification.

Introduction

1.1 How an Inverter/Charger Works

There are two main modes of operation associated with the MSH-RE inverter/charger:

- **Inverter Mode:**

When the inverter is properly connected to batteries and turned on, the direct current (DC) from the batteries is transformed into a pure sine wave alternating current (AC). This AC is similar to the voltage provided by your utility and is used to power any electrical appliances (i.e., AC loads) connected to the inverter's output.

- **Standby Mode:**

When an external source of AC power (i.e., utility power or generator) is connected and qualified on the inverter's AC input, it operates in Standby mode. In Standby mode, an internal AC transfer relay automatically closes to pass the incoming AC power directly to the inverter's output to continue powering the connected electrical appliances. The unit is also monitoring the AC input and "standing-by" to switch to Inverter mode if the unit detects a power failure (or low AC voltage). While in the Standby mode, the unit can operate:

- a) as a battery charger, which converts the incoming AC power into DC power to recharge the batteries; or
- b) in load support, when the incoming AC source is not large enough to power the inverter loads by itself, additional current from the battery is used to ensure the inverter loads continue to be powered.

1.1.1 Inverter Applications for Permanent Installations

An inverter can be used for backup power in a permanent location that normally uses utility power, such as a home or office. When utility power is available, the inverter keeps the batteries charged. When the utility power fails, the inverter comes on automatically to supply AC power to your home or office during the power failure. For a home or business, reliable backup power is needed to prevent lost computer data, or to maintain lights and keep food fresh in the refrigerator/freezer. In some areas, where utility power is not available, this inverter can be used in a standalone renewable power system. The inverter allows AC electrical appliances to be run from the storage battery bank. When the battery bank becomes discharged, either renewable DC sources (solar, wind, or hydro power) can be used to recharge the batteries, or a generator can be connected to the inverter to power the system while the batteries recharge.

1.2 Advantages of using a Pure Sine Wave Inverter

Today's inverters come in three basic output waveforms: square wave, modified sine wave (which is actually a modified square wave), and pure sine wave (see Figure C-1 in Appendix C). Modified sine wave inverters approximate a pure sine wave form and will run most appliances (see also Section C-1 "Appliances and Run Time" in Appendix C) and electronics without any problems. These inverters are less expensive, and therefore, offer a viable alternative to more expensive pure sine inverters.

The output of the MSH-RE Series, which is a pure sine wave inverter, is equal to or in many cases, better than the utility power used in your home. Virtually any electronic device will operate from a pure sine wave inverter. Motors run cooler, microwaves usually cook faster, and clocks keep better time just to name a few examples. Without compromising quality or performance, the MagnaSine-Hybrid provides you with all the advantages of a pure sine wave inverter at a much lower cost than many on the market.

The MSH-RE Series is built on the same platform as our popular ME and RD Series modified sine wave inverters—allowing for an easy upgrade to a pure sine wave inverter from the original ME and RD Series installation. This standard platform also helps reduce cost by using standard parts/accessories across many models. Magnum accessories such as the Advanced Remote Control (ME-ARC), Standard Remote Control (ME-RC), Automatic Generator Start-Networked (ME-AGS-N), and Battery Monitor Kit (ME-BMK) can be used—see Section A-3 "Optional Equipment and Accessories" for more information on these products.

1.3 Features and Benefits

The MSH-RE Series inverter/charger is designed to allow easy access to wiring, circuit breakers, and controls. Its die cast baseplate with one-piece aluminum cover ensures maximum durability with minimum weight, as well as a cooler, more efficient operation.

The front of the MSH-RE inverter is equipped with the following features (refer to Figures 1-1 and 1-2):

- 1 **Power ON/OFF Switch** – a momentary pushbutton switch that alternately turns the inverter on or off.
- 2 **Status LED Indicator** – this green LED illuminates to provide information on inverter or charger operation.
- 3 **Stack/Accessories Connection Port (red label)** – a RJ11 port that accepts optional accessories. *Note: The MSH-RE does not have the ability to be stacked.*
- 4 **Network Connection Port (green label)** – a RJ11 port that accepts optional network capable accessories (i.e., Auto Gen Start or Battery Monitor).
- 5 **Remote Connection Port (blue label)** – a RJ11 port that allows an optional remote control to be connected.
- 6 **Battery Temp Sensor Connection Port (yellow label)** – a RJ11 port that accepts the remote Battery Temperature Sensor (BTS).

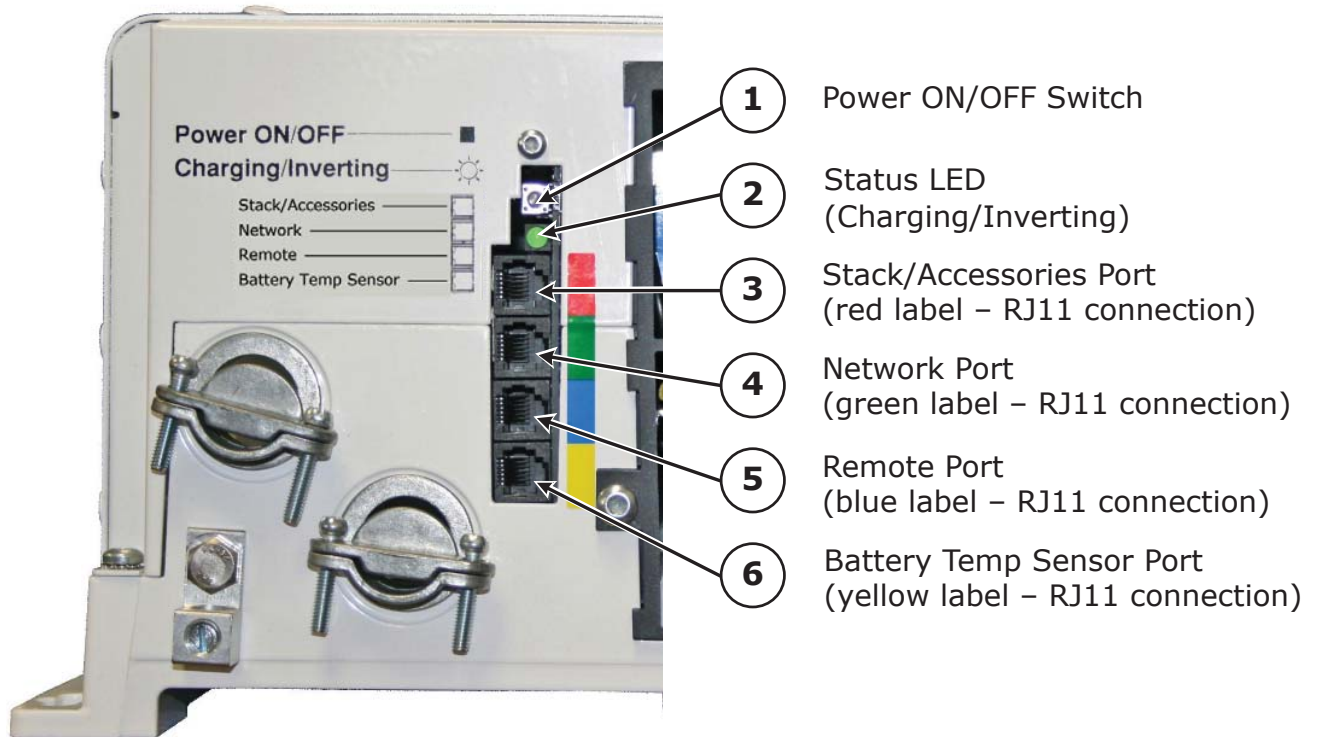

Figure 1-1, Power Switch, Status LED, and Accessory Connection Ports

Introduction

- 7 **DC Equipment Ground Terminal** – this connection is used to tie the exposed chassis of the inverter to the DC grounding system. This terminal accepts CU/AL conductors from #14 to #2 AWG (2.1 to 33.6 mm²).
- 8 **AC Entry/Exit Connections** – two 3/4" knockouts provided with cable-clamp strain reliefs to accommodate and secure the AC input and output field wiring.
- 9 **Intake Air Vents** – ventilation openings to pull in air to help keep the inverter cool for peak performance. The intake air vents are located on the front side and at the front on the right side; see Figure 2-3 for the locations of the air vents.
- 10 **Positive DC Terminal (red)** – provides a 360 degree connection point for the positive (+) cable from the battery bank; consists of a 5/16-18 x 5/8" bolt with a Kep or Flange nut that holds the battery cable to the DC terminal.
- 11 **Negative DC Terminal (black)** – provides a 360 degree connection point for the negative (-) cable from the battery bank; consists of a 5/16-18 x 5/8" bolt with a Kep or Flange nut that holds the battery cable to the DC terminal.
- 12 **Mounting Flange** – used to secure the inverter to a shelf or to a wall.

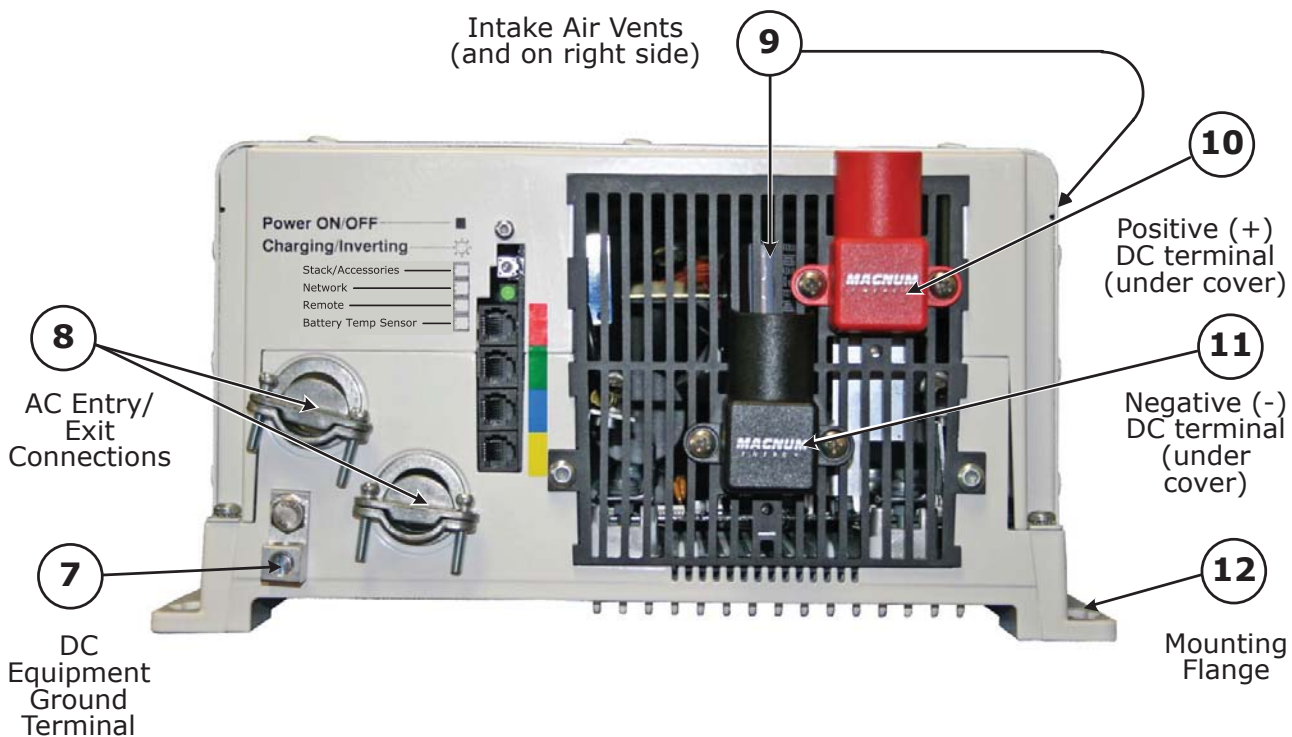

Figure 1-2, Electrical Connection Points

The left side of the MSH-RE Series inverter is equipped with the following features (Figure 1-3):

- 13 **Exhaust Air Vents** – ventilation openings that allow heated air to be removed by the internal cooling fan. The exhaust air vents are located on the back side and at the rear on the right side; see Figure 2-3 for the location of the air vents.
- 14 **Model/Serial Number Label** – includes model/serial number information, date of manufacture, and inverter and charger specifications. See the MSH-RE specifications in Appendix A for more information and a list of available models.
- 15 **AC Access Cover** – provides access to the internal AC wiring terminal block. This terminal block is used to hardwire all inverter AC input and output wiring connections. Remove the two screws to access the AC wiring terminal block.
- 16 **AC Input Circuit Breakers (CB1 & CB2)** – these circuit breakers protect the unit’s internal charger wiring and pass-thru relay while in Standby mode. The circuit breakers pop out when they open—press in to reset. The input circuit breakers are not branch-rated, therefore branch-rated circuit breakers must be installed in the inverter’s input and output wiring.
- 17 **AC Output Circuit Breaker (CB3)** – this 60-amp AC circuit breaker protects the output wiring inside the inverter while load supporting during Standby mode. This output circuit breaker is not branch-rated, therefore any loads connected to the inverter’s output must be protected by an external (HOT 1 and HOT 2) branch-rated circuit breaker. This circuit breaker pops out when it opens—press in to reset.



CAUTION: The inverter’s internal AC transfer relays are rated for 60 amps per input (60 amps for AC HOT 1 and 60 amps for AC HOT 2). The pass-thru current must be no greater than 60 amps or damage to the relays may occur.

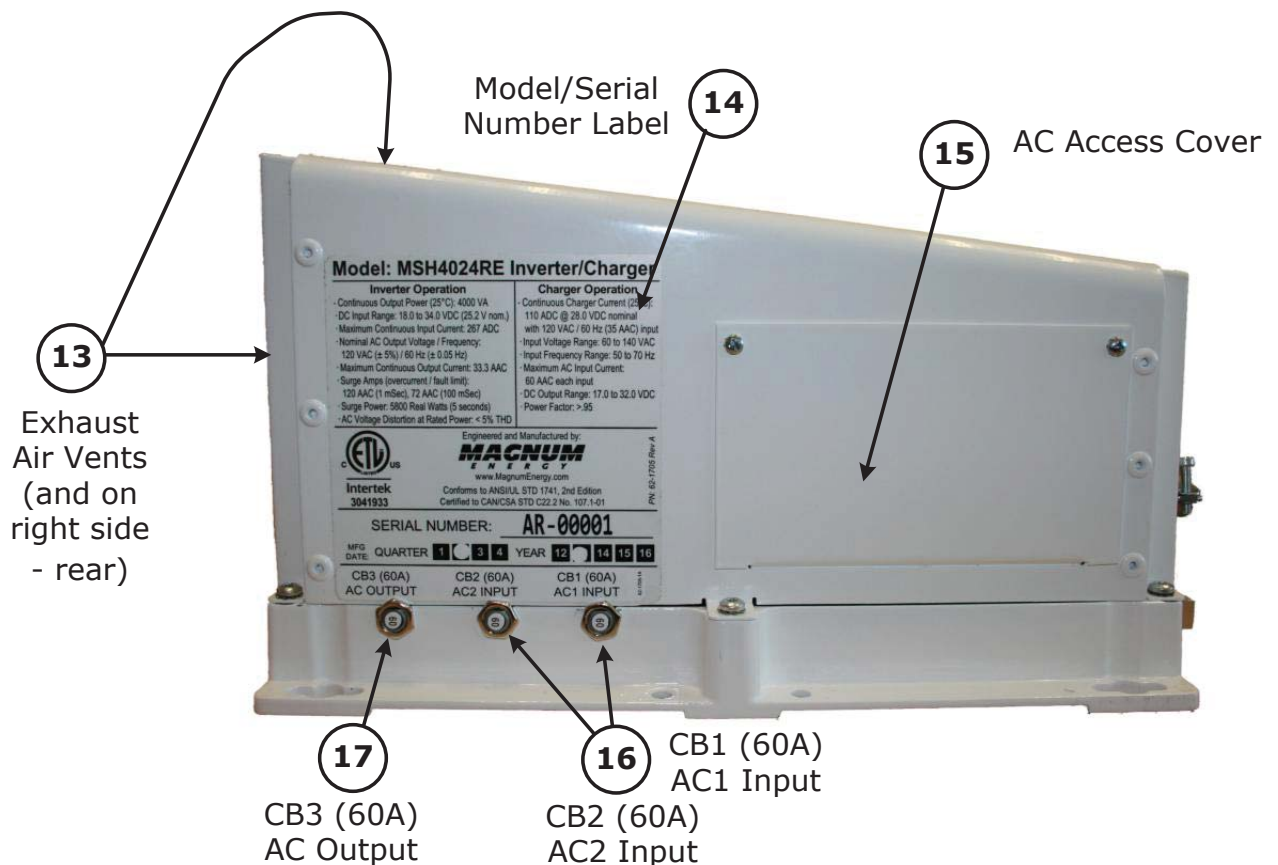

Figure 1-3, Left Side Features

2.0 Installation



WARNING: Installations should be performed by qualified personnel, such as a licensed or certified electrician. It is the installer's responsibility to determine which safety codes apply and to ensure that all applicable installation requirements are followed. Applicable installation codes vary depending on the specific location and application of the installation.



CAUTION: Review the "Important Product Safety Information" on pages ii-v before any installation.



CAUTION: The inverter is heavy. Use proper lifting techniques during installation to prevent personal injury.

The simplified system diagram shown in Figure 2-1 should be reviewed to assist you in planning and designing your installation. This drawing is not intended to override or restrict any national or local electrical codes. This drawing should not be the determining factor as to whether the installation is compliant, that is the responsibility of the electrician and the on-site inspector.

2.1 Pre-Installation

Before proceeding, read the entire Installation section to determine how best to install your MSH-RE inverter/charger. The more thorough you plan in the beginning, the better your inverter needs will be met.

2.1.1 Unpacking and Inspection

Carefully remove the MSH-RE Series inverter/charger from its shipping container and inspect all contents. Verify the following items are included:

- The MSH-RE inverter/charger
- Red and black DC terminal covers with Phillips screws
- AC access cover with two Phillips screws
- Two 5/16" Kep or Flange nuts (installed on the DC terminals)
- Battery Temperature Sensor
- Warning label
- MSH-RE Series Owner's Manual

If items appear to be missing or damaged, contact your authorized Magnum Energy dealer or Magnum Energy. If at all possible, keep your shipping box to help protect your inverter from damage if it ever needs to be returned for service. Save your proof-of-purchase as a record of your ownership; it will also be needed if the unit should require in-warranty service.

Record the unit's model and serial number in the front of this manual in case you need to provide this information in the future. It is much easier to record this information now, instead of trying to gather it after the unit has been installed.

2.1.2 Required Tools and Materials

Hardware/Materials

- Conduit, strain-reliefs and appropriate fittings
- Electrical tape
- 1/4" mounting bolts and lock washers
- Wire ties

Tools

- Miscellaneous screwdrivers
- Drill and drill bits
- Level
- Pliers
- Pencil or marker
- 1/2" wrench
- Wire strippers
- Multimeter

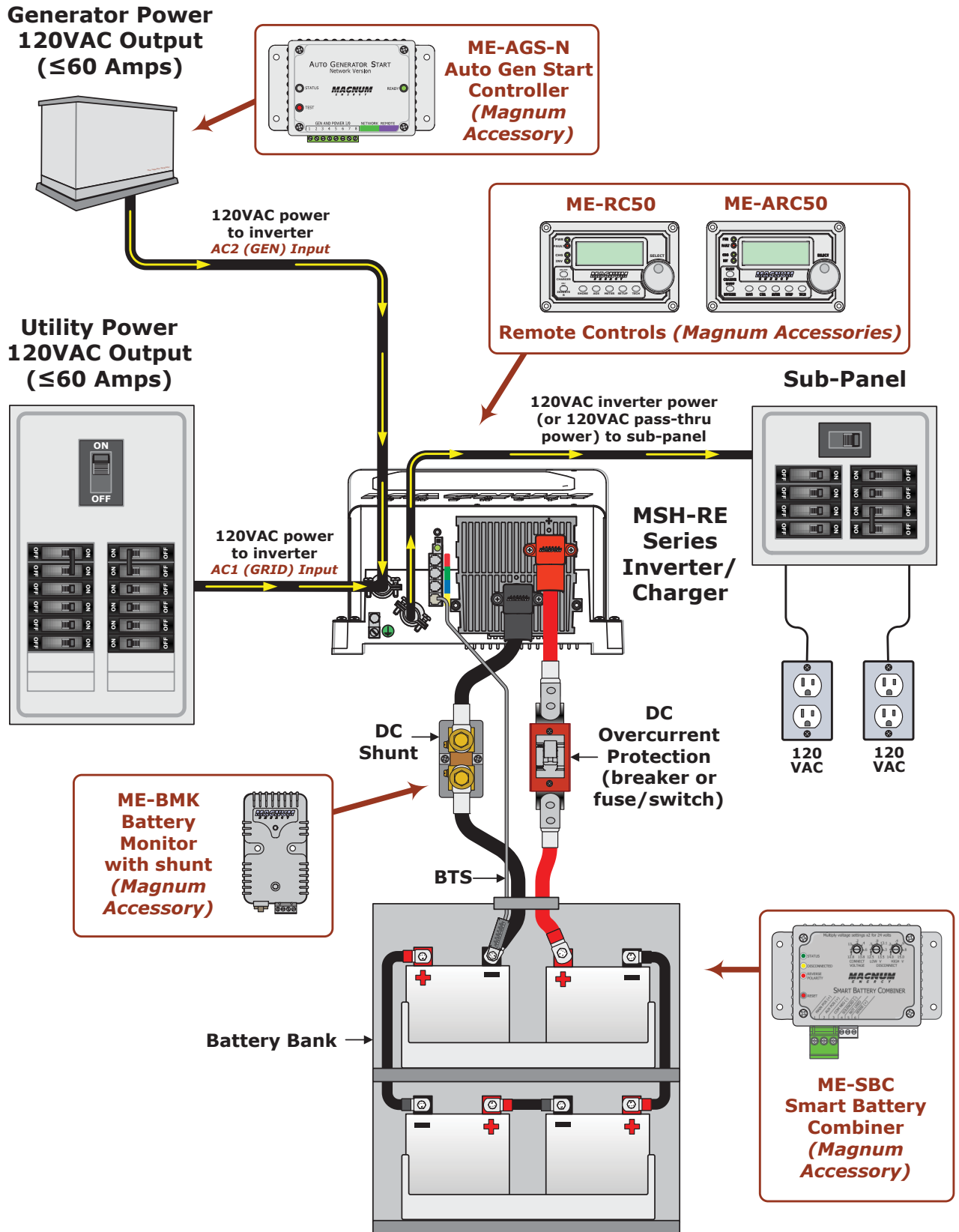

Figure 2-1, Simplified Installation Diagram

Installation

2.1.3 Locating the Inverter

Only install the inverter in a location that meets the following requirements:

Clean and Dry – The inverter should not be installed in an area that allows dust, fumes, insects, or rodents to enter or block the inverter’s ventilation openings. This area also must be free from any risk of condensation, water, or any other liquid that can enter or fall on the inverter. The inverter uses stainless steel fasteners, plated copper busbars, a powder-coated aluminum base and the internal circuit boards are conformal coated—to help fight the harmful effects of corrosive environments. However, the inverter’s life is uncertain if used in these type of environments, and inverter failure due to any of the above conditions is not covered under warranty.



Info: If the inverter is installed in an area where moisture may occur, we recommend putting silicone dielectric grease compound into the electrical ports (Items 3-6 as shown in Figure 1-1). Before installing the cables, or if leaving any ports open, squirt a liberal amount into each port. Silicone dielectric compound makes an effective moisture and corrosive barrier to help protect and prevent corrosion to the RJ11 connections.

Cool – The inverter should be protected from direct sun exposure or equipment that produces extreme heat. The ambient temperature around the inverter must not exceed 77°F (25°C) to meet power specifications.

Ventilation – In order for the inverter to provide full output power and to avoid over-temperature fault conditions, do not cover or block the inverter’s ventilation openings or install this inverter in an area with limited airflow. The inverter uses two fans to provide forced air cooling, these fans pull in air through the intake vents (see Item 9, Figure 1-2) and blow out air through the exhaust vents (see Item 13, Figure 1-3). Allow at the minimum an airspace clearance of 6” (15.2 cm) at the intake and exhaust vents, and 3” (7.6 cm) everywhere else to provide adequate ventilation.

If installed in an enclosure, a fresh air intake opening must be provided directly to the front side (intake vents) of the inverter and an exhaust opening on the back side (exhaust vents) of the inverter. This allows cool air from the outside to flow into the inverter and heated air to exit the inverter and the enclosure. When mounted in an enclosed compartment, airflow must be ≥ 100 cfm in order to maintain no more than a 68°F (20°C) rise in compartment temperature.



CAUTION: Do not mount this inverter in a zero clearance compartment, nor cover or obstruct the ventilation openings—overheating may result.

Safe – Keep any flammable/combustible material (i.e., paper, cloth, plastic, etc.,) that may be ignited by heat, sparks, or flames at a minimum distance of 2 feet (61 cm) away from the inverter.

Close to the battery bank – The inverter should be located as close to the batteries as possible. Long DC wires tend to lose efficiency and reduce the overall performance of an inverter. However, the unit should not be installed in the same compartment as the batteries or mounted where it will be exposed to gases produced by the batteries. These gases are corrosive and will damage the inverter; also, if these gases are not ventilated and allowed to collect, they could ignite and cause an explosion.

Accessible – Do not block access to the inverter’s remote control and accessory ports, as well as the inverter’s controls and status indicator. Allow enough room to access the AC and DC wiring terminals and connections, as they will need to be checked and tightened periodically. See Figure 2-3 for the MSH-RE Series inverter/charger’s dimensions.

Away from sensitive electronic equipment – High powered inverters can generate levels of RFI (Radio Frequency Interference). Locate any electronic equipment susceptible to radio frequency and electromagnetic interference as far away from the inverter as possible.

2.2 Mounting the Inverter

The inverter base can reach a temperature up to 90°C (194°F) and should be mounted on a noncombustible surface*. This surface and the mounting hardware must also be capable of supporting at least twice the weight of the inverter. To meet regulatory requirements, the MSH-RE Series must be mounted in one of the following positions (as shown in Figure 2-2):

- above or under a horizontal surface (shelf or table),
- on a vertical surface (wall) with the DC terminals to the right,
- on a vertical surface (wall) with the DC terminals toward the bottom, the MP-HOOD (inverter hood) installed on the top, and either the ME-CB or MPX-CB (Conduit boxes) or MMP Series (single inverter enclosure) installed on the inverter's bottom.



Info: The ME-CB, MPX-CB, and the MMP Series enclosure prevent material from falling out the bottom in the event of an internal fire, and also allow sufficient ventilation to prevent the inverter from overheating under normal operating conditions. The MP-HOOD inverter hood helps prevent items from falling inside—causing damage to the inverter.



Info: Magnum provides a backplate for mounting the inverter. The backplate (PN: BP-S single plate) also accommodates the mounting of the MMP Series enclosure.

After determining the mounting position, refer to the physical dimensions as shown in Figure 2-3, or use the base of the inverter as a template to mark your mounting screw locations. After marking the mounting screw locations, mount the unit with appropriate mounting hardware.

* *Noncombustible surface – A surface made of material that will not ignite, burn, support combustion, or release flammable vapors when subjected to fire or heat as per the ASTM E136 standard. For the most part, these are materials that are largely comprised of inorganic materials such as stone, steel, iron, brick, tile, concrete, slate, and glass. Avoid common building materials such as gypsum board as well as paint, wall coverings, and any type of wood.*

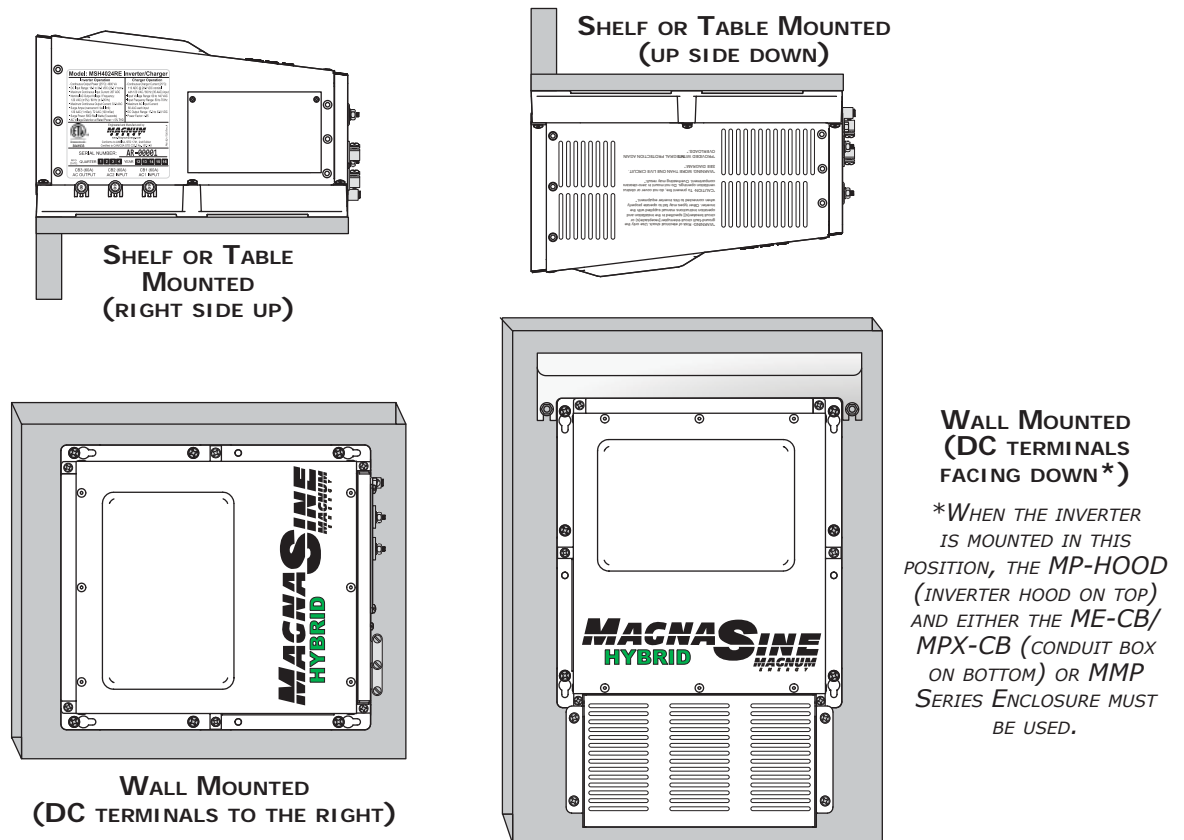

Figure 2-2, Approved Mounting Positions

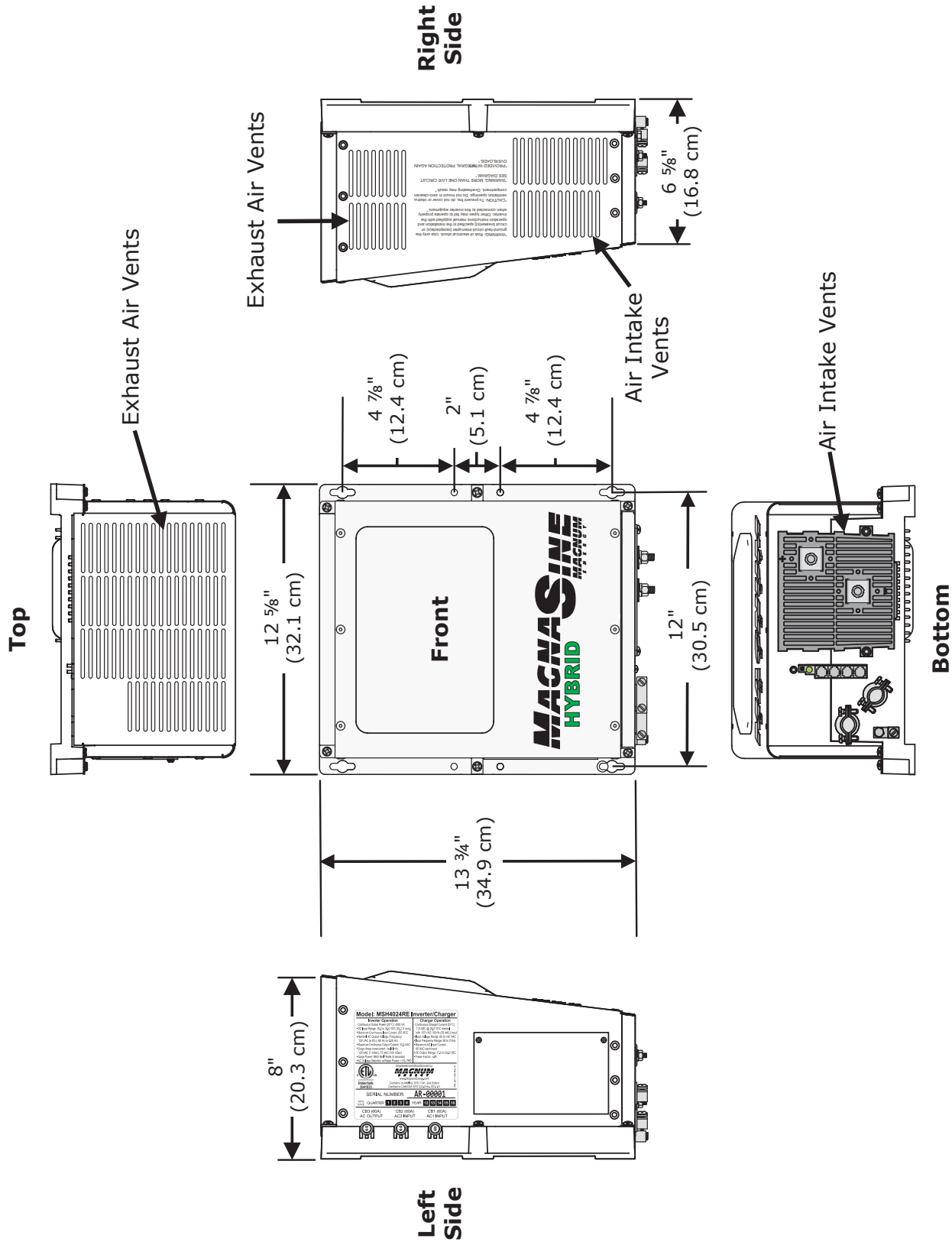

Figure 2-3, MSH4024RE Dimensions and Side Reference

2.3 Wiring the Inverter – General Requirements

This section describes the requirements and recommendations for wiring the MSH-RE Series inverter/charger. Before wiring the MSH-RE Series inverter/charger, carefully read all instructions.

Wiring should meet all local codes and standards and be performed by qualified personnel such as a licensed electrician.

The NEC (National Electric Code, ANSI/NFPA 70) for the United States and the CEC (Canadian Electrical Code) for Canada provide the standards for safely wiring residential and commercial installations. The NEC/CEC lists the requirement for wire sizes, overcurrent protection, and installation methods and requirements.

Inverter/charger systems involve power from multiple sources (inverter, generator, utility, batteries, solar arrays, etc.,) which make the wiring more hazardous and challenging.

The input and output AC and DC circuits are isolated from the inverter chassis. The inverter system grounding is the responsibility of the installer in accordance with the NEC/CEC.



WARNING: Ensure all sources of DC power (i.e., batteries, solar, wind, or hydro) and AC power (utility power or AC generator) are de-energized (i.e., breakers opened, fuses removed) before proceeding—to prevent accidental shock.

2.3.1 Protecting Wire – Conduit Box

The AC and DC wires to and from the inverter must be protected as required by code. This can be done by using jacketed wires or by feeding the wires through conduit. Magnum offers DC conduit boxes (ME-CB or MPX-CB) and a single inverter enclosure (MMP Series) that includes the necessary AC and DC inverter breakers that allow both the AC and DC conduit to be connected to the inverter.



Info: The strain reliefs can be removed and replaced with 3/4" grommets if you are using either a conduit box (ME-CB or MPX-CB) or the MMP enclosure and the AC wires are individual conductors (i.e., not jacketed).

2.3.2 Wiring Requirements

- All conductors that are at risk for physical damage must be protected by conduit, tape, or placed in a raceway.
- Always check for existing electrical, plumbing, or other areas of potential damage prior to making cuts in structural surfaces or walls.
- Do not mix AC and DC wiring in the same conduit or panel unless specifically approved/ designed for both AC and DC wiring. Where DC wiring must cross AC or vice-versa, try to make the wires at the crossing point perpendicular (90 degrees) to one another.
- Both AC and DC overcurrent protection must be provided as part of the installation.
- The inverter requires a reliable negative and ground return path directly to the battery.
- Use only copper wires with a minimum temperature rating of 75°C.

2.3.3 Wire Routing

Before connecting any wires, determine all wire routes to and from the inverter. Typical routing scenarios are:

- AC input wiring from the main AC panel to the inverter.
- AC input wiring from a generator (optional) to the inverter.
- DC input wiring from the batteries to the inverter.
- AC output wiring from the inverter to the AC sub-panel or to dedicated circuits.
- Battery Temperature Sensor cable from the inverter to the batteries.
- Remote control cable (optional) to the inverter.
- Ground wiring to and from the inverter.

2.3.4 Torque Requirements

Torque all AC wiring connections to 32 in lbf (3.6 N-m). Torque DC cable connections from 10 to 12 ft lbf (13.6 to 16.3 N-m).

Installation

2.4 DC Wiring

This section describes the inverter's required DC wire sizes, the recommended disconnect/overcurrent protection, and how to make the DC connections to the inverter and the battery bank. Refer to Figure 2-4 when connecting the DC wires.



WARNING: Even though DC voltage is “low voltage”, significant hazards may be present, particularly from short circuits of the battery system.



CAUTION: The inverter is NOT reverse polarity protected—which means that if the negative and positive battery voltage is connected backwards to the inverter, the inverter will likely be damaged. You should verify the correct voltage polarity using a voltmeter BEFORE connecting the DC wires.



CAUTION: Before wiring the DC cables, review the safety information at the beginning of this manual and the information below to ensure a safe and long-lived system.



Info: DO NOT connect the battery cables to the inverter until all wiring is complete and the correct DC voltage and polarity have been verified.

- When the inverter is installed in a photovoltaic system, the NEC requires that the DC circuit conductors and overcurrent devices to the inverter be sized to carry not less than 125% of the inverter's maximum current rating.
- The DC positive and negative cables connected to the inverter from the battery bank should be tied together with wire ties or electrical tape approximately every 6 inches (15.2 cm). This helps improve the surge capability and reduces the effects of inductance, which improves the inverter waveform and reduces the wear of the inverter's filter capacitors.
- Crimped and sealed copper ring terminal lugs with a 5/16" hole should be used to connect the DC wires to the inverter's DC terminals.
- The battery bank voltage MUST match the DC voltage required by the inverter (i.e., 24-volt battery bank for a 24-volt inverter) or the inverter may be damaged.
- To ensure the maximum performance from the inverter, all connections from the battery bank to the inverter should be minimized. The exception is the DC overcurrent disconnect in the positive line and a shunt in the negative line. Any other additional connection will contribute to additional voltage drops, and these extra connection points may loosen during use.
- All wiring to the battery terminals should be checked periodically (once a month) for proper tightness. The torque requirement for the DC terminals is between 10 to 12 ft lbf (13.6 to 16.3 N-m). If you don't have a torque wrench, ensure all DC terminals are tight and cannot move.
- Be aware that overtightening or misthreading the nuts on the DC terminals can cause the bolts to strip and snap/break off.
- Make sure cables have a smooth bend radius and do not become kinked. Place long cable runs in conduit and follow existing wire runs where possible.
- A brief spark or arc may occur when connecting the battery cables to the inverter DC terminals; this is normal and due to the inverter's internal capacitors being charged.
- Color code the DC cables/wires with colored tape or heat shrink tubing: RED for positive (+); WHITE for negative (-); and GREEN (or bare copper) for DC ground, to avoid polarity problems.

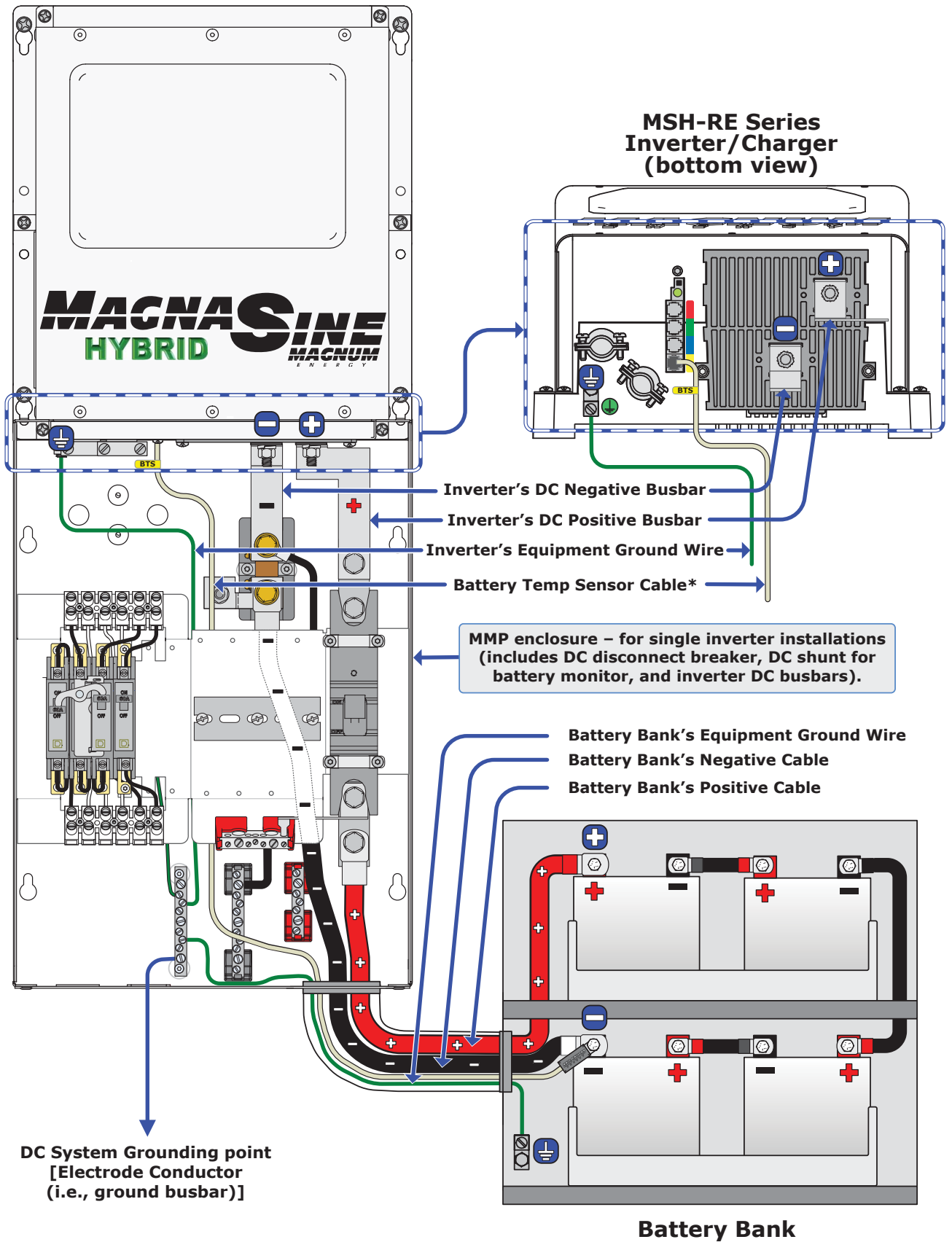

Figure 2-4, DC and Battery Temperature Sensor Wiring

Installation

2.4.1 DC Wire Sizing

It is important to use the correct sized DC wire to achieve maximum efficiency from the system and to reduce fire hazards associated with overheating. Always keep your wire runs as short as practical to prevent low voltage shutdowns and to keep the DC breaker from nuisance tripping (or open fuses) because of increased current draw. See Table 2-1 to select the minimum DC wire size (and corresponding overcurrent device) required based on your inverter model. The cable sizes listed in Table 2-1 are required in order to reduce stress on the inverter, minimize voltage drops, increase system efficiency, and ensure the inverter's ability to surge heavy loads.

If the distance from the inverter to the battery bank is >5 feet, the DC wire will need to be increased. Longer distances cause an increase in resistance, which affects the performance of the inverter. Use the overcurrent device previously determined from Table 2-1 and then refer to Table 2-2 to determine the minimum DC wire size needed for various distances, based on your inverter model.

2.4.2 DC Overcurrent Protection

DC overcurrent protection is not included in the inverter—for safety reasons and to comply with electrical code regulations—it must be provided as part of the installation. The DC overcurrent protection device must be installed in the positive DC cable line, it can be a fuse or a circuit breaker and must be DC rated. It must be correctly sized according to the size of DC cables being used, which means it is required to open before the cable reaches its maximum current carrying capability, thereby preventing a fire. In a residential or commercial electrical installation, the NEC requires both overcurrent protection and a disconnect switch. If a circuit breaker is used as the overcurrent protection device, it can also be used as the required DC disconnect.

If a fuse is used as an overcurrent device, a Class-T type or equivalent is recommended. This fuse type is rated for DC operation, can handle high short-circuit currents, and has a time delay that allows for momentary current surges from the inverter without opening the fuse. However, because the fuse can be energized from both directions, the NEC requires that it be installed in a manner that the power must be disconnected on both ends of the fuse before servicing.

Use Table 2-1 to select the DC overcurrent device needed based on the recommended minimum wire size for your particular inverter model (may not meet all local code or NEC requirements).

Table 2-1, Recommended DC Wire/Overcurrent Device for Rated Use

Inverter Model	Maximum Continuous Current ¹	Using Conduit		In Free Air		DC Grounding Electrode Wire Size ⁴
		Minimum DC Wire Size (rating) ²	Recommended DC Breaker Size	Minimum DC Wire Size (rating) ²	Maximum DC Fuse Size ³	
MSH4024RE	222 amps	#4/0 AWG (107.2mm ²) 260 amps	250 amps ⁵	#2/0 AWG (67.4mm ²) 300 amps	300 amps with time delay	#6 AWG (13.3mm ²)

Note¹ – Maximum continuous current is based on the inverter's continuous power rating at the lowest input voltage with an inverter inefficiency factored in.

Note² – Copper wire rated with 90°C (194°F) insulation at an ambient temperature of 30°C (86°F), with a multiple cable fill factor (0.8) de-rating (if needed).

Note³ – The next larger standard size overcurrent device may be used if the derated cable ampacity falls between the standard overcurrent devices found in the NEC.

Note⁴ – Per the NEC, the DC grounding electrode conductor can be a #6 AWG conductor if that is the only connection to the grounding electrode and that grounding electrode is a rod, pipe, or plate electrode.

Note⁵ – May not allow continuous operation at full rated power as defined by the NEC.

Table 2-2, DC Wire Size For Increased Distance

Inverter Model	Minimum Recommended DC Wire Size (one way)*					
	5 feet or less		5 to 10 feet		10 to 15 feet	
	In Conduit	In Free Air	In Conduit	In Free Air	In Conduit	In Free Air
MSH4024RE	#4/0 AWG (107.2mm ²)	#2/0 AWG (67.4mm ²)	#4/0 AWG (107.2mm ²) x2	#4/0 AWG (107.2mm ²)	not recommended	#4/0 AWG (107.2mm ²) x2

* Copper wire rated with 90°C (194°F) insulation at an ambient temperature of 30°C (86°F)

2.4.3 DC Cable Connections

Do not put anything between the battery cable ring lug and the battery post or the flat metal part of the inverter’s DC terminal. When connecting the battery cable to the battery post or inverter DC terminal, the cable should be placed directly against the inverter terminal or battery post. Incorrectly installed hardware causes a high resistance connection which could lead to poor inverter/charger performance, and may melt the cable and terminal connections.

Refer to Figures 2-5 and 2-6 to connect the DC cables and to stack the hardware correctly. Tighten the terminal connections from 10 to 12 ft lbf (13.6 to 16.3 N-m).



CAUTION: The DC terminal and Flange/Keyp nuts are made of stainless steel which have a high likelihood of seizure. To help prevent the bolt and nut from seizing—causing the bolts to strip or snap/break-off—the use of anti-seize lubricant is highly recommended.



Info: If antioxidant grease or spray is used, apply it after all the connections have been made and are properly tightened.



Info: A 1/2-inch wrench or socket is used to tighten the 5/16 SAE Flange/Keyp nuts.

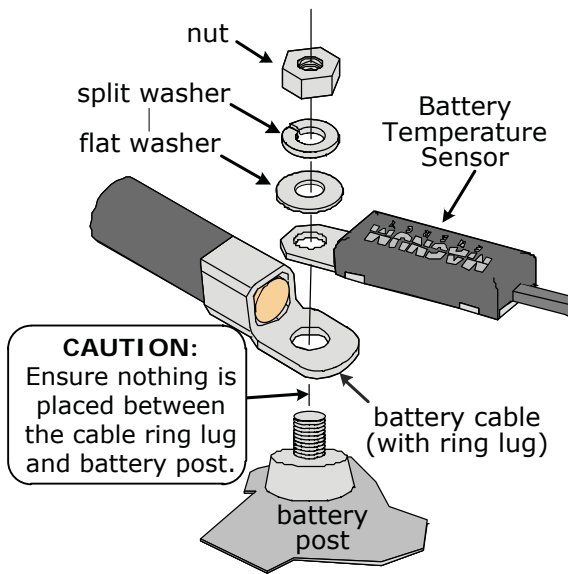

Figure 2-5, Battery Hardware Installation

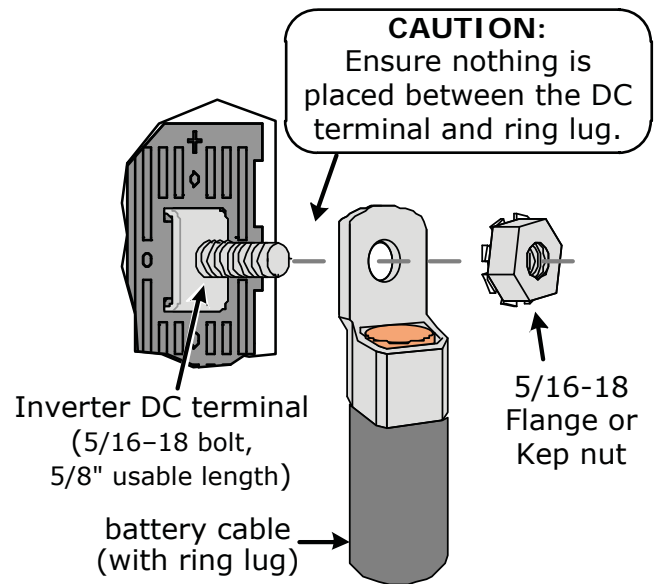

Figure 2-6, Inverter DC Hardware Installation

Installation

2.4.4 Wiring the DC Overcurrent Protection Device

A fuse/disconnect or circuit breaker must be provided in the DC positive line between the battery and the inverter to protect the DC wiring system. Mount the fuse block (or circuit breaker assembly) as near as practical to the batteries. For maximum protection, install it within 18 inches (45 cm) of the battery.

1. Open the fuse disconnect (or open the circuit breaker) and connect a short cable (same rating as the battery cables) to one end of the fuse block.
2. Connect the short cable to the positive battery terminal.
3. Connect the positive cable (RED) from the inverter to the fuse/disconnect (or circuit breaker) assembly. DO NOT connect the positive cable to the inverter at this time.
4. Securely tighten the fuse/disconnect (or circuit breaker) connection lugs. Once the entire installation is complete and all connections are verified, close the fuse disconnect (or circuit breaker) to provide power to the inverter.

2.4.5 Wiring the Battery Bank



WARNING: Lethal currents will be present if the positive and negative cables attached to the battery bank touch each other. During the installation and wiring process, ensure the cable ends are insulated or covered to prevent touching/shorting the cables.



Info: DO NOT connect the DC wires from the battery bank to the inverter until 1) all DC and AC wiring is complete, 2) the correct DC and AC overcurrent protection has been installed, and 3) the correct DC voltage and polarity have been verified.



Info: For the MSH-RE Series inverter/charger to perform optimally, a minimum battery bank of 200 AH is recommended for moderate loads (<1000W) and greater than 400 AH for heavy loads (≥1000W).

Depending upon the voltage of the batteries you use in the installation (6 or 12 VDC), the batteries must be wired in series, parallel, or series-parallel to provide the correct voltage (see Appendix B - Battery Information for guidance on wiring batteries together). The interconnecting DC wires must be sized and rated exactly the same as those used between the battery bank and the inverter. Place the batteries as close as practical to the inverter, preferably in an insulated and ventilated enclosure. Allow adequate space above the batteries to access the terminals and vent caps (as applicable). Also, allow at least 1" of space between the batteries to provide good air flow. DO NOT mount the batteries directly under the inverter.



CAUTION: Install batteries in a well ventilated area. Batteries can produce explosive gasses. For compartment or enclosure installations, always vent batteries to the outside.



Info: To ensure the best performance from your inverter system, batteries should be of the same size, type, rating, and age. Do not use old or untested batteries.

2.4.6 Battery Temperature Sensor Installation and Wiring

The Battery Temperature Sensor (shown in Figure 2-7) provides the inverter with precise battery temperature information to automatically adjust the ABSORB and FLOAT charge voltage set-points. This allows the batteries to be correctly charged under extreme temperature changes.

If the temperature sensor is NOT installed and the batteries are subjected to large temperature changes, the battery life may be shortened.

The BTS cable may be extended—using a RJ11 connector (female to female) and a standard phone cable with RJ11 connectors—to a maximum length of 40 feet (12 m). However, your inverter to battery cable length should not exceed the recommended distance provided in Table 2-2.

To install the BTS:

1. Attach the ring terminal end of the Battery Temperature Sensor to the negative battery terminal; see Figure 2-5 for proper connection to the battery terminal.
2. Route the sensor's cable to the inverter following existing wire runs.
3. Connect the RJ11 connector end of the BTS cable to the yellow-labeled BTS port on the inverter (Item 6, Figure 1-1).

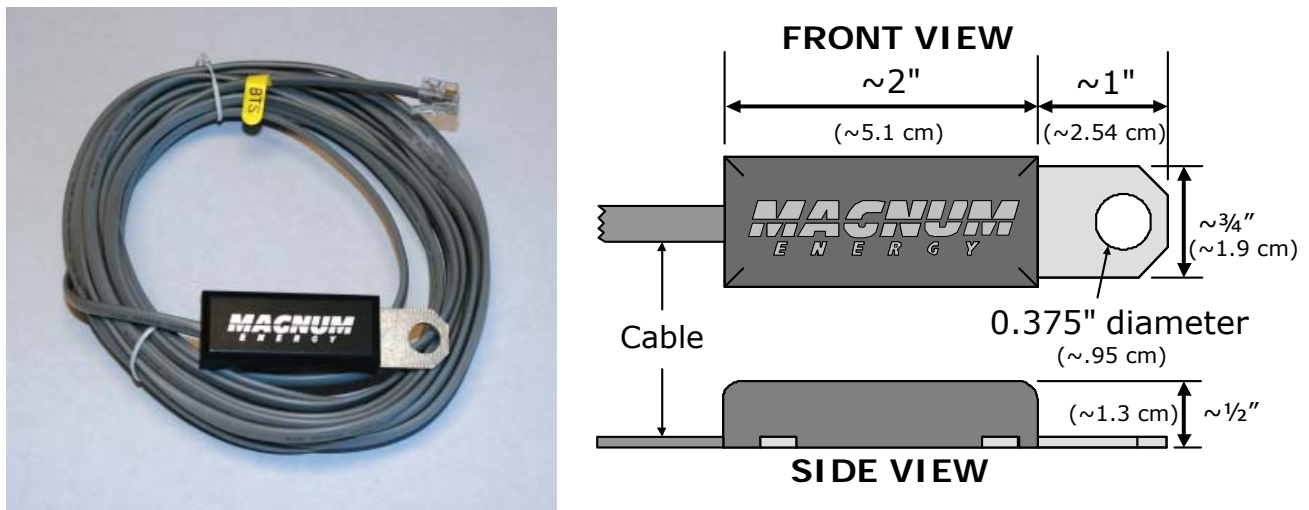

Figure 2-7, Battery Temperature Sensor

Installation

2.4.7 Wiring the Inverter to the Battery Bank



CAUTION: The inverter is NOT reverse polarity protected—if this happens the inverter will be damaged and will not be covered under warranty. Before connecting the DC wires from the batteries to the inverter, verify the correct battery voltage and polarity using a voltmeter. If the positive terminal of the battery is connected to the negative terminal of the inverter and vice versa, severe damage will result. If necessary, color code the cables (with colored tape): red for positive (+), and white for negative (-) to avoid polarity confusion.



Info: The DC overcurrent device (i.e., circuit breaker or fuse) must be placed in the positive (red) DC cable line between the inverter's positive DC terminal and the battery's positive terminal (red)—as close to the battery as possible.

DC Ground Wire

Route an appropriately sized DC grounding wire (green or bare wire) from the inverter's DC equipment ground terminal (Item 7, Figure 1-2) to a dedicated system ground. Recommended tightening torque is 45 in lbf (5.1 N-m). Refer to Section 2.6 for grounding information and sizing the DC ground wires.

DC Negative Wire

Route an appropriately sized DC negative wire (marked white) from the negative terminal of the battery bank to the inverter's negative terminal (Item 11, Figure 1-2).



Info: If installing a battery monitor such as Magnum's ME-BMK, install a DC shunt in-line with the negative battery cable.

DC Positive Wire

Mount the circuit breaker or fuse assembly as near as practical to the batteries and leave open (i.e., no power to inverter).



WARNING: DO NOT close the DC circuit breaker or connect the fuse to connect battery power to the inverter at this time. This will occur in the **Functional Test** after the installation is complete.



CAUTION: If connecting live battery cables to the inverter DC terminals, a brief spark or arc may occur; this is normal and due to the inverter's internal capacitors being charged.

Route and connect an appropriately sized DC positive wire (red) from the inverter's positive DC terminal (Item 10, Figure 1-2) to one end of circuit breaker (or DC fuse block).

Connect a short wire (same rating as the DC wires) to the other side of the DC circuit breaker (or one end of the fuse/disconnect assembly) and the other end of the short wire to the positive terminal of the battery bank (see Figure 2-1 for reference). This is essential to ensure even charging and discharging across the entire battery bank.

Ensure the DC wire connections (on the batteries, inverter, and DC circuit breaker/fuse lugs) are flush on the surface of the DC terminals, and the hardware (lock washer and nut) used to hold these connections are stacked correctly (see Figures 2-5 and 2-6). Verify all DC connections are torqued from 10 to 12 ft lbf (13.6 to 16.3 N-m).

Once the DC connections are completely wired and tested, coat the terminals with an approved anti-oxidizing spray.

Attach the red and black terminal covers over the inverter's DC connectors and secure them in place with the supplied screws.

If the batteries are in an enclosure, perform a final check of the connections to the battery terminals, then close and secure the battery enclosure.

2.5 AC Wiring

This section provides information on how to make the AC connections to the inverter using the correct AC wire size and corresponding overcurrent protection.

2.5.1 Pre-AC Wiring Requirements



CAUTION: Before installing any AC wiring, review the safety information at the beginning of this manual and the following to ensure a safe and long-lived system:

- Always use properly rated circuit breakers. If using an electrical sub-panel, circuit breakers can be moved from the main electrical panel to the sub-panel only if the breakers are also listed to be installed in the sub-panel.
- AC wiring must be no less than #6 AWG (13.3 mm²) gauge copper wire and be approved for the application (i.e., residential wiring).
- DO NOT connect the inverter's output to an external AC power source unless used in an AC Couple application*. Otherwise, severe damage to the inverter may occur and this damage is easily detected and not covered under warranty.

* This inverter has the ability to be used in an AC Couple application. In an AC Couple application, the Magnum inverter's output is connected to the output of a grid-tie inverter to provide the AC reference for the grid-tie inverter. This causes the grid-tie inverter's output to be synchronized to the Magnum inverter's output so that the two AC outputs can be connected together without any damage occurring to the Magnum inverter.

- The wire sizes recommended in this manual are based on the ampacities given in Table 310.16 (in conduit) or Table 310.17 (in free air) of the NEC, ANSI/NFPA 70, for 75°C (167°F) copper wire based on an ambient temperature of 30°C (86°F).



WARNING: To reduce the risk of fire, do not connect this inverter to an AC load center (circuit breaker panel) having multi-wire branch circuits connected.

2.5.2 AC Wire Size and Overcurrent Protection

The AC input and output wiring must be sized per the local electrical safety code requirements to ensure the wire's ability to safely handle the inverter's maximum load current. The AC wiring must be protected from short circuits and overloads by an overcurrent protection device and have a means to disconnect the AC circuits. AC overcurrent protection is not included in the inverter and must be provided as part of the inverter installation. The AC overcurrent protection device must be a circuit breaker or a fuse/disconnect and be properly sized and branch circuit rated for the wire it is protecting and the appliances being powered.



Info: When wiring the AC input and output circuits, we highly recommend a full system Inverter Bypass Switch. This simple item provides a convenient way to isolate the inverter for battery maintenance, and it could save you hours of downtime—if you ever need to service your inverter—by enabling you to continue to power your AC loads without any re-wiring. Because we think it is an essential part of an inverter system, every Magnum panel (MMP Series) is equipped with an Inverter Bypass Switch.

When the inverter is in Standby mode, the full AC continuous pass-thru capacity of the MSH-RE Series inverter/charger is 60 amps (GRID IN/AC1 and GEN IN/AC2). If you are using other circuit breakers/wire sizes, refer to the appropriate electrical codes for sizing requirements.



CAUTION: The inverter's internal AC transfer relay contacts are rated for 60 amps, the pass-thru current for relay contact must be no greater than 60 amps or damage to this relay may occur.

Installation

2.5.3 Recommended GFCI (Ground Fault Circuit Interruption) Outlets

In compliance with UL standards, Magnum Energy has tested the following GFCIs and find that they function properly when connected to the inverter's AC output:

- Shock Sentry™ #XGF15V-SP
- Leviton Smart Lock #8899-A
- Hubbel #GF520EMBKA

2.5.4 AC Terminal Block Connections

The inverter has a six-pole AC terminal block and two AC ground terminals to connect the inverter's AC input and output wiring. The MSH-RE Series provides a terminal block (see Figure 2-8) that allows the AC input and output wiring to be permanently wired. This terminal block allows either a service/distribution panel (main panel) or a generator to be wired to the inverter's input, and then to a dedicated panel (sub-panel) between the inverter's output wiring and the AC loads. To access and view the AC terminal block and ground terminal, remove the two Phillips screws holding the AC wiring access cover plate (see Item 15, Figure 1-3).

Each connection on the AC terminal block is rated for 105°C and can accept one #18 to #2 AWG (0.82 to 33.6 mm²) CU stranded wire; or two #14 to #8 AWG (2.1 to 8.7 mm²) CU stranded wires. Each connection uses a 1/4-28 screw and the maximum tightening torque is 32 in lbf (3.6 Nm).



Info: The inverter's NEUTRAL IN and NEUTRAL OUT terminals are electrically connected to each other and either connection can be for the input or output neutrals.

The AC ground terminals can accept one #14 to #6 AWG (2.1 to 13 mm²) CU stranded wire each. They use a slotted head screw and have a recommended maximum tightening torque of 45 in lbf (5.1 N-m).

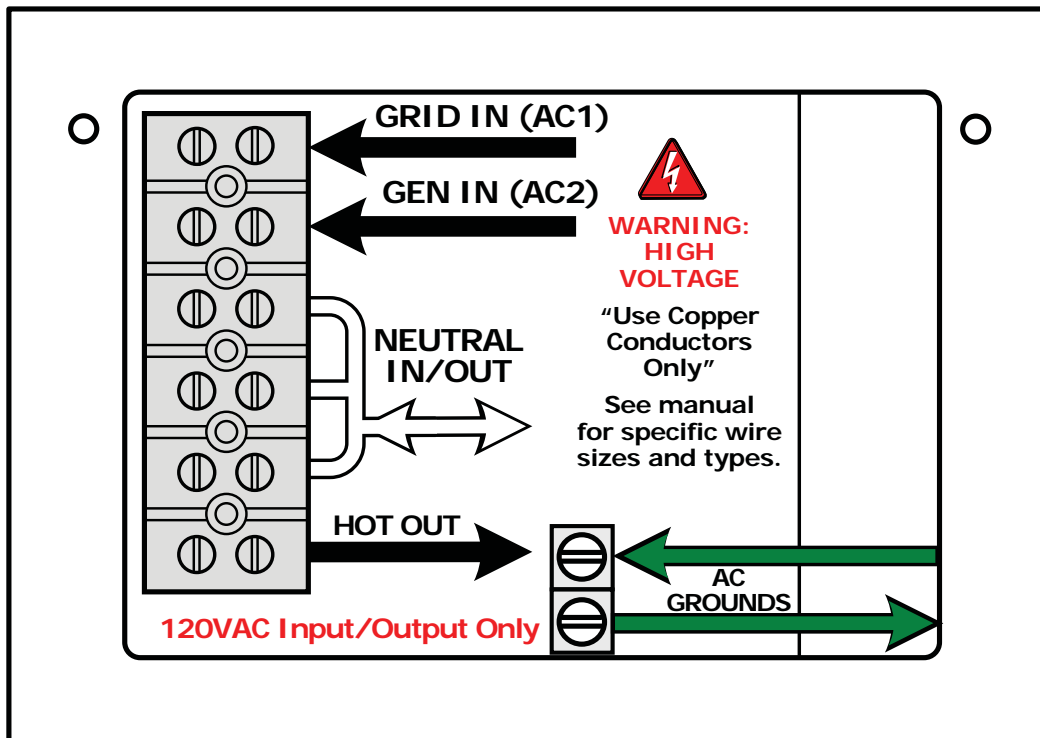

Figure 2-8, AC Terminal Block

2.5.5 AC Conductor Wiring

The following steps are basic guidelines for installing and connecting AC wiring to and from an MSH-RE Series inverter. The first section covers the AC wiring needed to connect the inverter to utility power, and the second section covers the AC wiring needed to connect the inverter to a generator.



WARNING: Before making any AC connections, make sure the inverter is disconnected from the battery and no AC power is connected to the inverter.



Info: Connecting to either AC1 or AC2 input allows battery charging.

Remove the two Phillips screws on the AC wiring access cover (Item 15, Figure 1-3) to access the internal AC terminal block (see Figure 2-8).

Wiring the Inverter AC1 Input (Grid/Utility)

1. Route the wires (HOT1, NEUTRAL1, and GROUND1) from the AC electrical main panel through one of the strain relief clamps on the inverter (Item 8, Figure 1-2). Tighten the strain relief clamp securely on the wires. Always leave a little extra slack in the wiring. Refer to Figure 2-9.
2. Connect the HOT1 wire (black) from the main panel's dedicated breaker to the inverter's AC1 (GRID IN) terminal.
3. Connect the NEUTRAL1 (white) from the main panel's neutral busbar to the inverter's NEUTRAL IN terminal.
4. Connect the GROUND1 (green or bare copper) wire from the inverter's AC GROUNDS terminal to the main panel's ground busbar.

Wiring the Inverter AC2 Input (Generator)

1. Route the wires (HOT2, NEUTRAL2, and GROUND2) from the generator through one of the strain relief clamps on the inverter (Item 8, Figure 1-2). Tighten the strain relief clamp securely on the wires. Always leave a little extra slack in the wiring. Refer to Figure 2-9.
2. Connect the HOT2 wire (black) from the generator's dedicated breaker to the inverter's AC2 (GEN IN) terminal.
3. Connect the NEUTRAL2 (white) from the generator's neutral busbar to the inverter's NEUTRAL IN terminal.
4. Connect the GROUND2 (green or bare copper) wire from the inverter's AC GROUNDS terminal to the generator's ground busbar.

Wiring the Inverter AC Output

1. Route the wires (HOT, NEUTRAL, GROUND) through the unused strain relief clamp on the inverter (Item 8, Figure 1-2) to the AC electrical sub-panel (or outlets, if using the output breaker versions). Tighten the strain relief clamp securely on the wires.
2. Connect the HOT (black) wire from the inverter's HOT OUT terminal to the sub-panel's main breaker.
3. Connect the NEUTRAL (white) from the inverter's NEUTRAL OUT terminal to the sub-panel's neutral busbar (or to the neutral connection on the outlets if using the output breaker versions).
4. Connect the GROUND (green or bare copper) wire from the inverter's AC GROUNDS terminal to the sub-panel's ground busbar.

AC Wiring Inspection

1. Verify all wire runs are secured. If installed in a mobile installation, use wire ties or other non-conductive fasteners to prevent chafing or damage from movement and vibration.
2. Verify strain reliefs or grommets are in place to prevent damage to the wiring or conduit where it passes through walls or other openings.
3. Verify that all AC connections are correct, all the inverter AC terminal screws are torqued to a maximum tightening torque of 32 in lbf (3.6 N-m), and the AC ground terminal is torqued to a maximum tightening torque of 45 in lbf (5.1 N-m).
4. Replace the AC wiring access cover and the covers on the main electrical/distribution panel.

Installation

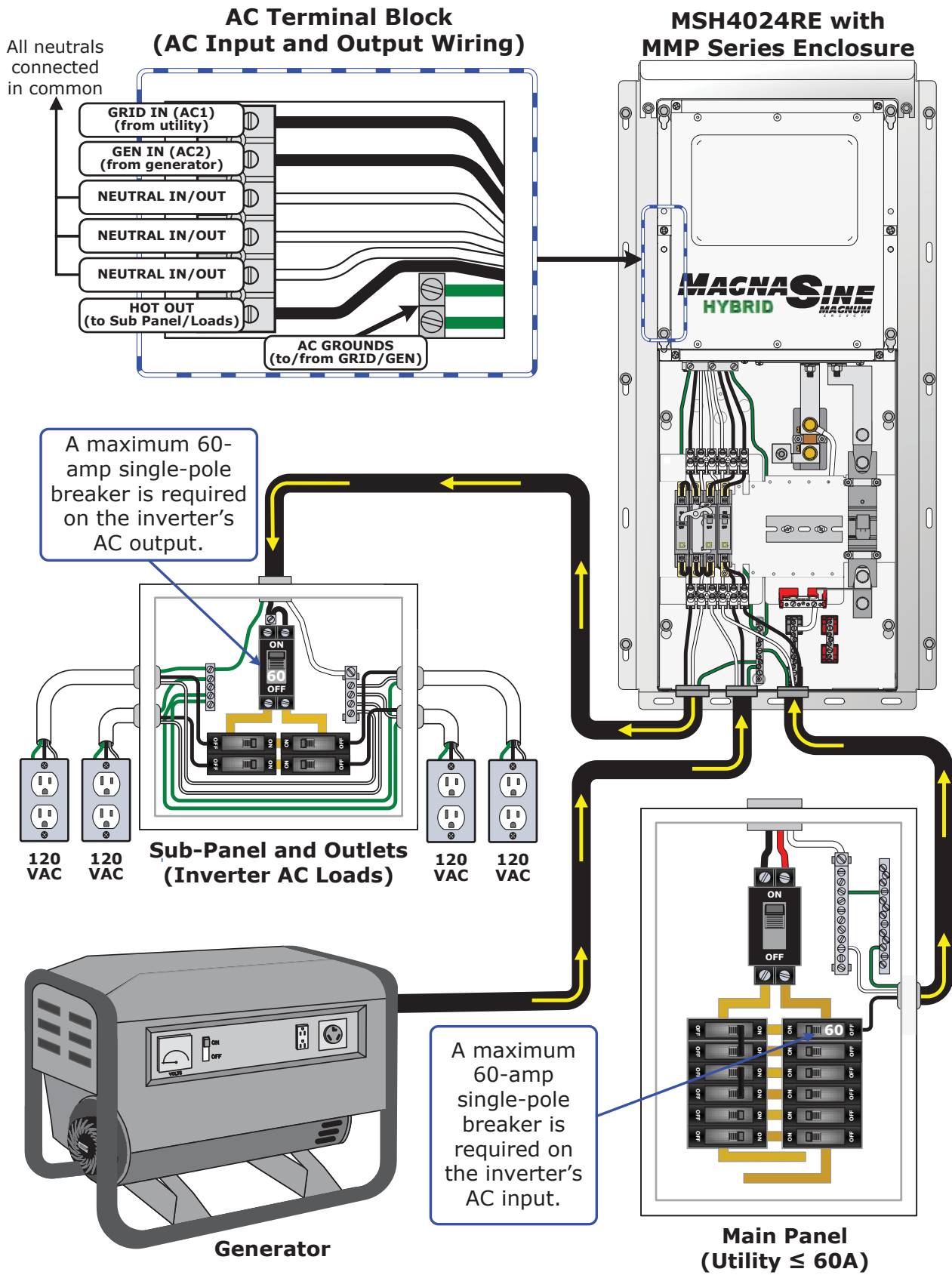

Figure 2-9, AC Wiring

2.6 Grounding Inverters

The inverter/charger should always be connected to a permanent, grounded wiring system. A properly grounded system limits the risk of electrical shock, reduces radio frequency noise from the inverter, and minimizes excessive surge voltages induced by lightning. Ensure there is a well-defined, low-resistance path from the electrical system to the grounding system. The low-resistance path helps stabilize the electrical system voltage with respect to ground and carries fault currents directly to ground if the electrical system malfunctions. Review the following terms to understand how the conductors in the electrical circuit will be connected to the system ground:

- **Grounded Conductor (GC):** The wire/cable in the electrical system that normally carries current (usually AC neutral and/or DC negative), and is intentionally connected or “bonded” to the ground system. This wire, or the ends of this wire, should be colored white or gray.
- **Equipment Grounding Conductor (EGC):** A wire/cable that does not normally carry current and is used to connect the exposed metal parts of equipment—that might be accidentally energized—to the grounding electrode system or to the grounded conductor. This wire, or the ends of this wire, should be green or green with a yellow stripe; this wire can be bare copper.
- **Grounding Electrode Conductor (GEC):** The wire/cable that does not normally carry current and connects the grounded conductor and/or the equipment grounding conductor to the grounding electrode at the service equipment.
- **Grounding Electrode (GE):** A ground rod or conducting element that establishes an electrical connection to the earth.
- **System bonding jumper (SBJ):** The connection between the grounded circuit conductor in the electrical system and the equipment grounding conductor at a separately derived system.

The MSH-RE Series inverter/charger uses both AC and DC power; however, the AC electrical system is isolated from the DC electrical system by an internal transformer. Although this inverter/charger has two electrical systems, each electrical system must be properly grounded and connected to a common “earth” reference. Refer to Figure 2-10.

For proper grounding, each electrical system must connect all exposed metal parts of equipment (via EGC) and one of the current-carrying conductors (GC) together at a common point (ground busbar—GBB), usually by a system bonding jumper (SBJ) in an electrical service disconnect panel. The common point of each electrical system is then connected (via GEC) to the common ground reference, such as a ground rod (GE). This connection to earth should only be made at one point in each electrical system; otherwise, parallel paths will exist for the currents to flow. These parallel current paths would represent a safety hazard and are not allowed in installations wired per the NEC/CEC.

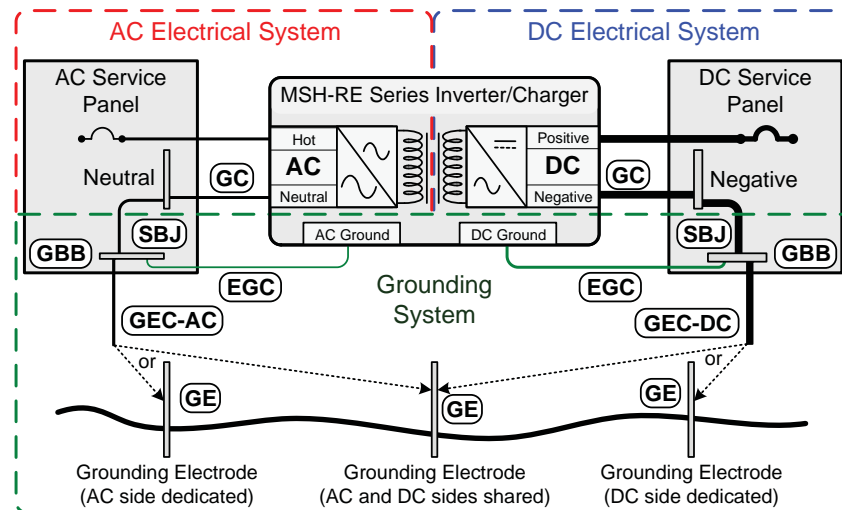

Figure 2-10, Grounding System for MSH-RE

Installation

2.6.1 Sizing the Grounding Electrode Conductors

AC Side – The size of the AC grounding electrode conductor (GEC-AC) depends on the size of the largest ungrounded conductor feeding the AC load center. One #8 AWG (8.4 mm²) copper conductor will serve as an AC grounding electrode conductor (GEC-AC) for AC power conductors smaller than and including #2 AWG (33.6 mm²) copper. See Table 2-3 for additional values.

Table 2-3, AC Grounding Electrode Conductor Sizing

Size of Largest Ungrounded Conductor	Minimum Size of Grounding Electrode Conductor
#2 AWG (33.6 mm ²) or smaller	#8 AWG (8.4 mm ²)
#1 (42.4 mm ²) to #1/0 AWG (53.5 mm ²)	#6 AWG (13.3 mm ²)
#2/0 (67.4 mm ²) or #3/0 AWG (85.0 mm ²)	#4 AWG (21.1 mm ²)
Over #3/0 AWG (85.0 mm ²) through 350 kcmil	#2 AWG (33.6 mm ²)

DC Side – To size the DC grounding electrode conductor, you must first determine which one of the following three methods will be used to connect the DC and AC grounding points in the inverter's two electrical systems to the common "earth" ground:

Method 1 (Figure 2-11): This method uses a separate grounding electrode for the DC system and the AC system. In this method—since there are multiple connections to the DC grounding electrode (GEC-DC)—the size of the DC grounding electrode conductor cannot be smaller than the largest conductor in the DC system (usually the battery-to-inverter cable).

The DC grounding electrode (GE-DC) must be bonded to the AC grounding electrode (GE-AC) to make a grounding system. This bonding conductor (BC) cannot be smaller than the largest grounding electrode conductor, either AC or DC.

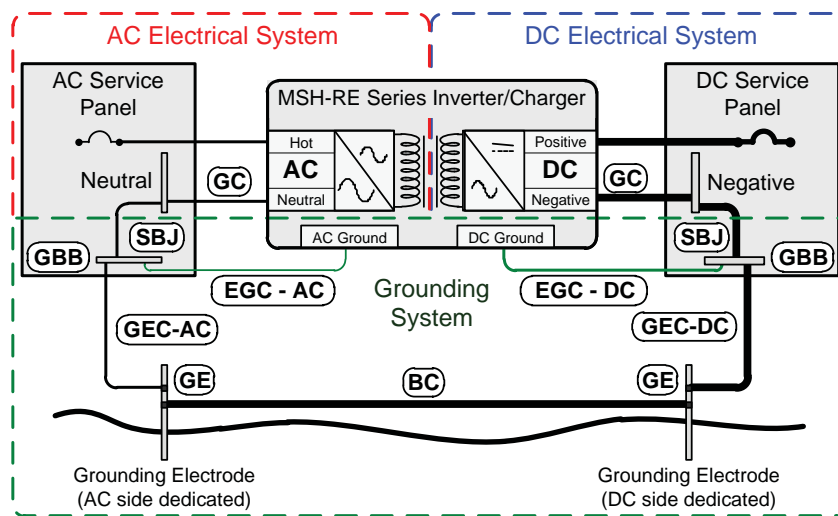

Figure 2-11, Multiple Connections to DC Ground Rod (Method 1)

Method 2 (Figure 2-12): When the AC and DC service panels are near each other, then the AC grounding electrode conductor (GEC-AC) and DC grounding electrode conductor (GEC-DC) can be connected to a single grounding electrode. In this method—since there are multiple connections to the DC grounding electrode (GEC-DC)—the size of the DC grounding electrode conductor cannot be smaller than the largest conductor in the DC system (usually the battery-to-inverter cable).

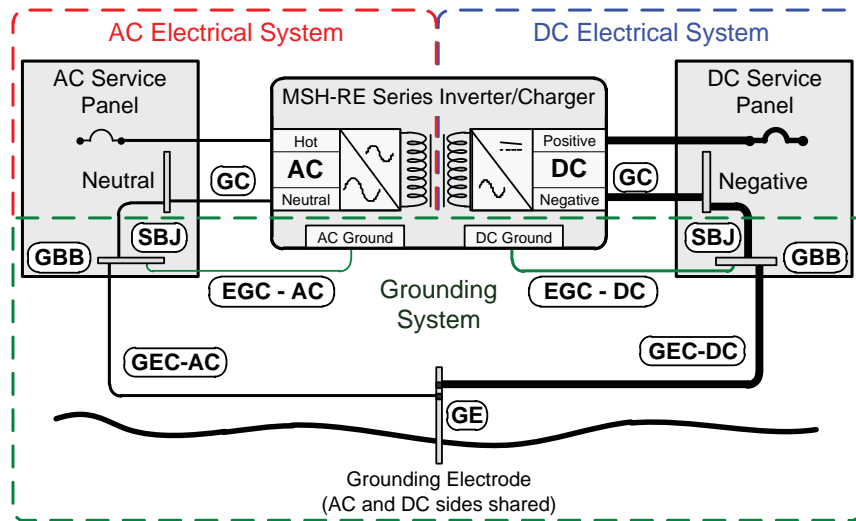

Figure 2-12, Multiple Connections to DC Ground Rod (Method 2)

Method 3 (Figure 2-13): The AC grounding electrode conductor (GEC-AC) is bonded to the DC ground point and the DC grounding electrode conductor (GEC-DC) is the *only connection* to the grounding electrode, which must be a rod, pipe, or plate electrode.

In this method, since there is only one connection to the ground rod, the DC grounding electrode conductor is not required to be larger than #6 AWG (13 mm²) copper. The reasoning for allowing this smaller grounding electrode conductor is that it is only required to stabilize the system voltage with respect to earth, and the other properly-sized conductors in each electrical system will safely carry any fault currents if they occur.

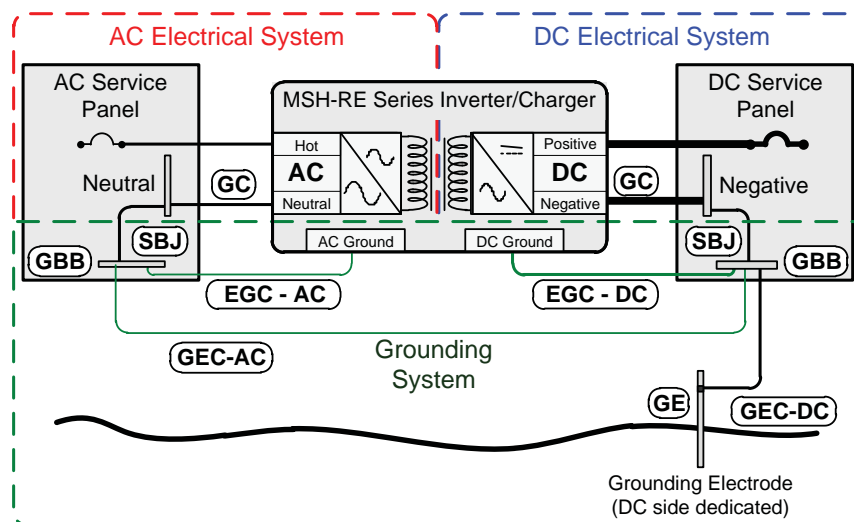

Figure 2-13, Single Connection to DC Ground Rod (Method 3)

Installation

2.6.2 System Bonding Jumper

The MSH-RE Series inverter does not include an internal bond between the grounded conductor (AC neutral/DC negative) and the equipment grounding terminals. This bond [system bonding jumper (SBJ)] is usually done in the main distribution panel for each electrical system.



CAUTION: There should be one and only one point in each electrical system (both AC and DC) where the grounded conductor is attached to the grounding electrode conductor.

AC Side – The size of the system bonding jumper (SBJ) in the AC electrical system is based on the area of the largest AC ungrounded conductor. In accordance with the NEC, use Table 2-4 to determine the system bonding jumper size compared to the largest AC ungrounded conductor.

DC Side – The size of the system bonding jumper (SBJ) in the DC electrical system must not be smaller than the DC grounding electrode conductor (GEC-DC) used, which is determined from the grounding method that will be used (see Section 2.6.1).

2.6.3 Equipment Grounding Conductor

The inverter case and all other noncurrent-carrying exposed metal surfaces in the entire electrical system that may be accidentally energized must be grounded. The equipment-grounding conductor must be sized to safely carry the maximum ground-fault current likely to be imposed on it from where a ground-fault may occur. In accordance with the NEC, use Table 2-4 to size the equipment-grounding conductors. This table requires that the equipment-grounding conductor be sized according to the rating of the overcurrent device protecting the circuit.



CAUTION: The connections and wiring for the equipment-grounding conductor must be continuous to allow fault currents to properly operate overcurrent devices. Where equipment is removed and this disconnects the bonding connection between the grounding electrode conductor and exposed conducting surfaces, a bonding jumper must be installed while the equipment is removed.

AC Side – Where the AC output from the inverter is connected to an AC load center, there should be an equipment grounding conductor connected between the inverter case and the grounding point in the AC load center. The AC equipment grounding conductor (EGC-AC) is sized per Table 2-4 and is connected to the inverter's AC equipment grounding terminal shown in Figure 2-8.

DC Side – Since the currents on the DC side are higher than the AC side (5 times at 24 volts), the equipment grounding needs are different. The DC equipment grounding conductor (EGC-DC) is sized per Table 2-4 and connected to the DC equipment grounding terminal on the inverter as shown in Item 7, Figure 1-2.

Table 2-4, Equipment Grounding Conductor Sizing

Rating of Overcurrent Device	Minimum Size of Copper Ground Wire
15 amps	#14 AWG (2.1 mm ²)
20 amps	#12 AWG (3.3 mm ²)
30 - 60 amps	#10 AWG (5.3 mm ²)
100 amps	#8 AWG (8.4 mm ²)
200 amps	#6 AWG (13.3 mm ²)
300 amps	#4 AWG (21.1 mm ²)
400 amps	#3 AWG (26.7 mm ²)

2.6.4 Connecting a Large DC Ground Wire

Some installations require the ground wire to be the same size or one size smaller than the negative cable. Use the following steps to allow a larger ground wire to be connected.

1. Locate and remove the AC access cover plate (Item 15, in Figure 1-3) on the inverter.
2. Locate the DC ground terminal (Item 7, in Figure 1-2).
3. Within the AC wiring area, locate the hex nut on the back side of the DC ground terminal. After locating the hex nut, use a 7/16" wrench/nut driver to remove the hex nut, bolt, lock washer, and DC ground terminal—remove them from the chassis.
4. Reverse the removed bolt and place it back in the chassis hole to attach a correctly sized ground cable to the inverter's chassis as shown in Figure 2-14.
5. Place the washer and nut on the bolt over the ground cable and securely tightened the nut [from 4 to 5 ft lbf (5.4 to 6.8 N-m)].

Note: The ground cable must have a hole size $\geq 1/4"$.

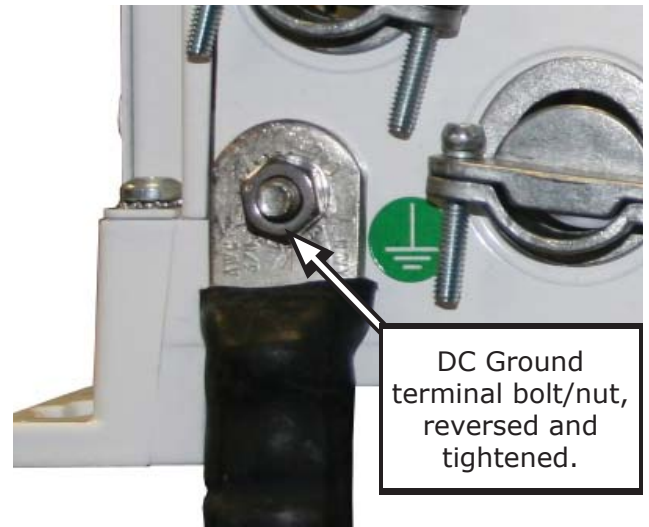

Figure 2-14, Large Ground Wire Connected to MSH-RE Series

2.7 Inverter Notification Requirements

When an inverter is installed in a building, facility or structure, the NEC (National Electrical Code) requires a label or plaque to be provided. This label/plaque is required to be easily visible and provide information that informs personnel on the location of all electrical system disconnects. This is to ensure all power to a building is quickly located and shut down in an emergency. There are also specific requirements for this label/plaque depending on the inverter application, they are as follows.

2.7.1 Facilities with Standalone Systems

Any building, facility, or structure with a photovoltaic power system that is not connected to a utility service source and is a standalone system must have a permanent plaque or directory installed on the exterior of the building or structure at a readily visible location acceptable to the Authority Having Jurisdiction (AHJ). The plaque or directory must provide the location of system disconnecting means and information regarding whether the structure contains a standalone electrical power system.

2.7.2 Facilities with Utility Services and PV Systems

Buildings, facilities, or structures with both utility service and a photovoltaic system must have a permanent plaque or directory providing the location of the service disconnecting means and the photovoltaic system disconnecting means if they are not in the same location.

Installation

2.7.3 Inverter Warning Label

A warning label as shown in Figure 2-15 is provided to inform all personnel that an inverter is installed in your electrical system. Affix this label in a clearly visible location at the electrical panel that is being powered by the inverter. This is because it might be falsely assumed that the panel is no longer "hot" after the AC power has been shut off, when power may actually still be available due to the inverter automatically powering the panel.

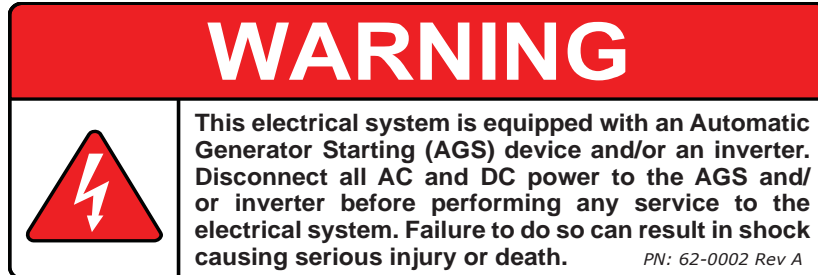

Figure 2-15, Warning Label

2.8 Final Inspection

1. Verify all cables/conduit runs are secured with wire ties or other non-conductive fasteners to prevent chafing or damage from movement and vibration.
2. Verify strain reliefs or grommets are in place to prevent damage to the wiring or conduit where it passes through walls, bulkheads, or other openings.
3. Verify all AC connections are correct and torqued to a maximum of 32 in lbf (3.6 N-m).
4. Replace the covers on the main electrical/distribution panel.
5. Replace the chassis access cover.
6. Verify the inverter's front panel switch is in the "OFF" position.



Info: If required by code, have the installation inspected by an electrical inspector.

2.9 Functional Test

After all electrical connections to the inverter, batteries, AC source and sub-panel have been completed, follow these steps to test the installation and the inverter's operation.



CAUTION: Use a multimeter to verify the correct DC voltage for your particular inverter model (i.e., 24-volt battery bank for a 24-volt inverter) and to ensure the polarity of the battery voltage is correct (battery positive connected to the inverter positive terminal and the battery negative connected to the inverter negative terminal).

1. Apply battery power to the inverter by closing the DC circuit breaker. The inverter will remain off, but the green status indicator on the front of the inverter will quickly blink once to indicate that DC power has been connected and the inverter is ready to be turned on.
2. Prior to turning on the inverter, make sure all AC loads (i.e., appliances) are NOT connected to the inverter's output or to any AC outlets powered by the inverter.
3. Lightly press and release the inverter's ON/OFF switch to turn the inverter on. Verify the inverter's status indicator is blinking—indicating the inverter is on.
4. Connect a 10-25 watt light bulb to the inverter output and verify it comes on and shines normally. DO NOT connect anything larger than a 25-watt light bulb until all wiring and voltages are confirmed to be correct.



Info: The inverter's AC output voltage will not be correct until a load greater than 5 watts (default setting) is connected to the inverter; or, Search mode is turned off with a remote display (ME-RC, ME-ARC, or ME-RTR). A 10-25 watt light bulb is used as it is a sufficient load to bring the inverter out of Search mode and up to full voltage.

5. Check the AC output voltage of the inverter by connecting an AC voltmeter to the output terminals as shown in Figure 2-16 (verify the correct output voltages).
6. Press and release the inverter's ON/OFF switch to turn the inverter off. The inverter's status indicator and the connected load should go off.
7. Apply AC power to the inverter's AC input. After the AC input power is qualified (approximately 15 seconds), the incoming AC power will transfer through the inverter to the inverter's AC output and power the light bulb. Verify that the inverter's status indicator and the light bulb come on.
8. Even though the light bulb is on, the inverter is currently disabled (off). Press and release the ON/OFF switch on the inverter to enable (turn on) the inverter.
9. Disconnect the incoming AC power to the inverter. Verify the light bulb remains on and is now powered by the inverter.

If the inverter passes all the steps, the inverter is ready for use. If the inverter fails any of the steps, refer to the Troubleshooting section in this manual.

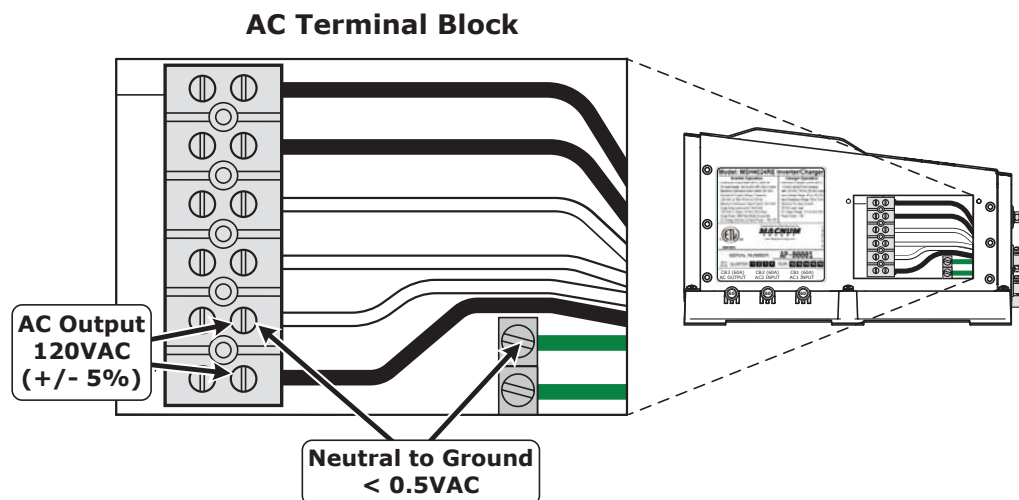

Figure 2-16, AC Voltage Checks

3.0 Operation

The MSH-RE Series inverter has two normal operating routines: Inverter mode, which powers your loads using the batteries, and Standby mode, which transfers the incoming AC current (i.e., utility power or a generator) to power your loads and to recharge the batteries. This inverter also includes an extensive protection circuitry to shut down the inverter under certain fault conditions.

3.1 Inverter Mode

When the MSH-RE Series is first powered up, it defaults to the OFF mode. The momentary ON/OFF power switch (Item 1, Figure 1-1) must be lightly pressed to turn the inverter on. Subsequently pressing this switch alternately turns the inverter off and on.

Inverter OFF – When the inverter is off, no power is used from the batteries to power the AC loads, and the status LED will be off. If AC power from an external source (utility grid or generator) is connected and qualified on the inverter’s AC input, this AC input power will pass through the inverter to power the AC loads. However, if this AC power is lost, the AC loads will no longer be powered because the inverter is off.

When the inverter is turned on, it operates either by “searching” or “inverting”, depending on the connected AC loads.

Searching – When the inverter is first turned on, the automatic Search feature is enabled. This feature is provided to conserve battery power when AC power is not required. In this mode, the inverter pulses the AC output looking for an AC load (i.e., electrical appliance). Whenever an AC load (greater than 5 watts) is turned on, the inverter recognizes the need for power and automatically starts inverting. When there is no load (or less than 5 watts) detected, the inverter automatically goes back into Search mode to minimize energy consumption from the battery bank. When the inverter is searching, the inverter’s green LED flashes (fast).



Info: The factory default value for the Search feature is 5 watts. It can be turned off or adjusted from 5 to 50 watts using a remote display (ME-RC, ME-ARC, or ME-RTR).

Inverting – When a load greater than 5 watts is connected to the inverter output, the MSH-RE Series inverts the DC power from the battery and supplies 120 VAC power to your sub-panel. The inverter’s green LED flashes once every 2 seconds (medium flash) to indicate it is inverting. The amount of time the inverter can be inverting and providing power is directly related to the amount of AC loads that are connected, and the capacity of the battery bank. Refer to Figure 3-1 to see the flow of power (GRID and GEN) from the DC input to the AC output while in the Inverter mode.

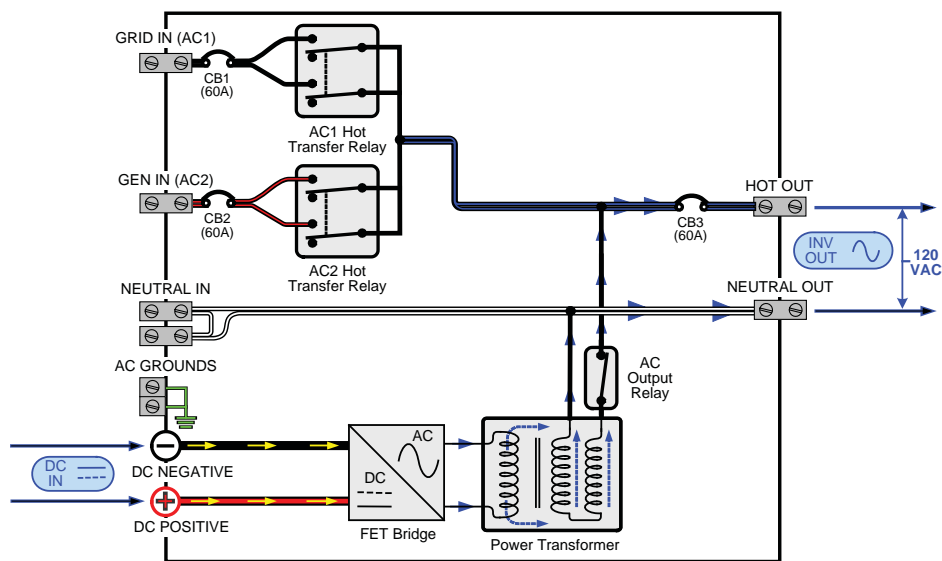

Figure 3-1, Power Flow – Inverter Mode

3.2 Standby Mode

The MSH-RE Series features an internal battery charger and an automatic transfer relay when operating in Standby mode. The Standby mode begins whenever AC power (utility grid or generator) is connected to the inverter's AC input. Once the AC voltage and frequency of the incoming AC power is within the AC input limits, an automatic AC transfer relay is activated. This transfer relay passes the incoming AC power through the inverter to power the AC loads on the inverter's output. This incoming power is also used to activate a powerful internal battery charger to keep the battery bank charged in case of a power failure. Refer to Figures 3-2 (GRID) and 3-3 (GEN) to see the flow of power from the AC input to the DC and AC output while in Standby mode.

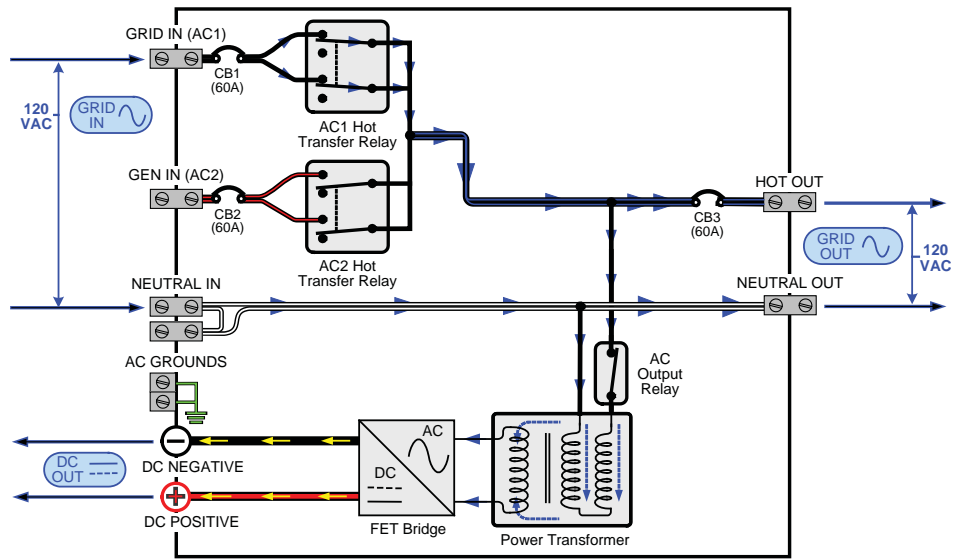

Figure 3-2, Power Flow – Standby Mode (GRID Input)

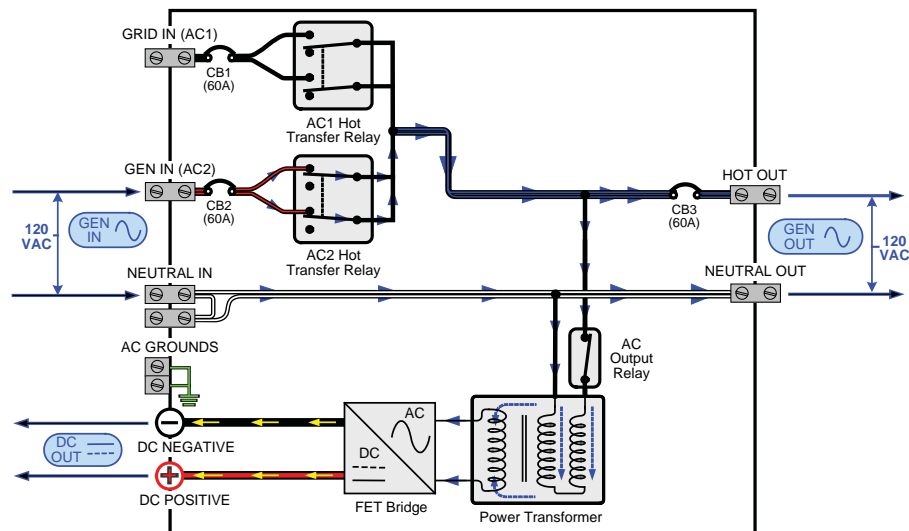

Figure 3-3, Power Flow – Standby Mode (GEN Input)

3.2.1 Battery Charging

Magnum Energy's MSH-RE Series is equipped with an active PFC (Power Factor Corrected) and PI (Proportional-Integral) multi-stage battery charger. The PFC feature controls the amount of power used to charge the batteries in order to obtain a power factor as close as possible to 1 (or unity). This causes the battery charger to look like a resistor to the line (forces the charge current wave shape to mirror the voltage wave shape). The PI feature allows the charger voltage and current to change independently. These two features maximize the real power available from either the utility or generator AC power sources, which translates into less power wasted and greater charging capabilities than most chargers available today.

When an AC source is connected to the AC input, the inverter begins monitoring for acceptable AC voltage. Once the inverter has accepted this AC voltage, the AC transfer relay closes and Charge mode begins. After Charge mode begins, the DC voltage is monitored to determine the charging stage. If the DC voltage is low (≤ 25.6 VDC), the charger begins Bulk charging. If the DC voltage is high (> 25.6 VDC), the charger will skip the Bulk and Absorb charging stages and go directly to Float charging. The multi-stage charger can use up to five different charging stages to help monitor and keep the batteries healthy. The five stages include an automatic 4-stage charging process: Bulk, Absorb, Float, and Full Charge; and a manual Equalization (EQ) charge stage. The automatic 4-stage charge process provides complete recharging and monitoring of the batteries without damage due to overcharging. The EQ stage (requires a remote display to enable) is used to stir up stratified electrolyte and to reverse any battery plate sulfation that may have occurred.

While charging, the unit may go into charger back-off protection, which automatically reduces the charge current to the batteries. This is caused by: 1) The internal temperature is too hot—the charger automatically reduces the charge rate to maintain temperature; or 2) The AC input voltage falls below 90 VAC—the charger stops charging to help stabilize the incoming AC voltage.

The Charge mode provides up to four separate charging stages: Bulk Charging, Absorb Charging, Float Charging and Full Charge.

Bulk Charging: This is the initial stage of charging. While bulk charging, the charger supplies the battery with controlled constant current. The charger will remain in bulk charge until the absorption charge voltage (determined by the Battery Type selection*) is achieved. The inverter's green LED stays ON (solid) to indicate bulk charging.

Absorb Charging: This is the second charging stage and begins after the absorb voltage has been reached. Absorb charging provides the batteries with a constant voltage and reduces the DC charging current in order to maintain the absorb voltage setting. The inverter's green LED flashes once every second (fast flash) to indicate absorption charging for 2 hours (determined by the Battery AmpHrs selection*), then switches to float charging.

Float Charging: The third charging stage occurs at the end of the absorb charging time. While float charging, the charge voltage is reduced to the float charge voltage (determined by the Battery Type selection*). In this stage, the batteries are kept fully charged and ready if needed by the inverter. The inverter's green LED flashes once every 8 seconds (slow flash) to indicate float charging. The Float Charging stage reduces battery gassing, minimizes watering requirements (for flooded batteries), and ensures the batteries are maintained at optimum capacity.

Full Charge (Battery Saver™ mode): The fourth stage occurs after four hours in the Float Charging stage. The Full Charge stage is designed to keep batteries fully charged over long periods, and to prevent excessive loss of water in flooded batteries or drying out of GEL/AGM batteries. In this stage, the charger is turned off and begins monitoring the battery voltage; if the battery voltage drops low (12.7 VDC or less on 12-volt models or 25.4 VDC or less on 24-volt models), the charger automatically initiates another four hours in float charge.



Info: If the battery voltage falls to the re-bulk voltage (24.2 VDC) or lower, the unit will begin another bulk charge.

* *These settings in the MSH-RE are changeable and leave the factory with default values (see Table 3-2, Inverter/Charger Default Values). These default values are adequate for most installations, however, a remote control (ME-RC, ME-ARC, or ME-RTR) may be purchased to adjust these settings.*

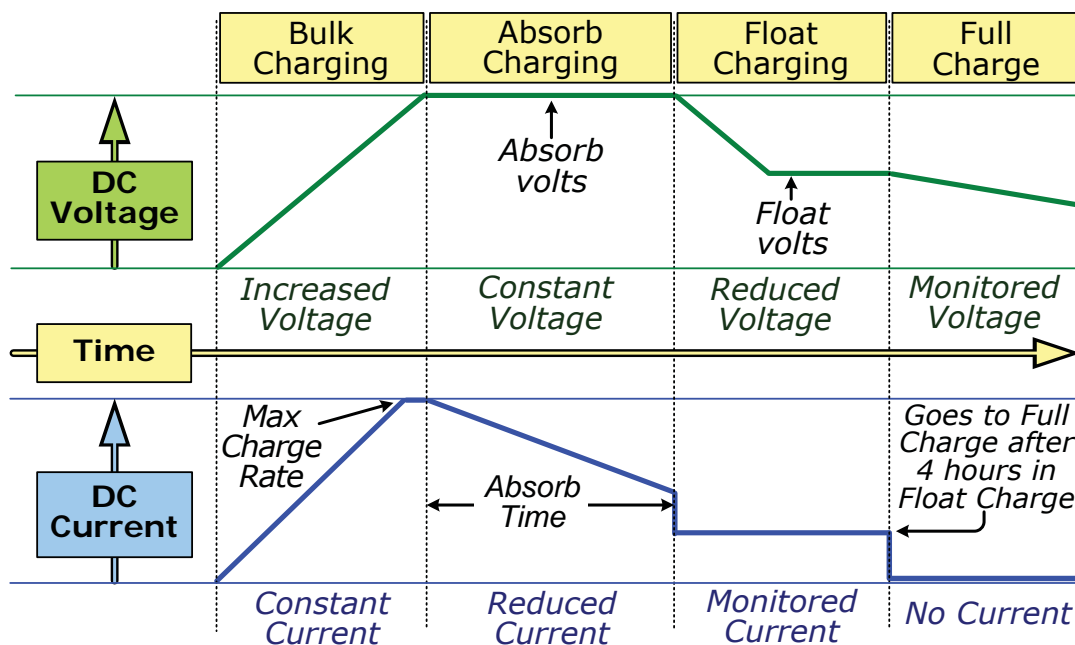

Figure 3-4, Automatic 4-Stage Charging Graph

3.2.2 Load Support

While in the Standby Mode and the charger is enabled, the MSH-RE Series inverter/charger has the ability to work in parallel with the incoming AC source to support the AC loads using current from the batteries. During the Standby mode, the current and voltage from the AC source and the AC load current are continually monitored. When loads that exceed the available current from either the utility grid or the generator are connected, the Load Support feature is automatically activated. The Load Support feature causes the MSH-RE inverter/charger to reduce/stop the battery charging operation and to begin the inverting operation to allow any available current from the batteries to be used to ensure the AC loads are powered and the current does not exceed the capacity of the AC source, or trip its output breakers or fuses. The Load Support feature turns off once the load demand decreases and spare power from the incoming AC source is available; when this happens, the battery charger is again activated and begins charging the batteries.

For the Load Support feature to automatically function, the following needs to occur:

1. An AC source (utility grid/AC generator) must be connected.
2. The inverter must be enabled (INV LED is on).
3. The battery voltage must be ≥ 0.5 volts (for a 12-volt system) or ≥ 1.0 volts (for a 24-volt system) than the LBCO setting.



Info: If using a remote and the unit is in load support, the status will display as "Load Support AAC" or "Load Support VDC".

There are two modes of operation within Load Support.

- **Load Support AAC** – In this mode, the AC loads connected are requiring more power than the incoming AC source can provide on its own. The inverter pulls the additional current—that is needed for the loads—from the inverter batteries to keep the incoming AC current from exceeding the input amps setting on the remote control.



Info: In Load Support AAC, even though the LED indicators may indicate charging, the inverter/charger may not be putting current into the battery. If using a remote, the inverter/charger amps AC meter will indicate the load support process by displaying negative current flowing from the batteries to the loads. The input amps AC will also drop during this process, while the load amps AC remains the same.

Operation

- **Load Support VDC** – In this mode, an external DC source (i.e., solar, hydro, wind, etc.,) is providing more current than needed, causing the battery bank voltage to rise. The inverter/charger reduces the incoming AC current and uses current from the batteries in an effort to keep the battery voltage from rising above the temperature-compensated battery type setting on the remote control.



Info: The charger must be enabled (not in Charger Standby) and in the Absorb, Float, or EQ charge modes in order for the Load Support VDC feature to be active.

3.3 Current Flow

The following figures show the current flow in the MSH-RE Series during different modes:

Inverting – The MSH inverter converts the current from the battery to power the AC loads.

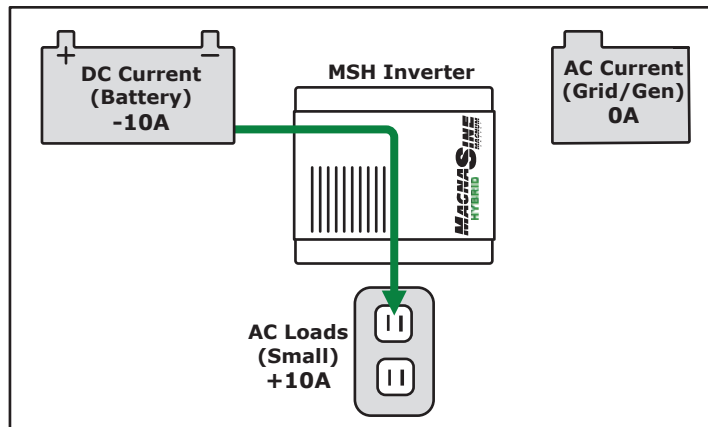

Figure 3-5, MSH Current Flow – Inverting

Charging and AC pass-thru – The MSH-RE inverter uses current from the grid/generator to power the AC loads, and also converts this current to charge the battery.

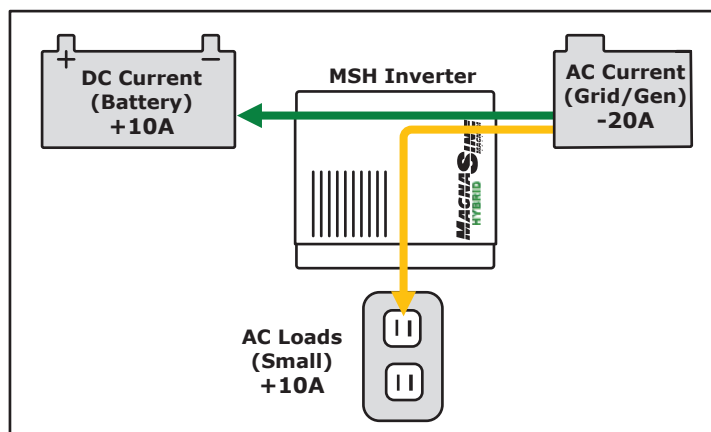

Figure 3-6, MSH Current Flow – Charging and AC Pass-thru

Charger Back-off – When the AC loads increase, the MSH-RE inverter reduces or stops the battery charge current to allow the grid/generator to continue powering the AC loads.

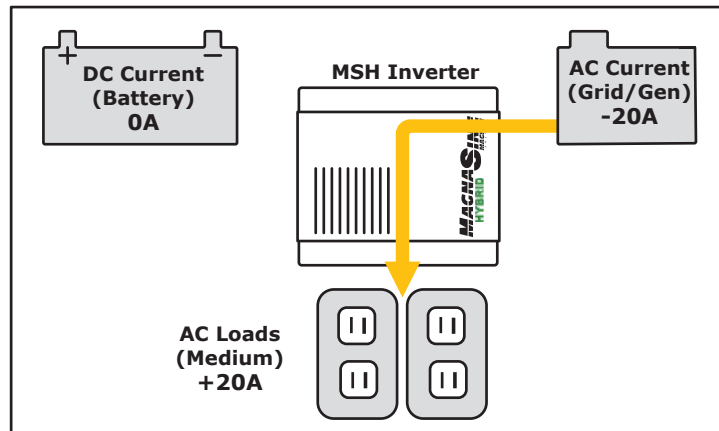

Figure 3-7, MSH Current Flow – Charger Back-off

Load Support AAC – If AC loads are added that are above the capability of the grid/generator, the MSH converts current from the battery and combines it with the current from the grid/generator to power the additional AC loads.

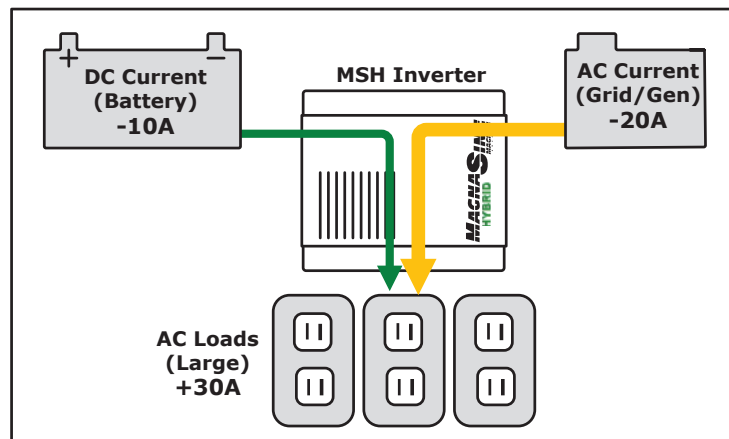

Figure 3-8, MSH Current Flow – Load Support AAC

Load Support VDC – If the battery is being charged externally (i.e., solar, wind, or hydro), the MSH converts any excess current from the battery to power the AC loads and reduce the current from the grid/generator.

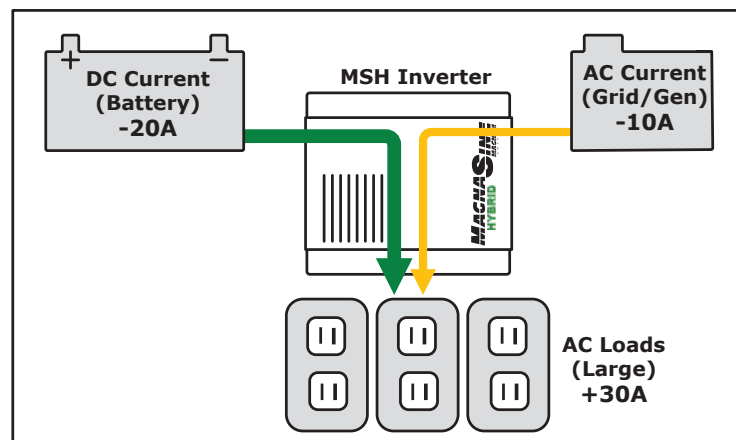

Figure 3-9, MSH Current Flow – Load Support VDC

Operation

3.4 Transfer Time

While in Standby mode, the AC input is continually monitored. Whenever AC power falls below the VAC dropout voltage (80 VAC, default setting), the inverter automatically transfers back to Inverter mode with minimum interruption to your appliances—as long as the inverter is turned on. The transfer from Standby mode to Inverter mode occurs in approximately 16 milliseconds. While the MSH-RE Series is not designed as a computer UPS system, this transfer time is usually fast enough to hold them up. However, the VAC dropout setting has an effect on the ability of the loads to transfer without resetting. The lower this setting, the longer the effective transfer will be and therefore, the higher the probability for the output loads to reset. This occurs because the incoming AC voltage is allowed to fall to a level that is so low that when the transfer does occur, the voltage on the inverter's output has already fallen low enough to reset the loads.

The disadvantage of a higher VAC dropout setting is that smaller generators (or large generators with an unstable output) may nuisance transfer. This commonly happens when powering loads that are larger than the generator can handle—causing the generator's output voltage to constantly fall below the inverter's input VAC dropout threshold.



Info: When switching from Inverter mode to Standby mode, the inverter waits approximately 15 seconds to ensure the AC source is stable before transferring.

3.5 Battery Temperature Sensor Operation

The plug-in Battery Temperature Sensor (BTS) is used to determine the battery's temperature. This information allows the multi-stage battery charger to automatically adjust the battery charge voltages for optimum charging performance and longer battery life.

With a BTS installed, if the temperature around the BTS is below 77°F (25°C) the absorb and float charge voltage increases, and if the temperature around the BTS is higher than 77°F (25°C), the absorb and float charge voltage decreases. See Figure 3-10 to determine how much the charge voltage changes (increases or decreases) depending on the temperature reading of the BTS. For example, the nominal absorb charge voltage for a flooded battery at 77°F (25°C) on a 24-volt model is 29.2 VDC. If the battery temperature is 95°F (35°C), the absorb charge voltage would decrease to 28.6 VDC (29.2 VDC - 0.6 change).

If the temperature sensor is NOT installed, the charge voltages will not be compensated and charges at a temperature of 77°F (25°C). The life of the batteries may be reduced if they are subjected to large temperature changes when the BTS is not installed.



Info: When the BTS is connected, the battery charger uses a value of -5mV/°C/Cell from 0-50°C to change the charge voltage based on temperature.

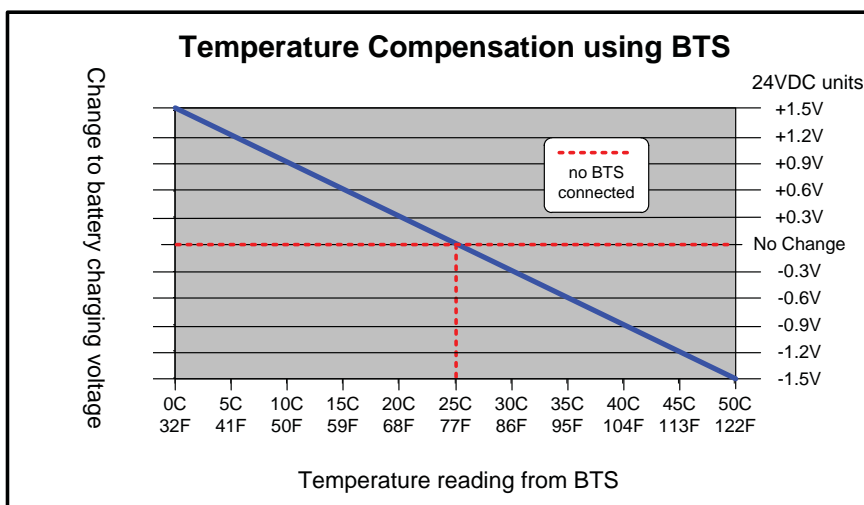

Figure 3-10, BTS Temperature to Charge Voltage Change

3.6 Protection Circuitry Operation

The inverter is protected against fault conditions and in normal usage it will be rare to see any. However, if a condition occurs that is outside the inverter’s normal operating parameters, then it will shut down and attempt to protect itself, the battery bank, and your AC loads. If there is a condition that causes the inverter to shut down, it may be one of the following conditions [also refer to the Troubleshooting section (Section 4.2) to help diagnose and clear the fault condition].

- **Low Battery** – The inverter will shut off whenever the battery voltage falls to the **LBCO** (Low Battery Cut Out) level to protect the batteries from being over-discharged. After the inverter has reached the LBCO level and turned off, the inverter will automatically restart after one of the following conditions:
 1. AC power is applied and the inverter begins operating as a battery charger.
 2. Battery voltage rises to the **LBCI** (Low Battery Cut In) level.

The inverter’s status LED turns off when a low battery fault condition occurs. Refer to Table 3-1 to determine the LBCO and LBCI levels for your inverter model.

- **High Battery** – In the event the battery voltage approaches the **HBCO** (High Battery Cut Out) level, the inverter will automatically shut down to prevent the inverter from supplying unregulated AC output voltage. The inverter’s status LED turns off when a high battery fault condition occurs. The inverter will automatically restart when the battery falls to the **HBCI** (High Battery Cut In) level. Refer to Table 3-1 to determine the HBCO and HBCI levels for your inverter model.



Info: High battery voltage may be caused by excessive or unregulated voltage from the solar panels or other external charging sources.

- **Overload** – During inverter and standby operation, the inverter monitors the DC and AC current levels. In the event of a short-circuit or an overload condition for more than a few seconds, the inverter will shut down. To start operating after this fault, the inverter must be restarted (turned back on) once the inverter’s AC loads are reduced/removed.
- **Over-temperature** – If internal power components begin to exceed their safe operating temperature level, the inverter will shut down to protect itself from damage. The inverter’s status LED turns off to indicate the over-temperature fault condition. The inverter automatically restarts after the unit cools down.
- **Internal Fault** – The inverter continually monitors several internal components and the processor communications. If a condition occurs that does not allow proper internal operation, the inverter will shut down to protect itself and the connected loads. The inverter will need to be reset to start operating—refer to Section 4.3 for information on resetting the inverter.

Table 3-1, Inverter Battery Turn On/Off Levels

Inverter battery turn ON/OFF Levels	Inverter Model
	MSH4024RE
HBCO	>33.8 VDC
HBCI	33.2 VDC
LBCI	25.0 VDC
LBCO* (1 minute delay)	20.0 VDC (18.0 - 24.4 VDC)
LBCO (immediate)	17.0 VDC

**adjustable with remote control*

Operation

3.7 Inverter Startup

ON/OFF Switch – The inverter can be turned on and off by lightly pressing and releasing the Power ON/OFF switch on the front of the inverter (refer to Figure 3-11). When the inverter is first connected to the batteries, or when its automatic protection circuit has turned the inverter off, the ON/OFF switch will need to be pressed to start the unit (or reset per Section 4.3). Once the inverter has been turned on, pressing the Power ON/OFF switch alternately turns the inverter on and off.



WARNING: The Power ON/OFF switch does not turn on or off the charger feature or remove pass-thru power. If AC power (utility or generator) is connected and qualified on the AC input, this AC power will also be available on the AC output and is not controlled by the Power ON/OFF switch.

Status LED Indicator – The status indicator is a green LED (Light Emitting Diode) that provides information on the operational mode of the inverter. Watch this indicator (refer to Figure 3-11) for at least 10 seconds to determine the inverter's operational condition from the information below:

- **Off** – Indicates the inverter is off; there is no AC power (inverter, utility, or generator) at the inverter's output terminals. If the LED stays off after pressing the ON/OFF switch, there is a fault condition such as: low battery, high battery, overload, over-temperature, or an internal fault. Refer to the Troubleshooting section to help diagnose the fault condition.
- **Slow Flash On** (blinks on for 4 seconds, then off for 4 seconds) – Indicates float charging, and the inverter is in Standby mode (the external AC power that is connected to the inverter's input is passing through the inverter and powering the inverter's AC loads).
- **Medium Flash On** (blinks on once every second):
When AC power is not connected to inverter input – Indicates the inverter is on and using energy from the battery. The inverter is either: 1) Inverting – providing full power to the inverter loads; or 2) Searching – conserving power and waiting for a load to be turned on that meets or exceeds the Search Watts parameter (5 watts is the inverter default setting).
When AC power is connected to inverter input – Indicates absorb charging, and the inverter is in Standby mode (the external AC power that is connected to the inverter's input is passing through the inverter and powering the AC loads on the inverter's output).
- **Fast Flash On** (blinks very quickly—flutters) – Indicates the inverter is in equalize charge (requires remote to enable) or the inverter is continuously in reset. If a remote was not used to enable the equalize charge, then suspect the inverter is in reset. Refer to the Troubleshooting section to help diagnose the fault condition.
- **On (solid)** – Indicates bulk charging, and the inverter is in Standby mode (the external AC power that is connected to the inverter's input is passing through the inverter and is powering the AC loads connected to the inverter's output).

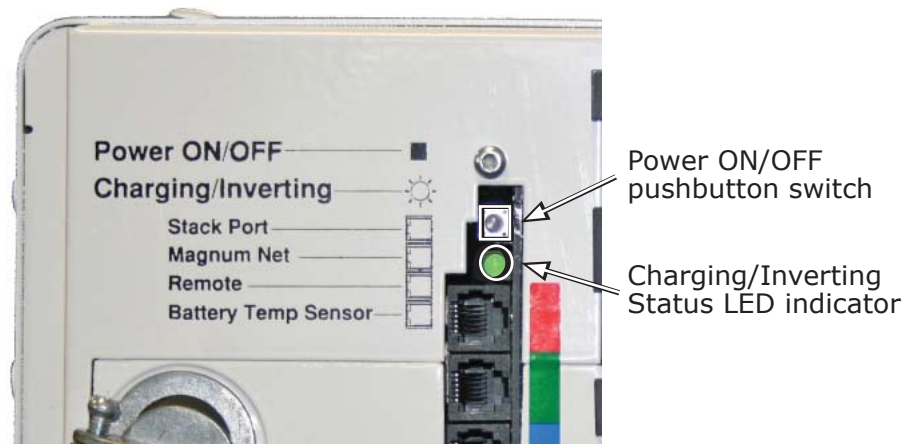

Figure 3-11, Power Switch and Status Indicator

3.8 Factory Default Values

Your MSH-RE Series inverter/charger uses default values for the adjustable settings (shown in Table 3-2) that are adequate for most installations. If some of your operating parameters need to be changed from the default values, an optional remote display can be used to make those changes. To help you determine if you need a remote display, information on the inverter/charger settings that can be changed is provided below. Once programmed, the settings are saved in the remote’s non-volatile memory and are preserved until changed—even if DC power to the inverter is lost (as long as the remote display is connected). For information on the full range of settings for each function in your remote display, refer to its owner’s manual at www.magnumenergy.com.

- **Shore Max/Input Amps:** This setting ensures the inverter AC loads receive the maximum current available from the utility or generator power. When the total current used to power the AC loads and charge the batteries begins to approach the *Shore Max* setting, the current that was used for charging the batteries will automatically be reduced.
- **Search Watts:** This setting allows you to turn off the power-saving Search mode circuitry, or to adjust the power level at which the inverter will “wake up” and start inverting.
- **LowBattCutOut:** This setting determines when the inverter will turn off based on low battery voltage. The inverter turns off automatically after the battery voltage has been below this setting for more than one minute. This protects the batteries from over-discharge and the AC loads from unregulated power (brown-outs).
- **Absorption Time:** This setting allows the user to determine how long to charge the batteries in the Absorb Charge stage.
- **Battery Type:** Sets the type of batteries being used in the system. This information tells the charger what voltage level to use to charge the batteries.
- **Charge Rate:** This setting can be used to turn off the charger, limit the amount of current that the charger can use (leaving more current available to power loads), or to ensure small battery banks are not overheated because of a charge rate that is too high.
- **VAC Dropout:** Sets the minimum AC voltage that must be present on the AC input before the unit transfers from Standby mode to Inverter mode. This protects the AC loads from utility outages and brown-outs.

Using a remote display also provides the following features:

- allows you to enable an equalize charge for certain battery types
- displays inverter/charger’s operating status
- provides fault information for troubleshooting



Info: Specific adjustments that are set using a remote control will be LOST if the remote is unplugged and battery power is shut off to the inverter/charger.

The table below provides the inverter’s default settings—without a remote connected.

Table 3-2, Inverter/Charger Default Values

Adjustable Settings	Default Values
Shore Max/Input Amps	30 Amps
Search Watts	5 Watts
LowBattCutOut	20 VDC (one minute delay) 17 VDC (no delay)
Absorption Time	600 Amp Hours (Absorb Time = 120 minutes)
Battery Type	Flooded – Liquid Lead Acid
Charge Rate	100%
VAC Dropout	80 VAC

Operation

3.9 Inverter Fan Operation

The inverter contains two internal cooling fans that are automatically controlled. The speed of these fans is determined either by the internal temperature of the inverter or by the load on the inverter. The inverter's fans will come on under the conditions listed below:

- Fans run full speed if the internal transistors (FETS) or the power transformer reaches 80°C (176°F), or the inverter is running at 100% of its rated load.
- Fans run medium speed if the internal transistors (FETS) or the power transformer reaches 60°C (140°F), or the inverter is running at 50% of its rated load.
- Fans run low speed when the inverter is running at 25% of its rated load.

The fans shut down when none of the above conditions are met, or if the battery voltage is below 19.0V (24-volt systems).

Whenever the inverter is first connected to the battery, the fans start for about 1 second. The inverter's fans will not start based on temperature sensed by the optional BTS.

3.10 Using a Remote with the MSH-RE Series Inverter

The MSH-RE Series inverter—connected to a ME-ARC remote control—has many advanced features. The inverter and remote communicate with each other to allow these advanced features to be set up or enabled. However, the remote may have a later/newer software revision than the inverter, so some of the features and functionality in the remote may not be available with your inverter. Use the steps below to determine what remote menus/features are available with your inverter:

1. Obtain your inverter's software revision.
Note: To view the inverter's software revision level, push the TECH button on your ME-ARC remote and access the Revisions menu.
2. Use the chart below to determine the inverter's compatibility level (L1, L2, L3 or L4) based on your inverter's software revision.

Table 3-3, Inverter Compatibility Level

INV/CHG Models	Level 1 (L1)	Level 2 (L2)	Level 3 (L3)	Level 4 (L4)
MSH4024RE	NA	NA	NA	≥ Rev 1.1

3. After determining the inverter's compatibility level, refer to the remote's compatibility matrix (find it online at: www.magnumenergy.com under the Service and Support tab) to determine which remote features/settings you can use based on your inverter's compatibility level.

Note: If your inverter's compatibility level is the same or greater than the 'Inverter Model/Level Required' on the remote compatibility matrix on our website, then your inverter can support the device setting/feature you want. If your inverter does not have the required compatibility level for a feature/setting you want, contact Magnum Energy about a software upgrade.

3.10.1 Remote Compatibility

The MSH-RE Series inverter/charger provides the Load Support feature and has two independent AC source inputs (AC1/GRID, AC2/GEN) with independent AC input amps and VAC dropout settings, and AC meters for each input. Older remote revisions will work with the MSH-RE Series. However, to view the Load Support status and to monitor and allow independent AC input settings, the following remote revisions are required.

Table 3-4, Remote Compatibility Level

Remote Models	Revision Required
ME-RC	≥ Revision 2.7 Shows Load Support status and AC meters for each input; however, the input settings are combined.
ME-ARC	≥ Revision 3.0
ME-RTR	≥ Revision 3.0

4.0 Maintenance and Troubleshooting

The following information is provided to help you keep your MSH-RE Series inverter/charger in optimum operational condition.

4.1 Recommended Inverter and Battery Care

The MSH-RE Series inverter/charger is designed to provide you with years of trouble-free service. Even though there are no user-serviceable parts, it is recommended that every 6 months you perform the following maintenance steps to ensure optimum performance and extend the life of your batteries.



WARNING: Prior to performing any checks, switch off the AC and DC circuits.

- Visually inspect the batteries for cracks, leaks, or swelling—replace if necessary
- Use baking soda to clean and remove any electrolyte spills or buildups
- Check and tighten all battery hold-down clamps (if applicable)
- Clean and tighten all battery terminals and connecting cables [10 to 12 ft lbf (13.6 to 16.3 N-m)]
- Check and fill battery water levels (liquid lead acid batteries only)
- Check individual battery voltages (load test those that have a voltage difference of more than 0.3 VDC from each other)—replace if necessary
- Check all cable runs for signs of chafing—replace if necessary
- Check the inverter's cooling vents—clean as necessary
- Check/tighten the inverter's internal AC terminal block connections [32 in lbf (3.6 N-m)]



WARNING: If an automatic generator start device were to start and run the generator for an extended period of time in a confined area, a potentially fatal level of CO (carbon monoxide) could accumulate.

Maintenance and Troubleshooting

4.2 Troubleshooting

The MSH-RE Series inverter/charger is a fairly simple device to troubleshoot. There are only two active circuits (AC and DC) as well as a charging circuit. The following chart is designed to help you quickly pinpoint the most common inverter failures.

Table 4-1, Basic Inverter Troubleshooting (Remote not available)

Symptom	Possible Cause	Recommended Solution
No output power. Inverter LED is off.	Inverter is switched off.	Switch the inverter on.
	Battery voltage is too low. The battery voltage level has dropped below the Low Battery Cutout (LBCO) set-point for more than one minute.	Check fuses/circuit-breakers and cable connections. Check battery voltage at the inverter's terminals. Your batteries may need to be charged, this fault condition will automatically clear when the battery voltage exceeds the LBCI voltage.
	The battery voltage is too high. The inverter automatically resets and resumes operation when the battery voltage drops to the HBCI voltage or lower.	This condition usually only occurs when an additional charging source (alternator, solar panels, or other external charging sources) is used to charge the battery bank. Reduce or turn off any other charger to the inverter batteries to allow the voltage level to drop.
	Over-temperature condition: the internal temperature of the inverter has risen above acceptable limits; caused by loads too great for the inverter to operate continuously, or by lack of ventilation to the inverter. When the unit has cooled, it will automatically reset and resume operation.	Reduce the number of electrical loads that you are operating, this will avoid a repeat over-temp shutdown if the cause was too many loads for the ambient conditions.
		Check ventilation around the inverter, ensure cool air is available to pass through the inverter (refer to the ventilation requirements in Section 2.1.3).
	AC overload condition: the inverter has turned off because the connected loads are larger than the inverter's output capacity, or the output wires are shorted.	Reduce the AC loads connected to the inverter, or remove all AC output wiring and restart the inverter.
Internal fault: this fault occurs when an internal fault is detected.	To clear this fault, an inverter reset is required, see Section 4.3 to perform an inverter reset.	
No output power. Green LED is flashing ON once every second.	Unit is in Search mode, which means load is too small for Search mode circuit detection.	Turn on a load greater than 5 watts to bring inverter to full output power.
No output power. Green LED is flashing very quickly – fluttering.	Unit is in continuous reset.	Check that the inverter Power ON/OFF switch is not stuck in the ON position (ensure you can feel a click when pushing). If not, the inverter requires repair/service.
Low output or surge power. Green LED is flashing.	Loose or corroded battery cables.	Clean and tighten all cables.
	Low batteries.	Recharge or replace batteries.
	Loose AC output connections.	Tighten AC output connections.
	Battery cables are the wrong length or gauge.	Verify recommended cable lengths and gauges from the manual. Replace cables as necessary.
Low charging rate when connected to AC power.	Charge rate backing off due to high temperature inside inverter.	Provide better inverter ventilation/cooling or additional battery chargers may be needed if battery bank is very large.
	Low AC input voltage (<90 VAC).	Check AC input wiring.
Low charging rate when using a generator.	Generator output is too low to power both load and charger.	Reduce the load, increase the generator's RPMs.
Charger does not charge.	Loose or corroded battery cables.	Clean and tighten battery cables.
	Defective batteries.	Replace batteries.
	Wrong AC input voltage.	Verify proper AC input voltage and frequency.
While charging, the DC charge voltage is higher or lower than expected.	If the Battery Temperature Sensor (BTS) is installed, the DC voltage will increase or decrease depending on the temperature around the BTS.	This is normal; see Section 3.5 (Battery Temperature Sensor Operation) for more information.

4.3 Performing an Inverter Reset

To perform an inverter reset (also known as a “soft reset”):

1. First ensure all AC power (i.e., shorepower or generator) is removed from the inverter’s input.
2. Press and hold the Power ON/OFF pushbutton (see Figure 4-1) for approximately ten (10) seconds until the Charging/Inverting Status LED comes on and flashes rapidly.
3. Once the rapid flashing has begun, release the Power ON/OFF pushbutton. The Status LED will go off after the button is released.
4. After the inverter reset is completed, press the Power ON/OFF pushbutton to turn on the inverter.

Some older inverter models do not allow an inverter reset. If the inverter reset fails, you will need to perform a power reset using the procedure below. In either case, if an internal fault does not clear, the inverter will require repair at a Magnum Authorized Service Center (ASC).



Info: The Power ON/OFF pushbutton is a small *momentary* type switch which operates by lightly pressing and releasing. Be careful not to apply too much force when pushing or the switch might break.

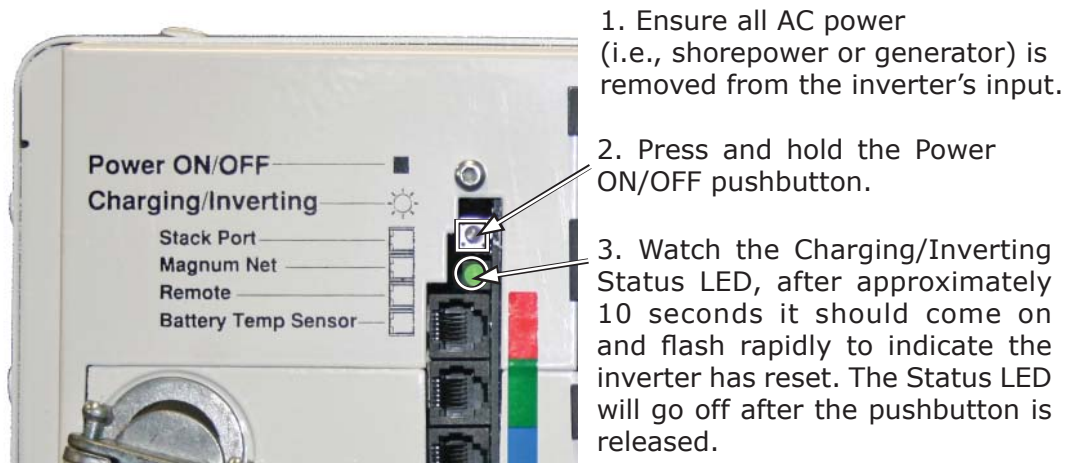

Figure 4-1, Power Reset

4.4 Performing a Power Reset

To perform a power reset (also known as a “hard reset”):

1. Remove all AC power (utility or generator power) to the inverter.
2. Open all the inverter DC disconnects (or disconnect the positive battery cable to the inverter).
3. Ensure the inverter and the remote are disconnected from all AC and DC power (the remote display will be blank).
4. After the inverter has been disconnected from all power for 30 seconds, reconnect the inverter DC disconnects (or reconnect the positive battery cable) and resume operation.



Info: If DC disconnects are not used, there may be a momentary spark when the positive battery cable is connected to the inverter’s terminal. This is normal and indicates that the inverter’s internal capacitors are being charged.

Appendix A – Specifications

Appendix A – Specifications and Optional Equipment

A-1 Inverter/Charger Specifications

Model	MSH4024RE
Inverter Specifications	
Input battery voltage range	18.0 to 34.0 VDC
Absolute maximum DC input	35 VDC
AC output voltage accuracy	120 VAC $\pm 3\%$ (\leq continuous power)
Output frequency and accuracy	60 Hz \pm 0.05 Hz
Total Harmonic Distortion (THD)	< 5%
Continuous power output (at 25°C)	4000 VA
Continuous AC output current	33 A
1 msec surge current (amps AC)	120
100 msec surge current (amps AC)	72
5 sec surge power (real watts)	5800
30 sec surge power (real watts)	5400
5 min surge power (real watts)	4900
30 min surge power (real watts)	4500
Maximum continuous input current	267 ADC
Inverter efficiency (peak)	93.7%
HBCO/HBCI (High Battery Cut Out/In)	33.6 VDC/33.0 VDC
LBCO/LBCI (Low Battery Cut Out/In)	18.0 VDC (adj)/25.0 VDC
Inverter stacking (series or parallel)	No
AC relay transfer time (minimum)	<16 msec
Power consumption – searching	<7 watts
Power consumption – inverting (no load)	25 watts
Output waveform	Pure Sine Wave
Charger Specifications	
Continuous charger output at 25°C	110 ADC
Input current for continuous rated output	29 AAC
Maximum current during load support	160 ADC
Charger efficiency	85%
AC input frequency range	50 to 70 Hz
AC input voltage range	60 to 140 VAC (120 VAC nominal)
Power factor	> 0.95
General Features and Capabilities	
Transfer relay capability	60 AAC maximum each input
Five-stage charging capability	Bulk, Absorb, Float, Equalize (requires remote), and Battery Saver™
Battery temperature compensation	Standard with available temp sensor connected (battery temp 0-50 °C)
Internal cooling	0 to 120 cfm variable speed drive using dual 92 mm brushless DC fan
Overcurrent protection	with two overlapping circuits
Over-temperature protection	on transformer, MOSFETS, and battery
Corrosion protection	PCB's conformal coated, powder coated chassis/top, and stainless steel fasteners
Safety listings	ETL listed to UL/cUL 1741, CSA C22.2 No. 107.1-01
Warranty	3 years parts and labor
Branch-rated output circuit breakers	No
Environmental Specifications	
Operating temperature	-20°C to +60°C (-4°F to 140°F)
Non-operating temperature	-40°C to +70°C (-40°F to 158°F)
Operating humidity	0 to 95% RH non-condensing
Physical Specifications	
Unit dimensions (length x width x height)	13.75" x 12.65" x 8.0" (34.9 cm x 32.1 cm x 20.3 cm)
Shipping dimensions (l x w x h)	19.0" x 17.0" x 13.0" (48.3 cm x 43.2 cm x 33.0 cm)
Mounting	Shelf or wall (vents not allowed to face downward unless ME-CB or MMP is installed)
Weight	Unit: 58 lb (26.3 kg) / Shipping: 60 lb (27.2 kg)
Max operating altitude	15,000 ft (4570 m)
<i>Specifications @ 25°C – Subject to change without notice.</i>	

A-2 Performance Graphs

A-2.1 Inverter Efficiency Curve

The following curve is plotted to show the MSH4024RE’s efficiency over the full power range and is displayed as a percentage. This graph represents the inverter’s efficiency while operating resistive loads. Motors and other inductive loads run less efficiently due to the impact of power factor losses.

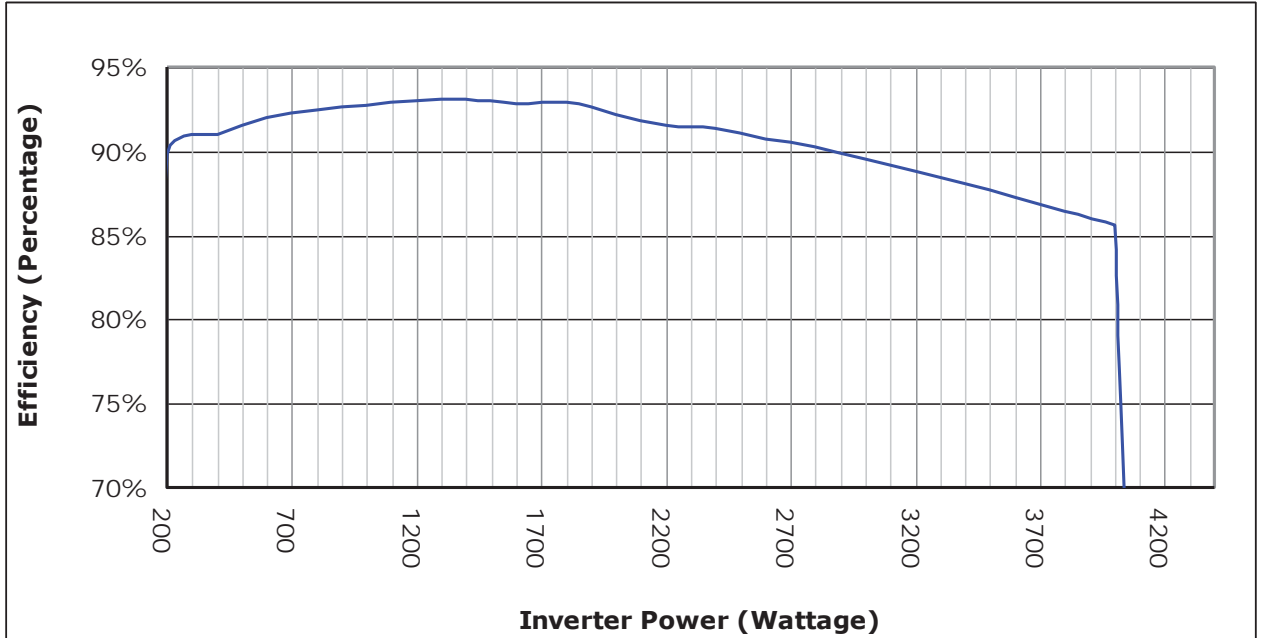

Figure A-1, MSH-RE Series Efficiency Chart

A-2.2 Inverting Temperature Curve

The following curve shows the MSH4024RE’s continuous power when the ambient temperature around the inverter is above or below 25° C. Use this chart to reduce the inverter power draw to avoid an over-temperature shutdown.

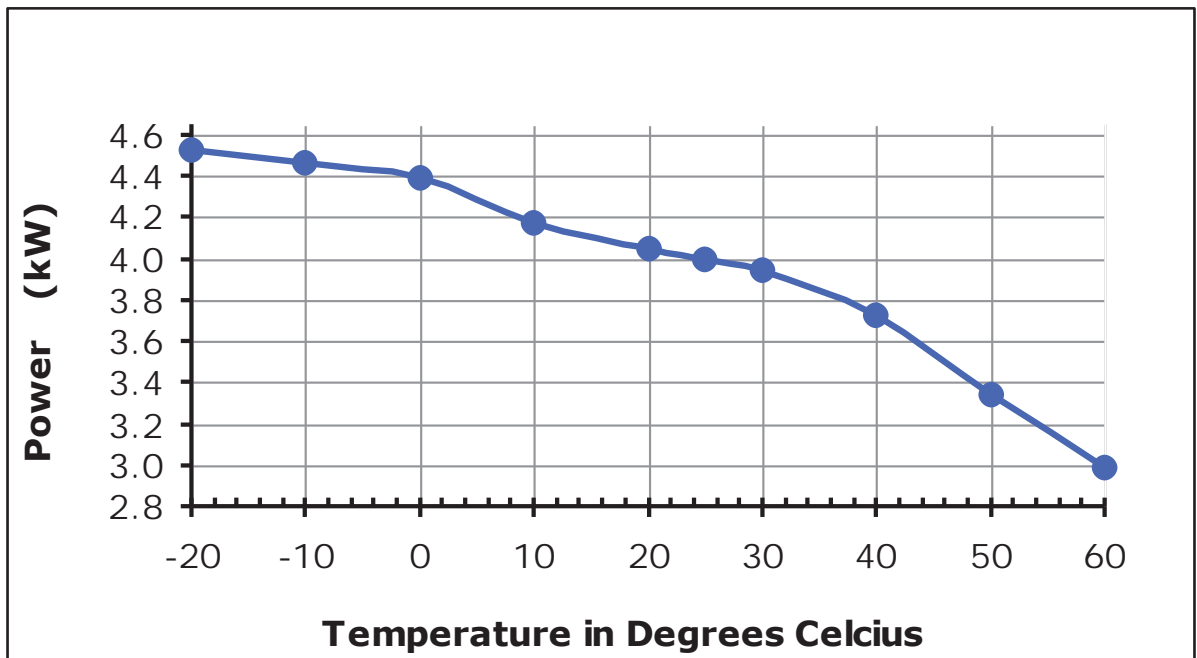

Figure A-2, MSH4024RE Inverting Temperature Curve

Appendix A – Specifications

A-2.3 Charge Current vs. Temperature Curve

As the temperature of the power devices (FETs) inside the inverter increases, the maximum allowable charger current is reduced. The following curve shows the effect of charger current with the temperature above 25° C.

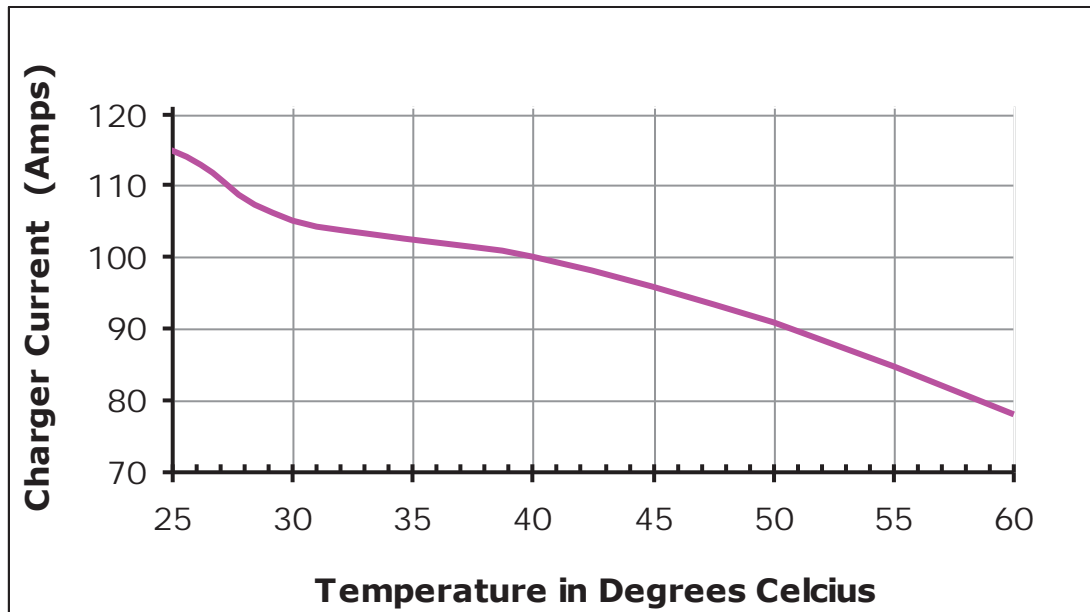

Figure A-3, MSH4024RE Charge Current vs Temperature Curve

A-3 Optional Equipment and Accessories

The following Magnum Energy components are available for use with the MSH4024RE Series inverter/charger. Some of these items are required depending upon the intended use of the inverter.

Remote Switch Adapters

The ME-RSA and ME-RSA-M pigtail adapters allow the inverter to be remotely switched on and off—with or without a remote display.

Standard Remote Control

The ME-RC remote control panel uses an LCD screen and at-a-glance LED displays for complete inverter/charger status, with soft keys and encode knob to provide simple access to menus.

Advanced Remote Control

The ME-ARC remote control panel uses an LCD screen and at-a-glance LED displays to provide advanced monitoring, troubleshooting and feature configuration.

Auto Generator Start Controller

The ME-AGS-N Automatic Generator Start controller (Network version) is designed to automatically start your generator based on low battery condition or high temperature. Adjustable settings when using the ME-ARC include starting the generator based on battery voltage, time of day, battery State of Charge, or high temperature.

Battery Monitor Kit

The ME-BMK (and ME-BMK-NS) Battery Monitor Kit is a single battery bank amp-hour meter that monitors the condition of the battery, provides information to let you know how much energy is available, and lets you plan your electrical usage to ensure the battery is not being over-discharged.

ME-CB and MPX-CB Conduit Boxes

The ME-CB and MPX-CB Conduit Boxes are provided for installations where the electrical code requires the AC and/or DC wiring to your Magnum inverter to be enclosed and protected by conduit.

Appendix B – Battery Information

B-1 Battery Location

Periodic maintenance (i.e., checking connections, cleaning, watering) on batteries is required. Locate the batteries in an accessible location to perform this maintenance.

Batteries must be mounted in a clean, dry, ventilated environment where they are protected from high and low temperatures. The battery bank should be located as close to the inverter as possible without limiting access to the inverter's disconnects. Longer battery cable runs tend to lose efficiency and reduce the overall performance of an inverter.

To ensure optimum performance, a ventilated battery enclosure is recommended. Two feet of clearance above the batteries is recommended for access to the battery terminals and removable caps (lead acid battery types).



WARNING: Be very careful when working around batteries, they can produce extremely high currents if they are short-circuited. Read the important safety instructions at the beginning of this manual and the precautions from the battery supplier before installing the inverter and batteries.



CAUTION: Do not mount the batteries beneath the inverter (or in the same compartment). Batteries emit corrosive fumes which could damage the inverter's electronics. Never locate dedicated batteries near a vehicle/home fuel tank containing gasoline or propane.

B-2 Battery Types

Batteries are available in different sizes, amp-hour ratings, voltage and chemistries. They are also available for starting applications (such as an automobile starting battery) and deep discharge applications. Only the **deep cycle** types are recommended for inverter applications; using a starting battery in an inverter (deep cycle) application will greatly shorten their useful life. Choose the batteries best suited for the inverter installation and cost. Use only the same battery type for all batteries in the bank. For best performance, all batteries should be from the same lot and date. This information is usually printed on a label located on the battery.

B-3 Battery Temperature

Battery performance of lead-acid type batteries is greatly affected by extreme temperatures. When a lead-acid type battery is cold, its effective amp-hour capacity is reduced. When determining the battery requirements needed for the inverter system, realize that the battery capacity will be reduced if they will be installed in a climate where extremely cold temperatures are expected. In this type of environment, the batteries should be located in a heated area. At the minimum, the batteries should be installed in an insulated enclosure; which will keep the batteries warmer as they are being charged.

The battery bank should also be protected from high temperatures, which will shorten battery life. In high heat situations the battery room/enclosure should be ventilated to bring in cooler air and exhaust the hotter air. The performance of the battery bank/inverter system will substantially increase by monitoring and preventing extreme temperatures around the batteries.

B-4 Battery Bank Sizing

The size of the battery bank determines how long the inverter will power the AC loads without recharging. The larger the battery bank, the longer the run time. Size your battery bank to the systems AC load requirements and length of time required to run from the batteries. In general, the battery bank should not be discharged more than 50%. Additional DC charging devices such as solar, wind, hydro, etc., can provide longer run times by recharging the batteries in the absence of AC utility or generator power.



Info: For the MSH-RE Series inverter/charger to perform optimally, a minimum battery bank of 200 AH is recommended for moderate loads (<1000W) and greater than 400 AH for heavy loads (≥1000W).

Appendix B – Battery Information

B-5 Battery Bank Sizing Worksheet

Complete the steps below to determine the battery bank size required to power your AC loads.

1. Determine the daily power needed for each load.

- List all AC loads required to run, then
- List the wattage for each load (see Table C-1 for common loads/wattage), then
- Multiply by how many hours per day (or a fraction of an hour) each load will be used, then
- Multiply by how many days per week you will use the listed loads, and finally
- Divide by seven = **Average Daily Watt-Hours Per Load**

Average Daily Watt-Hours Per Load				
AC load	Wattage	(x) Hours per day	(x) Days per week	(÷7) = Total power

2. Determine the total power needed each day for all the loads.

- Add all the *Average Daily Watt-Hours Per Load* together = **Total Daily Watt-Hours**.

3. Determine the battery amp-hour capacity needed to run all the loads before recharging.

- Divide the *Total Daily Watt-Hours* by the nominal battery voltage of the inverter (i.e., 12, 24 volts), then
- Multiply this by how many days the loads will need to run without having power to recharge the batteries (typically 3 to 5 days of storage) = **Storage Amp-Hours**

(inverter battery voltage)
 ÷ ____ =

(days of storage)
 x ____ =

Total Daily Watt-Hours

4. Determine how deeply you want to discharge your batteries.

- Divide the *Storage Amp-Hours* by 0.2 or 0.5 to get the **Total Amp-Hours**:
 - 0.2 = Discharges the batteries by 20% (80% remaining), this is considered the optimal level for long battery life; or
 - 0.5 = Discharges the batteries by 50% (50% remaining), this is considered a realistic trade-off between battery cost and battery life

Total Amp-Hours

Additional compensation

Low battery temperature: If the batteries are installed in a location that will be exposed to low temperatures, the available output will be less. In these instances, you will need to determine the lowest temperature the battery bank will experience and multiply the *Total Amp-Hours* by the multiplier below.

Temperature	80F/27C	70F/21C	60F/15C	50F/10C	40F/4C	30F/-1C	20F/-7C
Multiplier	1.00	1.04	1.11	1.19	1.30	1.40	1.59

Inverter efficiency: When the inverter is used in a back-up power application the inverter efficiency will not be a large concern; however, if the inverter is the primary AC source for the calculated load, the *Total Amp-Hours* should be multiplied by 1.2 to factor in an average 80% inverter efficiency.

B-6 Battery Wiring Configurations

The battery bank must be wired to match the inverter’s DC input voltage. In addition, the batteries can be wired to provide additional run time. The various wiring configurations are:

B-6.1 Series Wiring

Wiring batteries in series increases the battery bank’s output voltage. A series connection combines each battery in a string until the total voltage matches the inverter’s DC requirement. Even though there are multiple batteries, the capacity remains the same. In Figure B-1 below, two 6 VDC/200 AH batteries are combined into a single string resulting in a 12 VDC, 200 AH bank.

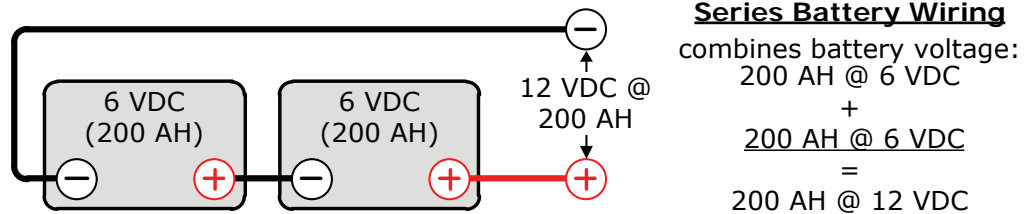

Figure B-1, Series Battery Wiring

B-6.2 Parallel Wiring

Wiring batteries in parallel increases the battery bank’s amp-hour capacity, which allows the AC loads to operate for a longer time. A parallel connection combines the number of batteries in the string to increase overall battery capacity; however, the voltage remains the same. In Figure B-2 below, two 12 VDC/100 AH batteries are combined into a single 12 VDC, 200 AH battery bank.

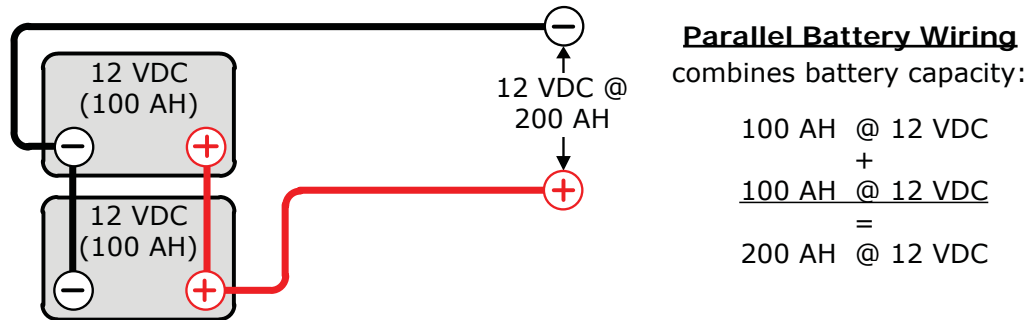

Figure B-2, Parallel Battery Wiring

B-6.3 Series-Parallel Wiring

A series/parallel configuration increases both voltage (to match the inverter’s DC requirements) and amp-hour capacity (to increase run-time for operating the loads) using smaller, lower-voltage batteries. In Figure B-3 below, four 6 VDC/200 AH batteries are combined into two strings resulting in a 12 VDC, 400 AH battery bank.

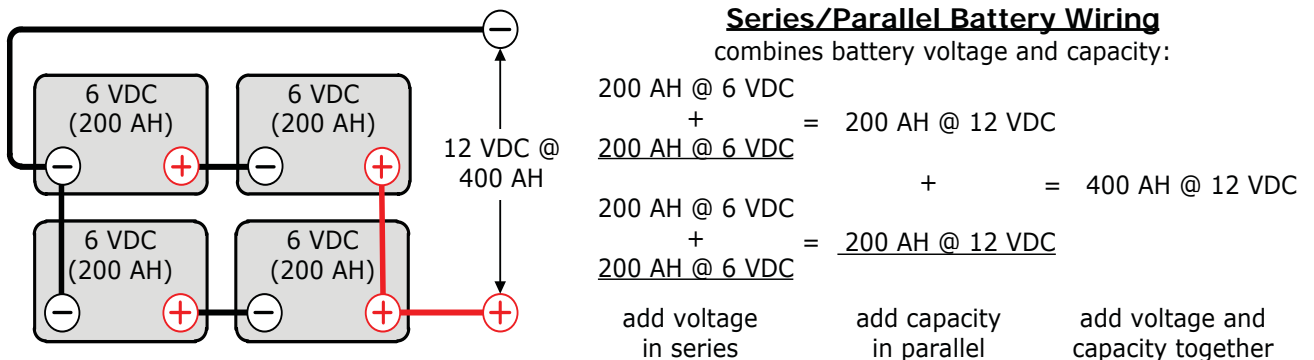

Figure B-3, Series-Parallel Battery Wiring

Appendix B – Battery Information

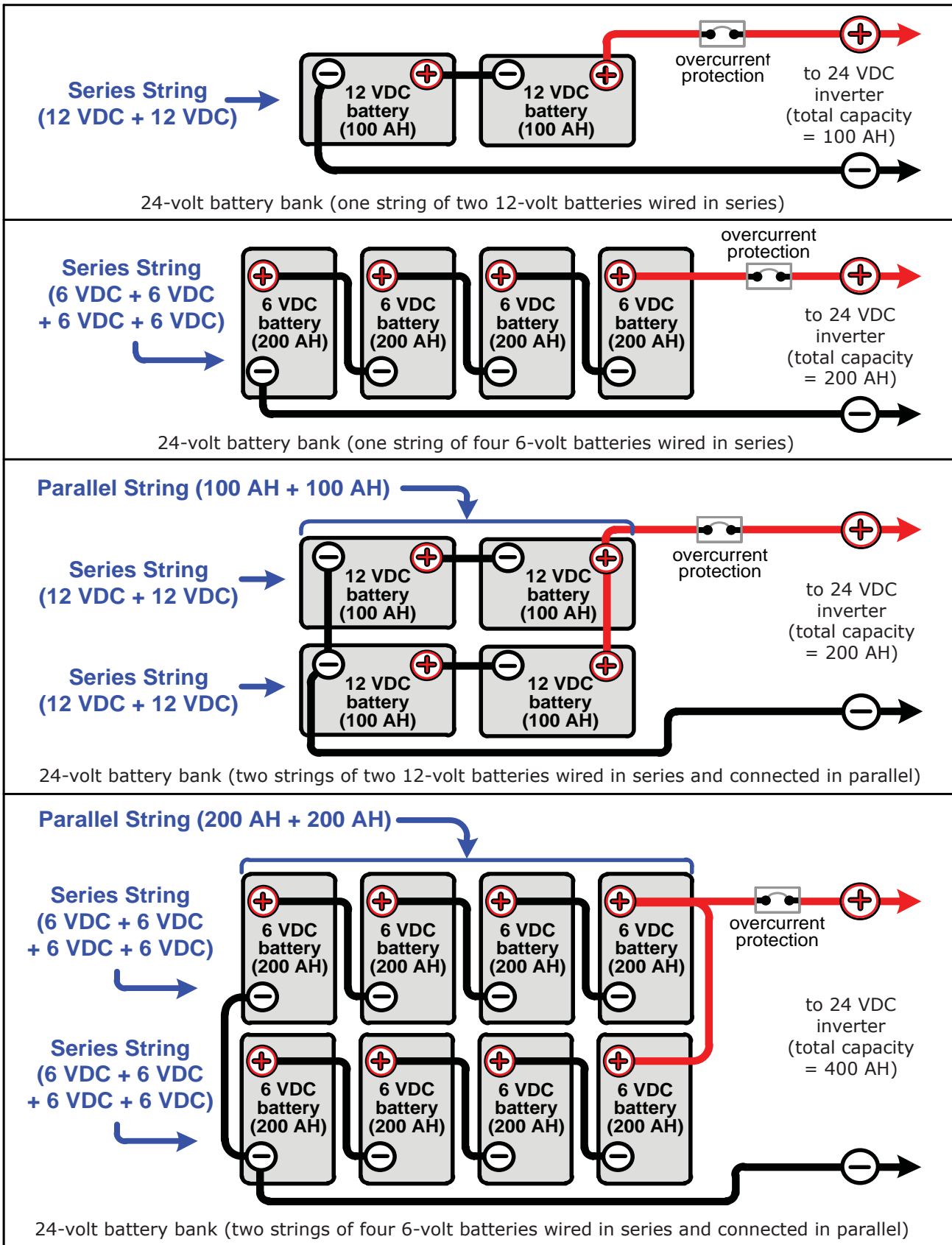

Figure B-4, Battery Bank Wiring Examples (24-volt)

Appendix C – Power Consumption and Output Waveforms

C-1 Appliance Power Consumption

The MSH-RE Series inverter/charger can power a wide range of household appliances including small motors, hair dryers, clocks, and other electrical devices. As with any appliance using batteries for power, there is a certain length of time that it can run—this is called “run time.” Actual run time depends on several variables including the size and the type of appliance, the type of batteries installed in your application, as well as the battery’s capacity and age. Other factors such as the battery’s state of charge and temperature can also affect the length of time your appliances can run. Appliances (TVs, VCRs, stereos, computers, coffee pots, incandescent lights, and toasters) can all be successfully powered by your inverter. Larger electrical appliances, however, such as stoves, water heaters, etc., can quickly drain your batteries and are not recommended for this application. All electrical appliances are rated by the amount of power they consume (see Table C-1). The rating is printed on the product’s nameplate label, usually located on its chassis near the AC power cord. Even though it is difficult to calculate exactly how long an inverter will run a particular appliance, the best advice is trial and error. Your MSH-RE Series inverter has a built-in safeguard that automatically protects your batteries from over-discharge.

Table C-1, Typical Appliance Power Consumption

Device	Load	Device	Load	Device	Load
Blender	400W	Coffee Maker	1200W	Light (Flo)	10W
Computer	300W	Color TV	150W	Microwave	1000W
Drill	500W	Hair Dryer	1000W	Light (Inc)	100W
Hot Plate	1800W	Iron	1000W	Refrigerator	500W

C-2 Inverter Output Waveforms

The inverter’s output waveform is the shape of the wave that alternating current makes as its voltage rises and falls with time. Today’s inverters come in three basic output waveforms: square wave, modified sine wave and pure sine wave.

- **Square Wave** – The simplest AC waveform. Some types of equipment behave strangely when powered from a square wave inverter.
- **Modified Sine Wave** – Also referred to as a “quasi sine wave”. This output looks like a one-step staircase and the waveform changes its width to continually provide the correct RMS output voltage regardless of the battery voltage. Most loads that run from a sine wave will also run from a modified sine wave. However, things such as clocks and furnace controllers may have trouble.
- **Sine Wave** – An AC waveform that looks like rolling waves on water. It rises and falls smoothly with time. The grid puts out a sine waveform. Any plug-in AC equipment will operate from a sine wave inverter.

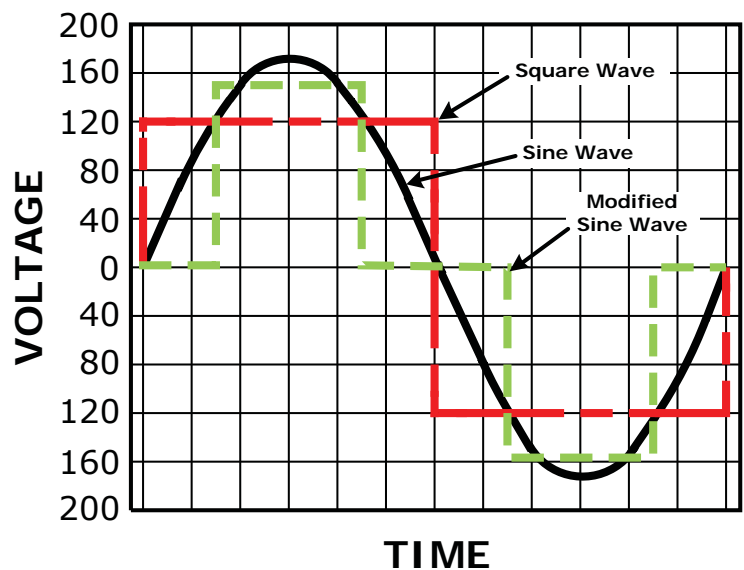

Figure C-1, AC Waveforms

Appendix D – Inverter/Charger Terminology

The following is a glossary of terms with which you may not be familiar. They appear in the various descriptions of inverter and battery charger operation.

Absorption Stage – In this second stage of three stage charging, the batteries are held at a constant voltage (the absorb voltage setting) and the battery is charged to its maximum capacity.

AC (Alternating Current) – Electrical current that varies with time (i.e., utility power). The rate at which the voltage changes polarity is the frequency in Hertz (Hz).

Ampacity – The ampacity of a wire is its current carrying capacity with reference to the cross-sectional area of the conductors, the temperature rating of the insulation and the ambient temperature.

Automatic Transfer Relay (inside the inverter) – An automatic switch that switches between Inverter and Standby mode depending on availability of AC input power. If AC is present, the unit will be a battery charger and pass power through the inverter. When the AC goes away, the unit becomes an inverter.

Bulk Charge Stage – The first stage in three stage charging. In this stage, a constant current is fed to the batteries and as they accept the current the battery voltage will rise.

CEC (Canadian Electrical Code) – The guidelines and acceptable practices for electrical installations in Canada.

Current (Amps) – The amount of electricity flowing through a conductor.

DC (Direct Current) – Electrical current that does not vary with time (i.e., battery voltage).

Deep Cycle – A deep cycle occurs when a battery is discharged to less than 20% of its capacity (80% depth-of-discharge).

Deep Cycle Battery – A battery designed to be routinely discharged to 20% of its maximum capacity without damage. This type of battery is recommended for use with an inverter system.

Derating – As an inverter (or charger) is used above its normal temperature, its capacity to power loads (or charge) continuously is decreased.

Digital Volt Meter (DVM):

True RMS – A voltmeter that incorporates a RMS converter to read true RMS for any waveform shape.

Averaging Type – A voltmeter that requires a sine wave waveform shape to provide an accurate reading.

Efficiency – Usually given as a percentage, efficiency is the ratio of the output to the input. The efficiency changes with power output levels of any inverter.

Electrolyte – Typically a mixture of water and sulfuric acid that is used in lead-acid batteries; it is commonly referred to as battery acid.

Equalization – Controlled “overcharging” of the battery causing it to bubble and mix. This helps reduce stratification.

Float Stage – During the third stage of three stage charging, the voltage and current are reduced to a level that will trickle charge or maintenance charge the battery. This assures the battery remains fully charged even while sitting.

Fuse or Disconnect – When current exceeds a preset limit the fuse or disconnect will fail before the wiring or equipment it is protecting. Disconnects are also called circuit breakers. These are usually reset and can act as a switch to turn off power to equipment for servicing.

Grid (The grid) – Also called the utility grid, this refers to the public power distribution system.

Impedance – Slows the electrical flow of alternating current (AC).

Islanding - The condition present when the utility power grid fails and the inverter attempts to power the grid. An inverter which is “islanding protected” senses the loss of AC power from the grid and does not back feed into the grid system.

Appendix D – Inverter/Charger Terminology

LED (Light Emitting Diode) – A light made up of semi-conducting material.

Line Tie – Term used when the inverter is connected to public power or the “grid” system.

Load(s) – An electrical item that draws power (i.e., lights, radio, refrigerator, etc.,) to work.

Locked Rotor Amps – The current drawn by an electric motor with the shaft or rotor stopped and locked in position. This can be used to determine if an inverter has enough surge current to start a motor. If the inverter is capable of producing more amperage than the locked rotor amps rating of a motor, it will most likely start the motor easily.

NEC (National Electric Code) – The guidelines and acceptable practices for electrical installations in the USA.

Off Grid – Not connected to public power in any way.

Pass Through Current – The amount of current the inverter can safely pass directly from the AC input to the AC output.

Photovoltaic (PV) – Solar powered.

Resistance (Ohms) – Slows the electrical flow of direct current (DC).

RMS (Root Mean Square) – A measure of AC voltage that provides the equivalent heating value across a resistor as would a DC source of the same voltage.

Sellback, or Selling Back To The Grid or Utility-Interactive – Some inverters have the capability to take energy stored in batteries, or from solar panels, and put it back into the utility grid. The local public utility company can compensate you for using this energy.

Shorepower – The process of providing shoreside electrical power to a boat while its main and auxiliary engines are turned off. The source for shorepower may be grid power from an electric utility company, or from an external remote generator.

Stacking:

Series – Two inverters operating together to produce twice the power and voltage of a single inverter. Required when operating 240 VAC loads and separate 120 VAC loads from either inverter.

Parallel – Two inverters operating together to provide twice the continuous capacity on a single output circuit. Required when a single load is too large for one inverter.

Stratification – Over time, a battery’s electrolyte (liquid) tends to separate. The electrolyte at the top of the battery becomes watery while at the bottom it becomes more acidic. This effect is corrosive to the plates.

Sulfating – As a battery discharges, its plates become covered with lead sulfate. During recharging, the lead sulfate leaves the plates and recombines with the electrolyte. If the lead sulfate remains on the plates for an extended period of time (over two months), it hardens, and recharging will not remove it. This reduces the effective plate area and the battery’s capacity.

Temperature Compensation – Peak available battery voltage is temperature dependent. As ambient temperatures fall, the proper voltage for each charge stage needs to be increased. A Battery Temperature Sensor (BTS) automatically re-scales charge-voltage settings to compensate for ambient temperatures.

Voltage – The pressure that causes electrical flow in a circuit.

Watts – Measure of power output or utilization. Watts = Volts x Amps.

Appendix E – Warranty and Service Information

E-1 Limited Warranty

Magnum Energy, Inc., warrants the MSH-RE Series to be free from defects in material and workmanship that result in product failure during normal usage, according to the following terms and conditions:

1. The limited warranty for the product extends for 24 months beginning from the product's original date of purchase.

Note: *The normal 2-year warranty on this MSH-RE inverter is extended to 5 years if it was ordered with and installed on a Magnum MMP panel system. A proof-of-purchase is required at the time of repair/service showing that the MSH-RE inverter and the MMP panel system were purchased at the same time.*

2. The limited warranty extends to the original purchaser of the product and is not assignable or transferable to any subsequent purchaser.
3. During the limited warranty period, Magnum Energy will repair or replace at our option any defective parts, or any parts that will not properly operate for their intended use, with factory new or remanufactured replacement items if such repair or replacement is needed because of product malfunction or failure during normal usage. The limited warranty does not cover defects in appearance, whether cosmetic or decorative, or any structural or non-operative parts. Magnum Energy's limit of liability under this warranty shall be the actual cash value of the product at the time the original purchaser returns the product for repair, determined by the price paid by the original purchaser. Magnum Energy shall not be liable for any other losses or damages.
4. Upon request from Magnum Energy, the original purchaser must prove the product's original date of purchase by a dated bill of sale, itemized receipt.
5. The original purchaser shall return the product prepaid to Magnum Energy in Everett, WA. After the completion of service under this limited warranty, Magnum Energy will return the product prepaid to the original purchaser via a Magnum-selected non-expedited surface freight within the contiguous United States and Canada; this excludes Alaska and Hawaii.
6. If Magnum repairs or replaces a product, its warranty continues for the remaining portion of the original warranty period or 90 days from the date of the return shipment to the original purchaser, whichever is greater. All replaced products and parts removed from repaired products become the property of Magnum.
7. This limited warranty is voided if:
 - the product has been modified without authorization
 - the serial number has been altered or removed
 - the product has been damaged from abuse, neglect, accident, high voltage or corrosion
 - the product was not installed and operated according to the owner's manual

E-2 How to Receive Repair Service

If your product requires warranty service or repair, contact either:

- An Authorized Service Center, which are listed on the Magnum Energy website at <http://www.magnumenergy.com/Service/ServiceCenters-US.htm>; or
- Magnum Energy, Inc. at: Telephone: 425-353-8833
Fax: 425-353-8390
Email: warranty@magnumenergy.com

If returning the product directly to Magnum Energy for repair, you must:

1. Return the unit in the original, or equivalent, shipping container.
2. Receive a Return Materials Authorization (RMA) number from the factory prior to the return of the product to Magnum Energy for repair.
3. Place the assigned RMA numbers clearly on the shipping container or on the packing slip.

When sending your product for service, please ensure it is properly packaged. **Damage due to inadequate packaging is not covered under warranty.** We recommend sending the product by traceable or insured service.

**BEFORE RETURNING ANY UNIT,
A RETURN MATERIAL AUTHORIZATION (RMA) NUMBER IS REQUIRED**



Magnum Energy, Inc.
2211 West Casino Rd.
Everett, WA 98204
Phone: 425-353-8833
Fax: 425-353-8390
Web: www.magnumenergy.com