



MS-PAE Series Pure Sine Wave Inverter / Charger



Owner's Manual



Disclaimer of Liability

Since the use of this manual and the conditions or methods of installation, operation, use and maintenance of the MS-PAE Series Inverter/Charger is beyond the control of Magnum Energy Inc., this company does not assume responsibility and expressly disclaims liability for loss, damage or expense, whether direct, indirect, consequential or incidental, arising out of or anyway connected with such installation, operation, use, or maintenance.

Due to continuous improvements and product updates, the images shown in this manual may not exactly match the unit purchased.

Restrictions on Use

The MS-PAE Series Inverter/Charger shall not be used in connection with life support systems, life saving or other medical equipment or devices. Using the MS-PAE Series Inverter/Charger with this particular equipment is at your own risk.

Contact Information

Magnum Energy, Inc.
2211 West Casino Rd.
Everett, WA 98204
Phone: 425-353-8833
Fax: 425-353-8390
Web: www.magnumenergy.com

Record the unit's model and serial number in case you need to provide this information in the future. It is much easier to record this information now, instead of trying to gather it after the unit has been installed.	
Model:	Serial Number:
<input type="checkbox"/> MS3748PAEJ	AH
<input type="checkbox"/> MS4024PAE	AA
<input type="checkbox"/> MS4448PAE	AB

IMPORTANT SAFETY INSTRUCTIONS

- This manual contains important safety instructions that must be followed during the installation and operation of this product.
- All electrical work must be performed in accordance with local, state and federal electrical codes.
- Read all instructions and safety information contained in this manual before installing or using this product.
- This product is designed for indoor / compartment installation. It must not be exposed to rain, snow, moisture or liquids of any type.
- Use insulated tools to reduce the chance of electrical shock or accidental short circuits.
- Remove all jewelry such as rings, watches, bracelets, etc., when installing or performing maintenance on the inverter.
- Always disconnect the batteries or energy source prior to installing or performing maintenance on the inverter.
- Live power may be present at more than one point since an inverter utilizes both batteries and AC.
- Always verify proper wiring prior to starting the inverter.
- There are no user serviceable parts contained in this product.
- This unit is provided with integral protection against overloads.
- The input and output AC and DC circuits are isolated from the inverter chassis. The inverter system grounding is the responsibility of the installer in accordance with the NEC.
- Both AC and DC overcurrent protection must be provided as part of the installation.
- Class 1 wiring methods are to be used for field wiring connections to terminals of a Class 2 circuit.
- Use only copper wires with a minimum temperature rating of 90°C.

Safety Symbols

To reduce the risk of electrical shock, fire, or other safety hazard, the following safety symbols have been placed throughout this manual to indicate dangerous and important safety instructions.



WARNING: This symbol indicates that failure to take a specified action could result in physical harm to the user.



CAUTION: This symbol indicates that failure to take a specified action could result in damage to the equipment.



Info: This symbol indicates information that emphasizes or supplements important points of the main text.



Remedy: This symbol provides possible solutions for related issues.

SAVE THESE INSTRUCTIONS

IMPORTANT BATTERY SAFETY INSTRUCTIONS

- Wear eye protection such as safety glasses when working with batteries.
- Remove all jewelry such as rings, watches, bracelets, etc., when installing or performing maintenance on the inverter.
- Never work alone. Always have someone near you when working around batteries.
- Use proper lifting techniques when working with batteries.
- Never use old or untested batteries. Check each battery's label for age, type and date code to ensure all batteries are identical.
- Batteries are sensitive to changes in temperature. Always install batteries in a stable environment.
- Install batteries in a well ventilated area. Batteries can produce explosive gasses. For compartment or enclosure installations, always vent batteries to the outside.
- Provide at least one inch of air space between batteries to provide optimum cooling.
- Never smoke when in the vicinity of batteries.
- To prevent a spark at the battery and reduce the chance of explosion, always connect the cables to the batteries first. Then connect the cables to the inverter.
- Use insulated tools at all times.
- Always verify proper polarity and voltage before connecting the batteries to the inverter.
- To reduce the chance of fire or explosion, do not short-circuit the batteries.
- In the event of accidental exposure to battery acid, wash thoroughly with soap and water. In the event of exposure to the eyes, flood them for at least 15 minutes with running water and seek immediate medical attention.
- Recycle old batteries.

SAVE THESE INSTRUCTIONS

Table of Contents

Introduction

1.0 Introduction.....	1
1.1 Features and Benefits.....	3
1.2 How the MS-PAE Series Inverter/Charger Works	5

Installation

2.0 Installation	6
2.1 Pre-Installation	6
2.2 Grounding Inverters.....	12
2.3 DC Wiring.....	16
2.4 AC Wiring	22
2.5 Inverter Warning Label.....	26
2.6 Functional Test.....	27

Operation

3.0 Operation	28
3.1 Inverter Mode	28
3.2 Standby Mode.....	29
3.3 Battery Temperature Sensor Operation	31
3.4 Protection Circuitry Operation.....	32
3.5 Start-Up.....	33
3.6 Factory Default Values.....	34

Troubleshooting

4.0 Troubleshooting.....	35
4.1 Performing an Inverter Reset	36

Parallel Operation

5.0 Parallel Operation	37
5.1 Overview.....	37
5.2 Conditions for Parallel Operation	37
5.3 Parallel System Connections and Components	39

Appendix

Specifications

A.1 Specifications.....	40
A.2 Efficiency Graphs.....	41

Optional Equipment/Accessories

B.1 Optional Equipment/Accessories	42
--	----

Battery Information

C.1 General Battery Information	43
C.2 Battery Bank Sizing Worksheet.....	44
C.3 Battery Wiring	45

Warranty and Service

D.1 Limited Warranty.....	48
D.2 How to Receive Repair Service	48

Table of Figures

Figure 1-1, Power Switch, Status LED and Accessory Connection Ports.....	2
Figure 1-2, Electrical Connection Points	2
Figure 1-3, Left Side Features	4
Figure 2-1, Simplified Installation Diagram - Single Inverter.....	7
Figure 2-2, Approved Mounting Positions	9
Figure 2-3, MS-PAE Series Dimensions	10
Figure 2-4, Grounding System for MS-PAE Series.....	12
Figure 2-5, Multiple Connections to DC Ground Rod (Method 1)	13
Figure 2-6, Multiple Connections to DC Ground Rod (Method 2)	14
Figure 2-7, Single Connection to DC Ground Rod (Method 3).....	14
Figure 2-8, DC and Battery Temperature Sensor Wiring	17
Figure 2-9, Battery Hardware Installation	19
Figure 2-10, Inverter DC Hardware Installation.....	19
Figure 2-11, Battery Temperature Sensor	20
Figure 2-12, AC Terminal Block	23
Figure 2-13, AC Wiring.....	24
Figure 2-14, Warning Label.....	26
Figure 2-15, AC Voltage Checks.....	27
Figure 3-1, Power Flow - Inverter Mode	28
Figure 3-2, Power Flow - Standby Mode.....	29
Figure 3-3, Automatic 4-Stage Charging Graph.....	30
Figure 3-4, BTS Temperature to Charge Voltage Change	31
Figure 3-5, Power Switch and Status Indicator.....	33
Figure 4-1, Performing an Inverter Reset	36
Figure 5-1, Simplified Installation Diagram - Multiple Inverters (stacked in parallel).....	38
Figure 5-2, Simplified Magnum Panel (AC Panel).....	39
Figure 5-3, Simplified Magnum Panel (DC Panel).....	39
Figure A-1, MS4024PAE Efficiency Graph	41
Figure A-2, MS4448PAE Efficiency Graph	41
Figure C-1, Series Battery Wiring.....	45
Figure C-2, Parallel Battery Wiring	45
Figure C-3, Series-Parallel Battery Wiring.....	45
Figure C-4, Battery Bank Wiring Examples (24-volt).....	46
Figure C-5, Battery Bank Wiring Examples (48-volt).....	47

Table of Tables

Table 2-1, AC Grounding Electrode Conductor Sizing	13
Table 2-2, Equipment Grounding Conductor Sizing	15
Table 2-3, Recommended DC Wire/Overcurrent Device	18
Table 2-4, DC Wire Size For Increased Distance	19
Table 3-1, Inverter Battery Turn On/Off Levels.....	32
Table 3-2, Inverter/Charger Default Values	34
Table 4-1, Troubleshooting Guide.....	35
Table A-1, MS-PAE Specifications	40
Table C-1, Typical Appliance Power Consumption.....	43

1.0 Introduction

Congratulations on your purchase of the MS-PAE Series inverter/charger from Magnum Energy. The MS-PAE Series is a "pure" sine wave inverter designed to provide 120 and 240VAC in a single unit to power loads when inverting and also while charging. It has two 120VAC lines (L1 and L2), a neutral and a ground. The two 120VAC output lines are 180° out-of-phase with each other, so that the combination of the L1 and L2 lines total 240VAC and the voltage between either L1 or L2 and neutral is 120VAC. The MS-PAE Series charger can accept 120VAC input (to L1 or L2) or 120/240 VAC split-phase input power (to L1 and L2), the incoming AC power is shared with the charger and the output continues to be 120/240VAC with either a 120VAC or a 120/240VAC input.

When the power requirements of the system are beyond the capacity of a single MS-PAE Series inverter or the system is expanded as more loads are added, up to four MS-PAE Series inverters can be connected together in a parallel configuration. Connecting inverters in parallel increases the overall inverter power and surge capacity to power a large single load or several smaller loads.

Simply connect the inverter's output to your distribution circuits or electrical panel; connect your utility or generator power (AC) to the inverter's easy-to-reach terminal block; connect the batteries, and then switch on the power. Using optional remote controls (ME-RTR, ME-ARC or ME-RC), you can easily operate and monitor your inverter from a remote location.

The MS-PAE Series Inverter/Charger includes the following:

- High wattage output in a small footprint - less weight and area needed for install.
- Ability to parallel up to four identical MS-PAE inverters to increase output power capability (requires ME-RTR).
- Pure sine wave output (<5% THD).
- 120/240 VAC Split phase output in a single inverter.
- PFC (Power Factor Corrected) multi-stage battery charger.
- RS485 standard communication protocol.
- Remote and Network ports (easy connection for optional accessories).
- ON/OFF Inverter-mounted switch with LED indicator.
- Large AC access and terminal block [wire size: #18 to #2 AWG (0.82 to 33.6 mm²) CU].
- DC terminal covers with 360 degree connection.
- Battery Temperature Sensor - for optimum charging during extreme temperature changes.
- Field Serviceable for qualified personnel - tested repair kits available.
- Smooth, aesthetically pleasing design.
- MS4024PAE and MS4448PAE are ETL listed to UL/cUL STD 1741 and CSA STD 22.2 107.01-01 for safety.

The following accessories are also available for MS-PAE Series products:

- **ME-RTR** (Router Control Panel) - uses a four-line LCD display to provide operating information and setup/troubleshooting capabilities for multiple Magnum inverters. Provides four ports that allow MS-PAE models to be connected in a parallel configuration to increase output power capacity.
- **ME-ARC** (Advanced Remote Control Panel) - uses a two-line LCD display to allow advance inverter setup, control and troubleshooting.
- **ME-RC** (Standard Remote Control Panel) - uses two-line LCD display to allow standard inverter setup, control and troubleshooting.
- **ME-AGS-N** (Automatic Generator Start Module/Network version) - automatically starts/stops your generator.
- **ME-BMK** (Battery Monitor Kit) - provides precise DC voltage/current measurements and provides information on your battery's State of Charge (SOC) condition.

Introduction

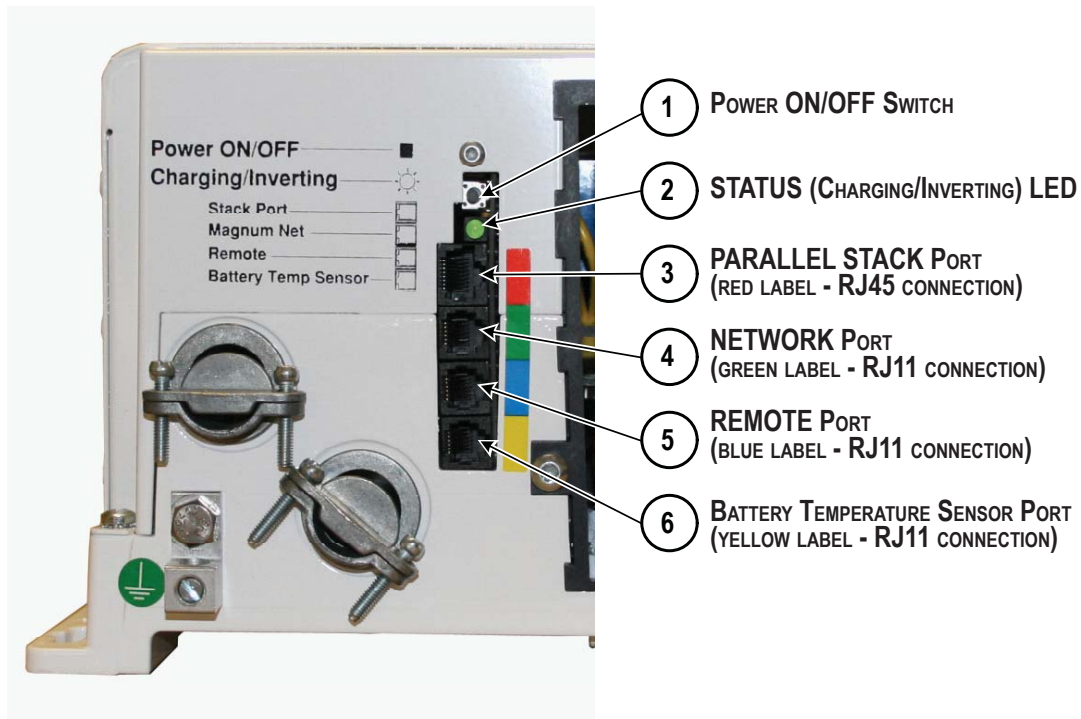

Figure 1-1, Power Switch, Status LED and Accessory Connection Ports

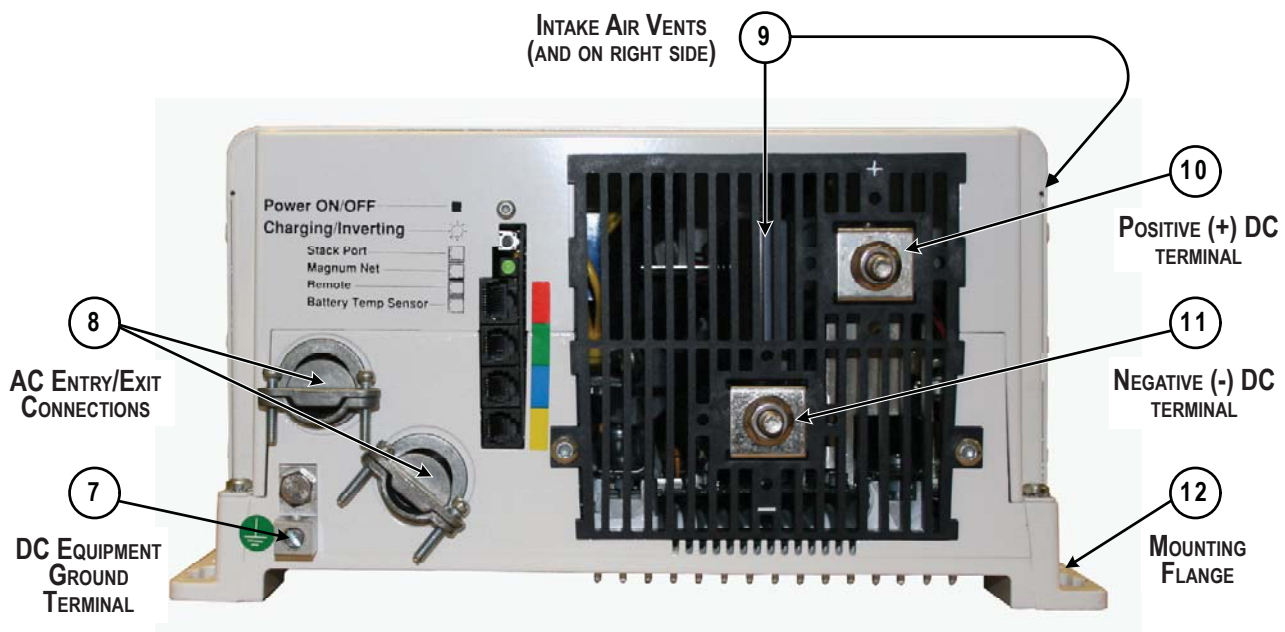

Figure 1-2, Electrical Connection Points

1.1 Features and Benefits

The MS-PAE Series inverter/charger is designed to allow easy access to wiring, circuit breakers, controls and for viewing the LED (Light Emitting Diode) status indicator. Its die cast base-plate with one piece aluminum cover ensures maximum durability with minimum weight, as well as cooler more efficient operation.

The front of the MS-PAE Series is equipped with the following features (refer to figures 1-1 and 1-2):

- 1 **Power Switch** - a momentary push-button switch that alternately turns the inverter On or Off.
- 2 **Status LED Indicator** - this green LED illuminates to provide information on the inverter or charger operation.
- 3 **Parallel Stack Connection Port (red label)** - a RJ45 port that connects to the ME-RTR Router, which is used to configure and synchronize multiple MS-PAE units to operate in parallel for increase power capacity.



CAUTION: Connect this Parallel Stack Port connection only to the ME-RTR.

Although the cabling and connectors used in this network system are the same as Ethernet connectors, this network is not an Ethernet system. Attempting to connect these two different systems may cause damage and is not covered under warranty.



Info: The MS-PAE Series Inverters cannot not be connected in parallel without installing the optional ME-RTR.

- 4 **Magnum Net Connection Port (green label)** - a RJ11 port that accepts optional Network capable accessories (i.e. Auto Gen Start or Battery Monitor).
- 5 **Remote Connection Port (blue label)** - a RJ11 port that allows optional remote control displays (i.e. ME-RC, ME-ARC, ME-RTR) to be connected.
- 6 **BTS Connection Port (yellow label)** - RJ11 port that accepts the remote Battery Temperature Sensor (BTS) accessory.
- 7 **DC Equipment Ground Terminal** - this connection is used to tie the exposed chassis of the inverter to the DC grounding system. This terminal accepts CU/AL conductors from #14 to #2 AWG (2.1 to 33.6 mm²).
- 8 **AC Entry/Exit Connections** - two 3/4" knockouts provided with cable-clamp strain reliefs to allow and hold the AC input and output field wiring.
- 9 **Intake Air Vents** - ventilation openings to pull in air to help keep the inverter cool for peak performance.
- 10 **Positive DC Terminal** - provides 360 degree connection point for the positive (+) cable from the battery bank; provided with a 5/16-18 stainless Kep or Flange nut on a 5/16-18 bolt (5/8" usable length) to hold the battery cable to the DC terminal which uses.
- 11 **Negative DC Terminal** - provides 360 degree connection point for the negative (-) cable from the battery bank; provided with a 5/16-18 stainless Kep or Flange nut on a 5/16-18 bolt (5/8" usable length) to hold the battery cable to the DC terminal.
- 12 **Mounting Flange** - used to secure the inverter to a shelf or wall.

Introduction

The left side of the MS-PAE Series is equipped with the following features (refer to figure 1-3):

- 13 **Exhaust Air Vent** - ventilation openings that allows heated air to be removed by the internal cooling fan.
- 14 **Model/Serial Number Label** - includes model/serial number information, date of manufacture and inverter and charger specifications. See the **MS-PAE Specifications** in Appendix A for more information and the different models available.
- 15 **AC Access Cover** - provides access to the internal AC wiring terminal block. This terminal block is used to hardwire all inverter AC input and output wiring connections. Remove the two screws to access the AC wiring terminal block.
- 16 **Input circuit breakers** - these circuit breakers protect the unit's internal wiring and pass-thru relay on each input (L1 and L2) while in the standby mode. These input circuit breakers are not branch-circuit rated. These circuit breakers pop out when they open, press in to reset power capacity.



CAUTION: Circuit breakers that branch-circuit rated must be installed in the inverter's input and output wiring.



CAUTION: The inverter's internal AC transfer relay is rated for 30 amps per leg, the pass-thru current must be no greater than 30 amps per leg or damage to the relays may occur.

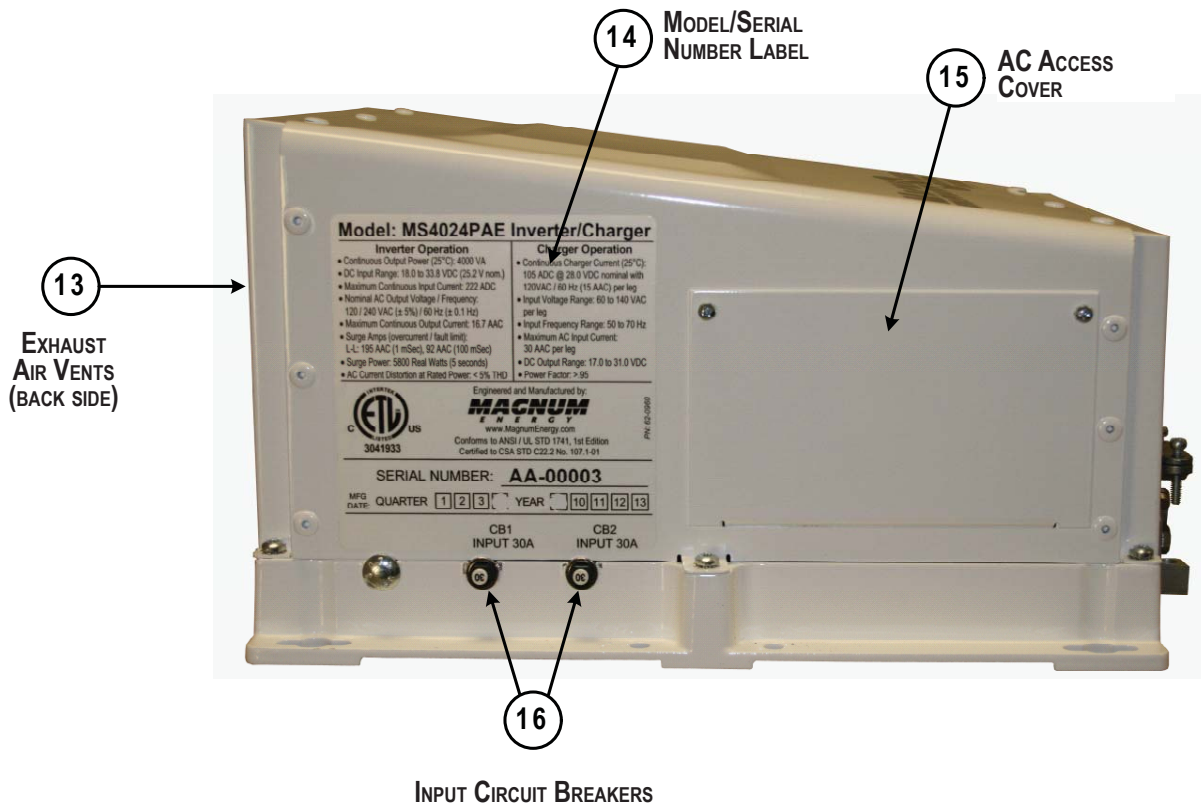

Figure 1-3, Left Side Features

1.2 How the MS-PAE Series Inverter/Charger Works

The MS-PAE Series is an electronic device that takes DC (Direct Current) voltage from your batteries and turns it into both 120V and 240V AC (Alternating Current) voltage, which is needed to power your household electrical appliances (i.e. AC loads). The MS-PAE Series also includes a battery charger circuit that takes AC power (when connected to utility/generator power) and transforms it into DC power to recharge your batteries.

1.2.1 Inverter Applications

An inverter can be used for backup power in a home or office that normally uses utility power. When the utility power is available, the inverter keeps the batteries charged. When the utility power fails, the inverter comes on automatically to supply AC power to your home or office during the power failure. For a home or business, reliable back-up power is used to prevent lost computer data or to maintain lights and keep food fresh in the refrigerator/freezer.

In some areas, where utility power is not available, this inverter can be used in an stand-alone renewable power system. The inverter allows AC electrical appliances to be run from the storage battery bank. When the battery bank becomes discharged, either renewable DC sources (solar, wind or hydro power) can be used to recharge the batteries or a generator can be connected to the inverter to power the system while the batteries recharge.

1.2.2 Advantages of a Pure Sine Wave Inverter

Today's inverters come in two basic output waveforms: modified sine (which is actually a modified square wave) and pure sine wave. Modified sine wave inverters approximate a pure sine waveform and will run most appliances and electronics without any problems. These inverters are less expensive and, therefore, offer a viable alternative to more expensive pure sine inverters.

The MS-PAE Series provides a pure sine wave output, this waveform is equal to or, in many cases, better than the grid power used in your home. Virtually any electronic device will operate from a pure sine wave inverter. Motors run cooler, microwaves usually cook faster and clocks keep better time just to name a few examples. Without compromising quality or performance, the MS-PAE Series provides you with all of the advantages of a pure sine wave inverter at a much lower cost than many in the market.

1.2.3 Appliances and Run Time

The MS-PAE Series inverter/charger can power a wide range of household appliances including small motors, hair dryers, clocks and other electrical devices. As with any appliance using batteries for power, there is a certain length of time that it can run - this is called "run time." Actual run time depends on several variables including the size and the type of appliance, the type of batteries installed in your application, as well as the battery's capacity and age. Other factors such as the battery's state of charge and temperature can also affect the length of time your appliances can run. See the Battery Bank Sizing section in Appendix C, to determine the battery bank size needed for you loads.

Appliances such as TVs, VCRs, stereos, computers, coffee pots, incandescent lights and toasters can all be successfully powered by your inverter. Larger electrical appliances, however, such as stoves, water heaters, etc., can quickly drain your batteries and are not recommended to be powered by the inverter.

All electrical appliances are rated by the amount of power they consume. The rating is printed on the product's nameplate label, usually located on its chassis near the AC power cord. Even though it is difficult to calculate exactly how long an inverter will run a particular appliance, the best advice is trial and error. Your MS-PAE Series inverter has a built-in LBCO (Low Battery Cut Out) safeguard that automatically protects your batteries from over discharge.



Info: For the MS-PAE Series inverter/charger to perform optimally, a minimum battery bank of 200 AH is recommended for moderate loads (<1000W) and greater than 400 AH for heavy loads (≥1000W).

Installation

2.0 Installation

Before installing the inverter, read the entire installation section to determine how you are going to install your MS-PAE inverter/Charger. The more thorough you plan in the beginning, the better your inverter needs will be met.



Info: If you are installing multiple MS-PAE inverters in a parallel configuration, follow all information in this section and refer to section 5.0 for specific parallel instructions.



Info: Installations should be performed by qualified personnel, such as a licensed or certified electrician. It is the installer's responsibility to determine which safety codes apply and to ensure that all applicable installation requirements are followed.



CAUTION: Review the "Important Product Safety Information" on page ii and the "Important Battery Safety Instructions" on page iii before any installation.

The simplified system diagrams shown in this manual are provided to assist you in planning and designing your installation. They are not intended to over-ride or restrict any national or local electrical codes. These diagrams should not be the determining factor as to whether the installation is compliant, that is the responsibility of the electrician and the on-site inspector.



CAUTION: The inverter is heavy. Use proper lifting techniques during installation to prevent personal injury.

2.1 Pre-Installation

2.1.1 Unpacking and Inspection

Carefully remove the MS-PAE Series inverter from its shipping container and inspect all contents. Verify the following items are included:

- The MS-PAE Inverter/Charger
- Red and black DC terminal covers with Phillips screws
- AC access cover with two Phillips screws
- Two 5/16" Kep or Flange nuts (installed on the DC terminals).
- Battery Temperature Sensor with 15 foot cable
- Warning Label
- MS-PAE Series Owner's Manual.

If items appear to be missing or damaged, contact your authorized Magnum Energy dealer or Magnum Energy.

If at all possible, keep your shipping box. It will help protect your inverter from damage if it ever needs to be returned for service.

Save your proof-of-purchase as a record of your ownership; it will also be needed if the unit should require in-warranty service.

Record the unit's model and serial number in the front of this manual in case you need to provide this information in the future. It is much easier to record this information now, instead of trying to gather it after the unit has been installed.

2.1.2 Required Components and Materials

Hardware / Materials Required:

- Conduit, strain-reliefs and appropriate fittings
- 1/4" mounting bolts and lock washers (x4 minimum)
- Wire ties
- Electrical tape

Tools Required:

- Misc. screw drivers
- Drill and drill bits
- Multimeter
- 1/2" wrench
- Pliers
- Level
- Wire strippers
- Pencil or Marker

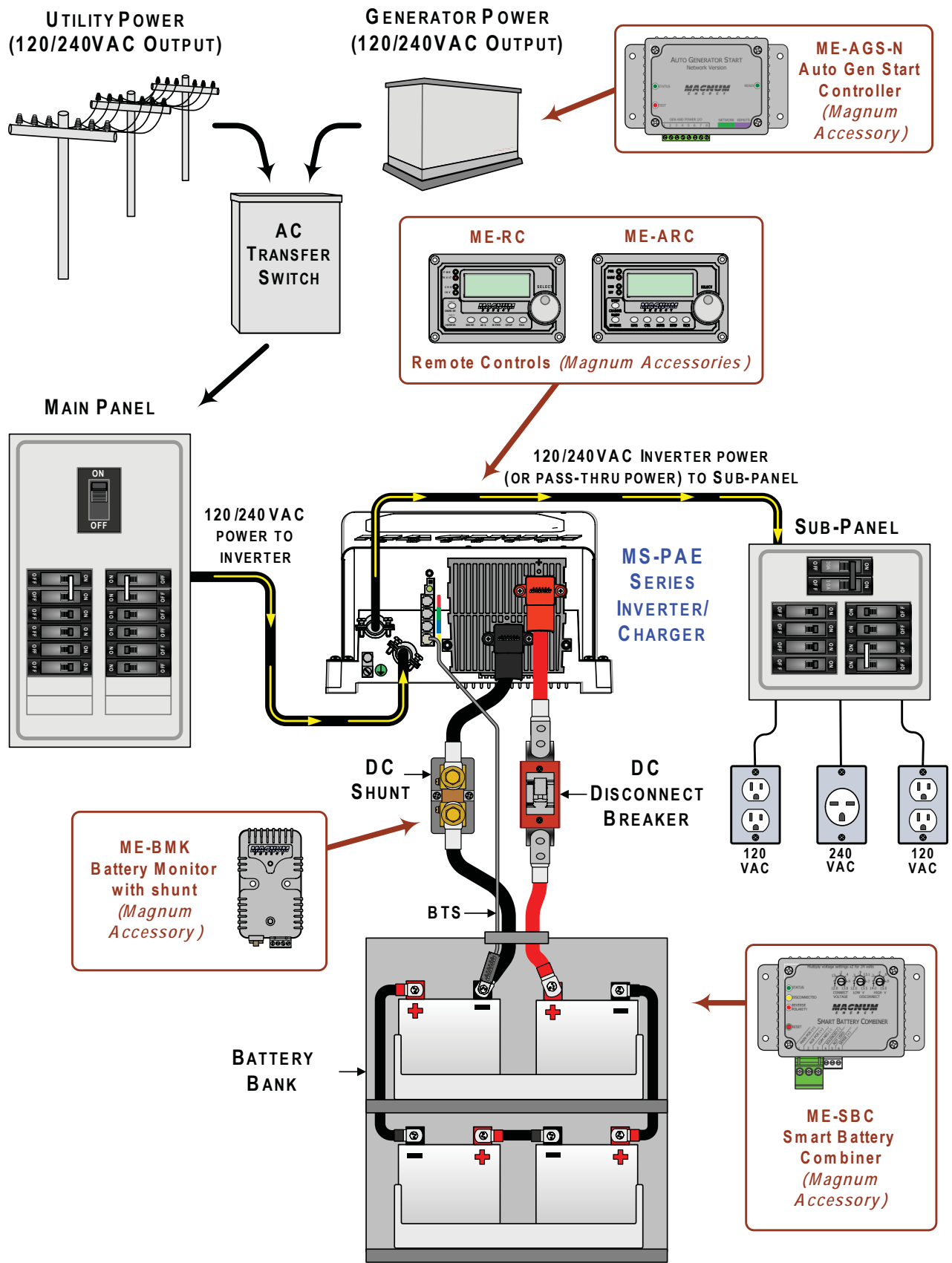

Figure 2-1, Simplified Installation Diagram - Single Inverter

Installation

2.1.3 Locating the Inverter

Only install the inverter in a location that meets the following requirements:

Clean and Dry - The inverter should not be installed in an area that allows dust, fumes, insects or rodents to enter or block the inverter's ventilation openings. This area also must be free from any risk of condensation, water or any other liquid that can enter or fall on the inverter. The inverter uses stainless steel fasteners, plated copper buss-bars, a power-coated aluminum base and the internal circuit boards are conformal coated all done to help fight the harmful effects of corrosive environments. However, the life of the inverter is uncertain if used in these type of environments, and inverter failure under these conditions is not covered under warranty.



Info: If the inverter is installed in an area where moisture may occur, we recommend putting silicone dielectric grease compound into the RJ45/RJ11 electrical ports (items 3 - 6 as shown in figure 1-1). Before installing the accessory cables or if leaving any ports open, squirt a liberal amount into each port. Silicone dielectric compound makes an effective moisture barrier to help prevent corrosion.

Cool - The inverter should be protected from direct sun exposure or equipment that produces extreme heat.



Info: The ambient temperature around the inverter must not exceed 77°F (25°C) to meet power specifications.

Ventilation - In order for the inverter to provide full output power and avoid overtemperature fault conditions; do not cover or block the inverters ventilation openings or install this inverter in an area with limited airflow. The inverter uses two internal fans to provide forced air cooling, these fans pull in air through the intake vents (see item 9 in figure 1-2) and blow out air through the exhaust vents (see item 13 in figure 1-3). Allow at the minimum, an airspace clearance of 6" at the intake and exhaust vents and 3" everywhere else to provide adequate ventilation.

If the inverter is installed in an enclosure, a fresh air intake opening must be provided directly to the front side (intake vents) of the inverter and an exhaust opening on the back side (exhaust vents) of the inverter. This will allow cool air from the outside to flow into the inverter and heated air to exit from the inverter and out of the enclosure. When mounted in an enclosed compartment, airflow must be at least 100 cfm in order to maintain no more than a 68°F (20°C) rise in compartment temperature.



CAUTION: Do not install this inverter in a zero clearance compartment. Do not cover or obstruct the ventilation openings - overheating may result.

Safe - Keep any flammable/combustible material (i.e. paper, cloth, plastic, etc.) that may be ignited by heat, sparks or flames at a minimum distance of 2 feet away from the inverter. Do not install this inverter in any area that contains extremely flammable liquids like gasoline or propane, or in locations that require ignition-protected devices.

Close to the battery bank - As with any inverter, it should be located as close to the batteries as possible. Long DC wires tend to loose efficiency and reduce the overall performance of an inverter. However, the unit should not be installed in the same compartment as the batteries or mounted where it will be exposed to gases produced by the batteries. These gases are corrosive and will damage the inverter; also if these gases are not ventilated and if allowed to collect, they could ignite and cause an explosion. The absolute maximum recommended battery cable length is 15 feet.

Accessible - Do not block access to the inverter's remote control and accessory ports as well as the inverter's controls and status indicator. Also allow enough room to access the AC and DC wiring terminals and connections, as they will need to be checked and tighten periodically. See figure 2-3 for the MS-PAE Series inverter/charger dimensions.

Away from sensitive electronic equipment - High powered inverters can generate levels of RFI (Radio Frequency Interference). Locate any electronic equipment susceptible to radio frequency and electromagnetic interference as far away from the inverter as possible.

2.1.4 Mounting the Inverter

The inverter base can reach a temperature up to 90°C (194°F), and it is recommended that it should be mounted on a noncombustible surface*. This surface and the mounting hardware must also be capable of supporting at least twice the weight of the inverter. To meet regulatory requirements, the MS-PAE Series must be mounted in one of the following positions; as shown in figure 2-2:

- above or under a horizontal surface (shelf or table),
- or on a vertical surface (wall) with the DC terminals to the right.
- or on a vertical surface (wall) with the DC terminals toward the bottom with the MP-HOOD (inverter hood) installed over the exhaust vents (top) and either the ME-CB (Conduit box), MMP Series (single inverter enclosure), or MP Series (multiple inverter enclosure) is attached to the inverter's DC end (bottom).



Info: The ME-CB, MMP Series and MP Series enclosures prevent material from falling out the bottom in the event of an internal fire and also allow sufficient ventilation to prevent the inverter from overheating under normal operating conditions. The MP-HOOD inverter hood helps prevent items from falling inside causing damage to the inverter.



Info: Magnum provides a backplate with a suitable surface for mounting the inverter. These backplates also provide the ability to mount either the MMP Series enclosure (PN: BP-MMP) or the MP Series Enclosure (PN: BP-S, Single Plate or BP-D, Dual Plate).

After determining the mounting position, refer to the physical dimensions as shown in figure 2-3 or use the base of the inverter as a template to mark your mounting screw locations. After marking the mounting screw locations, mount the unit with appropriate mounting hardware.

* Noncombustible surface - A surface made of material that will not ignite, burn, support combustion, or release flammable vapors when subjected to fire or heat as per the ASTM E136 standard. For the most part, these are materials that are largely comprised of inorganic materials such as stone, steel, iron, brick, tile concrete, slate and glass. Common building materials such as gypsum board as well as any paint, wall cov-

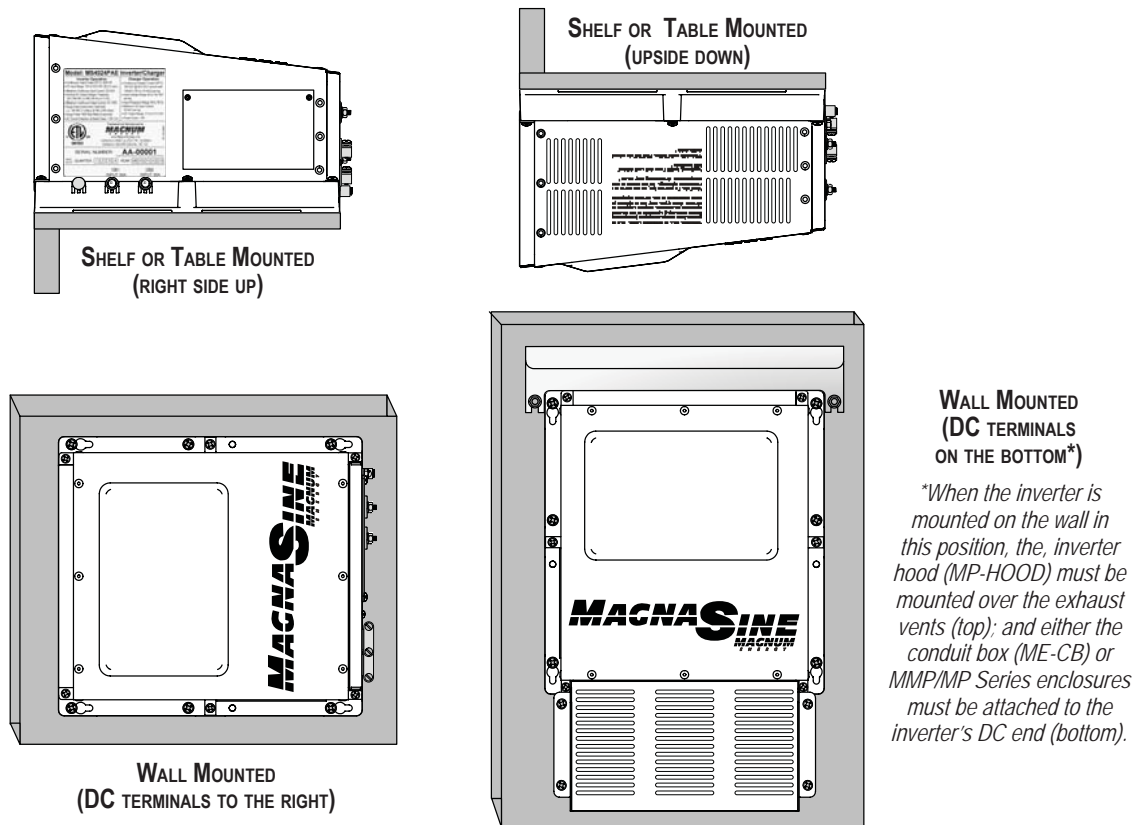

Figure 2-2, Approved Mounting Positions

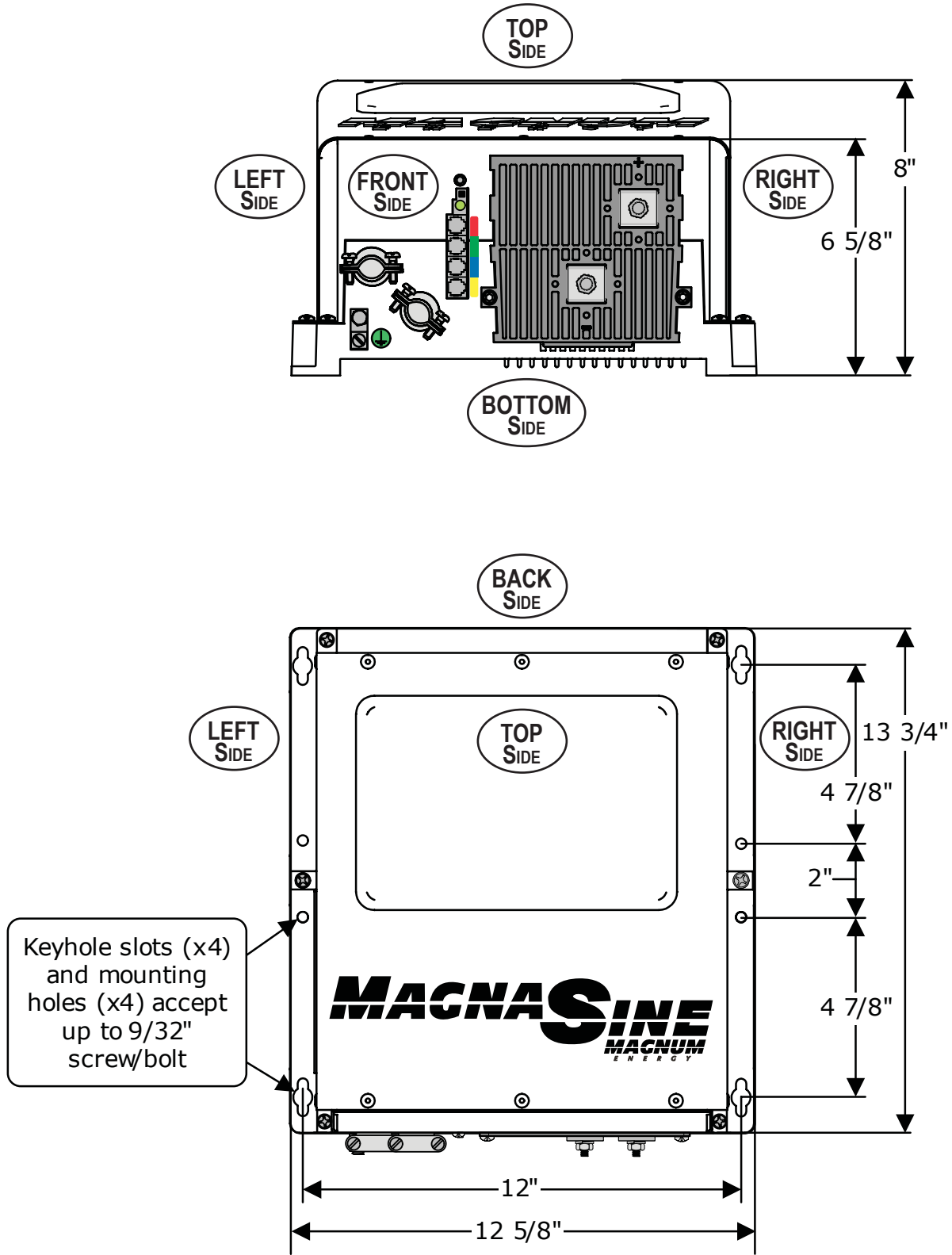

Figure 2-3, MS-PAE Series Dimensions

2.1.5 Wiring the Inverter

This section also describes the requirements and recommendations for wiring the MS-PAE Series Inverter/Charger. Before wiring the MS-PAE Series inverter/charger, read all instructions.

All wiring should meet all local codes and standards and be performed by qualified personnel such as a licensed electrician.

The NEC (National Electric Code, ANSI/NFPA 70) for the United States and the CEC (Canadian Electrical Code) for Canada provide the standards for safely wiring residential and commercial installations. The NEC/CEC lists the requirement for wire sizes, overcurrent protection and installation methods and requirements.

Inverter/charger systems involve power from multiple sources (inverter, generator, utility, batteries, solar arrays, etc.) which make the wiring more hazardous and challenging.

The input and output AC and DC circuits are isolated from the inverter chassis. The inverter system grounding is the responsibility of the installer in accordance with the NEC.



WARNING: Ensure all sources of DC power (i.e. batteries, solar, wind or hydro) and AC power (utility power or AC generator) are de-energized (i.e. breakers opened, fuses removed) before proceeding - to prevent accidental shock.

2.1.6 Protecting Wire - Conduit Box or Inverter Enclosure

The AC and DC wires into and out of the inverter must be protected by rigid tubing, as required by code to comply with residential and commercial installations. This is normally done by feeding the wires through conduit. Magnum provides a DC conduit box (ME-CB), a single inverter enclosure (MMP Series), or a multiple inverter enclosure (MP Series) that includes the necessary AC and DC inverter breakers that can be purchased to allow both the AC and DC conduit to be connected to the inverter.

2.1.7 Wiring Requirements

- All conductors that are at risk to physical damage must be protected by conduit, tape, or placed in a raceway.
- Always check for existing electrical, plumbing or other areas of potential damage prior to making cuts in structural surfaces or walls.
- Both AC and DC overcurrent protection must be provided as part of the installation.
- The inverter requires a reliable negative and ground return path directly to the battery.
- Use only copper wires with a minimum temperature rating of 90°C.

2.1.8 Wire Routing

Before connecting any wires, determine all wire routes throughout the home to and from the inverter. Typical routing scenarios are:

- AC input wiring from the main AC panel to the inverter
- AC input wiring from a generator (optional) to the inverter
- DC input wiring from the batteries to the inverter
- AC output wiring from the inverter to the AC sub-panel or to dedicated circuits
- Battery Temperature Sensor cable from the inverter to the batteries
- Remote Control cable (optional) to the inverter
- Ground wiring from the inverter to an external ground

2.1.9 Torque Requirements

Torque all AC wiring connections to 16 in lbf (1.8 Nm). Torque DC cable connections from 10 to 12 ft lbf (13.6 to 16.3 Nm).

Installation

2.2 Grounding Inverters

The MS-PAE Series inverters use two separate electrical systems (AC and DC power), therefore **each** electrical system is required to be properly connected to a permanent, common "ground" or "earth" reference. An inverter system that is properly grounded limits the risk of electrical shock, reduces radio frequency noise and minimizes excessive surge voltages induced by lightning. To understand how the conductors in the electrical circuit will be connected to the system ground, the following terms should be understood (also refer to figure 2-4):

- **Grounded Conductor (GC):** The wire/cable in the electrical system that normally carries current (usually the AC neutral and/or the DC negative); and is intentionally connected or "bonded" to the ground system. This wire or the ends of this wire should be colored white or gray.
- **Equipment Grounding Conductor (EGC):** A wire/cable that does not normally carry current and is used to connect the exposed metal parts of equipment - that might be accidentally energized - to the grounding electrode system or the grounded conductor. This wire or the ends of this wire should be green or green with a yellow stripe; or this wire can be bare copper.
- **Grounding Electrode Conductor (GEC):** The wire/cable that does not normally carry current and connects the grounded conductor and/or the equipment grounding conductor to the grounding electrode at the service equipment.
- **Grounding Electrode (GE):** A ground rod or conducting element that establishes an electrical connection to the earth or common ground reference.
- **System bonding jumper (SBJ)** The connection between the grounded circuit conductor in the electrical system and the equipment grounding conductor at a separately derived system.

There are two types of grounding - equipment grounding and system grounding.

The exposed metal parts of the equipment in the system usually don't carry electricity. However, if the exposed metal becomes electrified by a live wire, a person touching this live part could complete the electrical circuit and receive a shock. Equipment grounding prevents shock by connecting all the exposed metal parts of equipment (via Equipment Grounding Conductors - EGC) together at a common ground point (Ground Bus-Bar - GBB). This common ground point - installed in the service disconnect panel for each electrical system (AC and DC) - is then connected (via Grounding Electrode Conductor - GEC) to the common ground reference, such as a ground rod (Grounding Electrode - GE). This connection to earth is made at only one point in each electrical system; otherwise, parallel paths will exist for the currents to flow. These parallel current paths would represent a safety hazard and are not allowed in installations wired per the NEC/CEC.

System grounding takes one of the current-carrying conductors (Grounded Conductor - GC) and attaches it to the common ground point (Ground Bus-Bar - GBB) usually by a System Bonding Jumper (SBJ) in each electrical service disconnect panel. On the DC side that is the negative conductor; on the AC side it's the neutral conductor. The closer the grounding connection is to the source, the better the protection from surges due to lightning.

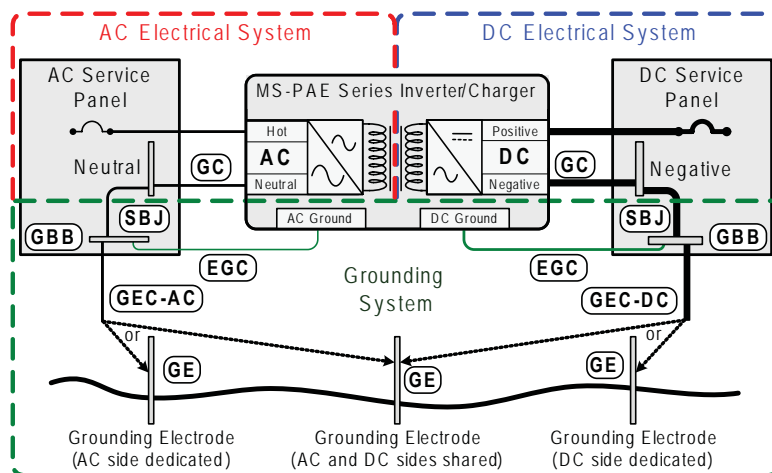

Figure 2-4, Grounding System for MS-PAE Series

2.2.1 Sizing the Grounding Electrode Conductors

AC Side - The size of the AC Grounding Electrode Conductor (GEC -AC) depends on the size of the largest ungrounded conductor feeding the AC load center. A #8 AWG (8.4 mm²) copper conductor will serve as an AC Grounding Electrode Conductor (GEC -AC) for AC power conductors smaller than and including #2 AWG (33.6 mm²) copper. See Table 2-1 for additional values.

Table 2-1, AC Grounding Electrode Conductor Sizing

AC Grounding Electrode Conductor Sizing	
Size of Largest Ungrounded Conductor (Copper)	Minimum Size of Grounding Electrode Conductor (Copper)
2 AWG or smaller	#8 AWG
1 or 1/0 AWG	#6 AWG
2/0 or 3/0 AWG	#4 AWG
Over 3/0 AWG through 350kcmil	#2 AWG

DC Side - To size the DC Grounding Electrode Conductor, you must first determine which one of the following three methods will be used to connect the DC and AC grounding points in the inverter's two electrical systems to the common "earth" ground:

Method 1 (see figure 2-5): This method uses a separate Grounding Electrode for the DC system and the AC system. In this method - since there are multiple connections to the DC Grounding Electrode (GEC - DC) - the size of the DC Grounding Electrode Conductor cannot be smaller than the largest conductor in the DC system (usually the battery-to-inverter cable).

The DC Grounding Electrode (GE - DC) must be bonded to the AC Grounding Electrode (GE - AC) to make a grounding electrode system; this bonding conductor (BC) cannot be smaller than the largest Grounding Electrode Conductor, either AC or DC.

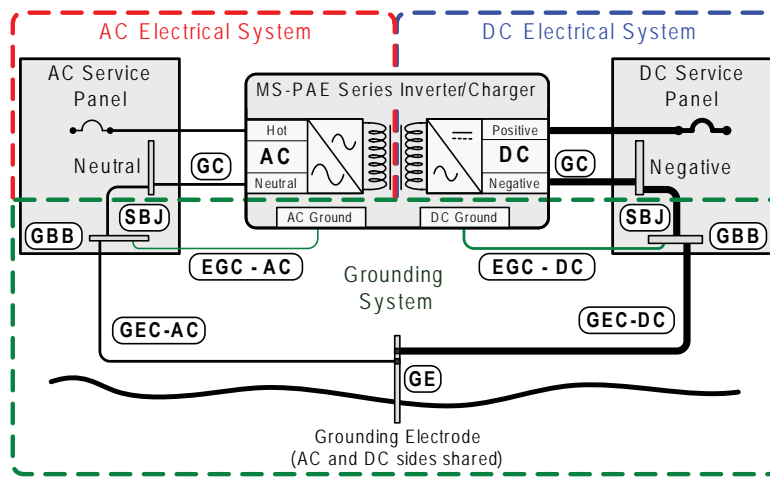

Figure 2-5, Multiple Connections to DC Ground Rod (Method 1)

Installation

Method 2 (see figure 2-6): When the AC and DC service panels are near each other, then the AC Grounding Electrode Conductor (GEC – AC) and DC Grounding Electrode Conductor (GEC – DC) can be connected to a single Grounding Electrode. In this method - since there are multiple connections to the DC Grounding Electrode (GEC – DC) - the size of the DC Grounding Electrode Conductor can not be smaller than the largest conductor in the DC system (usually the battery-to-inverter cable).

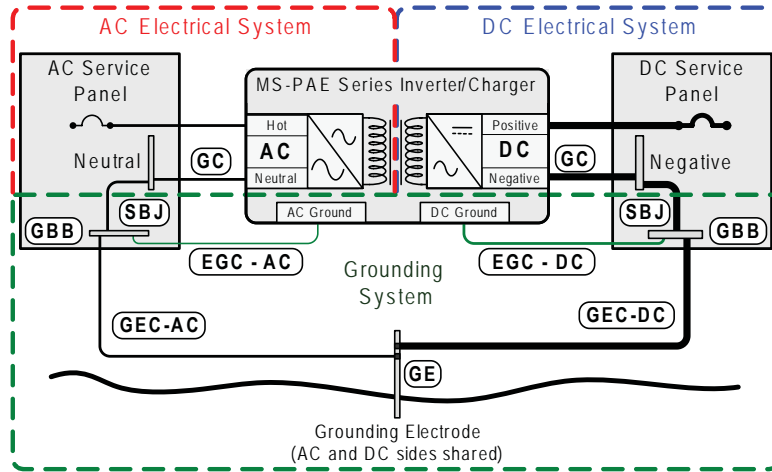

Figure 2-6, Multiple Connections to DC Ground Rod (Method 2)

Method 3 (see figure 2-7): The AC Grounding Electrode Conductor (GEC – AC) is bonded to the DC ground point and the DC Grounding Electrode Conductor (GEC – DC) is the *only* connection to the Grounding Electrode, which must be a rod, pipe, or plate electrode.

In this method, since there is only one connection to the ground rod, the DC Grounding Electrode Conductor is not required to be larger than #6 AWG (13 mm²) copper. The reasoning for allowing this smaller grounding electrode conductor is that it is only required to stabilize the system voltage with respect to earth and the other properly-sized conductors in each electrical system will safely carry any fault currents if they occur.

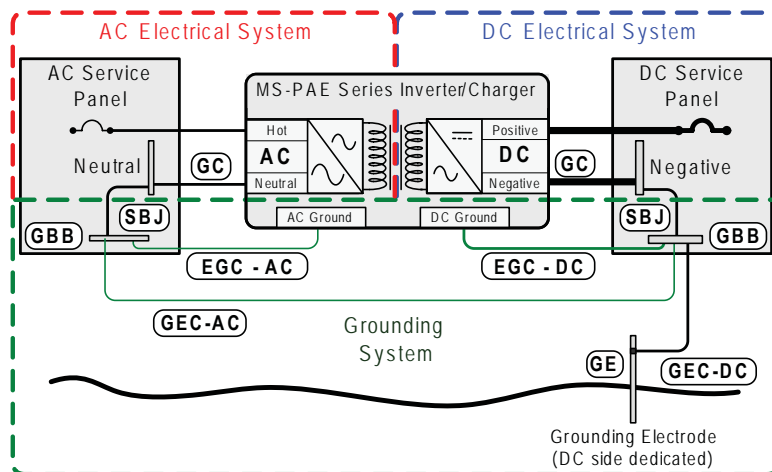

Figure 2-7, Single Connection to DC Ground Rod (Method 3)

2.2.2 System Bonding Jumper

The MS-PAE Series inverter does not include an internal bond between the Grounded Conductor (AC neutral/DC negative) and the equipment grounding terminals. This bond [System Bonding Jumper (SBJ)] is usually done in the main distribution panel for each electrical system.



CAUTION: There should be one and only one point in each electrical system (both AC and DC) where the Grounded Conductor is attached to the Grounding Electrode Conductor.

AC Side – The size of the System Bonding Jumper (SBJ) in the AC electrical system is based on the area of the largest AC ungrounded conductor. In accordance with the NEC, use Table 2-1 to determine the System Bonding Jumper size compared to the largest AC ungrounded conductor.

DC Side - The size of the System Bonding Jumper (SBJ) in the DC electrical system must not be smaller than the DC Grounding Electrode Conductor (GEC – DC) used, which is determined from the grounding method that will be used (see section 2.2.1).

2.2.3 Equipment Grounding Conductor

The inverter case and all other non-current-carrying exposed metal surfaces in the entire electrical system that may be accidentally energized must be grounded. The equipment-grounding conductor must be sized to safely carry the maximum ground-fault current likely to be imposed on it from where a ground-fault may occur. In accordance with the NEC, use Table 2-2 to size the equipment-grounding conductors. This table requires that the equipment-grounding conductor be sized according to the rating of the overcurrent device protecting the circuit.



CAUTION: The connections and wiring for the equipment-grounding conductor must be continuous to allow fault currents to properly operate overcurrent devices. Where equipment is removed and this disconnects the bonding connection between the grounding electrode conductor and exposed conducting surfaces, a bonding jumper must be installed while the equipment is removed.

AC Side - Where the AC output from the inverter is connected to an AC load center, there should be an equipment grounding conductor connected between the inverter case and the grounding point in the AC load center. The AC Equipment Grounding Conductor (EGC – AC) is sized per Table 2-2 and is connected to the inverter’s AC equipment grounding terminal shown in figure 2-12.

DC Side - Since the currents on the DC side are higher than the AC side (5 times at 24 volts, 2.5 times at 48 volts), the equipment grounding needs are different. The DC Equipment Grounding Conductor (EGC – DC) is sized per Table 2-2 and connected to the DC equipment grounding terminal on the inverter shown in figure 1-2 (item 12).

Table 2-2, Equipment Grounding Conductor Sizing

Equipment Grounding Conductor Sizing	
Rating of Overcurrent Device	Minimum Size of Copper Ground Wire
15 amp	#14 AWG
20 amp	#12 AWG
30 - 60 amp	#10 AWG
100 amp	#8 AWG
200 amp	#6 AWG
300 amp	#4 AWG
400 amp	#3 AWG

Installation

2.3 DC Wiring

This section describes the inverter's required DC wire sizes and the recommended disconnect/over-current protection and how to make the DC connections to the inverter and the battery bank.

Refer to figure 2-8 when connecting the DC wires.



WARNING: Even though DC voltage is "low voltage", significant hazards may be present, particularly from short circuits of the battery system.



CAUTION: The inverter is NOT reverse polarity protected which means that if the negative and positive battery voltage is connected backwards to the inverter, the inverter will likely be damaged. You should verify the correct voltage polarity using a voltmeter BEFORE connecting the DC wires.



Info: DO NOT connect the battery cables to the inverter until all wiring is complete and the correct DC voltage and polarity has been verified.



CAUTION: Before wiring the DC cables, review the safety information at the beginning of this manual and the following to ensure a safe and long-lived system:

- When the inverter is installed in a Photovoltaic System, the NEC requires that the DC circuit conductors and overcurrent devices to the inverter be sized to carry not less than 125 percent of the inverter's maximum current rating.
- The DC positive and negative cables connected to the inverter from the battery bank should be tied together with wire ties or electrical tape approximately every 6 inches. This helps improve the surge capability and reduces the effects of inductance, which improves the inverter waveform and reduces the wear of the inverter's filter capacitors.
- Crimped and sealed copper ring terminal lugs with a 5/16" hole should be used to connect the DC wires to the inverter's DC terminals.
- The battery bank voltage MUST match the DC voltage required by the inverter (i.e. 24-volt battery bank for a 24-volt inverter) or the inverter may be damaged.
- To ensure the maximum performance from the inverter, all connections from the battery bank to the inverter should be minimized, the exception is the DC overcurrent disconnect in the positive line and a shunt in the negative line. Any other additional connection will contribute to additional voltage drops and these extra connections points may loosen during use.
- All wiring to the battery terminals should be checked periodically (once a month) for proper tightness. The torque requirement for the DC terminals is between 10 to 12 ft lbf (13.6 to 16.3 Nm). If you don't have a torque wrench, ensure all DC terminals are tight and cannot move.
- Be aware that overtightening or misthreading the nuts on the DC terminals can cause the bolts to strip and snap/break off.
- Make sure cables have a smooth bend radius and do not become kinked. Place long cable runs in conduit and follow existing wire runs where possible.
- A brief spark or arc may occur when connecting the battery cables to the inverter DC terminals; this is normal and due to the inverter's internal capacitors being charged.
- Color code the DC cables/wires with colored tape or heat shrink tubing: RED for positive (+); WHITE for negative (-); and GREEN for DC ground to avoid polarity problems.

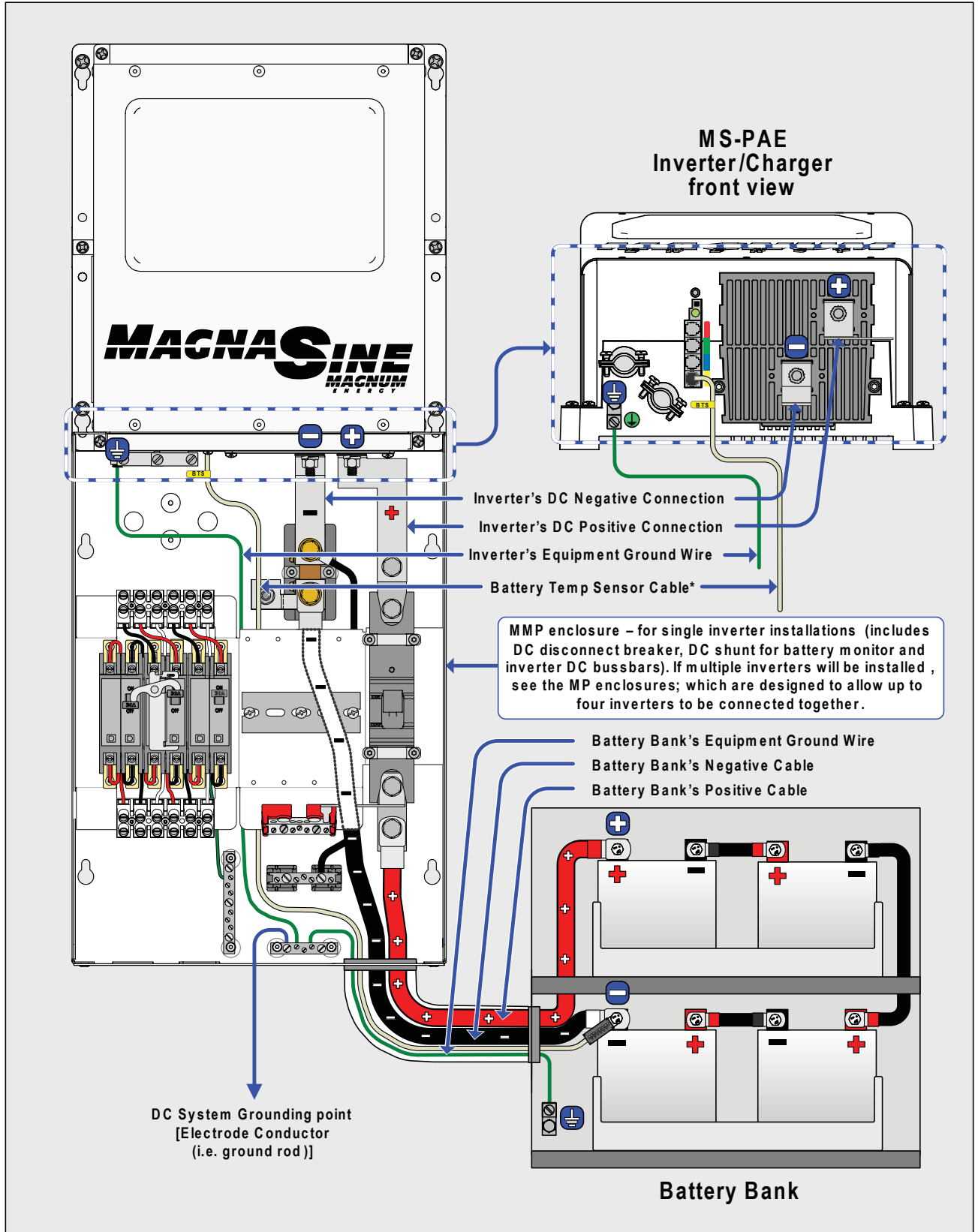

Figure 2-8, DC and Battery Temperature Sensor Wiring

Installation

2.3.1 DC Wire Sizing

It is important to use the correct DC wire to achieve maximum efficiency from the system and reduce fire hazards associated with overheating. Always keep your wire runs as short as practical to help prevent low voltage shutdowns and keep the DC breaker from nuisance tripping (or open fuses) because of increased current draw. See Table 2-3 to select the minimum DC wire size (and corresponding overcurrent device) required based on your inverter model. The cable sizes listed in Table 2-3 for your inverter model are required to reduce stress on the inverter, minimize voltage drops, increase system efficiency and ensure the inverter's ability to surge heavy loads.

If the distance from the inverter to the battery bank is greater than 5 feet, the DC wire will need to be increased. Longer distances cause an increase in resistance, which affects the performance of the inverter. Continue to use the overcurrent device previously determined from Table 2-3 and then refer to Table 2-4 to determine the minimum DC wire size needed for various distances based on your inverter model.

2.3.2 DC Overcurrent Protection

For safety and to comply with electrical code regulations, you must install a DC overcurrent protection device in the positive DC cable line to protect your DC cables. This DC overcurrent device can be a fuse or circuit breaker and must be DC rated. It must be correctly sized according to the size of DC cables being used, which means it is required to open before the cable reaches its maximum current carrying capability, thereby preventing a fire. In a residential or commercial electrical installation, the NEC requires both overcurrent protection and a disconnect switch. If a circuit breaker is used as the overcurrent protection device, it can also be used as the required DC disconnect.

If a fuse is used as an overcurrent device, a Class-T type or equivalent is recommended. This fuse type is rated for DC operation, can handle the high short-circuit currents and allow for momentary current surges from the inverter without opening. However, because the fuse can be energized from both directions, if it is accessible to unqualified persons, the NEC requires that it be installed in a manner that the power can be disconnected on both ends of the fuse before servicing.

See Table 2-3 to select the DC overcurrent device needed based on the minimum wire size according to your inverter model.

Table 2-3, Recommended DC Wire/Overcurrent Device

Inverter Model	Maximum Continuous Current ¹	NEC Current ²	Recommended DC Wire Size ³ (conduit rating)	Recommended DC Overcurrent Device	DC Grounding Electrode Wire Size ⁵
MS4024PAE	222 amps	278 amps	#4/0 AWG (260 amps)	250 amps ⁴	#6 AWG
MS3748PAEJ	102 amps	128 amps	#2/0 AWG (195 amps)	175 amps	#6 AWG
MS4448PAE	122 amps	153 amps	#2/0 AWG (195 amps)	175 amps	#6 AWG

Note 1 - Maximum Continuous Current is based on continuous power rating at the lowest input voltage.

Note 2 - NEC Current is based on the Maximum Continuous Current rating with a 125% NEC de-rating for sizing the overcurrent device (when not continuous duty) to prevent it from being operated at more than 80% of rating.

Note 3 - Copper wire rated with 90°C (194°F) insulation at an ambient temperature of 30°C (86°F), with a multiple cable fill factor (0.8) de-rating (if needed).

Note 4 - The next larger standard size overcurrent device may be used if the derated cable ampacity falls between the standard overcurrent device sizes found in the NEC.

Note 5 - Per the NEC, the DC grounding electrode conductor can be a #6 AWG conductor if that is the only connection to the grounding electrode and that grounding electrode is a rod, pipe, or plate electrode.

Table 2-4, DC Wire Size For Increased Distance

	Minimum Recommended DC Wire Size (one way)*		
	5 ft or less	5 to 10 ft	10 to 15 ft
MS4024PAE	#2/0 AWG x 2	#4/0 AWG x 2	not recommended
MS3748PAEJ & MS4448PAE	#2/0 AWG	#4/0 AWG	#4/0 AWG x 2

* Copper wire rated with 90°C (194°F) insulation at an ambient temperature of 30°C (86°F).

2.3.3 DC Cable Connections

Do not put anything between the DC cable ring lug and the battery terminal post or the flat metal part of the inverter’s DC terminal. When connecting the DC cable to the battery or inverter DC terminals, the cable should be placed directly against the inverter or battery terminals. Incorrectly installed hardware causes a high resistance connection which could lead to poor inverter/charger performance and may melt the cable and terminal connections.

Follow figures 2-9 and 2-10 on how to connect the DC cables and stack the hardware correctly. Tighten the terminal connections from 10 to 12 ft lbf (13.6 to 16.3 Nm).



CAUTION: The DC terminal bolt and nut are made of stainless steel which have a high likelihood of seizure. To help prevent the bolt and nut from seizing - causing the bolt to strip or snap/break-off - the use of anti-seize lubricant is highly recommended.



Info: If antioxidant grease or spray is used, apply it after all the connections have been made and are properly tighten.



Info: A 1/2-inch wrench or socket is used to tighten the 5/16 SAE Flange or Kep nuts.

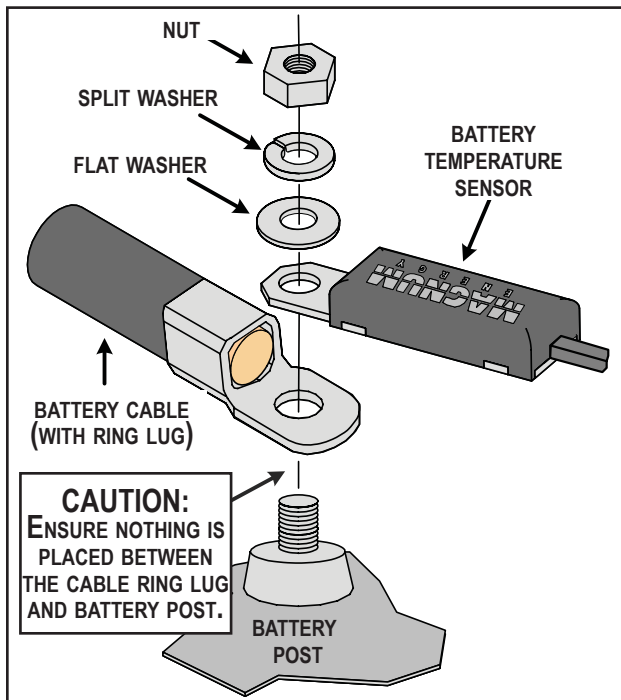

Figure 2-9, Battery Hardware Installation

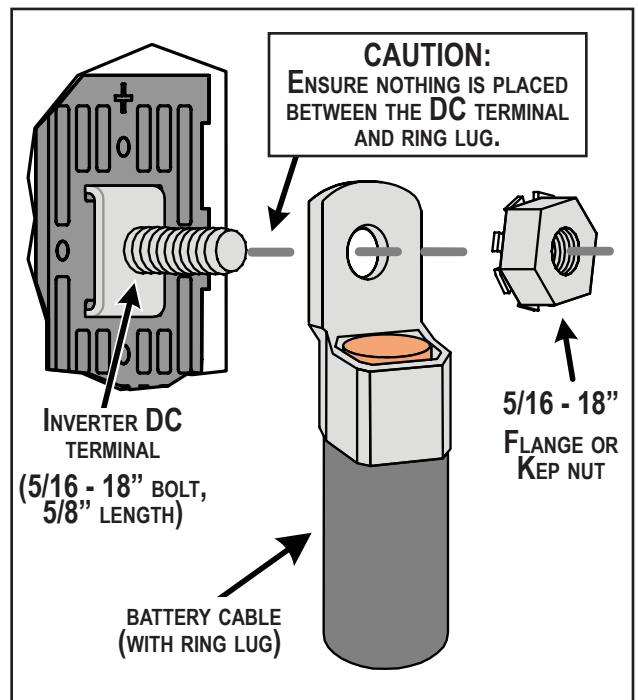

Figure 2-10, Inverter DC Hardware Installation

Installation

2.3.4 Wiring the Battery Bank



WARNING: Lethal currents will be present if the positive and negative cables attached to the battery bank touch each other. During the installation and wiring process, ensure the cable ends are insulated or covered to prevent touching/shorting the cables.



Info: DO NOT connect the DC wires from the battery bank to the inverter until 1) all DC and AC wiring is complete, 2) the correct DC and AC overcurrent protection has been installed and 3) the correct DC voltage and polarity have been verified.



Info: For the MS-PAE Series inverter/charger to perform optimally, a minimum battery bank of 200 AH is recommended for moderate loads (<1000W) and greater than 400 AH for heavy loads ($\geq 1000W$).

Depending upon the type of batteries you use in the installation (6 or 12 VDC), the batteries must be wired in series, parallel or series-parallel to provide the correct voltage (see Appendix C - Battery Wiring, for guidance on wiring batteries together). The interconnecting DC wires must be sized and rated exactly the same as those that are used between the battery bank and the inverter.

Place the batteries as close as practical to the inverter, preferably in an insulated and ventilated enclosure. Allow adequate space above the batteries to access the terminals and vent caps (as applicable). Also allow at least 1" of space between the batteries to provide good air flow. DO NOT mount the batteries directly under the inverter.



Info: To ensure the best performance from your inverter system, batteries should be of the same size, type, rating and age. Do not use old or untested batteries.



CAUTION: Install batteries in a well ventilated area. Batteries can produce explosive gasses. For compartment/enclosure installations, always vent batteries to the outside.

2.3.5 Battery Temperature Sensor Installation and Wiring

The Battery Temperature Sensor (shown in figure 2-11) provides the inverter with precise battery temperature information to automatically adjust the battery charger's BULK, ABSORB and FLOAT voltage setpoints. This allows the batteries to be correctly charged under extreme temperature changes. If the temperature sensor is NOT installed and if the batteries are subjected to large temperature changes, the battery life may be shortened.

To install the BTS:

Attach the ring terminal end of the Battery Temperature Sensor to the negative battery terminal; see figure 2-9 for proper connection to the battery terminal.

Route the sensor's cable to the inverter following existing wire runs.

Connect the RJ11 connector end of the BTS cable to the BTS port (yellow label) on the inverter.

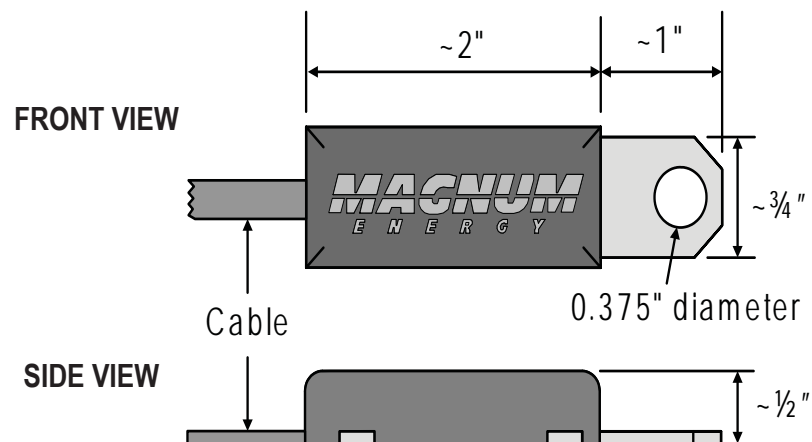

Figure 2-11, Battery Temperature Sensor

2.3.6 Wiring the Inverter to the Battery Bank



CAUTION: Inverter is NOT reverse polarity protected, if this happens the inverter will be damaged and will not be covered under warranty. Before connecting the DC wires from the batteries to the inverter, verify the correct battery voltage and polarity using a voltmeter. If the positive terminal of the battery is connected to the negative terminal of the inverter and vice versa, severe damage will result. If necessary, color code the cables (with colored tape): red for positive (+); black for negative (-) to avoid polarity confusion.



Info: The DC overcurrent device (i.e. circuit breaker) must be placed in the positive (red) DC cable line between the inverter's positive DC terminal and the battery's positive terminal (red); as close to the battery as possible.

DC Ground Wire

Route an appropriately sized DC grounding wire (green or bare wire) from the inverter's DC equipment ground terminal (item 7 in figure 1-2) to a dedicated system ground. Recommended tightening torque is 45 in lbf (5.1 Nm). Refer to section 2.6 for grounding information and sizing the DC ground wires.

DC Negative Wire

Route an appropriately sized DC negative wire (black) from the negative terminal of the battery bank to the inverter's negative terminal (item 11 in figure 1-2).



Info: If installing a battery monitor such as Magnum's ME-BMK, install a DC shunt in-line with the negative battery cable.

DC Positive Wire

Mount the circuit breaker assembly as near as practical to the batteries and open the circuit breaker.



WARNING: DO NOT close the DC circuit breaker to connect battery power to the inverter at this time. This will occur in the **Functional Test** after the installation is complete.



CAUTION: If connecting live battery cables to the inverter DC terminals, a brief spark or arc may occur; this is normal and due to the inverter's internal capacitors being charged.

Route and connect an appropriately sized DC positive wire (red) from the inverter's positive DC terminal (item 10 in figure 1-2) to one end of circuit breaker (or DC fuse block).

Connect a short wire (same rating as the DC wires) to the other side of the DC circuit breaker and the other end of the short wire to the positive terminal of the battery bank (see figure 2-1 for reference). This is essential to ensure even charging and discharging across the entire battery bank.

Ensure the DC wire connections (on the batteries, inverter and DC circuit breaker) are flush on the surface of the DC terminal's and the hardware (lock washer and nut) used to hold these connections are stacked correctly (see figures 2-9 and 2-10). Verify all DC connections are torqued from 10 to 12 ft lbf (13.6 to 16.3 Nm).

Once the DC connections are completely wired and tested, coat the terminals with an approved anti-oxidizing spray.

Attach the red and black terminal covers over the inverter's DC connectors and secure them in place with the supplied screws.

If the batteries are in an enclosure, perform a final check of the connections to the battery terminals, then close and secure the battery enclosure.

Installation

2.4 AC Wiring

This section provides information on how to make the AC connections to the inverter using the correct AC wire size and corresponding overcurrent protection. Refer to figure 2-13 for an overview of the AC wiring.

2.4.1 Pre-AC Wiring Requirements



CAUTION: Before installing any AC wiring, review the safety information at the beginning of this manual and the following to ensure a safe and long-lived system:

- AC Loads powered by the inverter will need to be installed into an electrical panel.
- Read all instructions and cautionary markings located at the beginning of this manual and in the pre-installation section, before installing the inverter and batteries.
- Always use properly rated circuit-breakers. If using an electrical sub-panel, circuit breakers can be moved from the main electrical panel to the sub-panel only if the breakers are also listed to be installed in the sub-panel.
- AC wiring must be no less than #10 AWG (5.3 mm²) gauge copper wire and be approved for residential wiring per the NEC (THHN as an example).
- DO NOT connect the inverter's output to an AC power source.
- Listed or labeled equipment shall be installed and used in accordance with any instructions included in the listing or labeling.

2.4.2 AC Wire Size and Overcurrent Protection

The AC input and output wiring must be sized per the NEC and local electrical safety code requirements to ensure the wires ability to safely handle the inverter's maximum load current. After determining the proper AC wire sizes, the inverter's AC input and output wires are required to be protected from short circuits and overloads by an overcurrent protection device and have a means to disconnect the AC circuits.

Overcurrent protection is not included in the inverter and must be provided as part of the installation. The overcurrent protection device must be a circuit breaker or a fuse and be properly sized and branch circuit rated for the wire it is protecting and the appliances being powered.

The MS-PAE series provides a terminal block (see figure 2-12) that allows the AC input and output wiring to be permanently wired. This terminal block allows a service/distribution panel (main panel) to be wired to the inverter's input and a dedicated panel (sub-panel) between the inverter's output wiring and the AC loads. These systems use the circuit breakers provided in the panels as the overcurrent protection and the AC disconnect device.

When in the Standby mode, the full AC continuous pass-thru capacity of the MS-PAE Series inverter/charger is 30 amps for each AC leg (AC HOT 1 and AC HOT 2). To obtain the 30 amp continuous pass-thru capability of the inverter, each AC HOT input to the inverter requires a 30 amp continuous duty rated double-pole breaker¹, which corresponds to a minimum cable size of #10 AWG² in conduit. If you are using other wire sizes, refer to the appropriate electrical codes for circuit breaker requirements.



CAUTION: The inverter's internal AC transfer relay is rated for 30 amps (each leg), the pass-thru current must be no greater than 30 amps or damage to this relay may occur.

Note 1 - The breaker must be derated by 80% if not rated for continuous duty. The NEC requires that circuits are not to be operated continuously at more than 80% of rating unless listed with a 100% continuous rating.

Note 2 - Copper wire rated with 90°C insulation at an ambient temperature of 30°C (86°F).

2.4.3 Recommended GFCI (Ground Fault Circuit Interruption) Breakers

Some electrical safety codes require the use of GFCI's. In compliance with UL standards, Magnum Energy has tested the following GFCI's and find that they function properly when connected to the inverter's AC output:

- Shock Sentry™ #XGF15V-SP
- Leviton Smart Lock #8899-A
- Hubbel #GF520EMBKA



WARNING: Risk of electric shock. Use only the ground-fault circuit interrupter [receptacle(s) or circuit breaker(s)] specified in this manual. Other types may fail to operate properly when connected to this inverter equipment.

2.4.4 AC Input and Output Wiring Connections

The inverter has a six-connection AC terminal block and two AC ground terminals to connect the Inverter's AC input and output wiring. To access and view the AC terminal block and ground terminals, remove the two Phillips screws holding the AC access cover plate (see figure 1-3, item 15).

Each connection on the AC terminal block is rated for 105°C and can accept one #18 to #2 AWG (0.82 to 33.6 mm²) CU stranded wire; or two #14 to #8 AWG (2.1 to 8.7 mm²) CU stranded wires. Each connection uses a 1/4-28 screw and the maximum tightening torque is 32 in lbf (3.6 Nm).

Each AC ground terminal can accept one #14 to #6 AWG (2.1 to 13 mm²) stranded. Recommended tightening torque is 45 in lbf (5.1 Nm).



Info: The two neutral terminals are common to each other and can be used in any combination or order. In a residential application, it is often easier to only connect one AC neutral wire to the inverter and make the other neutral connections at a central point such as in the AC electrical panel.

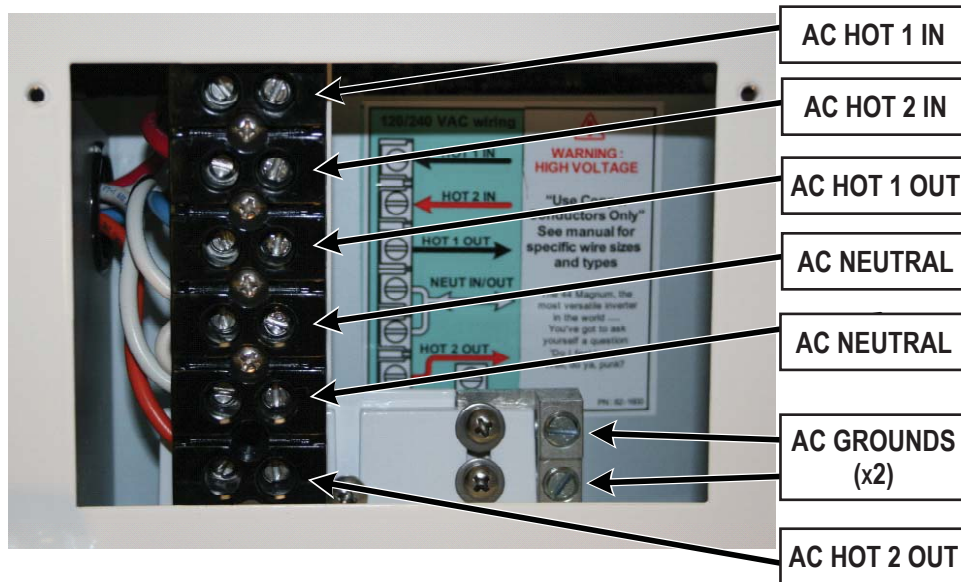

Figure 2-12, AC Terminal Block

Installation

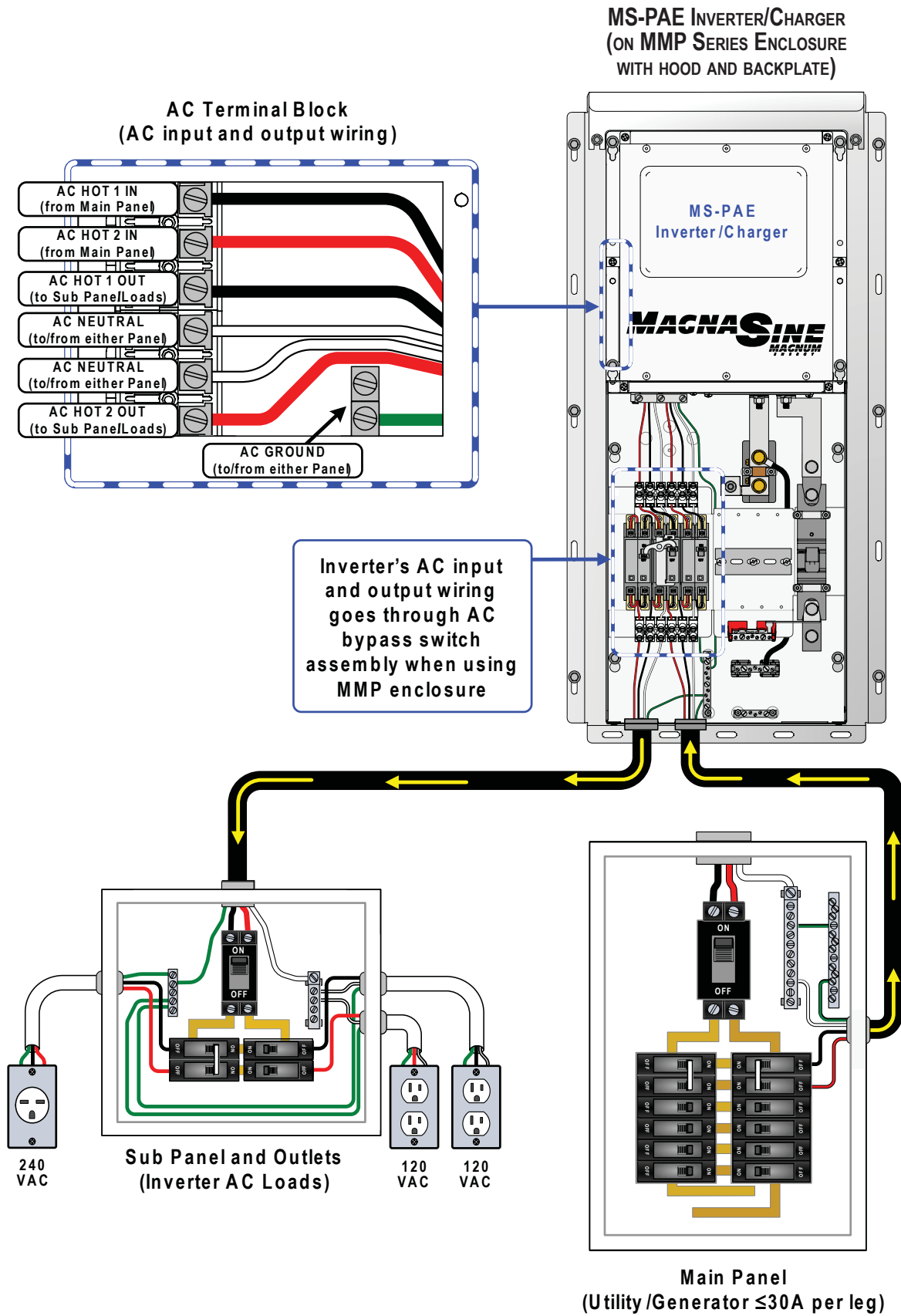

Figure 2-13, AC Wiring

2.4.5 Wiring the AC Input and Output

The MS-PAE series provides 120/240VAC on the output, but the input may be wired either as a 120/240VAC input or a 120VAC input (to one input only) depending on your AC source. The AC output will continue to produce 120/240VAC with either the 120/240VAC or 120VAC input configuration.



WARNING: DO NOT connect 120VAC (same phase) to both AC HOT 1 IN and AC HOT 2 IN inputs. These inputs must be 180° out-of-phase (i.e. 120/240VAC). If you only have a 120VAC source, you may connect to either the AC HOT 1 IN or AC HOT 2 IN, but NOT to both or damage may occur.



WARNING: Before making any AC connections, make sure that the inverter is disconnected from the battery bank and also all AC power is disconnected from the inverter.



CAUTION: The inverter's AC output must never be connected to an AC power source. This could cause severe damage to the inverter and is not covered under warranty.



Info: Torque all AC screw terminals to 16 in lbf (1.8 Nm).

The following steps are a basic guideline for installation and connection of the AC wiring into and out of the inverter (refer to figure 2-13 for the AC wiring installation)

1. Remove the two Phillips screws on the AC wiring compartment cover (item 15 in figure 1-3) to access the internal AC terminal block.
2. If installing an optional enclosure [i.e. ME-CB (Conduit box), MMP Series (single inverter enclosure), or MP Series (multiple inverter enclosure)] to the bottom of the inverter, ensure the knockout(s) that will be used for the conduit are removed. Fasten the conduit to the enclosure using appropriate conduit connectors. Feed all AC wiring through the enclosure and into the inverter AC terminal block; be sure to leave several extra inches of wire to work with. At least two sets of conductor wiring will be needed, one from the AC source (or Main Panel) to the inverter input and another from the inverter output to the sub-panel.

Wiring the Inverter AC Input (from the main panel)

3. a. For a 120/240VAC input: From the main panel's dedicated dual-pole circuit breaker, connect the hot 1 wire (black) to the "AC HOT 1 IN" terminal and the hot 2 wire (red) to the "AC HOT 2 IN" terminal.
- b. For a 120VAC input: From the main panel's dedicated single-pole circuit breaker, connect the hot wire (black) to the "AC HOT 1 IN" or AC HOT 2 IN" terminal, but NOT both or damage may occur.
4. Connect the neutral (white) wire from the main panel's neutral bus bar to one of the "AC NEUTRAL" terminals (both "AC NEUTRAL" terminals are common to each other).
5. Connect the safety ground (green) wire from the main panel's ground bus bar to one of the "AC GROUND" terminals.

Wiring the Inverter AC Output (to the sub-panel)

6. Connect the hot 1 (black) wire to the "AC HOT 1 OUT" terminal and the hot 2 (red) wire to the "AC HOT 2 OUT" terminal.
7. Connect the neutral (white) wire to the open "AC NEUTRAL" terminal.
8. Connect the ground (green) wire to the open "AC GROUND" terminal.
9. After making the AC output connections, route the outgoing AC wires to the appropriate bus-bars in an AC load panel equipped with branch-rated circuit breakers (i.e. sub-panel).

Final Inspection

Gently pull on the wires to ensure they are securely held and ensure no bare wire is exposed.

The AC input and output wiring in the inverter should be complete, prior to reattaching the AC access cover, review all AC wiring to ensure all connections are correct and secure.

Installation

2.5 Inverter Warning Label

A warning label is provided to inform all personnel that an inverter is installed in your electrical system. Affix this label in a clearly visible location at the electrical panel that is being powered by the inverter. This is because it might be falsely assumed that the panel is no longer “hot” after the AC power has been shut off, when power may actually still be available due to the inverter automatically powering the panel.

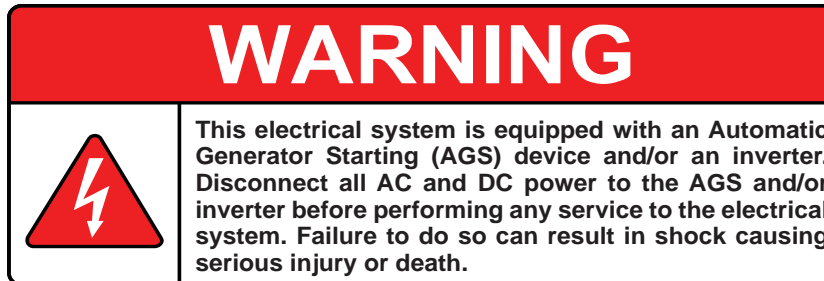

Figure 2-14, Warning Label

2.5.1 Inverter Power Identification and Disconnect Location Requirements

When an inverter is installed in a building, facility or structure, the NEC (National Electrical Code) requires a label or plaque to be provided. This label/plaque is required to be easily visible and provide information that informs personnel on the location of all electrical system disconnects. This is to ensure all power to a building is quickly located and shutdown in an emergency. There are also specific requirements for this label/plaque depending on the inverter application, they are:

(A) Facilities with Standalone Systems. Any building, facility, or structure with a photovoltaic power system that is not connected to a utility service source and is a standalone system must have a permanent plaque or directory installed on the exterior of the building or structure at a readily visible location acceptable to the Authority Having Jurisdiction (AHJ). The plaque or directory must provide the location of system disconnecting means and information regarding whether the structure contains a standalone electrical power system.

(B) Facilities with Utility Services and PV Systems. Buildings, facilities, or structures with both utility service and a photovoltaic system must have a permanent plaque or directory providing the location of the service disconnecting means and the photovoltaic system disconnecting means if they are not located at the same location.

2.6 Functional Test

1. After all electrical connections to the inverter, batteries, AC source, and sub-panel have been completed; follow these steps to test the installation and the inverter operation.



CAUTION: Use a multimeter to verify the correct DC voltage for your particular inverter model (i.e. 48-volt battery bank for a 48-volt inverter) and ensure the polarity of the battery voltage is correct (battery positive connected to inverter positive terminal and negative battery connected to inverter negative terminal).

2. Apply battery power to the inverter by closing the DC circuit-breaker. The inverter will remain OFF, but the green status indicator on the front of the inverter will quickly blink once to indicate that DC power has been connected and is ready to be turned on.

3. Prior to turning on the inverter, make sure all AC loads (i.e. appliances) are NOT connected to the inverter's output or any AC outlets powered by the inverter.

4. Lightly press and release the inverter's ON/OFF switch to turn the inverter ON. Verify the inverter's status indicator is blinking - indicating the inverter is ON.

5. Connect a ≥ 10 watt light bulb to the inverter output and verify it comes on and shines normally. DO NOT connect anything but a light bulb, until all wiring and voltages are confirmed to be correct.



Info: The inverter's AC output voltage will not be correct until a > 5 watt load (5 watts is default setting) is connected to the inverter; or the search mode is turned OFF with a remote display. The 10 watt or greater light bulb is used because it is a sufficient load to bring the inverter out of "search" mode up to full voltage.

6. Check the AC output voltage of the inverter by connecting an AC voltmeter to the output terminals as shown in figure 2-15 and verify the correct output voltages.

7. Press and release the inverter's ON/OFF switch to turn the inverter off. The inverter's status indicator and the connected load should go off.

8. Apply AC power to the inverter's AC input. After the AC input power is qualified (approximately 15 seconds), the incoming AC power will transfer through the inverter to the inverter's AC output and power the light bulb. Verify the inverter's status indicator and the light bulb comes on.

9. Even though the light bulb is on, the inverter is currently disabled (off). Press and release the ON/OFF switch on the inverter to enable (turn-on) the inverter.

10. Disconnect the incoming AC power to the inverter. Verify the light bulb remains on and is now powered by the inverter.

If the inverter passes all the steps, the inverter is ready for use. If the inverter fails any of the steps, refer to the Troubleshooting section.

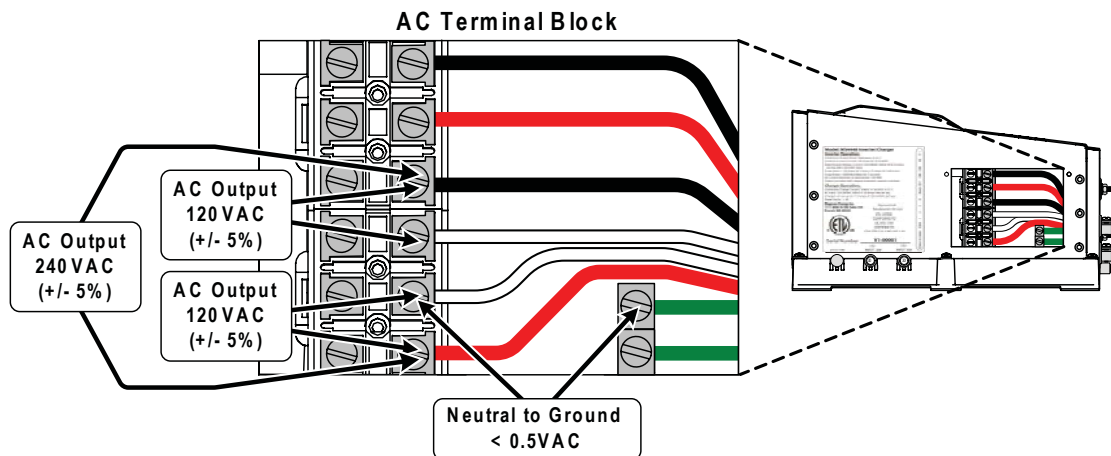

Figure 2-15, AC Voltage Checks

Operation

3.0 Operation

The MS-PAE Series inverter has two normal operating routines; 1. Inverter Mode, which powers your loads using the batteries, and 2. Standby Mode, which transfers the incoming AC Power (i.e. utility power or a generator) to power your loads and uses this incoming power to recharge the batteries. This inverter also includes an extensive protection circuitry to shut-down the inverter under certain fault conditions.

3.1 Inverter Mode

When the MS-PAE series is first powered up, it defaults to the OFF mode. The momentary ON/OFF power switch (item 1 figure 1-1) must be lightly pressed to turn the inverter ON. Subsequently pressing this switch alternately turns the inverter OFF and ON.

Inverter OFF - When the inverter is OFF, no power is used from the batteries to power the AC loads and the status LED will be OFF. If AC power from an external source (Utility or Generator) is connected and qualified on the inverter's AC input, this AC input power will pass through the inverter to power the AC loads. However, if this AC power is lost, the AC loads will no longer be powered because the inverter is OFF.

When the inverter is turned ON, it operates either by "Searching" or "Inverting", depending on the connected AC loads.

Searching - When the inverter is first turned ON, the automatic Search feature is enabled. This feature is provided to conserve battery power when AC power is not required. In this mode, the inverter pulses the AC output looking for an AC load (i.e. electrical appliance). Whenever an AC load (greater than 5 watts) is turned on, the inverter recognizes the need for power and automatically starts inverting. When there is no load (or less than 5 watts) detected, the inverter automatically goes back into search mode to minimize energy consumption from the battery bank. When the inverter is "Searching", the inverter's green LED flashes (fast).



Info: The factory default value for the Search feature is 5 watts, it can be turned off or adjusted from 5 to 50 watts using the ME-RC or ME-ARC remote display.

Inverting - When a load greater than 5 watts is connected to the inverter output, the MS-PAE series "inverts" the DC power from the battery and supplies 120/240VAC power to your sub-panel. The inverter's green LED flashes once every 2 seconds (medium flash) to indicate it is inverting. The amount of time the inverter can be inverting and provide power is directly related to the amount of AC loads that are connected and the capacity of the battery bank. Refer to figure 3-1 to see the flow of power from the DC input to the AC output while in the Inverter Mode.

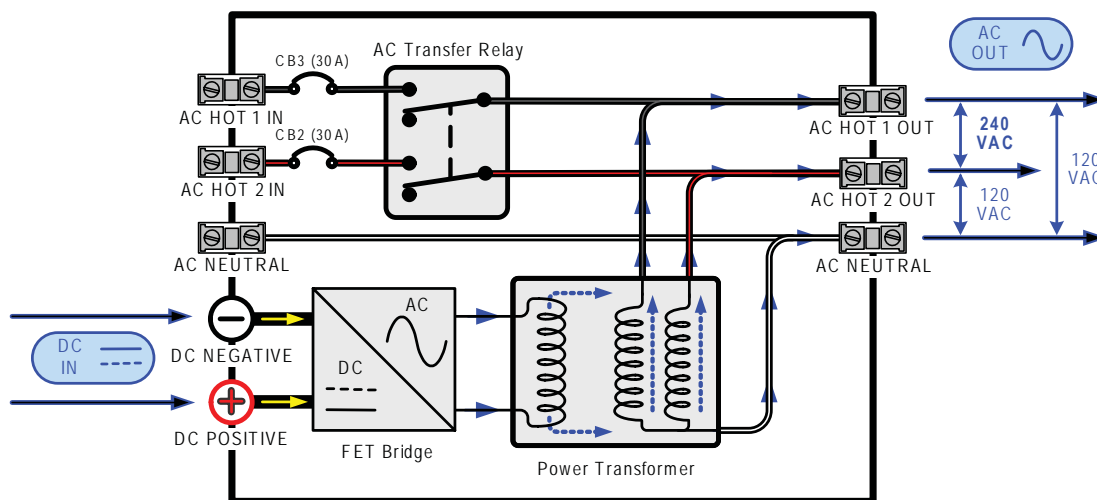

Figure 3-1, Power Flow - Inverter Mode

3.2 Standby Mode

The MS-PAE Series features an automatic transfer relay and an internal battery charger when operating in the Standby Mode. The Standby Mode begins whenever AC Power (Utility or Generator) is connected to the inverter's AC input. Once the AC voltage and frequency of the incoming AC power is within the AC input limits, an automatic AC transfer relay is activated. This transfer relay passes the incoming AC power through the inverter to power the AC loads on the inverter's output. This incoming power is also used to activate a powerful internal battery charger to keep the battery bank charged in case of a power failure. Refer to figure 3-2 to see the flow of power from the AC input to the DC and AC output while in the Standby Mode.

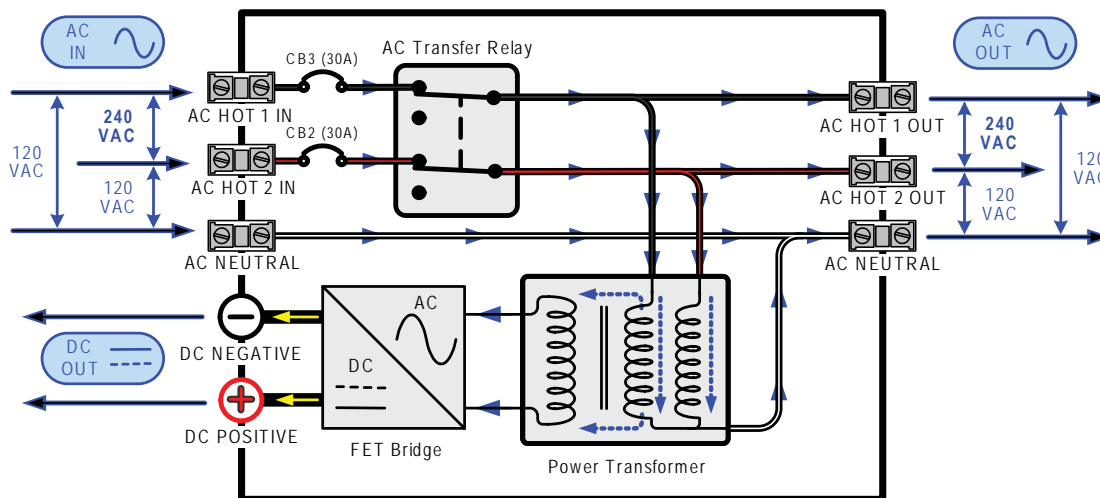

Figure 3-2, Power Flow - Standby Mode

3.2.1 Battery Charging

Magnum Energy's MS-PAE Series is equipped with an active PFC (Power Factor Corrected) and PI (Proportional-Integral) multistage battery charger. The PFC feature is used to control the amount of power used to charge the batteries in order to obtain a power factor as close as possible to 1 (or unity). This causes the battery charger to look like a resistor to the line (forces the charge current waveshape to mirror the voltage waveshape). The PI feature allows the charger voltage and current to change independently. These two features maximize the real power available from either utility or generator AC power sources, which translates into less power wasted and greater charging capabilities than most chargers available today.

When an AC source is connected to the AC input, the inverter begins monitoring for acceptable AC voltage. Once the inverter has accepted this AC voltage, the AC transfer relay closes and the Charge Mode begins. After Charge Mode begins, the DC voltage is monitored to determine the charging stage. If the DC voltage is low (≤ 25.6 / 24-volt models or ≤ 51.2 / 48-volt models), the charger begins Bulk Charging. If the DC voltage is high (>25.6 / 24-volt models or >51.2 / 48-volt models), the charger will skip the Bulk and Absorb charging stages and go directly to Float Charging.

The multistage charger can use up to five different charging stages to help monitor and keep the batteries healthy; The five stage include an automatic 4-stage charging process: Bulk, Absorb, Float and Full Charge; and a manual Equalization (EQ) charge stage. The automatic 4-stage charge process provides complete recharging and monitoring of the batteries without damage due to over charging. The EQ stage (requires the ME-RC remote to enable Equalization charge) is used to stir up stratified electrolyte and try and reverse battery plate sulfation that may have occurred.

While charging, the unit may go into Charger Back-off protection, which automatically reduces the charge current to the batteries. This is caused by: 1. The internal temperature is too hot - the charger automatically reduces the charge rate to maintain temperature; or 2. The AC input voltage falls below 170 VAC (or 85 VAC on either leg) - the charger will stop charging to help stabilize the incoming AC voltage.

Operation

The Charge Mode provides up to four separate charging stages: Bulk Charging, Absorb Charging, Float Charging and Full Charge.

Bulk Charging; This is the initial stage of charging. While Bulk Charging, the charger supplies the battery with controlled constant current. The charger will remain in Bulk charge until the Absorption charge voltage (determined by the Battery Type selection*) is achieved. The inverter's green LED stays ON (solid) to indicate Bulk charging.

Absorb Charging; This is the second charging stage and begins after the absorb voltage has been reached. Absorb Charging provides the batteries with a constant voltage and reduces the DC charging current in order to maintain the absorb voltage setting. The inverter's green LED flashes once every second (fast flash) to indicate absorption charging for 2 hours (determined by the Battery AmpHrs selection*), then switches to Float Charging.

Float Charging; The third charging stage occurs at the end of the Absorb Charging time. While Float charging, the charge voltage is reduced to the float charge voltage (determined by the Battery Type selection*). In this stage, the batteries are kept fully charged and ready if needed by the inverter. The inverter's green LED flashes once every 8 seconds (slow flash) to indicate float charging. The float charging stage reduces battery gassing, minimizes watering requirements (for flooded batteries) and ensures the batteries are maintained at optimum capacity.

Full Charge (Battery Saver™ mode); The fourth stage occurs after four hours in the float charging stage. The Full Charge stage is designed to keep batteries fully charged over long periods and prevent excessive loss of water in flooded batteries or drying out of GEL/AGM batteries. In this stage the charger is turned off and begins monitoring the battery voltage; if the battery voltage drops low (25.4 VDC or less on 24-volt models; or 50.8 VDC or less on 48-volt models), the charger automatically initiates another four hours in Float Charge.



Info: If the battery voltage falls to the re-bulk voltage (24.2V on 24-volt models or 48.4V on 48-volt models) or lower, the unit will begin another Bulk charge.

* These settings in the MS-PAE Series are changeable and leave the factory with default values (see Table 3-2, Inverter/Charger Default Values). These default values are adequate for most installations, however, if you determine that some of the values need to be changed for your particular system, the ME-RC50 remote control may be purchased to adjust these settings.

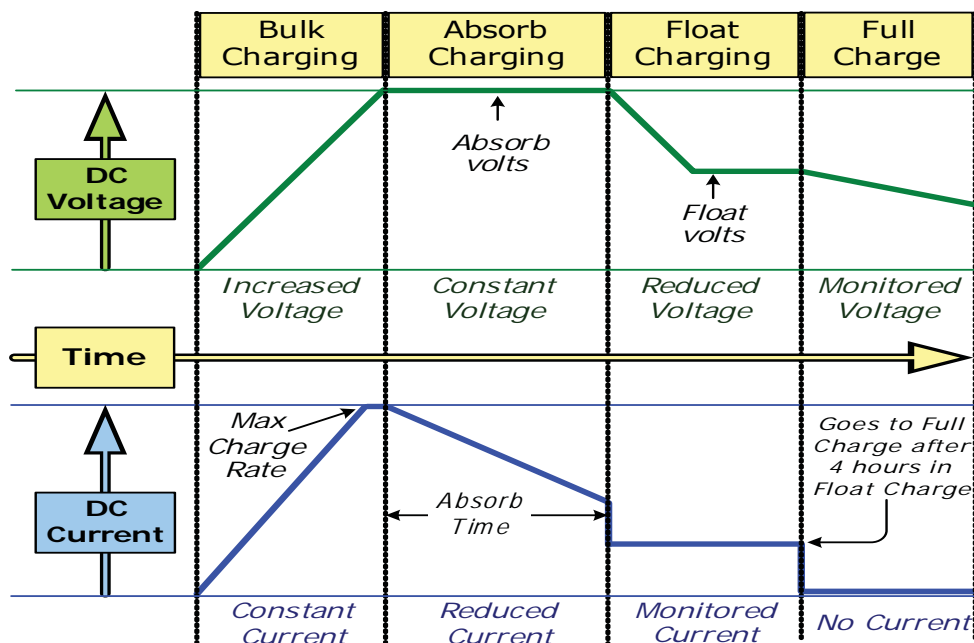

Figure 3-3, Automatic 4-Stage Charging Graph

3.2.2 Transfer Time

While in the Standby Mode, the AC input is continually monitored. Whenever AC power falls below the VAC dropout voltage (80 VAC per leg, default setting), the inverter automatically transfers back to the Invert Mode with minimum interruption to your appliances - as long as the inverter is turned on. The transfer from Standby mode to Inverter mode occurs in approximately 16 milliseconds. While the MS-PAE Series is not designed as a computer UPS system, this transfer time is usually fast enough to hold them up. However, the VAC dropout setting has an effect on the ability of the loads to transfer without resetting. The lower this setting, the longer the effective transfer will be and therefore, the higher the probability for the output loads to reset. This occurs because the incoming AC voltage is allowed to fall to a level that is so low, that when the transfer does occur (in addition to the relay transfer time) the voltage on the inverters output has already fallen low enough level to reset the loads.

The disadvantage of a higher VAC dropout setting is that smaller generators (or large generators with an unstable output) may nuisance transfer. This commonly happens when powering loads that are larger than the generator can handle - causing the generator's output to constantly fall below the inverters input VAC dropout threshold.



Info: When switching from Inverter Mode to the Standby Mode, the inverter waits approximately 15 seconds to ensure the AC source is stable before transferring.

3.3 Battery Temperature Sensor Operation

The plug-in Battery Temperature Sensor (BTS) is used to determine the battery temperature around the batteries, this information allows the multistage battery charger to automatically adjust the battery charge voltages for optimum charging performance and longer battery life.

When the BTS is installed, the charge voltage while in the Bulk, Absorb or Float charge mode will either increase or decrease if the battery temperature is greater or lower than 77°F (25°C). If the temperature around the BTS is below 77°F (25°C) the charge voltage increases and if the temperature around the BTS is higher than 77°F (25°C), the charge voltage decreases. The further the temperature change from 77°F (25°C), the greater the change in the charging voltage. See figure 3-4 to determine how much the charge voltage changes (increases or decreases) depending on the temperature reading of the BTS. For example, the nominal Absorb charge voltage for a flooded battery at 77°F (25°C) on a 24-volt model is 29.2VDC. If the battery temperature is 95°F (35°C), the Absorb charge voltage would decrease to 28.6VDC (29.2 nominal - 0.6 change). If the temperature sensor is NOT installed, the charge voltages will not be compensated and charges at a temperature of 77°F (25°C). Without the BTS installed, the life of the batteries may be reduced if they are subjected to large temperature changes.



Info: The temperature to voltage compensation slope the BTS uses is 5mV/°C/Cell from 0-50°C.

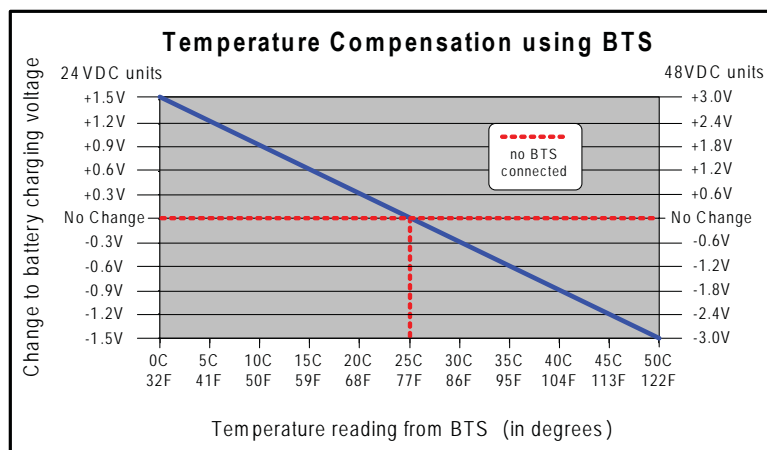

Figure 3-4, BTS Temperature to Charge Voltage Change

3.4 Protection Circuitry Operation

The inverter is protected against fault conditions and in normal usage it will be rare to see any. However, if a condition occurs that is outside the inverter's normal operating parameters, then it will shut down and attempt to protect itself, the battery bank, and your AC loads. If there is a condition that causes the inverter to shutdown, it may be one of the following conditions (also refer to the Troubleshooting section to help diagnose and clear the fault condition).

- **Low Battery** - The inverter will shut off whenever the battery voltage falls to the **LBCO** (Low Battery Cut Out) level to protect the batteries from being over-discharged. After the inverter has reached the LBCO level and turned off, the inverter will automatically restart after one of the following conditions:

1. AC Power is applied and the inverter begins operating as a battery charger.
2. Battery voltage rises to the **LBCI** (Low Battery Cut In) level.

The inverter's status LED turns off when a low battery fault condition occurs. Refer to Table 3-1 to determine the LBCO and LBCI levels for your inverter model.

- **High Battery** - In the event the battery voltage approaches the **HBCO** (High Battery Cut Out) level, the inverter will automatically shut down to prevent the inverter from supplying unregulated AC output voltage. The inverter's status LED turns off when a high battery fault condition occurs. The inverter will automatically restart when the battery falls to the **HBCI** (High Battery Cut In) level. Refer to Table 3-1 to determine the HBCO and HBCI levels for your inverter model.



Info: High battery voltage may be caused by excessive or unregulated voltage from the solar panels or other external charging sources.

- **Overload** - During inverter and standby operation, the inverter monitors the DC and AC current levels. In the event of a short-circuit or overload condition, the inverter will shut down. The inverter will need to be reset to start operating, refer to section 4.1 for information on resetting the inverter.

- **Over-temperature** - If internal power components begin to exceed their safe operating temperature level, the inverter will shut down to protect itself from damage. The inverter's status LED turns OFF to indicate the over-temperature fault condition. The inverter will automatically restart after the units cools down.

- **Internal Fault** - The inverter continually monitors several internal components and the processor communications. If an condition occurs that does not allow proper internal operation, the inverter will shutdown to protect itself and the connected loads. The inverter will need to be reset to start operating, refer to section 4.1 for information on resetting the inverter.

Table 3-1, Inverter Battery Turn On/Off Levels

Inverter battery turn on/off levels	MS-PAE Inverter/Chargers	
	24 VDC models	48 VDC models
HBCO	>33.8 VDC	>67.6 VDC
HBCI	33.2 VDC	66.4 VDC
LBCI	25.0 VDC	50.0 VDC
LBCO (1 minute delay)	20.0 VDC (18.0 - 24.4 VDC)*	40.0 VDC (36.0 - 48.8 VDC)*
LBCO (no delay)	17.0 VDC	34.0 VDC

* adjustable with remote control

3.5 Start-Up

ON/OFF Switch - The inverter can be turned on and off by lightly pressing and releasing the Power ON/OFF switch on the front of the inverter (refer to figure 3-5). When the inverter is first connected to the batteries, or when its automatic protection circuit has turned the inverter off, the ON/OFF switch will need to be pressed to start the unit (or reset per section 4.1). Once the inverter has been turned on, pressing the Power ON/OFF switch alternately turns the inverter on and off.



WARNING: The Power ON/OFF control switch does not turn on or off the charger feature. If AC power (Utility or generator) is connected and qualified on the AC input, this AC power will also be available on the AC output and is not controlled by the Power ON/OFF switch.

Status LED Indicator - The status indicator is a green LED (Light Emitting Diode) that provides information on the operational mode of the inverter. Watch this indicator (refer to figure 3-5) for at least 10 seconds to determine the inverter's operational condition from the information below:

- **Off** - Indicates the inverter is off; there is no AC power (inverter, utility or generator) at the inverter's output terminals. If the LED says off after pressing the ON/OFF switch, there is a "fault" condition such as low battery, high battery, overload, overtemperature or an internal fault. Refer to the Troubleshooting section to help diagnose/clear the fault condition.
- **Slow flash** (blinks on once every 8 seconds) - Indicates "float" charging; and the inverter is in Standby Mode (the external AC power that is connected to the inverters input is passing thru the inverter and is powering the AC loads connected to the inverter's output).
- **Medium flash** (blinks on once every second):

When AC power is not connected to inverter input - Indicates the inverter is on and using energy from the battery. The inverter is either: 1. Inverting - providing full power to the loads connected to the inverter; or 2. Searching - conserving power and waiting for a load to be turned on that meets or exceeds the Search Watts parameter (5 watts is the inverter default setting).

When AC power is connected to inverter input - Indicates "Absorb" charging; and the inverter is in Standby Mode (the external AC power that is connected to the inverters input is passing thru the inverter and is powering the AC loads connected to the inverter's output).

- **On (solid)** - Indicates "bulk" charging; and the inverter is in Standby Mode (the external AC power that is connected to the inverters input is passing thru the inverter and is powering the AC loads connected to the inverter's output).

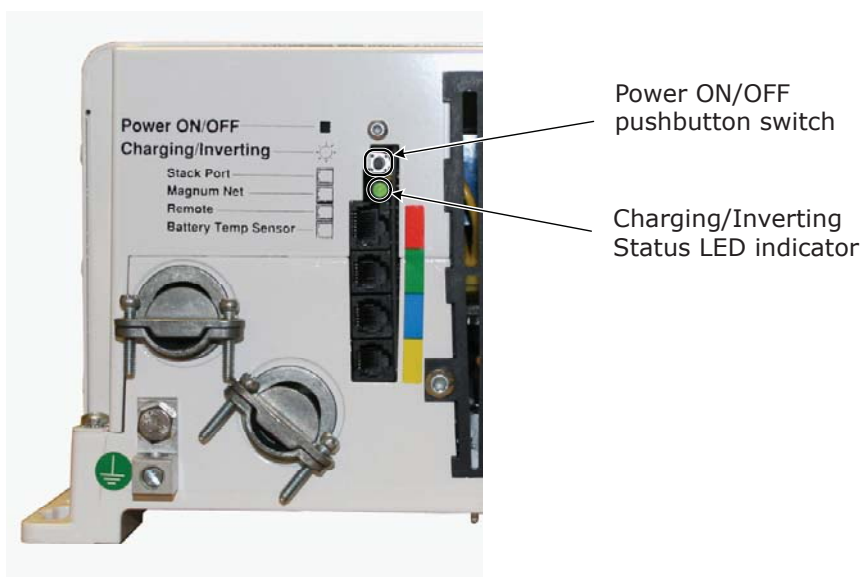

Figure 3-5, Power Switch and Status Indicator

3.6 Factory Default Values

Your MS-PAE Series inverter/charger uses default values for the adjustable settings (shown in Table 3-2) that are adequate for most installations. If some of your operating parameters need to be changed from the default values, the optional ME-RC remote control can be used to make those changes. To help you determine if you need the ME-RC remote display, information on the inverter/charger settings that can be changed is provided below. The settings once programmed are saved in the remote's nonvolatile memory and are preserved until changed - even if DC power to the inverter is lost (as long as the ME-RC remote is connected). For information on the full range of settings for each function, refer to the ME-RC Owner's Manual at www.magnumenergy.com.

- **Shore Max** - This setting ensures the inverter AC loads receive the maximum current available from the utility or generator power. When the total current used to power the AC loads and charge the batteries begins to approach the *Shore Max* setting, the current that was used for charging the batteries will automatically be reduced.
- **01 Search Watts**: This setting allows you to turn off the power-saving Search Mode circuitry or adjust the power level at which the inverter will "wake up" and start inverting.
- **02 LowBattCutOut**: This setting determines when the inverter will turn off based on low battery voltage. The inverter turns off automatically after the battery voltage has been below this setting for more than one minute. This protects the batteries from over-discharge and the AC loads from unregulated power (brown-outs).
- **03 Batt AmpHrs**: This setting allows the user to input the battery bank size in amp hours which tells the charger how long to charge the batteries in the Absorb charge stage.
- **04 Battery Type**: Sets the type of batteries being used in the system; this information tells the charger what voltage level to use to charge the batteries.
- **05 Charge Rate**: This setting can be used to turn off the charger, limit the amount of current that the charger can use (leaving more current available to power loads); or to ensure small battery banks are not overheated because of a charge rate that is too high.
- **06 VAC Dropout**: Sets the minimum AC voltage that must be present on the AC input before the unit transfers from Standby Mode to Inverter Mode. This protects the AC loads from utility outages and brown-outs. On MS-PAE models, when two inputs (leg 1 and leg 2) are used, the VAC Dropout voltage is determined by the sum of the two inputs $\div 2$. For example, if input 1 = 120VAC and input 2 = 110 VAC, the sum (230) $\div 2 = 115$. In this example, 115 VAC is what the inverter's AC input is sensing to determine when to stay connected or disconnect and start inverting.

Using the ME-RC remote also provides the following features:

- allows you to enable an equalize charge for certain battery types.
- displays inverter/charger's operating status
- provides fault information for troubleshooting

Table 3-2, Inverter/Charger Default Values

Adjustable Settings	Default Values
Shore Max	60A
01 Search Watts	5W (5 watts)
02 LowBattCutOut	20.0 VDC (24 VDC models), 40.0 VDC (48 VDC models)
03 Batt AmpHrs	600 AmpHrs (Absorb Time = 120 minutes)
04 Battery Type	Flooded - Liquid Lead Acid 24 VDC models (Bulk = 29.2 VDC, Float = 26.8 VDC) 48 VDC models (Bulk = 58.4 VDC, Float = 53.6 VDC)
05 Charge Rate	100%
06 VAC Dropout	80VAC

4.0 Troubleshooting

The MS-PAE Series inverter/charger is a fairly simple device to troubleshoot. There are only two active circuits (AC and DC) as well as a charging circuit. The following chart is designed to help you quickly pinpoint the most common inverter or charger failures.

Table 4-1, Troubleshooting Guide

Symptom	Possible Cause	Recommended Solution
No output power. Inverter LED is OFF.	Inverter is switched OFF.	Switch the inverter ON.
	Battery voltage is too low. The battery voltage level has dropped below the Low Battery Cut Out (LBCO) set-point for more than one minute.	Check fuses/circuit-breakers and cable connections. Check battery voltage at the inverter's terminals. Your batteries may need to be charged, this fault condition will automatically clear when the battery voltage exceeds the LBCI voltage.
	The battery voltage is too high. The inverter automatically resets and resumes operation when the battery voltage drops to the HBCI voltage or lower.	This condition usually occurs only when an additional charging source (alternator, solar panels or other external charging sources) is used to charge the battery bank. Reduce or turn off any other charger to the inverter batteries to allow the voltage level to drop.
	Over-temperature condition: The internal temperature of the inverter has risen above acceptable limits; caused by loads too great for the inverter to operate continuously, or by lack of ventilation to the inverter. When the unit has cooled, it will automatically reset and resume	Reduce the number of electrical loads that you are operating, this will avoid a repeat Overtemp shutdown if the cause was too many loads for the ambient conditions. Check ventilation around the inverter, ensure cool air is available to pass-thru the inverter (refer to the ventilation requirements in section 2.3).
	AC Overload condition: The inverter has turned off because the connected loads are larger than the inverters output capacity or the output wires are shorted.	Reduce the AC loads connected to the inverter or remove all AC output wiring and restart the inverter.
	Internal fault: This fault occurs when an internal fault is detected.	To clear this fault, an inverter reset is required. Remove DC power to the inverter or press and hold down the power switch on the inverter for 15 seconds (until the green Status LED comes on). If this fault does not clear, the unit will need to be serviced.
No output power. Green LED is flashing.	Unit is in "Search Mode", which means load is too small for search mode circuit detection.	Turn on load greater than 5 watts to bring inverter to full output power or turn off search with remote.
Low output or surge power. Green LED is flashing.	Loose or corroded battery cables. Low batteries. Loose AC output connections. Battery cables are the wrong length or gauge.	Clean and tighten all cables. Recharge or replace batteries. Tighten AC output connections. Verify recommended cable lengths and gauges from the manual. Replace cables as necessary.
Low charging rate when connected to shore power.	Charge rate set too low. Low AC voltage (< 90 VAC).	Adjust charge rate or Shore settings with remote. Check AC input wiring.
Low charging rate when using a generator.	Generator output is too low to power both load and charger.	Reduce the load, increase the generator's RPMs Check the SHORE settings (if remote connected).
Charger doesn't charge.	Loose or corroded battery cables. Defective batteries. Wrong charger settings. Wrong AC input voltage.	Clean and tighten battery cables. Replace batteries. Adjust the charger settings, ensure the unit is not in charger standby. Verify proper AC input voltage and frequency.
While charging, the DC charge voltage is higher or lower than expected.	If the Battery Temperature Sensor (BTS) is installed, the DC voltage will increase or decrease depending on the temperature around the BTS.	This is normal; see section 3.3 (Battery Temperature Sensor Operation) for more information.

Troubleshooting

4.1 Performing an Inverter Reset

Under some fault conditions (i.e. an 'internal' fault) the inverter will need to be reset.

To reset the inverter:

Press and hold the Power ON/OFF pushbutton (see figure 4-1) for approximately fifteen (15) seconds until the Charging/Inverting Status LED comes on and flashes rapidly; once the rapid flashing has begun, release the Power ON/OFF pushbutton. The Status LED will go off after the pushbutton is released.

After the inverter reset is completed, press the ON/OFF pushbutton to turn the inverter ON.



Info: The Power ON/OFF pushbutton is a small momentary type switch which operates by lightly pressing and releasing.

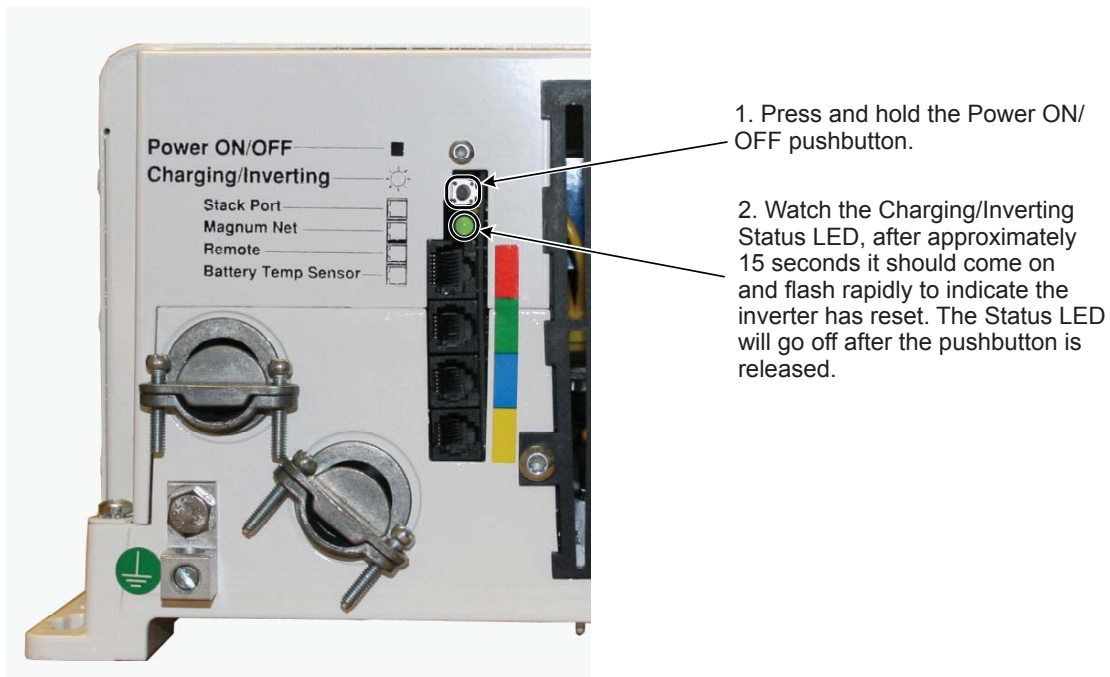

Figure 4-1, Performing an Inverter Reset

5.0 Parallel Operation

This section provides information about operating the MS-PAE Series inverters in parallel.



Info: The ME-RTR Owner's Manual provides more detailed installation information on Parallel stacking,



WARNING: The information in this section is meant to supplement the information in previous sections. To prevent personal injury or equipment damage, you must carefully read and follow all instructions and warnings in this Operator's Manual.

5.1 Overview

A single MS-PAE inverter produces 120/240VAC at its rated power (i.e. MS4024PAE provides 4000 watts of inverter power). Parallel stacking synchronizes multiple inverters to work together as a single inverter/charger system to increase the inverter continuous and surge capacity, increase the charging capability to the battery bank and increase the AC pass-through capacity.

The ME-RTR router allows the MS-PAE Series inverters to operate in phase by having one of the inverters operate as the Master and the others as Slaves, which are controlled by the master. When first turned on, all the stacked inverters are powered and begin to monitor the power required by the AC load. If the power requirement by the AC load decreases, the slave inverters power down into Power Standby mode until needed. The Power Standby feature allows the inverters to shut down to reduce power consumption and quickly begins inverting when the loads demand more power.

Because the paralleled inverters operate as a single unit, the total battery charging capability and AC pass-through capacity are also increased. This helps with the fuel consumption efficiency and available current to transfer to loads when using large generators. When the generator (or utility power) is connected to the parallel system, the Master inverter first synchronizes, then connects. Since the Slave inverter(s) follow the Master inverter, they are prevented from connecting until the Master inverter has synchronized and connected. After the full system has connected, battery charging begins. This allows a smooth transition from inverter mode to charger mode since the slave inverters are already synchronized when they transfer the loads and start battery charging.

5.2 Conditions for Parallel System

When connecting units in parallel, the following requirements must be met:

1. Only the MS-PAE Series inverters are capable of being stacked in parallel and models must be identical for parallel stacking.
2. A maximum of four identical MS-PAE inverters can be connected in parallel.
3. The ME-RTR router must be connected to communicate and synchronize with other MS-PAE inverters for parallel operation.
4. The Router Sync Cable from Magnum (PN: A80-8306) must be used to connect directly from the ME-RTR to each inverter. This cable is the only one that meets the parallel system size, data and insulation requirements and obtain NEC/CEC site approval.
5. The inverters must be connected to the same battery bank.
6. The DC connection cables from the battery to the inverter must be of equal length and size.
7. The inverter's negative terminals of the inverters must be connected together either at the inverters or at a location close to the inverters (within 18 inches / 0.5 meters).
8. The AC input cables to each inverter as well as the AC output cables from each inverter must be of equal length and size (length to AC input may be different from length to AC output).
9. Place the MS-PAE inverters close to each other, but allow at least 3" for ventilation purposes under, above and in front of the inverter.
10. The AC input to every inverter must be from the same AC source and the two 120VAC legs from that AC source into each inverter input must be 180° out-of-phase from each other.
11. Each inverter must have appropriate AC and DC overcurrent protection.



Info: The MP Series enclosures meet the requirements needed to parallel stack the MS-PAE inverters and are UL listed and CSA certified for a code compliant installation.

Parallel Operation

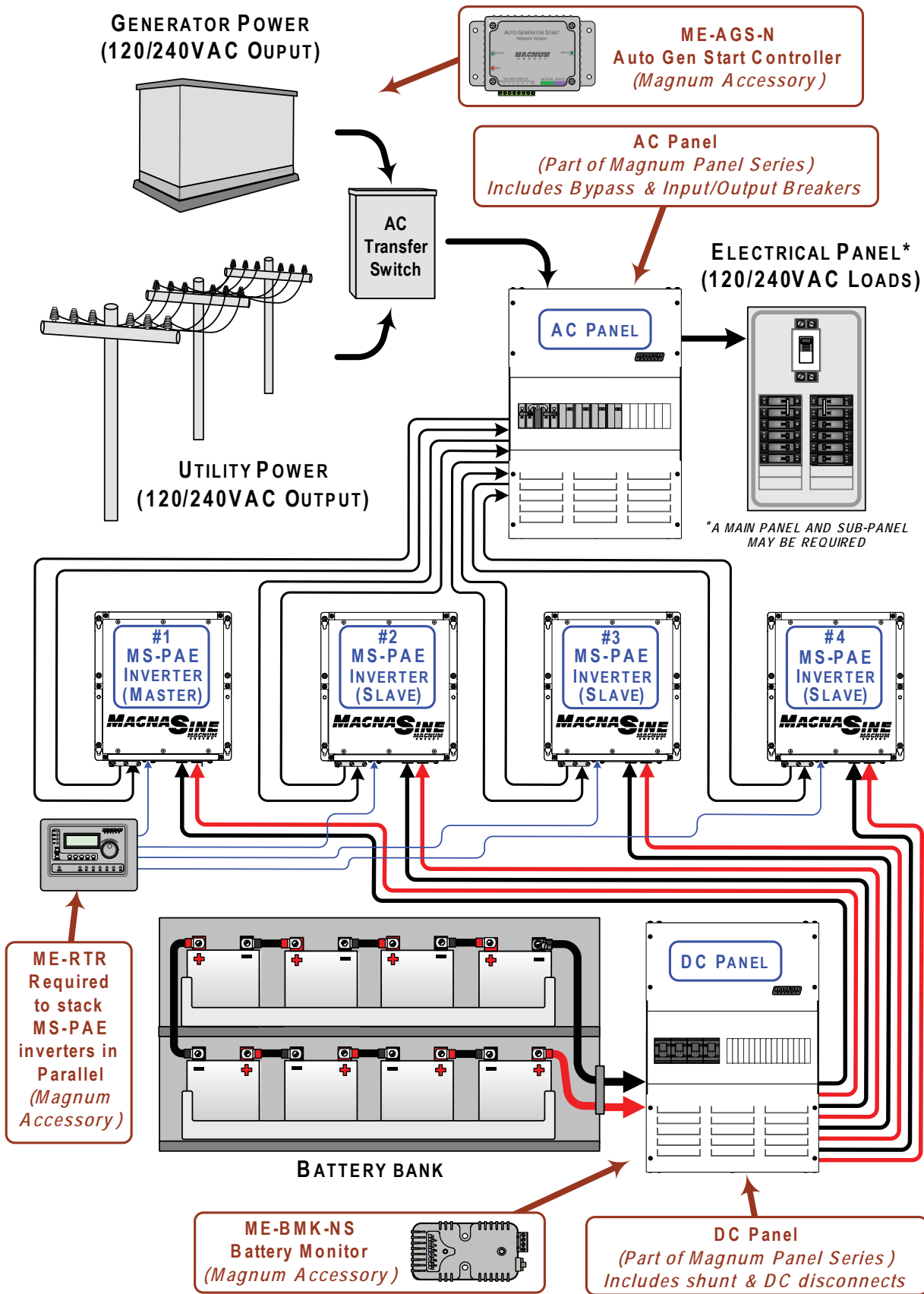

Figure 5-1, Simplified Installation Diagram - Multiple Inverters (stacked in parallel)

5.3 Parallel System Connections and Components

The basic installation procedure of the parallel system is similar to that of single inverter system. However, the AC and DC connections and components required in the parallel system must be considered.

5.3.1 AC and DC connections simplified using Magnum Panels

The AC and DC connections in the parallel system depend upon other components (noted in the two section below in **bold**), but are simplified when using the Magnum Panel (MP) Series of enclosures. As shown in Figure 5-1, the AC Panel and DC Panel - which are part of the MP Series enclosures - provide these separate components; and the specific AC or DC wiring to these components are completed for you. Figures 5-2 and 5-3 are simplified diagrams of the AC and DC Panels showing the connections and components.

5.3.2 AC Connections Required in Parallel System

The AC input supply to the parallel system must be a 120/240 VAC split-phase system that provides two line conductors (referred to as L1 and L2), a neutral, and ground. Each MS-PAE inverter requires a double-pole circuit breaker rated for a maximum 30A each pole. Typically the AC supply originates in a main distribution panel, providing the separate **AC Breakers** required for the AC input of each MS-PAE inverter. This main panel also has to provide the **AC Buss-Bars** to allow connection of the neutral and ground conductors to each inverter input.

The AC output side of the parallel system requires an electrical panel, referred to as the inverter panel, that combines all the inverter outputs and be equipped with a large double-pole circuit breaker rated for the total output current of the parallel system. This inverter panel must provide the **AC Buss-Bars** for the neutral and ground conductors from each inverter output.

If the inverter system requires isolation from the AC source for servicing without losing power to the AC loads, an **AC Bypass** should be installed between the AC input and output connections.

5.3.3 DC Connections Required in Parallel System

When inverters are stacked they must operate from a common battery bank. In other words, the DC negative of one inverter must be common with the second inverter and likewise for the DC positive. Each inverter must be wired to the single battery bank separately and have a **DC Breaker** in the positive side, matched to the cable size.

All DC negatives are required to be combined on a **DC Buss-Bar** and if the system requires battery bank monitoring, a full system **DC Shunt** will need to be installed in the DC negative side.

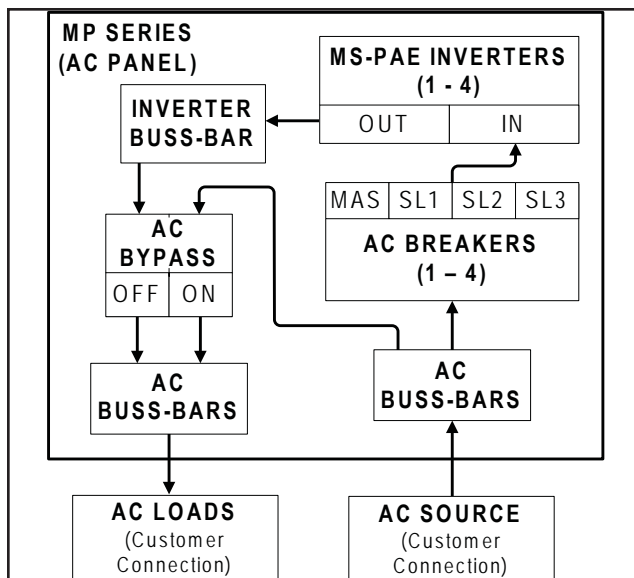

Figure 5-2, Simplified Magnum Panel (AC Panel)

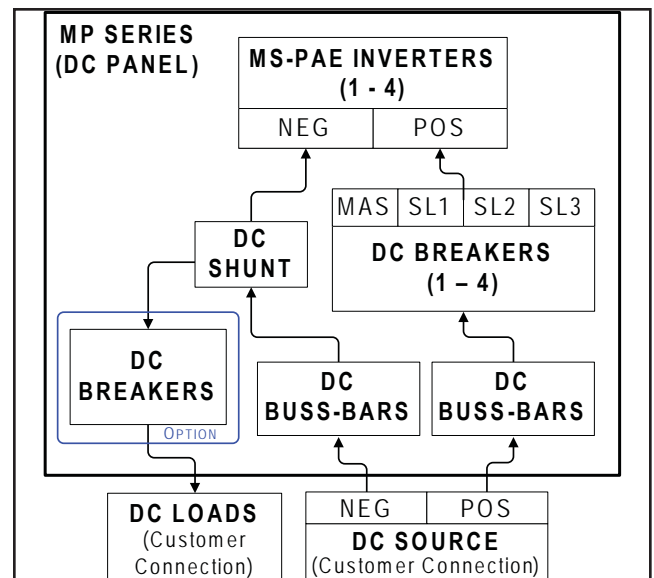

Figure 5-3, Simplified Magnum Panel (DC Panel)

Appendix A - Specifications

A.1 Specifications

Table A-1, MS-PAE Specifications

Models	MS4024PAE	MS4448PAE	MS3748PAEJ
Inverter Specifications			
Input battery voltage range	18.0 to 33.8 VDC	36.0 to 67.6 VDC	36.0 to 67.6 VDC
Absolute maximum DC input	50 VDC	68 VDC	68 VDC
Nominal AC output voltage	120 / 240 VAC split phase		
AC output voltage accuracy	L-N: 120 VAC ±5%, L-L: 240 VAC ±5% (continuous power)		
Output frequency and accuracy	60 Hz ± 0.04%		50 Hz ± 0.4Hz
Total Harmonic Distortion (THD)	< 5%		
Continuous power output (at 25° C with 12.5 VDC nominal)	4000 VA (L-L) (max 81% output imbalance from L-N)	4400 VA (L-L) (max 81% output imbalance from L-N)	3700 VA (L-L) (max 81% output imbalance from L-N)
Continuous AC output current	L-N: 27.0A/120VAC, L-L: 16.7A/240VAC	L-N: 29.7A/120VAC, L-L: 18.3A/240VAC	L-N: 25.0A/120VAC, L-L: 15.5A/240VAC
1 msec surge current (amps AC)	L-N: 120, L-L 70	L-N: 120, L-L 70	L-N: 120, L-L 70
100 msec surge current (amps AC)	L-N: 72, L-L 40	L-N: 75, L-L 40	L-N: 75, L-L 32
5 sec surge power (real watts)	5800	8500	6200
30 sec surge power (real watts)	5200	6000	6000
5 min surge power (real watts)	4800	5400	3600
30 min surge power (real watts)	4500	4800	3500
Maximum continuous input current	267 ADC	147 ADC	123 ADC
Inverter efficiency (peak)	93%	94%	91%
HBCO / HBCI (High Battery Cut Out / In)	>33.8 VDC / 33.2 VDC	>67.6 VDC / 66.4 VDC	>67.6 VDC / 66.4 VDC
LBCO / LBCI (Low Battery Cut Out / In)	18.0 VDC (adjustable) / 25.0 VDC	36.0 VDC (adjustable) / 50.0 VDC	36.0 VDC (adjustable) / 50.0 VDC
AC Relay Transfer time (minimum)	16 msec		
Power Consumption - searching	< 6 watts		< 10 watts
Power Consumption - inverting (no load)	27 watts	25 watts	22 watts
Output Waveform	Pure Sine Wave		
Charger Specifications			
Continuous charger output at 25° C	105 ADC (@28.2VDC)	60 ADC (@56.4VDC)	55 ADC (@56.4VDC)
Input current for continuous rated output	15 AAC (at 120 VAC) per leg	17.5 AAC (at 120VAC) per leg	8 AAC (at 120VAC) per leg
Charger efficiency (peak)	90%		
AC input frequency range	50 to 70 Hz		40 to 60 Hz
AC input voltage range	L-N: 60 to 140 VAC (120 VAC nominal) L-L: 120 to 280 VAC (240 VAC nominal)		
Power factor	>0.95		
General Features and Capabilities			
Transfer relay capability	2 legs at 30 AAC maximum per leg		
Five stage charging capability	Bulk, Absorb, Float, Equalize (requires remote) and Battery Saver™		
Battery temperature compensation	Standard with included temp sensor (battery temp 0 to 50° C)		
Internal cooling	0 to 120 cfm variable speed drive using dual 92mm brushless DC fans		
Over-current protection	with two overlapping circuits		
Over-temperature protection	on transformer, MOSFETs, and ambient temperature		
Corrosion protection	PCB's conformal coated, powder coated chassis/top, and stainless steel fasteners		
Safety Listings	ETL listed to ANSI / UL STD 1741 and CSA STD C22.2 No. 107.1-01		NA
Warranty	2 years parts and labor		
Environmental Specifications			
Operating temperature	-20° C to +60° C (-4° F to 140° F)		
Nonoperating temperature	-40° C to +70° C (-40° F to 158° F)		
Operating humidity	0 to 95% RH non-condensing		
Physical Specifications			
Unit Dimensions (h x w x d)	13.75" x 12.65" x 8.0" (34.9 cm x 32.1 cm x 20.3 cm)		
Shipping Dimensions (h x w x d)	18.5" x 17.5" x 12.5" (47 cm x 44.5 cm x 31.8 cm)		
Mounting	Shelf or wall (vents not allowed to face downward unless ME-HOOD and ME-CB are installed)		
Unit Weight	55 lbs (24.9 kg)		
Shipping Weight	60 lbs (27.2 kg)		
Max operating altitude	15,000' (4570 m)		

Specifications subject to change without notice

A.2 Efficiency Graphs

The following curves are plotted to show the MS-PAE series efficiency over the inverter's power range and is displayed as a percentage.

These graphs represent a typical inverter's efficiency while operating resistive loads. Motors and other inductive loads run less efficiently due to the impact of power factor losses.

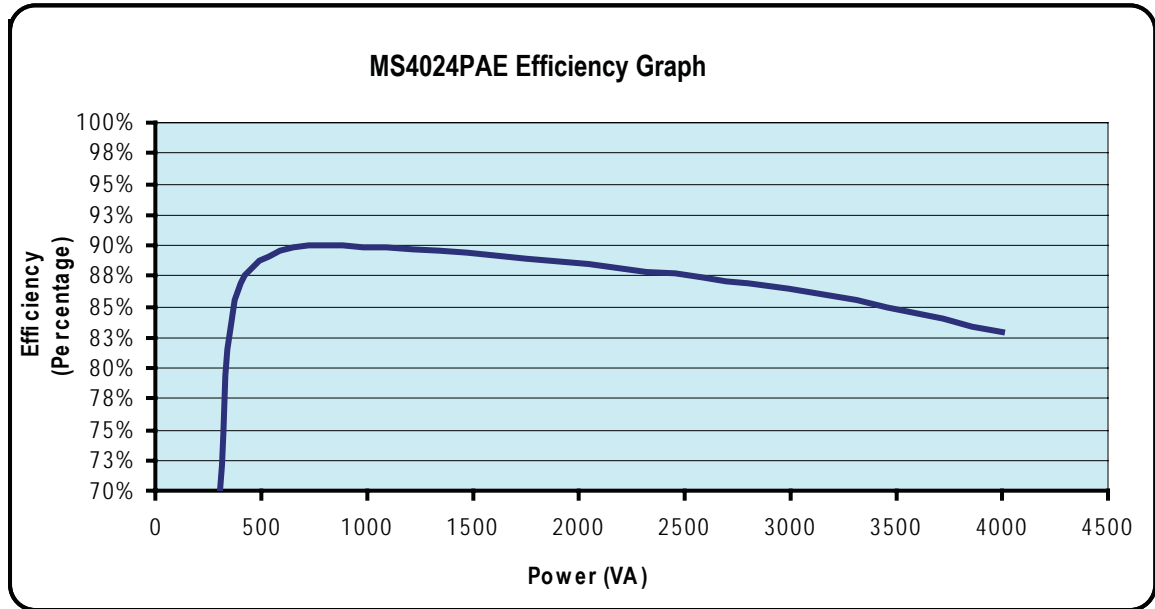

Figure A-1, MS4024PAE Efficiency Chart

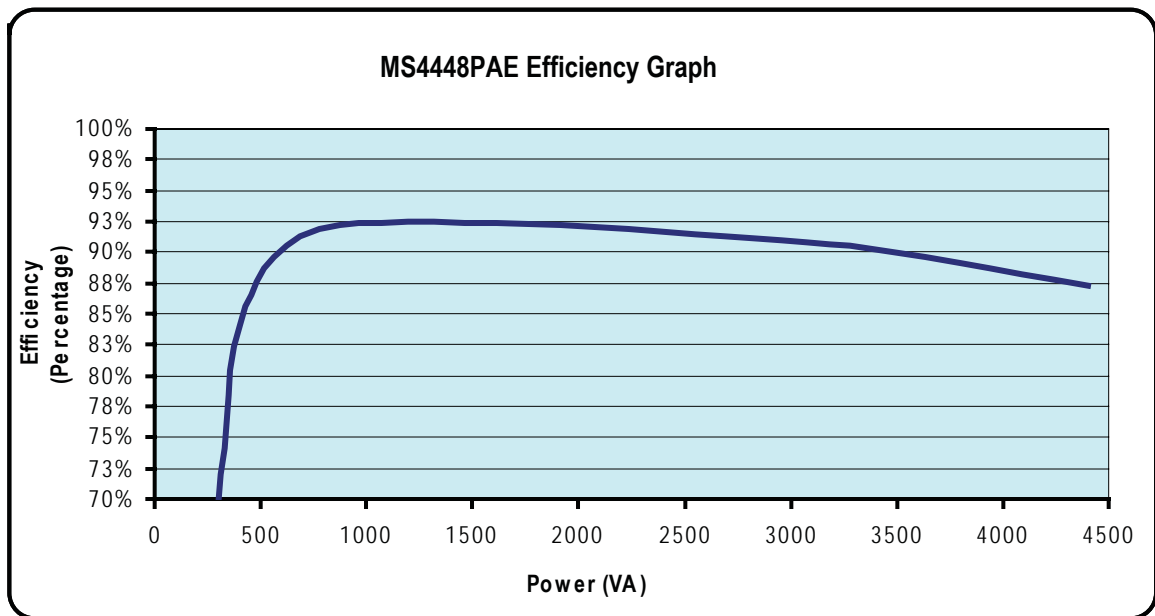

Figure A-2, MS4448PAE Efficiency Chart

Appendix B - Optional Equipment/Accessories

B.1 Optional Equipment/Accessories

The following Magnum Energy components are available for use with the MS-PAE Series inverter/Charger. Some of these items are required depending upon the intended use of the inverter.

MMP Series Enclosures

The MMP175-30D, MMP175-60S, MMP250-30D and MMP250-60S enclosures are for single inverter applications. The MMP Series enclosures have been specifically designed to combine all of the major components required for a renewable energy system - inverter/battery disconnect, AC overcurrent protection, grounding connections and a full system inverter bypass switch as a convenient way to isolate the inverter for battery maintenance - into a single, easy to install pre-wired enclosure.

MP Series Enclosures

The MP SL, MP SH, MP DH enclosures have been specifically designed to combine the MS-PAE inverter's when configured for parallel operation. The MP enclosures feature convenient front mounted AC and DC connections and easy panel operation using the optional ME-RTR router. Choose the MP model based on your power capacity needs. Each model is expandable, start with the base model and just one inverter and in the future add another inverter - up to four inverter's total depending on your model - with ease, using the MPX expansion boxes.

Router Control Display Panel

The ME-RTR Router Control Display Panel provides operating information and setup/troubleshooting capabilities for multiple Magnum inverters. Allows up to four MS-PAE inverter's to be connected in a parallel configuration for increased inverter power.

Advanced Remote Control Display

The ME-ARC allows the advanced features of the MS-PAE inverter to be configured. This LCD remote display also provides advanced monitoring/troubleshooting and includes a FAVS button to access your favorite features quickly.

Standard Remote Control Display

The ME-RC Remote Control is simple to use; an easy-to-read LCD screen and "at a glance" LEDs display complete inverter/charger status. Soft keys provide simple access to menus and a rotary encoder knob allows you to scroll through and select a wide range of settings such as Inverter ON/OFF, Charger ON/OFF, Shore Power Breaker Setting, AGS Control, Meter Button, Setup and Tech menus.

Auto Generator Controller

The ME-AGS-N (Rev 5.0) is designed to automatically start your generator based on low battery condition or high temperature. The AGS controller includes an input voltage jumper (for 12, 24 and 48 volt battery banks) and a 4-position DIP (Dual In-line Package) switch which provides the ability to change the relay timing configurations to allow compatibility with a wider range of generators. Adjustable settings include starting the generator based on battery voltage, Time of day, battery State of Charge or High Temperature. Includes "Quiet Time" with an easy to set clock. AGS settings do not interfere with the manual start / stop operation of the generator.

Battery Monitor

The Battery Monitor Kit (ME-BMK) is a single battery bank amp-hour meter that monitors the condition of the battery and provides information to let you know how much energy you have available and let you plan your electrical usage to ensure the battery is not being over-discharged.

Fuse Block/Fuses

The Magnum Fuse/Fuse-blocks (TFB-XXX) are used to protect the battery bank, inverter, and cables from damage caused by DC short circuits and overloads. They include a slow-blow, high current Class-T fuse with mounting block and protective cover. The fuse sizes are available in 125, 200, 300 and 400 amps.

C.1 General Battery Information

C.1.1 Battery Location

Periodic maintenance (i.e. checking connections, cleaning, watering) on batteries is required. Locate the batteries in an accessible location to perform this maintenance. Two feet clearance above the batteries is recommended for access to the battery terminals and removable caps (lead acid battery types). The battery bank should be located as close to the inverter as possible without limiting access to the inverter’s disconnects.

C.1.2 Battery Types

Batteries are available in different sizes, amp-hour ratings, voltage and chemistries. They are also available for starting applications (such as an automobile starting battery) and deep discharge applications. Only the deep cycle types are recommended for inverter applications; using a starting battery in an inverter (deep cycle) application will greatly shorten their useful life. Choose the batteries best suited for the inverter installation and cost. Use only the same battery type for all batteries in the bank. For best performance, all batteries should be from the same lot and date. This information is usually printed on a label located on the battery.

C.1.3 Battery Temperature

Battery performance of lead-acid type batteries is greatly affected by extreme temperatures. When a lead-acid type battery is cold, its effective amp-hour capacity is reduced. When determining the battery requirements needed for the inverter system, realize that the battery capacity will be reduced if they will be installed in a climate where extremely cold temperatures are expected. In this type of environment, the batteries should be located in a heated area. At the minimum, the batteries should be installed in an insulated enclosure; which will keep the batteries warmer as they are being charged.

The battery bank should also be protected from high temperatures, which will shorten battery life. In high heat situations the battery room/enclosure should be ventilated to bring in cooler air and exhaust the hotter air. The performance of the battery bank/inverter system will substantially increase by monitoring and preventing extreme temperatures around the batteries.

C.1.4 Battery Bank Sizing

The size of the battery bank determines how long the inverter will power the AC loads without recharging. The larger the battery bank, the longer the run time. Size your battery bank to the systems AC load requirements and length of time required to run from the batteries. In general, the battery bank should not be discharged more than 50%. Additional DC charging devices such as solar, wind, hydro, etc. can provide longer run times by recharging the batteries in the absence of AC utility or generator power.



Info: For the MS-PAE Series inverter/charger to perform optimally, a minimum battery bank of 200 AH is recommended for moderate loads (<1000W) and greater than 400 AH for heavy loads (≥1000W).

Table C-1, Typical Appliance Power Consumption

Device (AC Load)	Wattage Rating	Device (AC Load)	Wattage Rating
Blender	400 W	Coffee Maker	1200W
Computer	300 W	Color TV (19")	150 W
Drill	500 W	Hair Dryer	1000W
Hot Plate	1800 W	Iron	1000 W
Light (flo)	10 W	Light (inc)	100 W
Microwave	1000 W	Refrigerator*	500 W

*Refrigerators, freezers and water pumps typically only run about 1/3 of the time. When adding to the battery sizing worksheet, only list 1/3 of the total wattage rating of the appliance.

Appendix C - Battery Information

C.2 Battery Bank Sizing Worksheet

Complete the steps below to determine the battery bank size required to power your AC loads:

1. Determine the daily power needed for each load

- List all AC loads required to run; and
- List the Watt-Hours for each load (see table B-1 for common loads/wattage); and
- multiply by how many hours per day (or a fraction of an hour) each load will be used; and
- multiply by how many days per week you will use the listed loads; and
- divide by seven = **Average Daily Watt-Hours Per Load.**

Average Daily Watt-Hours Per Load				
AC load	watt-hours	(x) hours per day	(x) days per week	(÷7) = total power

2. Determine the total power needed each day for all the loads.

- Add the *Average Daily Watt-Hours Per Load* together = **Total Daily Watt-Hours.**

Total Daily Watt-Hours

3. Determine the battery Amp-Hour capacity needed to run all the loads before recharging.

- Divide the *Total Daily Watt-Hours* by the nominal battery voltage of the inverter (i.e. 12, 24 or 48 volts); and
- Multiply this by how many days the loads will need to run without having power to recharge the batteries (typically 3 to 5 days of storage) = **Storage Amp-Hours.**

(inverter battery voltage)

÷ _____ =

(days of storage)

x _____ =

4. Determine how deeply you want to discharge your batteries.

- Divide the *Storage Amp-Hours* by 0.2 or 0.5 to get the **Total Amp-Hours:**
 - 0.2 = Discharges the batteries by 20% (80% remaining), this is considered the optimal level for long battery life; or
 - 0.5 = Discharges the batteries by 50% (50% remaining), this is considered a realistic trade-off between battery cost and battery life.

Total Amp-Hours

Additional compensation:

Low battery temperature: If the batteries are installed in a location that will be exposed to low temperatures, the output current will be less. In these instances, you will need to determine the lowest temperature the battery bank will experience and multiply the *Total Amp-Hours* by the Multiplier below.

Temperature	80F/27C	70F/21C	60F/15C	50F/10C	40F/4C	30F/-1C	20F/-7C
Multiplier	1.00	1.04	1.11	1.19	1.30	1.40	1.59

Inverter efficiency: When the inverter is used in a back-up power application the inverter efficiency will not be a large concern; however if the inverter is the primary AC source for the calculated load, the *Total Amp-Hours* should be multiplied by 1.2 to factor in an average 80% inverter efficiency.

C.3 Battery Wiring

The battery bank must be wired to match the inverter's DC input voltage. In addition, the batteries can be wired to provide additional run time. The various wiring configurations are:

C.3.1 Series Wiring

Wiring batteries in series increases the battery bank's output voltage. A series connection combines each battery in a string until the total voltage matches the inverter's DC requirement. Even though there are multiple batteries, the capacity remains the same. In figure B-1 below, two 6 VDC/200 AH batteries are combined into a single string resulting in a 12 VDC, 200 AHr bank.

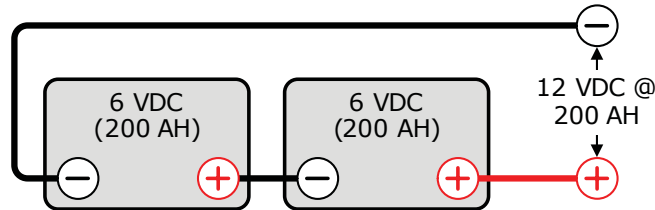

Series Battery Wiring
combines battery voltage:

$$\begin{array}{r} 200 \text{ AH @ } 6 \text{ VDC} \\ + \\ 200 \text{ AH @ } 6 \text{ VDC} \\ = \\ 200 \text{ AH @ } 12 \text{ VDC} \end{array}$$

Figure C-1, Series Battery Wiring

C.3.2 Parallel Wiring

Wiring batteries in parallel increases the battery bank's amp-hour capacity, which allows the AC loads to operate for a longer time. A parallel connection combines the number of batteries in the string to increase overall battery capacity; however, the voltage remains the same. In figure B-2 below, two 12 VDC/100 AH batteries are combined into a single 12 VDC, 200 AH battery bank.

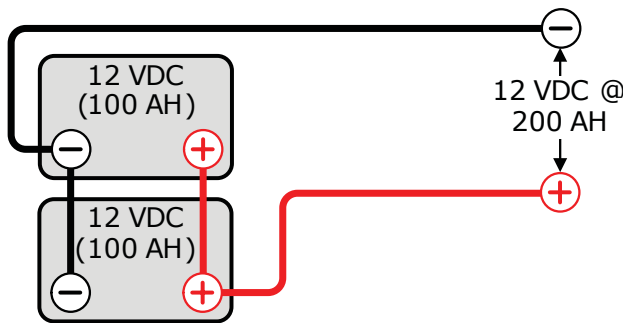

Parallel Battery Wiring
combines battery capacity:

$$\begin{array}{r} 100 \text{ AH @ } 12 \text{ VDC} \\ + \\ 100 \text{ AH @ } 12 \text{ VDC} \\ = \\ 200 \text{ AH @ } 12 \text{ VDC} \end{array}$$

Figure C-2, Parallel Battery Wiring

C.3.3 Series-Parallel Wiring

A series/parallel configuration increases both voltage (to match the inverter's DC requirements) and Amp-Hour capacity (to increase run-time for operating the loads) using smaller, lower-voltage batteries. In figure B-3 below, four 6 VDC/200 AH batteries are combined into two strings resulting in a 12 VDC, 400 AH battery bank.

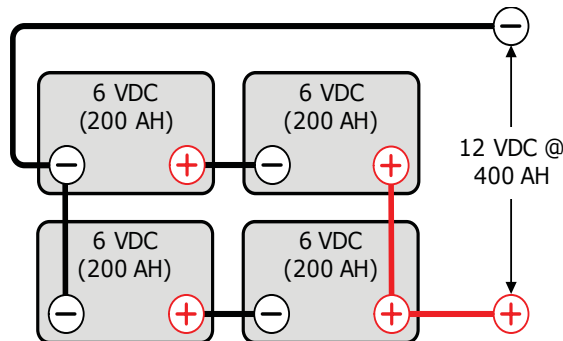

Series/Parallel Battery Wiring

combines battery voltage and capacity:

$$\begin{array}{r} 200 \text{ AH @ } 6 \text{ VDC} \\ + \\ 200 \text{ AH @ } 6 \text{ VDC} \\ \hline 200 \text{ AH @ } 12 \text{ VDC} \\ \text{add voltage in series} \end{array} \quad + \quad \begin{array}{r} 200 \text{ AH @ } 12 \text{ VDC} \\ + \\ 200 \text{ AH @ } 12 \text{ VDC} \\ \hline 400 \text{ AH @ } 12 \text{ VDC} \\ \text{add capacity in parallel} \end{array} = 400 \text{ AH @ } 12 \text{ VDC}$$

add voltage and capacity together

Figure C-3, Series-Parallel Battery Wiring

Appendix C - Battery Information

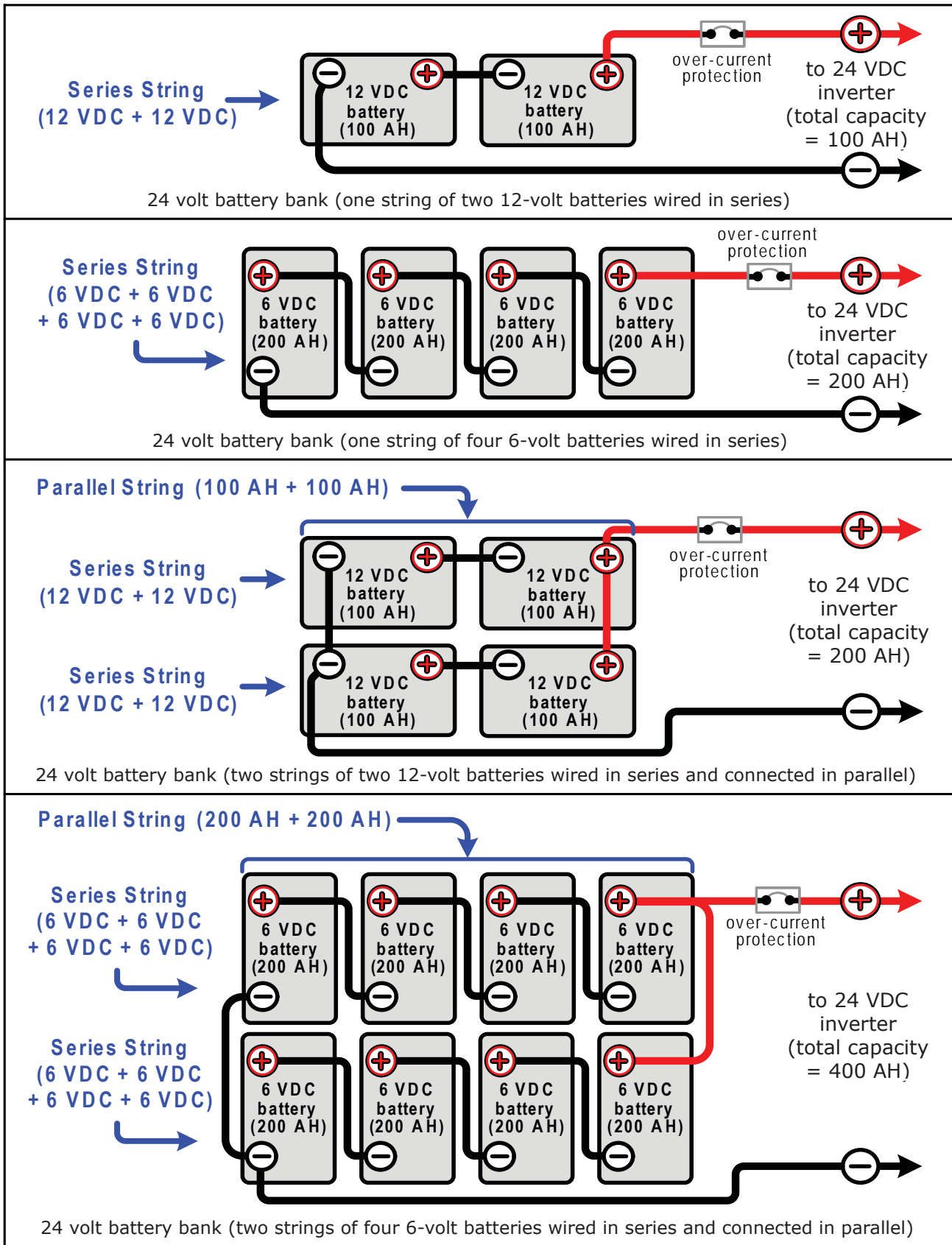

Figure C-4, Battery Bank Wiring Examples (24-volt)

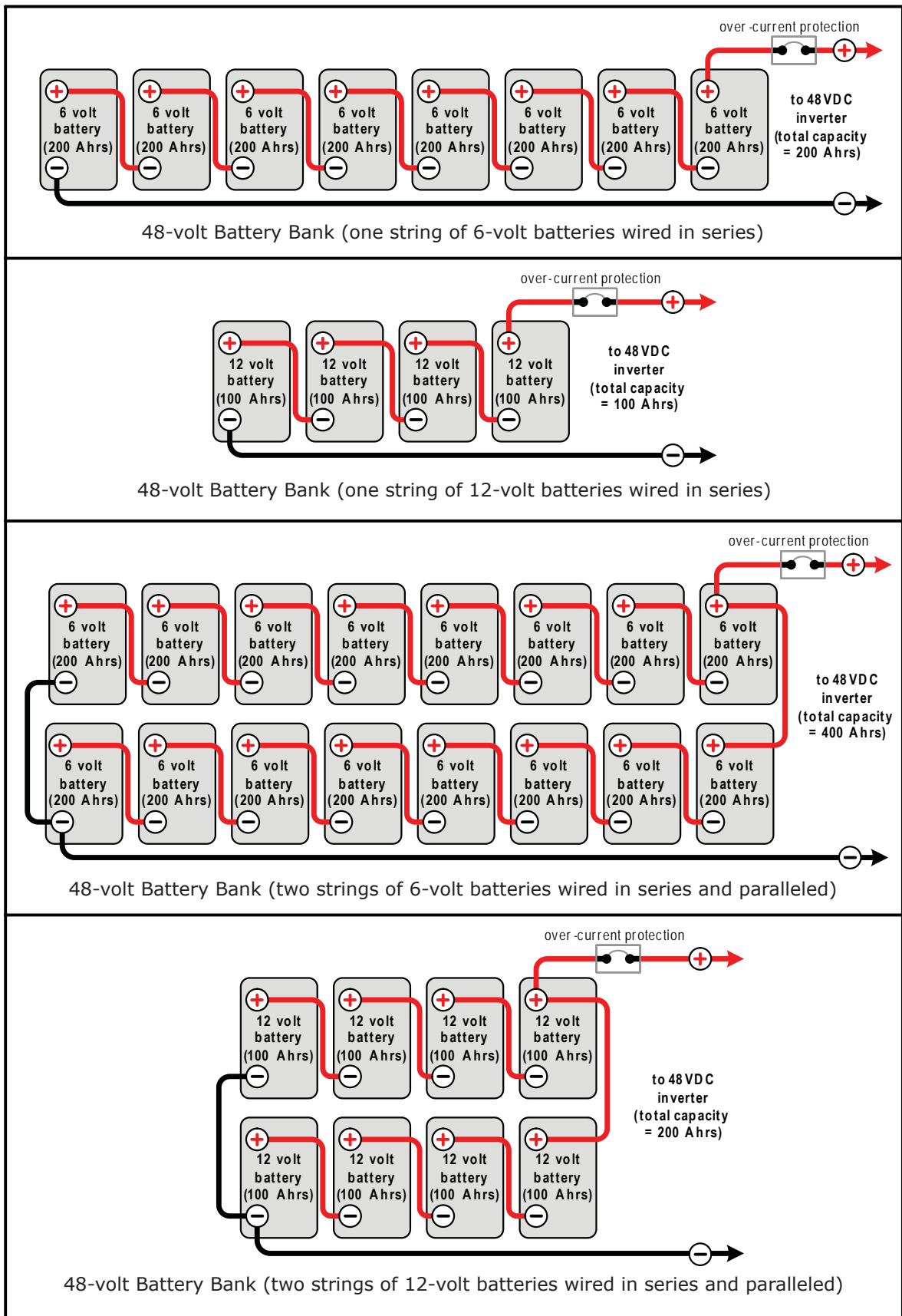

Figure C-5, Battery Bank Wiring Examples (48-volt)

Appendix D - Warranty and Service

D Warranty and Service

D.1 Limited Warranty

Magnum Energy, Inc., warrants the MS-PAE Series Inverter/Charger to be free from defects in material and workmanship that result in product failure during normal usage, according to the following terms and conditions:

1. The limited warranty for the product extends for 24 months beginning from the product's original date of purchase.
2. The limited warranty extends to the original purchaser of the product and is not assignable or transferable to any subsequent purchaser.
3. During the limited warranty period, Magnum Energy will repair, or replace at Magnum Energy's option, any defective parts, or any parts that will not properly operate for their intended use with factory new or rebuilt replacement items if such repair or replacement is needed because of product malfunction or failure during normal usage. The limited warranty does not cover defects in appearance, cosmetic, decorative or structural parts or any non-operative parts. Magnum Energy's limit of liability under the limited warranty shall be the actual cash value of the product at the time the original purchaser returns the product for repair, determined by the price paid by the original purchaser. Magnum Energy shall not be liable for any other losses or damages.
4. Upon request from Magnum Energy, the original purchaser must prove the product's original date of purchase by a dated bill of sale, itemized receipt.
5. The original purchaser shall return the product prepaid to Magnum Energy in Everett, WA. After the completion of service under this limited warranty, Magnum Energy will return the product prepaid to the original purchaser via a Magnum-selected non-expedited surface freight within the contiguous United States and Canada; this excludes Alaska and Hawaii.
6. This limited warranty is voided if:
 - the product has been modified without authorization.
 - the serial number has been altered or removed.
 - the product has been damaged from abuse, neglect, accident, high voltage or corrosion.
 - the product was not installed and operated according to the owner's manual.

D.2 How to Receive Repair Service

If your product requires warranty service or repair, contact either:

1. An Authorized Service Center listed on the Magnum Energy website at www.magnumenergy.com/servicecenters.htm; or
2. Magnum Energy, Inc. at:

Telephone: 425-353-8833
Fax: 425-353-8390
Email: warranty@magnumenergy.com

If returning the product directly to Magnum Energy for repair, you must:

- Return the unit in the original, or equivalent, shipping container.
- Receive a Return Materials Authorization (RMA) number from the factory prior to the return of the product to Magnum Energy for repair.
- Place RMA numbers clearly on the shipping container or on the packing slip.

**BEFORE RETURNING ANY UNIT TO MAGNUM ENERGY INC.,
A RETURN MATERIAL AUTHORIZATION (RMA) NUMBER IS REQUIRED.**



Magnum Energy, Inc.
2211 West Casino Rd.
Everett, WA 98204
Phone: 425-353-8833
Fax: 425-353-8390
Web: www.magnumenergy.com