

SnapNrack™
Solar Mounting Solutions

 **LISTED**
PV Mounting System
2703



SERIES 200 UL GROUND MOUNT SYSTEM

SnapNrack Solar Mounting Solutions
Code Compliant Installation Manual

Series 200 UL Introduction

SnapNrack Series 200 Ground Mount System offers a low profile, visually appealing, photovoltaic (PV) module installation system. This innovative system simplifies the process of installing solar PV modules, shortens installation times, and lowers installation costs.

SnapNrack systems, when installed in accordance with this manual, will be structurally adequate for the specific installation site and will meet the local and International Building Code.

The SnapNrack installation system is a set of engineered components that can be assembled into a wide variety of PV mounting structures. It is designed to be installed by qualified solar installation technicians. With SnapNrack you will be able to solve virtually any PV module mounting challenge.

Table of Contents

Step 1: Prepare for the Install	
SnapNrack Series 200 UL Ground Mount Parts	3
Survey the Site	3
Series 200 Configuration Tool	4
Project Information Sections	4
How to Configure Your System from the Engineering Letter	4
Layout Your System	5
Step 2: Excavation and Pipe Installation	
Concrete Pier	6
Grade Beam.	8
Step 3: Bracing Options	
Standard Bracing	10
Braced Option.	12
Step 4: Rail Installation	
Installing & Leveling Rails	14
Step 5: Module Installation	
Attaching Modules	16
Step 6: System Ground	
Installing SnapNrack Bonding Lug	18
Installing IIsco Bonding Lug	18

SnapNrack Series 200 UL Parts



SnapNrack Ground Rail

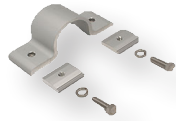

SnapNrack Pipe Clamp Assembly



SnapNrack Adjustable X-End Clamp Assembly



SnapNrack Universal End Clamp



SnapNrack Ground Rail End Cap



SnapNrack Mid Clamp



Kee Klamp Plug End



Hollaender Single Socket Tee



Hollaender Single Adjustable Socket Tee

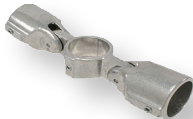

Hollaender Double Adjustable Socket Tee



Hollaender Plug End

Survey the Site

- Measure the installation area and develop an accurate drawing identifying any obstacles such as buildings, ditches and trees. (If plans are available, check to make sure that the plans match the layout.)
- Review the shading pattern across the installation area from nearby structures, trees, etc. A shade analysis prior to the design as a part of the standard site analysis is recommended.
- Determine the design wind speed and specific conditions for the site and reference the Configuration Table in the Engineering Letter for your state to determine the maximum allowable rail span and footing spacing for this site. (All engineering letters are available for download from www.SnapNrack.com.)

Series 200 UL Ground Mounted System

Installer Responsibility

- Make sure that the SnapNrack components and other products are appropriate for the particular installation and the installation environment.

- Use only SnapNrack supplied parts for the rail system.

- Ensure safe installation of all electrical aspects of the PV array.

Safety Guidance

- Always wear the proper OSHA approved safety equipment.

- Safety equipment should be checked annually for wear and quality.

- Always wear proper eye protection.

Design Tools

- SnapNrack has a suite of design tools to help configure your PV installation to be an accurate and fast install. Please visit us at: www.SnapNrack.com

Notes

- The UL Listing covers bonding for a load rating up to 45 psf

- These systems have been evaluated by UL for module to system bonding only, to the requirements of UL Subject 2703.

- Series 200 is UL Listed for the following modules: REC Solar AS (E308147): REC214, REC215, REC220, REC225, REC230, REC235, REC240, REC245, REC250, REC255, REC260, REC265, REC270, all followed by PE, PE(BLK), PE-US, PE-US(BLK), PE Q2 or PEQ3

- Before you dig any holes, contact all utilities in the area to locate any underground lines, pipes, and wiring.

- If you are unsure about the local design wind speed, consult with the local building jurisdiction.

Series 200 Configuration Tool configure.SnapNrack.com

Once you have calculated the specs for your system, you can enter the data into SnapNrack's online Configuration Tool for Series 200 Ground Mount System. The Configuration Tool creates a Bill of Materials specific to your system which can be exported as a separate file for you to use when contacting your local SnapNrack distributor.

Project Information Section

Array Tilt Angle _____

Wind Speed _____

Snow Load _____

Topo. Cond. _____

Grade Slope _____

Bracing Option _____

Module Brand _____

Module Model _____

Orientation _____

How to Configure Your System from the Engineering Letter

First calculate the East to West post spacing spans and foundation pier count. There is a SnapNrack span calculation table in the Engineering Letter for your state (All Engineering Letters for each state are available for download at www.SnapNrack.com/structural-engineering). Determine the site conditions: array tilt, the wind speed, and snow load. Find appropriate railspan, from the Engineering Tables.

Span Table Example

Standard Installation

Tilt Angle	Standard Installation						
	Max (PS)		12" Dia Pier		Required Braces		
Horizontal pipe spans	Sch 40	Sch 80	Short	Tall	A	C	D
0 = 0	10	11	3	3	Yes	Every 3rd Bay	No
0 > 0 < 7.5	8	9	3	3	Yes	Every 3rd Bay	No
7.5 > 0 < 15	8	9	3	3	Yes	Every 3rd Bay	No
15 > 0 < 22.5	7	8	3	4	Yes	Every 3rd Bay	Every 3rd Bay
22.5 > 0 < 30	6	7	3	4	Yes	Every 3rd Bay	Every 3rd Bay
30 > 0 < 37.5	6	7	3	5	Yes	Every 3rd Bay	Every 3rd Bay
37.5 > 0 < 45	6	7	3	5	Yes	Every 3rd Bay	Every 3rd Bay

Braced Installation

85 mph Wind Load 0 psf Snow

Wind and Snow Load	Braced Installation						
	Max (PS)		12" Dia Pier		Required Braces		
Horizontal pipe spans	Sch 40	Sch 80	Short	Tall	A	E	F
15	15	3	3	Yes	Yes	Yes	Yes
15	15	3	3	Yes	Yes	Yes	Yes
15	15	3	3	Yes	Yes	Yes	Yes
15	15	3	5	Yes	Yes	Yes	Yes
10	12	3	6	Yes	Yes	Yes	Yes
9	10	3	6	Yes	Yes	Yes	Yes
8	9	3	6	Yes	Yes	Yes	Yes

Layout Your System

Typically most ground mounted arrays are installed in a landscape configuration, with the long side of the PV modules horizontal and the rails running up the slope. This is different from roof mount installations which typically are in a portrait configuration with the long side of the module running up slope and the rails running horizontally.

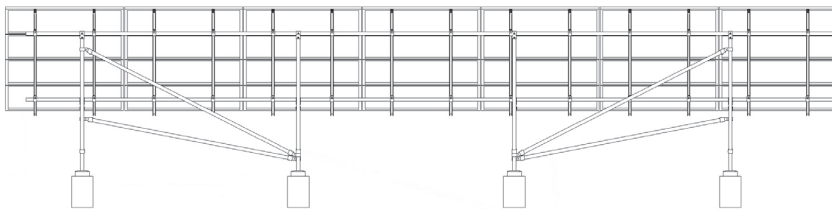
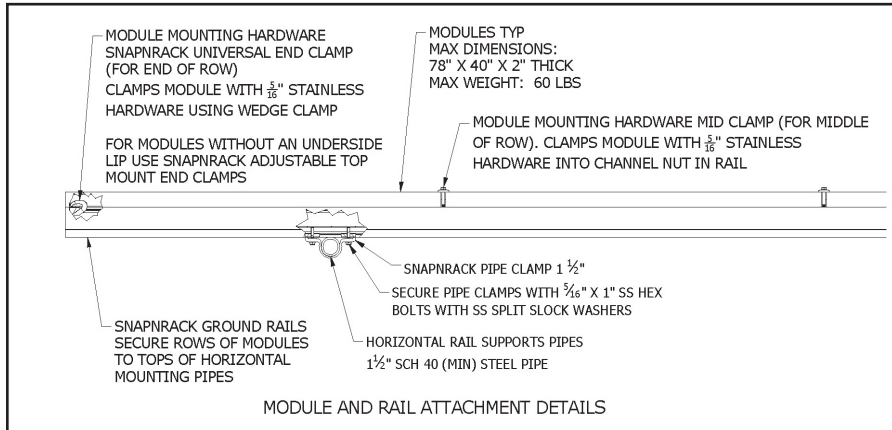

Layout rails so that module frame ends do not overhang mounting rails by more than 25% of total module frame length. Verify that mounting rail spans are in accordance with the Configuration Table in your state's Engineering Letter. Also, verify that rail ends do not overhang by a distance greater than 30% of the acceptable rail span specified in the same table.

Submit array plans to local permitting jurisdiction and proceed with the layout only when all permits for the project have been granted by the authority having jurisdiction.

Series 200 UL Ground Mounted System

Notes

- Module mid clamps are installed between modules in a row and require 0.5 inch of space between the modules.
- X clamps require 1.5 inches of extra rail to extend past the end of the module frame.
- When installing multiple rows of modules, a minimum spacing gap of 1/8 inch should be used between columns.
- Layout rails such that module frame ends do not overhang mounting rails by more than 25% of total module length.

Engineering Letter Download

- All Engineering Letters for each state are available for download at www.SnapNrack.com/structural-engineering

Design Tools

- SnapNrack has a suite of design tools to help configure your PV installation to be an accurate and fast install. Please visit us at: www.SnapNrack.com

Required Tools:

- 1 12" diameter Excavation Drill Auger
- 2 Portable Band Saw (18 tpi)
- 3 Concrete Mixer
- 4 Basic Concrete Tools
- 5 String Line
- 6 Surveying Marker Pen or Paint

Materials Needed for Concrete Pier Install:

- 1 Sched 40 or 80 1-1/2" Pipe w/ 1.9" outside diameter (Local Supplier)
- 2 Rebar #4 (Optional)
- 3 Concrete/ Concrete Mix

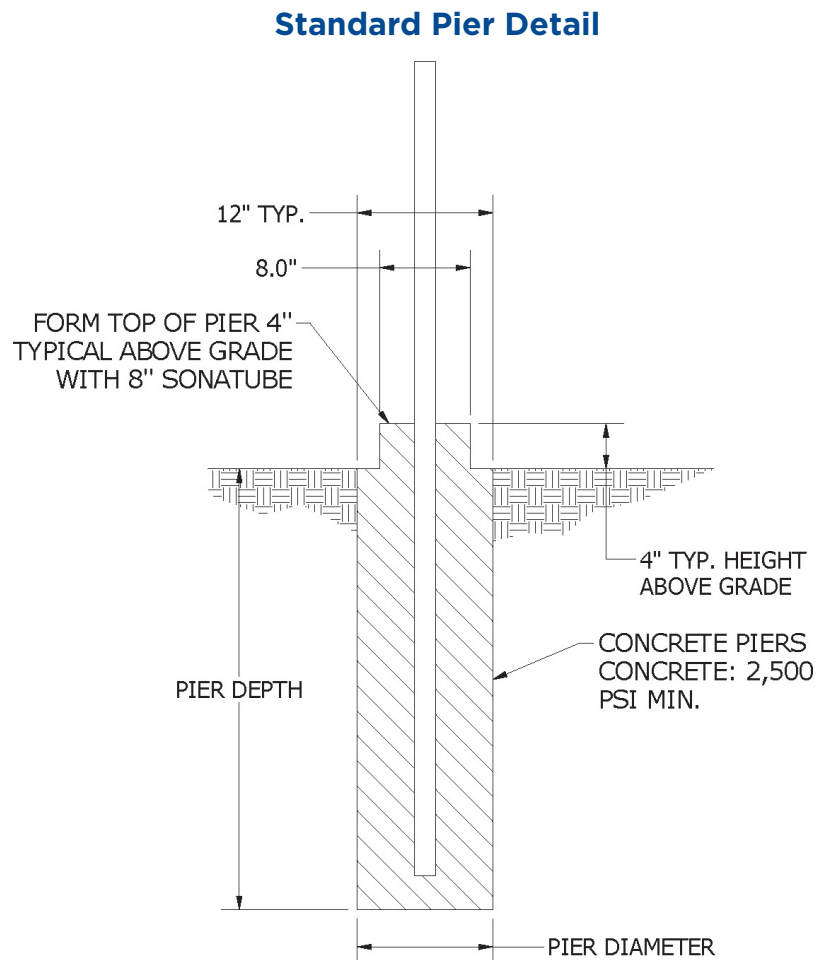

1) Excavate hole



2) Pour concrete



3) Place post



4) Measure & cut posts



Series 200 UL Ground Mounted System

Step-by-Step Instructions

1) Prepare to excavate holes by measuring and staking hole locations. Set first stake and run a string perpendicular to true South and set second stake. Stake remaining corners of the array according to the plan layout. Excavate core footings at marked location to the depth indicated in your state's Engineering Letter. Footing size may vary depending on job-specific conditions. All conditions should be reviewed by customer's site engineer.

2) Pour mixed concrete into excavated holes.

3) Insert posts into wet concrete and move posts up and down to ensure concrete fills inside of posts. Bottom of posts cannot be in contact with dirt. Set sonotubes at ground level centered on vertical, and fill with concrete. Use string line grid and post level to place verticals square and plumb. (Do not set sonotube in the concrete, as this will make removal difficult.) Smooth concrete.

4) Determine the proper angle for the module array and calculate the length of the vertical posts. Front posts should be maximum 48" above grade tilt angle, tilt angle maximum 48 degrees. Supports vertical pipes at the proper height and angle until the concrete piers are set. Use a string line to ensure alignment of posts.



Notes

- To speed up installations, it is recommended to use a 12-inch power auger to dig the footings.

- Before you dig any holes, contact all utilities in the area to locate any underground lines, pipes, and wiring.

- Before concrete completely cures, be sure to make final adjustments to posts.

Design Tools

- SnapNrack has a suite of design tools to help configure your PV installation to be an accurate and fast install. Please visit us at: www.SnapNrack.com

Required Tools:

- ① Backhoe tractor with 12" Bucket
- ② Concrete Mixer
- ③ Basic Concrete Tools String Line
- ④ Surveying Marker Pen or Paint

Materials Needed for Grade Beam Install:

- ① Sched 40 or 80 1-1/2" Pipe w/ 1.9" outside diameter (Local Supplier)
- ② Rebar #4
- ③ 2x4 for bracing pipes

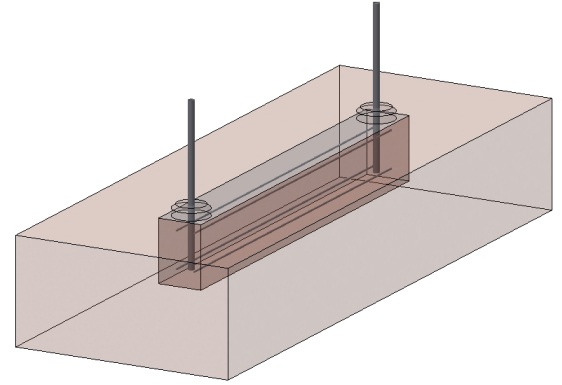

Grade Beam Foundation Detail

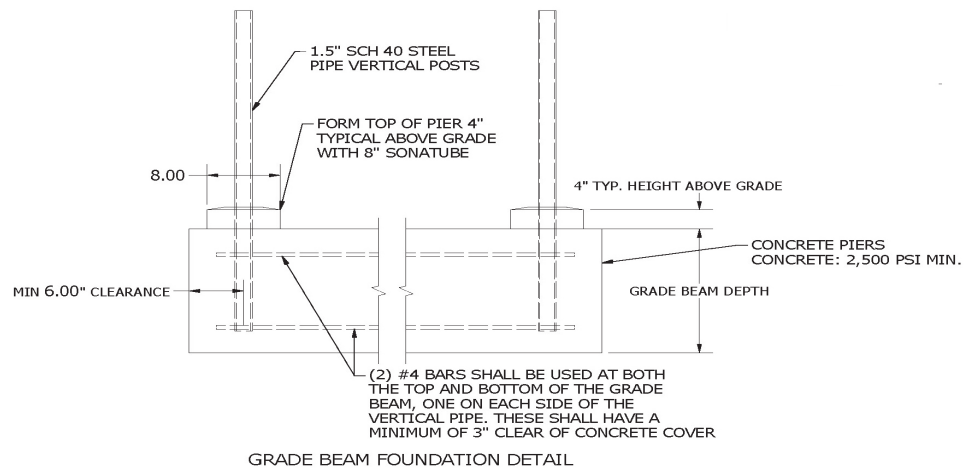

Conversion Chart for Pier to Grade Beam Footings

Conversion Chart for Pier to Grade Beam Footings			
12 dia. Pier Depth	12" wide Grade Beams	18" wide Grade Beams	24" wide Grade Beams
	Depth (in)	Depth (in)	Depth (in)
3 ft	12	12	12
4 ft	17	15	13
5 ft	20	18	17
6 ft	24	22	20
7 ft	29	26	23

12" Wide Grade Beam Footing Option

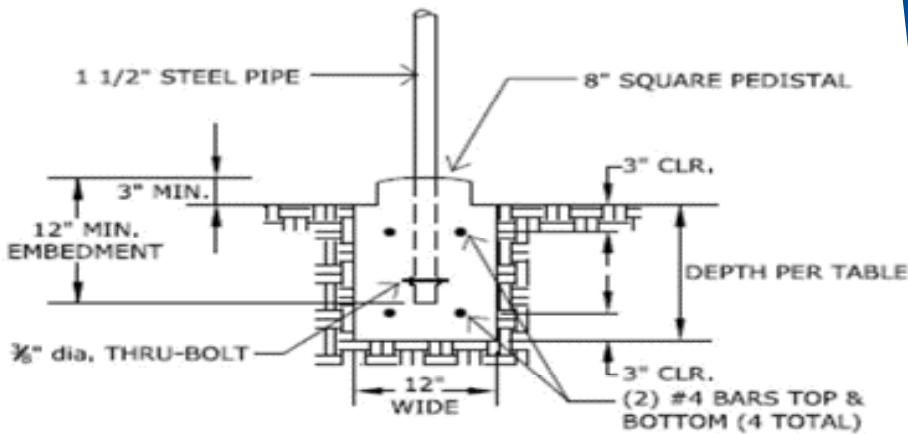

18" Wide Grade Beam Footing Option

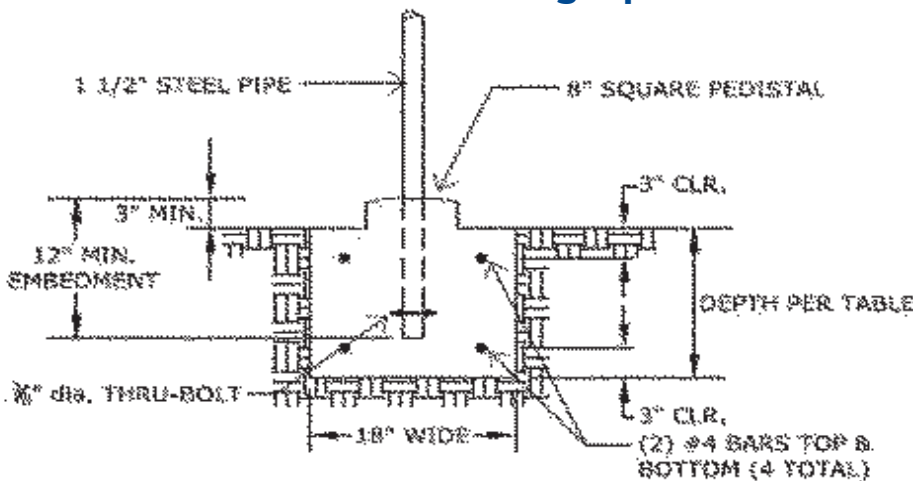

24" Wide Grade Beam Footing Option

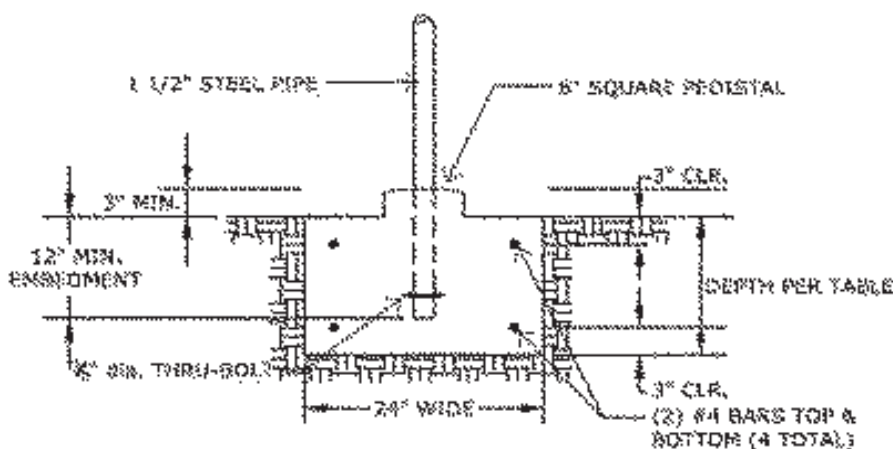

Series 200 UL Ground Mounted System

Step-by-Step Instructions

1) Prepare to excavate grade beams by measuring and staking hole locations. Set first stake and run a string perpendicular to true South and set second stake. Stake remaining corners of the array according to the plan layout. Excavate grade beams at marked location to the depth indicated in your state's Engineering Letter. Grade beam size may vary depending on job-specific conditions. All conditions should be reviewed by customer's site engineer.

2) Pour mixed concrete into excavated grade beams.

3) Insert posts into wet concrete and move posts up and down to ensure concrete fills inside of posts. Bottom of posts must not be in contact with dirt. Use string line grid and post level to place verticals square and plumb. (Do not set sonotubes in the concrete, as this will make removal difficult.) Smooth concrete.

4) Determine the proper angle for the module array and calculate the length of the vertical posts. Front posts should be maximum 48" above grade tilt angle, tilt angle maximum 48 degrees. Supports vertical pipes at the proper height and angle until the grade beams are set. Use a string line to ensure alignment of posts.

Notes

- Before you dig any holes, contact all utilities in the area to locate any underground lines, pipes, and wiring.

- A site specific analysis is required when using a grade beam option at locations with a design wind speed of 120 mph or higher.

Design Tools

- SnapNrack has a suite of design tools to help configure your PV installation to be an accurate and fast install. Please visit us at: www.SnapNrack.com

Required Tools:

- ① Allen Wrench
- ② Portable Band Saw
- ③ Measuring Tape

Materials Needed for Standard Bracing Install:

- ① Sched 40 or 80 1-1/2" Pipe (Local Supplier)
- ② Single Socket Tee
- ③ End Caps
- ④ Galvanized Spray

Socket Tee to Post

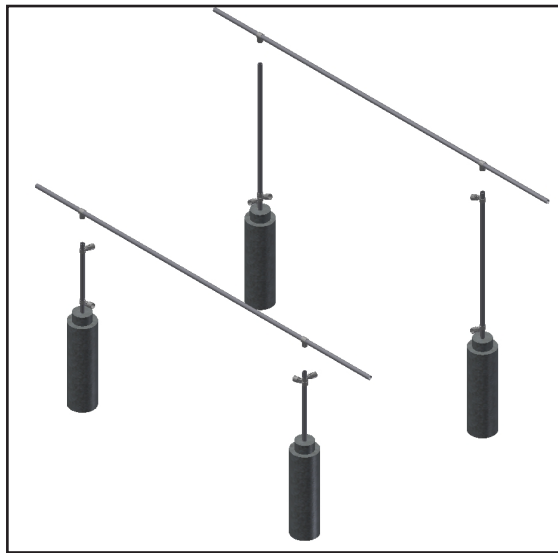

Horizontal Pipes with Bracing

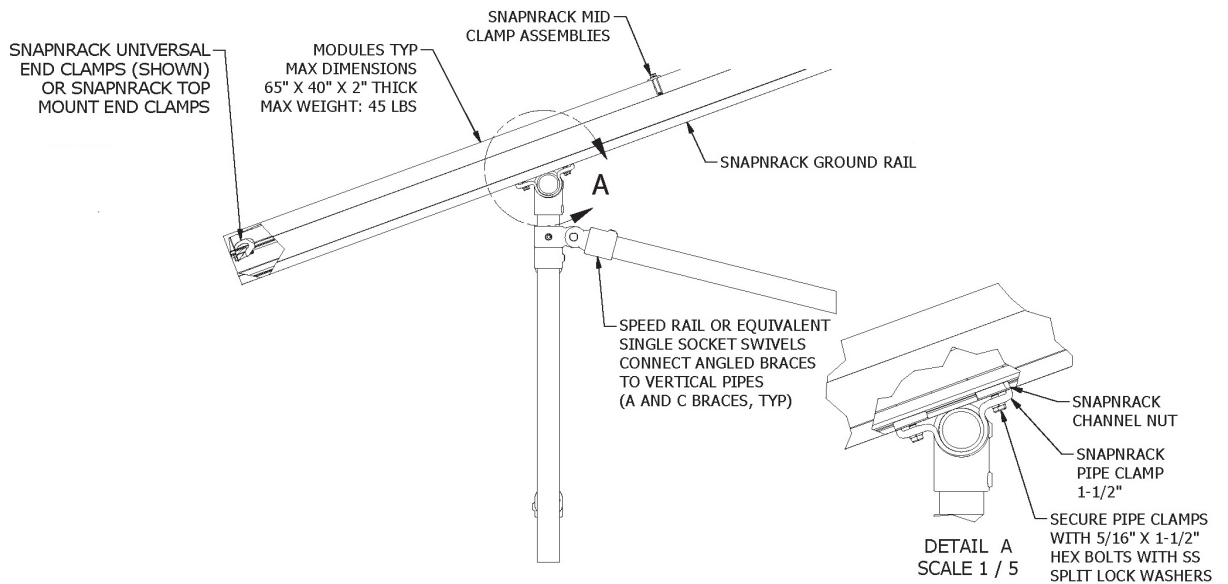
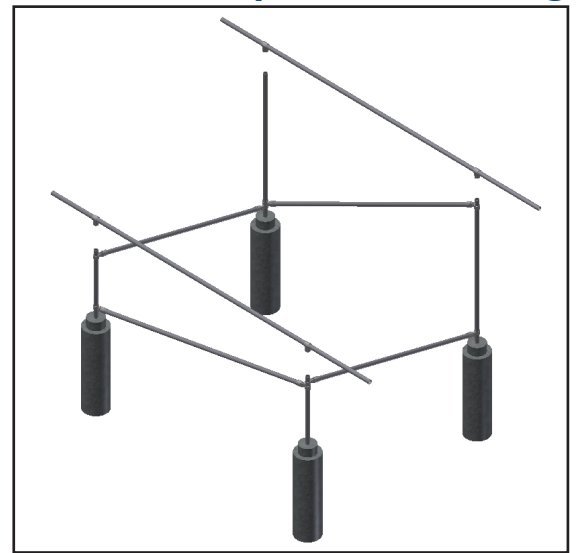

1) Slide all brace fittings onto posts



2) Install socket tees

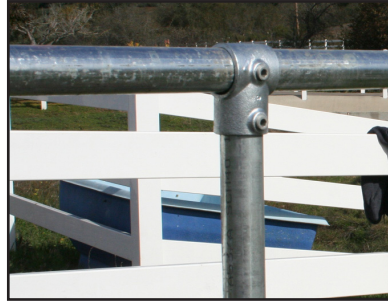

3) Install horizontal pipes



4) Install bracing pipes



Series 200 UL Ground Mounted System

Step-by-Step Instructions

1) Determine the necessary cross bracing and required structural fittings before horizontal pipes are installed. Slide all fittings onto vertical pipes to meet bracing plan. If needed, cross bracing will be specified on the plans and in the BOM (needed if verticals are over 5').

2) Determine the required number of single socket tees and slide onto the horizontal pipes. Connect designated tees to vertical posts.

3) Set horizontals in place and check for proper leveling and angle (pitch). Use a rail to check along entire length of array for proper pitch. Use existing rigid couplers to connect long pieces together. Make sure to leave some extra on each end in case of errors. Run structural fittings in to place.

4) Measure, cut, and install bracing pipes. Measure the distance between each brace fitting on the vertical posts and then cut to measured length. Once braces are installed, tighten allen screws of fittings.

Please note that the online Configuration Tool estimates the brace lengths (to ensure you purchase enough pipe), but actual field measurements should be taken and used.

Notes

- Make sure verticals are plumb and set before installing cross bracing.
- Check to make sure that the allen screws on the structural fittings are accessible for tightening.
- Online configuration tool estimates brace lengths, but actual field measurements should be taken and used.

Design Tools

- SnapNrack has a suite of design tools to help configure your PV installation to be an accurate and fast install. Please visit us at: www.SnapNrack.com

Series 200 UL

Braced Option

Required Tools:

- ① Allen Wrench
- ② Portable Band Saw
- ③ Measuring Tape

Materials Needed for Standard Bracing Install:

- ① Sched 40 or 80 1-1/2" Pipe (Local Supplier)
- ② Single Socket Tee
- ③ Swivel Socket Tee
- ④ End Caps
- ⑤ Galvanized Spray

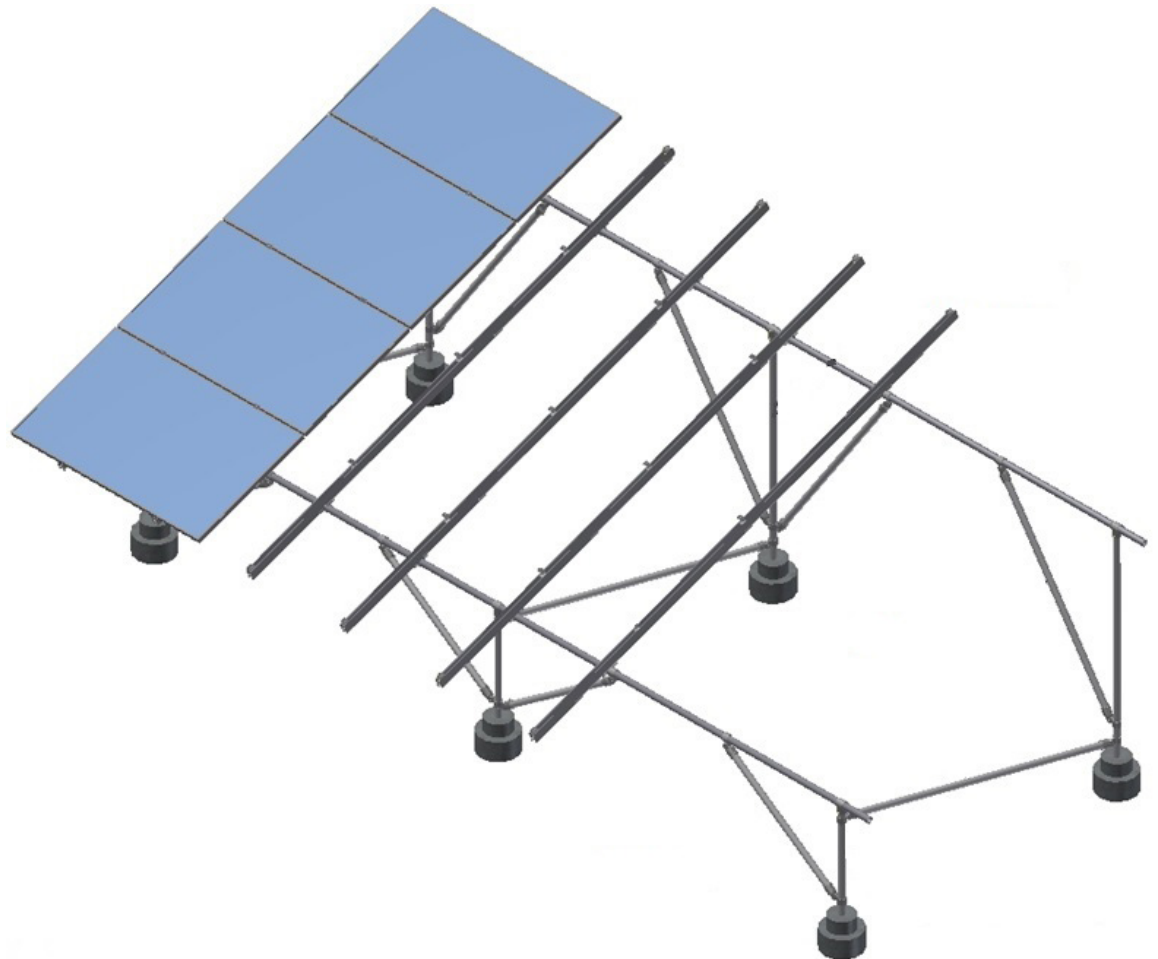

1) Slide all brace fittings onto posts



2) Install socket tees



3) Install horizontal pipes



4) Install bracing pipes



Series 200 UL Ground Mounted System

Step-by-Step Instructions

1) Determine the necessary cross bracing and required structural fittings before horizontal pipes are installed. Slide all brace fittings onto vertical pipes. If needed, cross bracing will be specified on the plans and in the BOM (needed if verticals are over 5').

2) Determine the required number of single socket tees and slide onto the horizontal pipe. Connect designated tees to vertical posts.

3) Set horizontals in place and check for proper leveling and angle (pitch). Use a rail to check along entire length of array for proper pitch. Use existing rigid couplers to connect long pieces together. Run structural fittings in to place.

4) Measure, cut, and install bracing pipes. Measure the distance between each brace fitting on the vertical posts and then cut to measured length. Brace E and F are to be attached to the horizontal at 1/3 the distance between the two posts. Once braces are installed, tighten allen screws of fittings.

Notes

- Make sure verticals are plumb and set before installing cross bracing.
- Make sure to leave extra length on each end in case of errors.
- Check to make sure that the allen screws on the structural fittings are accessible for tightening.
- Online configuration tool estimates brace lengths, but actual field measurements should be taken and used.

Design Tools

- SnapNrack has a suite of design tools to help configure your PV installation to be an accurate and fast install. Please visit us at: www.SnapNrack.com

Required Tools:

- 1 Level
- 2 String Line or Spare Rail
- 3 Pitch Meter
- 4 1/2" Socket Wrench
- 5 5/32" Allen Key
- 6 Torque Wrench

Materials Needed to Install Rails:

- 1 Ground Rail
- 2 Pipe Clamp Assemblies



Pipe Clamp to Rail Assembly

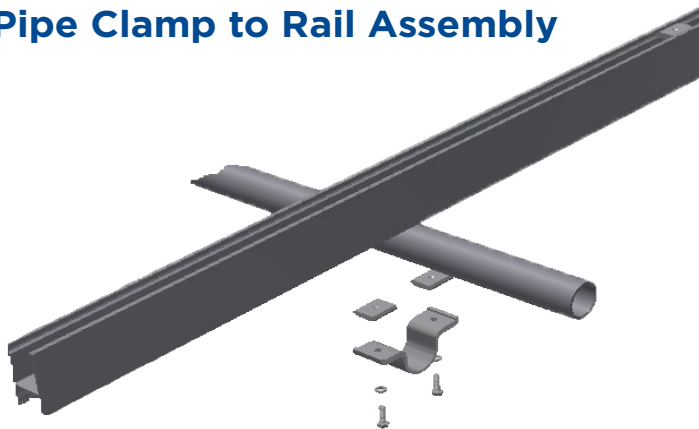

Materials Included In Wire Clips:

- 1 (1) SnapNrack Wire Clip



Dimensioned Wire Clip



Pipe Clamps
Torque:
12ft-lbs

1) Determine rail layout



2) Place pipe clamps & rails



3) Attach rails



4) Square & level rails



SnapNrack Wire Clip

1) Place all conductors



2) Snap on clip

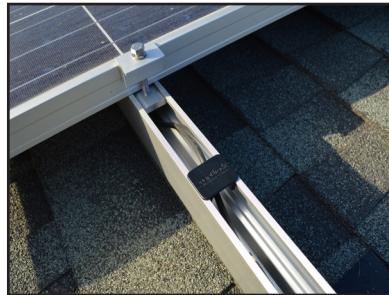

Series 200 UL Ground Mounted System

Step-by-Step Instructions

1) Find center of array and mark edges of each module on the lower horizontal pipe. Determine the distance from the lower horizontal to the edge of the rail. Mark all rails at this distance.

2) Place pipe clamps on horizontal rails where markings are placed. Next, place rails where markings are placed.

3) Attach rails with the pipe clamps by snapping-in the bonding channel nuts to rail. Channel nuts are designed to snap in and out of rail channels. This enables you to quickly assemble systems without having to slide inserts from the end of the rail. Then tighten bolts to create a secure attachment to pipes. Pipe clamps torque to 12 ft-lbs.

4) Use a 3-4-5 to square one rail and tighten. Transfer distances from the lower horizontal to the upper horizontal, maintaining a common reference point. Tighten rails at your marks. Double check squareness by checking corner to corner distances (diagonals). If the rails are of equal length, and are parallel, the diagonal distances should be equal.

SnapNrack Wire Clip

1) Place all electrical conductors in the bottom of the rail channel

2) Install the wire clip by snapping it into place on the rail. All electrical conductors are now securely enclosed in the rail.

Design Tools

- SnapNrack has a suite of design tools to help configure your PV installation to be an accurate and fast install. Please visit us at: www.SnapNrack.com

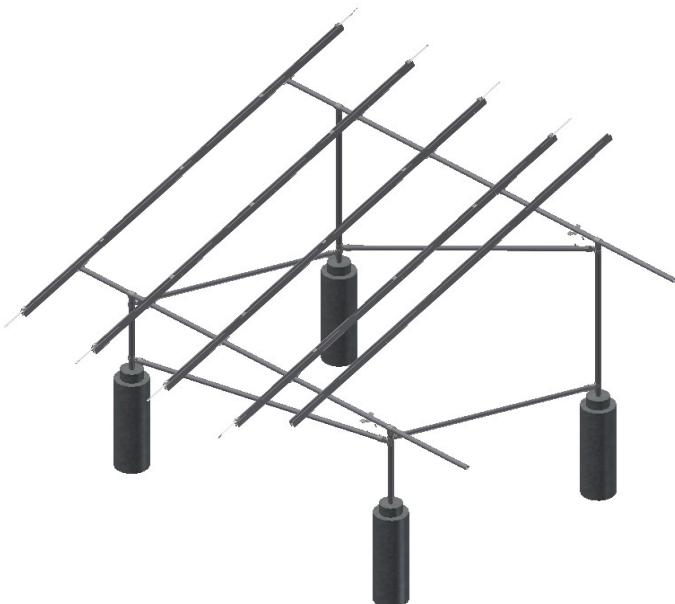

Required Tools:

- ① 1/2 inch Socket Wrench
- ② Torque Wrench

Materials Needed to Install Mid & End Clamps:

- ① Pre Installed SnapNrack Pipe Structure Attachments
- ② Pre Installed SnapNrack Rails
- ③ SnapNrack Mid Clamp Assemblies
- ④ SnapNrack End Clamp Assemblies
- ⑤ PV Modules

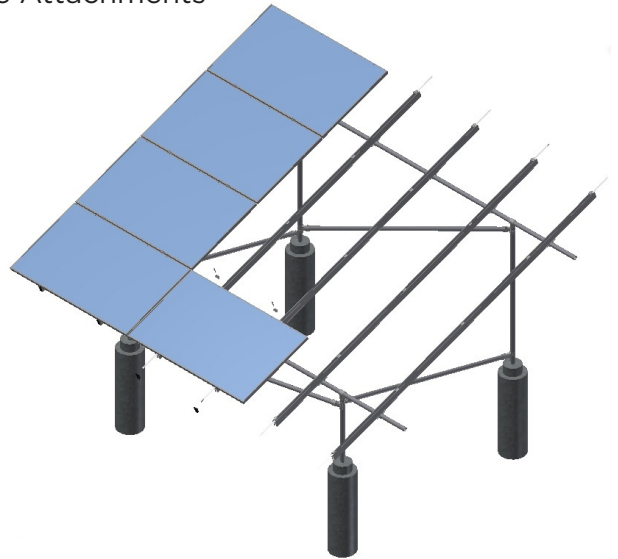

Mid Clamp Assembly:

- ① (1) 5/16in - 18 X 2 1/2in SS HCS Bolt
- ② (1) 5/16in SS Split Lock Washer
- ③ (1) SnapNrack Mid Clamp
- ④ (1) 5/16in - 18 SnapNrack Bonding Channel Nut

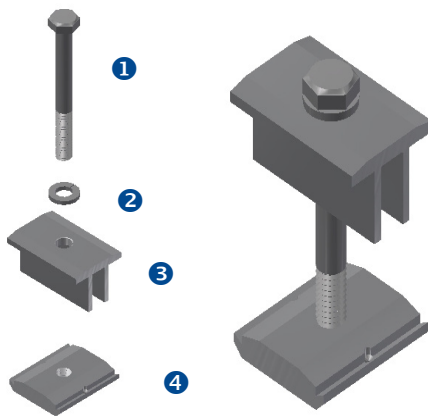

X Clamp Assembly:

- ① (1) 5/16in - 18 2x3/4in SS HCS Bolt
- ② (1) 5/16in SS Split Lock Washer
- ③ (1) SnapNrack Self Adjusting Top
- ④ (1) SnapNrack Self Adjusting Bottom

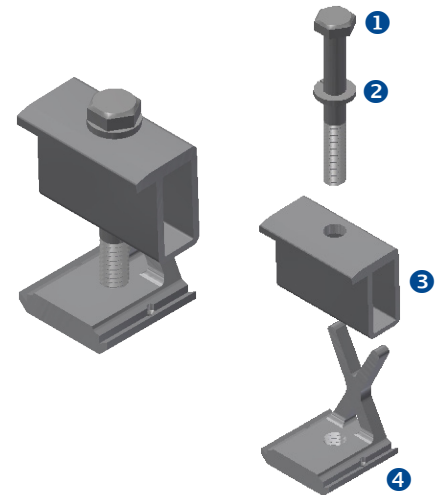

Universal End Clamp Assembly:

- ① (1) 5/16in - 18 X 1 1/2in SS HCS Bolt
- ② (1) 5/16in X 3/4in SS Flat Washer
- ③ (1) SnapNrack Universal Wedge
- ④ (1) SnapNrack Universal Wave

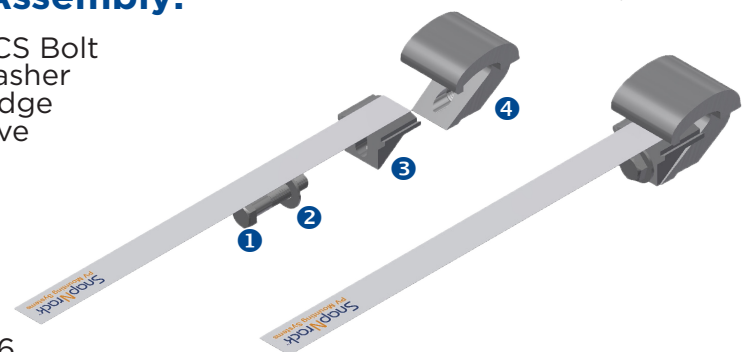

SnapRack Mid Clamp

1) Snap into channel



2) Set mid clamp & modules

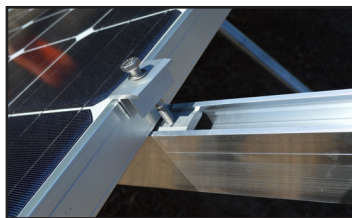

3) Tighten



Torque:
Silver 10-16
ft-lbs. Black
8-10 ft-lbs.

SnapRack X Clamp

1) Snap into channel



2) Set on module

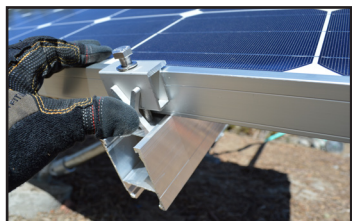

3) Tighten



SnapRack Universal End Clamp

1) Set in rail



2) Place module



3) Pull tab forward



4) Set end cap



Series 200 UL Ground Mounted System

Step-by-Step Instructions

SnapRack Mid Clamp

- 1) Snap the preassembled SnapRack Mid Clamp's channel nut into the top channel of the rail.
- 2) Slide the mid clamp flush to the module with the top lip of the mid clamp over the top edge of the module. Place the next module flush to the other side of the mid clamp.
- 3) Tighten hardware, torque silver hardware to 10-16 ft-lbs and black hardware to 8-10 ft-lbs.

SnapRack X Clamp

- 1) Snap the preassembled SnapRack X Clamp's channel nut into the top channel of the rail.
- 2) Slide the x clamp flush to the edge of the module with the lip of the top of the end clamp over the top of the module and lip of the bottom of the end clamp under the module.
- 3) Tighten hardware, torque silver hardware to 10-16 ft-lbs and black hardware to 8-10 ft-lbs.

SnapRack Universal End Clamp

- 1) Slide the preassembled SnapRack Universal End Clamp into the end of the rail.
- 2) Lift the module and slide the universal end clamp under the module far enough to pass the lip of the bottom edge of the module.
- 3) Use the pull tab to pull the universal end clamp tight to the end of the rail.
- 4) Hold and tighten the universal end clamp to 10 - 16 ft-lbs. Then install rubber end cap to finish.

Notes

- Universal End Clamp (UEC) does not bond module to rail, the UEC is bonded to the module frame. Be sure to separately ground any modules that only secured by UECs, especially during servicing.

Design Tools

- SnapRack has a suite of design tools to help configure your PV installation to be an accurate and fast install. Please visit us at: www.SnapRack.com

System Ground Methods Include:

- SnapNrack Bonding Lug
- IlSCO Bonding Lug

UL 2703 Listing ensures that all components in the system include modules are bonded when a system ground is properly installed.

1 system ground is required per individual array section.

SnapNrack Bonding Lug Assembly

SnapNrack Bonding Lug must be torqued to 16 ft-lbs

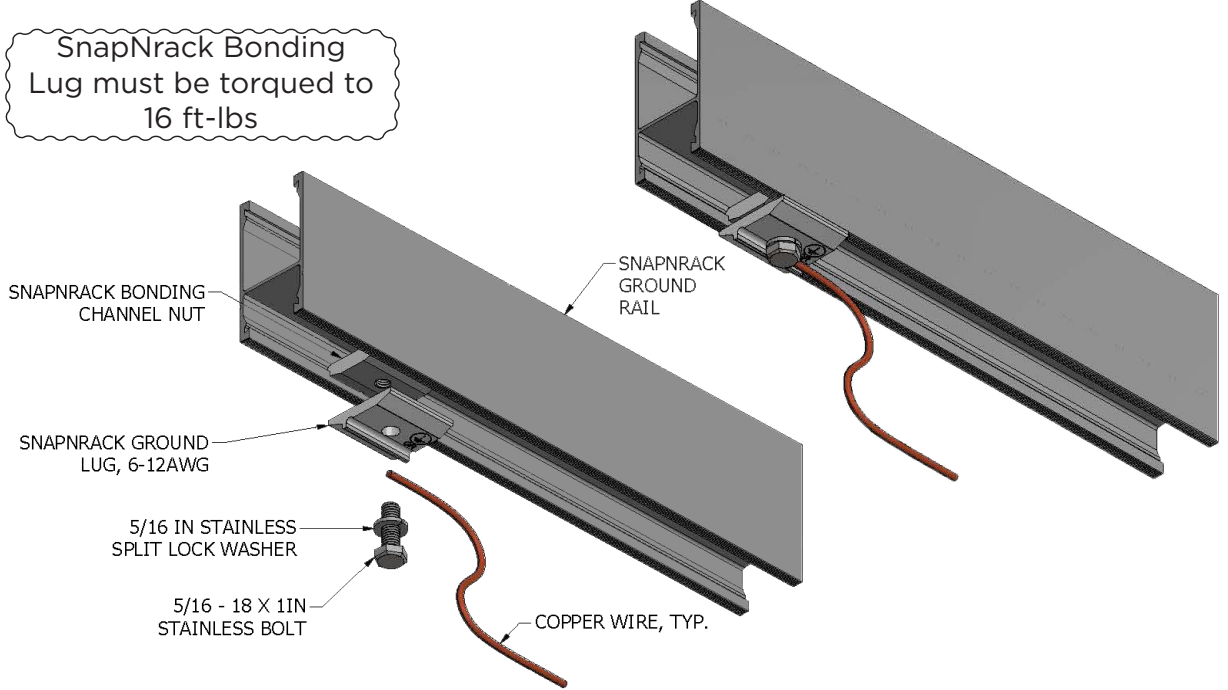

IlSCO Bonding Lug Assembly

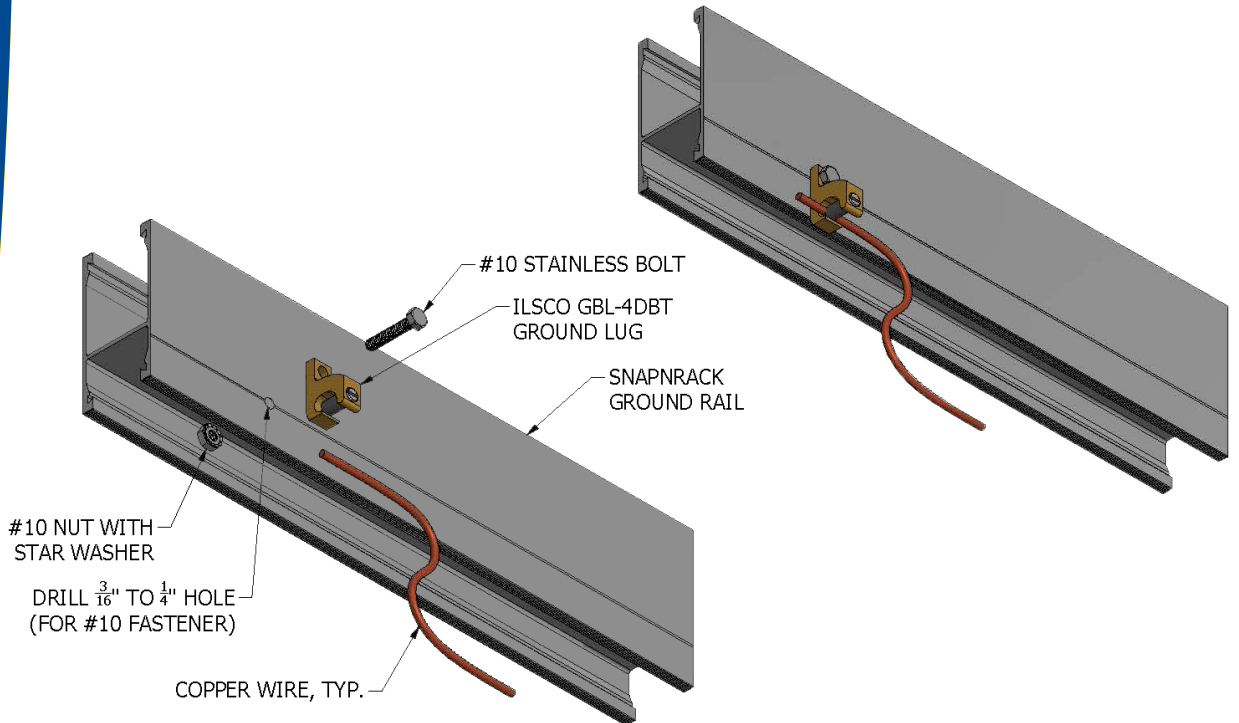

SnapRack Bonding Lug

1) Snap in Bonding Lug

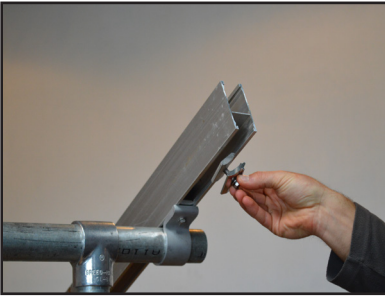

2) Attach grounding

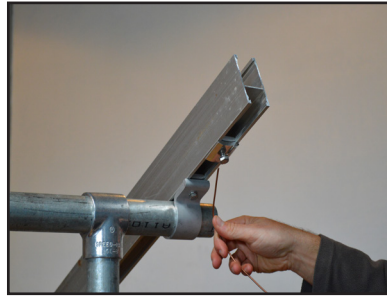

3) Tighten hardware

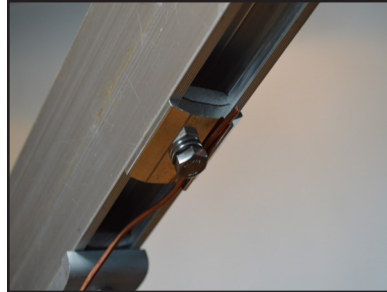
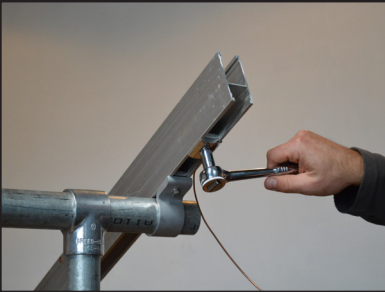

IlSCO Bonding Lug

1) Drill hole for IlSCO Lug



2) Attach IlSCO Lug



3) Attach grounding



4) Tighten hardware

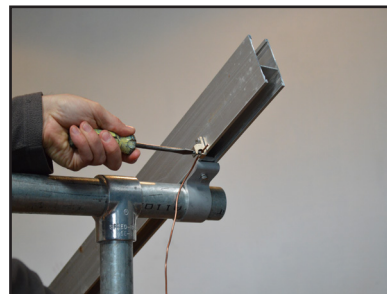

Series 200 UL Ground Mounted System

Step-by-Step Instructions SnapRack Bonding Lug

1) Snap in the SnapRack Bonding Lug in to the rail channel.

2) Attach grounding conductor into slot and tighten bolt to 7 ft-lbs.

3) Tighten all hardware to a min of 10 ft-lbs.

Step-by-Step Instructions IlSCO Bonding Lug

1) Using a 3/8" drill bit, drill a hole in the back side of the for attachment of the IlSCO Lug

2) Place the bolt through the hole and attach the lug assembly.

3) Attach grounding conductor into slot and tighten bolt to 7 ft-lbs.

4) Tighten all hardware to a min of 10 ft-lbs

Notes

- System has been evaluated to a maximum overcurrent device (OCD) protection level of 20 Amps.

- SnapRack Bonding Lug may be used in bottom or top slot.

- SnapRack Bonding Lug may be rotated 90 degrees relative to slot.

- Grounding with a standard IlSCO GBL-4DBT Lug is a listed alternate and requires drilling of a hole in the rail.

- Hardware connection to rail: 5 ft-lbs.
Torque for lug set screw: #10-#14 Copper- 20in-lb, #8-#14 Copper- 25in-lb, #4-#6 Copper- 35in-lb

- It is convenient to install grounding hardware as modules are installed but this will vary with the type of PV modules.

- The Wiley Electronics WEEB is an acceptable grounding method. If you are using universal end clamps, the rail can be trimmed flushed with the module frame.

Design Tools

- SnapRack has a suite of design tools to help configure your PV installation to be an accurate and fast install. Please visit us at: www.SnapRack.com

