



July 5, 2011

Revised Fig.2 on Page 9 on 12/13/2011

Report Revised on 01/11/2012 for Editorial Changes Only

Project Number 111316C

Mr. Stewart Wentworth

QUICK MOUNT PV

936 Detroit Avenue, Suite D
Concord, CA 94518-2539

Subject: Quick Mount QBase with 6.5" Post as Used in Low Slope Mount (QMLSH-7) & Universal Tile Mount (QMUTM) Load Testing

Dear Mr. Wentworth:

As requested, Applied Materials & Engineering, Inc. (AME) has completed load-testing the QMLSH-7 hardware. The purpose of our testing was to evaluate the tensile and shear load capacity of the QMLSH-7 hardware attached to a commercially available 2"x4" Douglas Fir rafter.

SAMPLE DESCRIPTION

Nine (9) mockup samples were delivered to our laboratory on June 17, 2011. Mockup configuration consisted of three 16" long rafters at 7" o.c., screwed to 1/2" Structural 1 plywood. The 7" (finished height) Quick Mount Standoff (QMSO) hardware is attached through the plywood into the rafter with two 5/16"x3" lag bolts torqued to 15ft-lbs. Product hardware drawings are provided in Appendix A.

TEST PROCEDURES & RESULTS

1. Tensile Strength

Three samples were tested for tensile strength on June 29, 2011 using a United Universal testing machine. Samples were rigidly attached to the testing machine and a tensile load was applied to the 5/16"x1" machine bolt connected to the aluminum post. The samples were loaded in tension at a constant rate of axial deformation of 0.05 in./min. without shock until failure occurred. Based on the above testing, the average ultimate tensile load of the QMLSH-7 hardware in Douglas Fir was determined to be 3031 lbf.

The specific gravity and moisture content of the rafter was tested in accordance with ASTM D2395, Method A (oven-dry). The average specific gravity and moisture content was determined to be 0.436 and 20.9%, respectively. Detailed results are provided in Table I. Test setup is illustrated in Figure 1 of Appendix B.

Mr. Stuart Wentworth
QUICK MOUNT PV
Quick Mount QBase with 6.5" Post as Used in Low Slope Mount
(QMLSH-7) & Universal Tile Mount (QMUTM) Load Testing
July 5, 2011

Project Number 111316C

2. Shear Strength Parallel to Rafter

Three samples were tested for shear strength on June 29, 2011 using a United Universal testing machine. Samples were rigidly attached to the testing machine and a shear load was applied to the 5/16"x1" machine bolt connected to the aluminum standoff. The samples were loaded parallel to rafter at a constant rate of axial deformation of 0.01 in./min. without shock until failure occurred. Based on the above testing, the average ultimate shear load, parallel to rafter, of the QMLSH-7 hardware in Douglas Fir was determined to be 803 lbf.

The specific gravity and moisture content of the rafter was tested in accordance with ASTM D2395, Method A (oven-dry). The average specific gravity and moisture content was determined to be 0.438 and 13.8%, respectively. Detailed results are provided in Table II. Typical test setup is illustrated in Figure 2 of Appendix B.

3. Shear Strength Perpendicular to Rafter

Three samples were tested for shear strength on June 30, 2011 using a United Universal testing machine. Samples were rigidly attached to the testing machine and a shear load was applied to the 5/16"x1" machine bolt connected to the aluminum standoff. The samples were loaded perpendicular to rafter at a constant rate of axial deformation of 0.01 in./min. without shock until failure occurred. Based on the above testing, the average ultimate shear load, perpendicular to rafter, of the QMLSH-7 hardware in Douglas Fir was determined to be 583 lbf.

The specific gravity and moisture content of the rafter was tested in accordance with ASTM D2395, Method A (oven-dry). The average specific gravity and moisture content was determined to be 0.451 and 16.5%, respectively. Detailed results are provided in Table III. Typical test setup is illustrated in Figure 2 of Appendix B.

If you have any questions regarding the above, please do not hesitate to call the undersigned.

Respectfully Submitted,

APPLIED MATERIALS & ENGINEERING, INC.

Reviewed By:

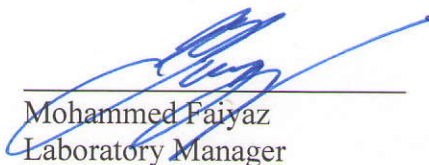
Mohammed Faiyaz
Laboratory Manager





Armen Tajirian, Ph.D., P.E.
Principal

TABLE I
LOW SLOPE MOUNT QMLSH-7
TENSILE LOAD TEST RESULTS
PROJECT NUMBER 111316C

SAMPLE ID	ULTIMATE TENSILE LOAD (LBF)	RAFTER MOISTURE CONTENT (%)	RAFTER SPECIFIC GRAVITY	FAILURE MODE
7PULL-1	2807	20.7	0.402	Lag bolt pull-out
7PULL -2	3283	22.0	0.476	Lag bolt pull-out
7PULL -3	3003	20.0	0.430	Lag bolt pull-out
AVERAGE	3031	20.9	0.436	..

TABLE II
LOW SLOPE MOUNT QMLSH-7
SHEAR LOAD PARALLEL TO RAFTER TEST RESULTS
PROJECT NUMBER 111316C

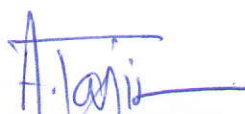
SAMPLE ID	ULTIMATE SHEAR LOAD PARALLEL TO RAFTER (LBF)	RAFTER MOISTURE CONTENT (%)	RAFTER SPECIFIC GRAVITY	FAILURE MODE
7PARA-1	863	14.2	0.436	Lag bolt pull-out
7PARA-2	877	13.2	0.444	Lag bolt pull-out
7PARA-3	670	14.1	0.434	Lag bolt pull-out
AVERAGE	803	13.8	0.438	..

TABLE III
LOW SLOPE MOUNT QMLSH-7
SHEAR LOAD PERPENDICULAR TO RAFTER TEST RESULTS
PROJECT NUMBER 111316C

SAMPLE ID	ULTIMATE SHEAR LOAD PERPENDICULAR TO RAFTER (LBF)	RAFTER MOISTURE CONTENT (%)	RAFTER SPECIFIC GRAVITY	FAILURE MODE
7PERP-1	609	14.1	0.434	Buckled plywood
7PERP-2	639	16.2	0.432	Buckled plywood
7PERP-3	500	19.1	0.488	Lag bolt pull-out
AVERAGE	583	16.5	0.451	..

APPENDIX A

Quick Mount PV[®]

Your *Solution* in Mounting Products

Solar • H₂O • Conduit • HVAC • Custom

Low Slope Mount Specifications

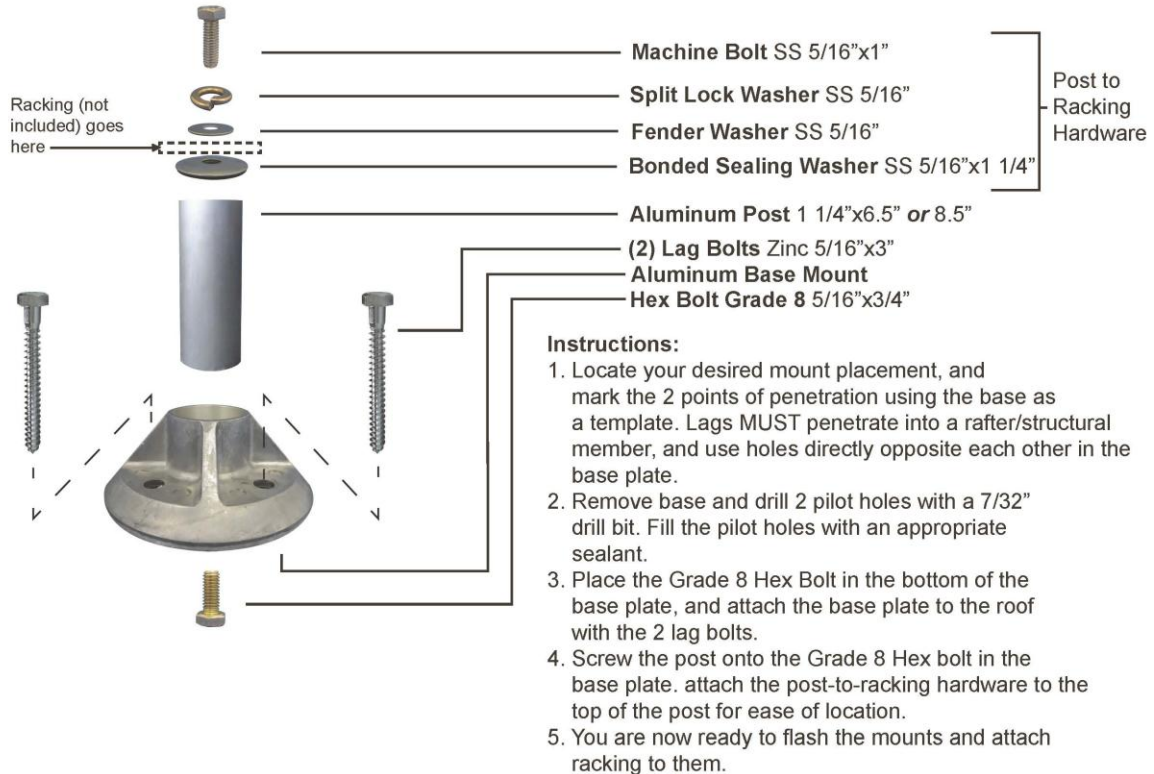

IMPORTANT-PLEASE READ:

This product DOES NOT include flashing, and therefore is not waterproof by itself. As the installer, it is your responsibility to make sure all roof penetrations are flashed properly!

Lag pull-out (withdrawal) capacities (lbs) in typical lumber:

Lag Bolt Specifications

	Specific Gravity	2/ea 5/16" shaft per 2.5" thread depth	5/16" shaft per 1" thread depth
Douglas Fir, Larch	.50	1330	266
Douglas Fir, South	.46	1175	235
Engelmann Spruce, Lodgepole Pine (MSR 1650 f & higher)	.46	1175	235
Hem, Fir	.43	1060	212
Hem, Fir, (North)	.46	1175	235
Southern Pine	.55	1535	307
Spruce, Pine, Fir	.42	1025	205
Spruce, Pine, Fir (E of 2 million psi and higher grades of MSR and MEL)	.50	1330	266

Sources: Uniform Building Code; American Wood Council

Notes: 1) Thread must be embedded in a rafter or other structural roof member.

2) Pull-out values incorporate a 1.6 safety factor recommended by the American Wood Council.

3) See IBC for required edge distances.

1 of 1

936 Detroit Ave Suite D, Concord, CA. 94518
 Phone: (925) 687-6686 Fax: (925) 687-6689
 Email: info@quickmountpv.com www.quickmountpv.com

APPENDIX B

LOW SLOPE MOUNT QMLSH-7

LOAD TEST SETUP

PROJECT NUMBER 111316C

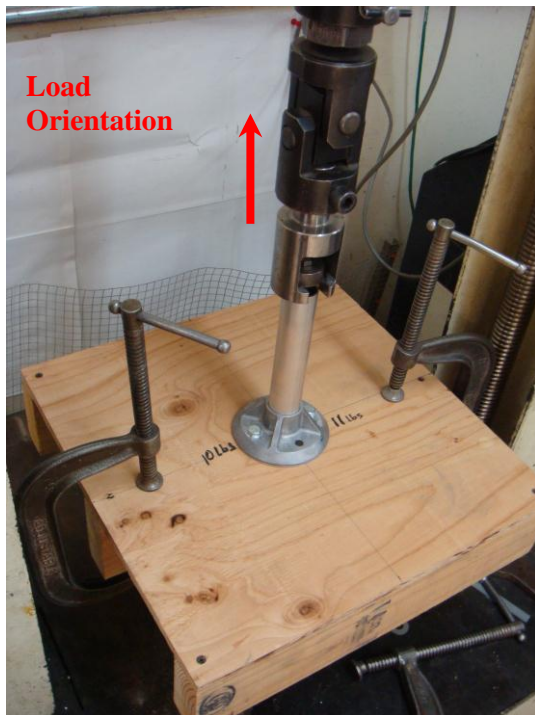

Figure 1. Tensile Test



Figure 2. Shear Test

Stamped Engineering Test Reports Do Not Expire

To whom it may concern,

Quick Mount PV offers extensive testing for all our products conducted by a third-party licensed professional engineer. All our third-party engineering reports are stamped by a licensed professional engineer at the time the reports were prepared and **do not expire**. Our engineering reports continue to be valid as long as the professional engineer's license (date within the stamp) was valid when the reports were prepared (the report date). Even if the license has expired between the time the engineering reports were prepared and the time when a local agency reviews them, the reports do NOT need to be re-stamped with a current stamp.

This information is written into California State law under the Professional Engineers Act within the Business and Professions Code (B&P Code §§ 6700-6799). The California Board for Professional Engineers and Land Surveyors (BPELS) provides further clarification of the code in their Guide to Engineering & Land Surveying for City and County Officials, page 12 section 27, which is cited below.

27. If the license has expired between the time the engineering documents were prepared and the time when the local agency's review is performed, do the documents need to be re-sealed by a licensee with a current license? (B&P Code §§ 6733, 6735, 6735.3, 6735.4)

As long as the license was current at the time the engineering documents were prepared, the documents do not need to be re-sealed prior to review by the local agency. However, any changes (updates or modifications) to the documents that are made following the review by the local agency would have to be prepared by a licensed engineer with a current license and those changes would have to be signed and sealed.

It should also be noted that as of January 1, 2010 professional engineers are not required to include their license expiration date when they sign and stamp engineering documents only the date that they signed the document (B&P Code §§ 6735, 6735.3, 6735.4, 6764, 8750, 8761 & 8764.5). Links to all of the codes and guides referenced in this letter may be found online at quickmountpv.com under FAQ. Please submit any further questions to tech@quickmountpv.com.

Sincerely,



Jennifer D. Alfsen, BSME
R&D Mechanical Engineer
Quick Mount PV