



**ATTENTION: Please Read this cover letter
BEFORE installing the Classic-SL**

**For help with the Classic, Classic Lite or Classic-SL please see our how to videos and extended documentation. Please visit this website: www.midnitesolar.com/classic
Before calling tech support, we recommend visiting this website for some of the most common issues.**

DANGER OF DEATH TO YOUR CLASSIC

Warning with Tigo modules Solar Mode must not be used or the Classic will not survive. MidNite does not recommend the use of Tigo Module Optimizers with the Classic. If Tigo modules must be installed Legacy P&O MUST be used.

When the Classic is used with Wind or Hydro a Clipper type device will most likely be needed to protect against over voltage. A battery based diversion load WILL NOT keep the Classic safe from over voltage. High input voltage is recorded and over voltage is not covered under warranty.

Never hook a Pump or other load to the Input side of the Classic. If a Load must be hooked to the input side of the classic the load and Classic need to have blocking diodes on them.

Never Parallel 2 Classics onto one PV array. If 2 Classic's have to be paralleled for wind or hydro (NOT SOLAR) there must be blocking diodes on each Classic.

For Larger systems with Large inverters and or multiple inverters (like the Radian or XW+ for example) it is important to use appropriate sized cables and bus bars or damage to the inverters or charge controllers can occur. Take a single XW+ E-Panel for example, it has a positive bus bar for Charge controller battery side connections. This bus bar is sufficient for 2 charge controllers, so if you needed 3 or more then you need to look at the best way to handle the amperage. Or a Dual Radian, for example, is actually 4 separate inverters. Proper size cables become very important as well as large enough battery banks. Most manufacturers of Battery based inverters recommend 100AH of battery per KW of solar modules. (Please consult the inverter manufacture for assistance with cable sizing etc)



This Manual covers models Classic 150-SL, 200-SL & 250-SL

The MidNite Solar Classic charge controller conforms to *UL 1741, Safety for Inverters, Converters, Controllers and Interconnection System Equipment for Use With Distributed Energy Resources, Second Edition, May 7, 1999 with revisions through January 28, 2010 and CAN/CSA C22.2 No. 107.1: 2001/09/01 Ed: 3 (R2006)*

MidNite Solar Inc. reserves the right to revise this document and to periodically make changes to the content hereof without obligation or organization of such revisions or changes unless required to do so by prior arrangement.

Disclaimer

Unless specifically agreed to in writing, MidNite Solar Inc.

(a) Makes no warranty as to the accuracy, sufficiency or suitability of any technical or other information provided in its manuals or other documentation.

(b) Assumes no responsibility or liability for loss or damage whether direct, indirect, consequential or incidental, which might arise out of use of such information. The use of any such information will be entirely at the user's risk.

Contact Information

Telephone: 360.403.7207

Fax: 360.691.6862

Email: customerservice@midnitesolar.com

Web: www.midnitesolar.com

Contents

Scope.....	5
Introduction.....	5
Classic SL Power Graphs & Sizing the Solar Array.....	8
Unpacking the Classic SL.....	10
Removing and installing the front cover on the Classic SL.....	10
Mounting the Classic SL.....	11
Wiring the Classic SL	13
DC Terminal Connector.....	17
Maximum and Minimum Wire Size	17
Over Current Protection and Wire Size Requirements	17
Current Rating.....	18
Over Current Protection.....	18
Long Distance Wire Runs	18

Battery Temperature Compensation	19
Battery Temperature Sensor Installation	19
Chassis Grounding	21
DC System Grounding	21
DC GFP (Ground Fault Protection)	22
Disabling GFP.....	23
Commissioning the Classic SL (Quick Start)	23
Equalization	23
Battery Charge Stages and Meanings	23
Resting	24
Mode is OFF	24
Adjusting Absorb, Equalize and Float Voltages	24
Current Limit.....	25
Calibrating Battery and PV Voltage	25
Configuring DC Input Source	25
Setting the Date and Time.....	26
Troubleshooting / FAQs	27
Electrical Specifications	35
Specifications Mechanical	36
Classic Breaker sizing.....	37

Scope

This Manual provides safety guidelines and installation information for the Classic SL charge controller. It does not provide brand specific information about photovoltaic panels, batteries etc. Contact the manufacturer of other components in the system for relevant technical data.

Introduction

The MidNite Classic SL charge controller was designed as a SOLAR only charge controller. The Classic 150-SL, 200-SL and 250-SL are designed to work with 12, 24, 36, 48, 60 and 72 volt battery banks. The Classic SL can be installed stand alone or as a multi-unit networked installation.

Standard features of the Classic SL charge controller include:

- *3 input operating voltage ranges 150, 200 and 250 VDC
- *Graphical display
- *Previous 380 days of operational data logged

This Manual covers *Classic 150-SL, Classic 200-SL and the Classic 250-SL*. It covers the installation, wiring and use of the Classic charge controller.



WARNING Warnings signs identify conditions or practices that could result in personal injury or loss of life.



CAUTION Cautions identify conditions or practices that could result in damage to the unit or other equipment.

MIDNITE SOLAR CHARGE CONTROLLER INSTALLATION GUIDELINES AND SAFETY INSTRUCTIONS

This product is intended to be installed as part of a permanently grounded electrical system as shown in the system configuration sections. The following important restrictions apply *unless superseded by local or national codes*:

- To use the Classic's built in DC GFP the System's DC Negative conductor must not be bonded to earth ground. The Classic does this with its internal Ground Fault Protection circuitry. The battery negative and ground are not bonded together directly but are connected together by the Classic's internal GFP device. All negative conductor connections must be kept separate from the grounding conductor connections. The equipment ground terminal inside the Classic must be connected to Earth Ground for the internal DC-GFP to work.
- With the exception of certain telecom applications, the Charge Controller should *never* be positive grounded.



- The Charge Controller equipment ground is marked with this symbol:
- If damaged or malfunctioning, the Charge Controller should only be disassembled and repaired by a qualified service center. Please contact your renewable energy dealer/installer for assistance. Incorrect reassembly risks malfunction, electric shock or fire.
- The Charge Controller is designed for indoor installation or installation inside a weatherproof enclosure. It must not be exposed to rain and should be installed out of direct sunlight.

For routine, user-approved maintenance:

- Turn off all circuit breakers, including those to the solar modules, batteries and related electrical connections before performing any maintenance.

Standards and Requirements

All installations must comply with national and local electrical codes; professional installation is recommended. The NEC in the USA requires a DC ground fault interrupter for all residential PV installations. The GFP (Ground Fault Protection) device is built into the Classic.

DC and Battery-Related Installation Requirements:

- ❖ All DC cables must meet local and national codes.
- ❖ Shut off all DC breakers before connecting any wiring.
- ❖ Torque all the Charge Controller's wire lugs and ground terminals to the specs found on page 21.
- ❖ Copper wiring must be rated at 75° C or higher.
- ❖ Keep cables close together (e.g., using a tie-wrap) as much as possible to reduce inductance.
- ❖ Ensure both cables pass through the same knockout and conduit to allow the inductive currents to cancel.
- ❖ DC battery over-current protection must be used as part of the installation on the input and output.
- ❖ Breakers between the battery and the Classic must meet UL489 standards.
- ❖ Breakers between the DC source and the Classic must meet UL1077 or UL489 standards.

Design the battery enclosure to prevent accumulation of hydrogen gas at the top of the enclosure. Vent the battery compartment from the highest point to the outside. A sloped lid can also be used to direct the flow of hydrogen to the vent opening. Sealed (AGM, Gel etc) batteries do not normally require ventilation. Consult your battery manufacturer for details.



WARNING: PERSONAL PRECAUTIONS DURING INSTALLATION

WARNING BATTERIES PRESENT RISK OF ELECTRICAL SHOCK, BURN FROM HIGH SHORT CIRCUIT CURRENT, FIRE OR EXPLOSION FROM VENTED GASES. FOLLOW PROPER PRECAUTIONS.

- ❖ Someone should be within range of your voice to come to your aid if needed.
- ❖ Keep plenty of fresh water and soap nearby in case battery acid contacts skin, clothing, or eyes.
- ❖ Wear complete eye protection. Avoid touching eyes while working near batteries. Wash your hands with soap and warm water when done.
- ❖ If battery acid contacts skin or clothing, wash immediately with soap and water. If acid enters an eye, flood the eye with running cool water at once for at least 15 minutes and get medical attention immediately following.
- ❖ Baking soda neutralizes lead acid battery electrolyte. Keep a supply on hand in the area of the batteries.
- ❖ NEVER smoke or allow a spark or flame in vicinity of a battery or generator.
- ❖ Be cautious to reduce the risk of dropping a metal tool onto batteries. It could short the batteries or other electrical parts that can result in fire or explosion.
- ❖ Never wear metal items such as rings, bracelets, necklaces, and watches when working with a battery or other electrical circuits. A battery can produce a short circuit current high enough to weld a ring or the like to metal, causing severe burns.

Classic SL Power Graphs & Sizing the Solar Array

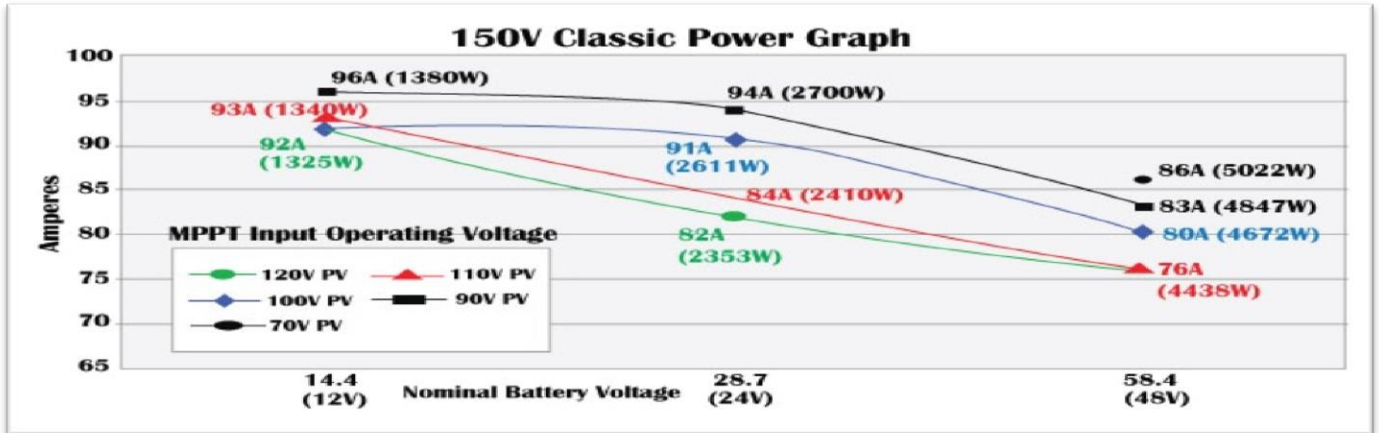

Table 1

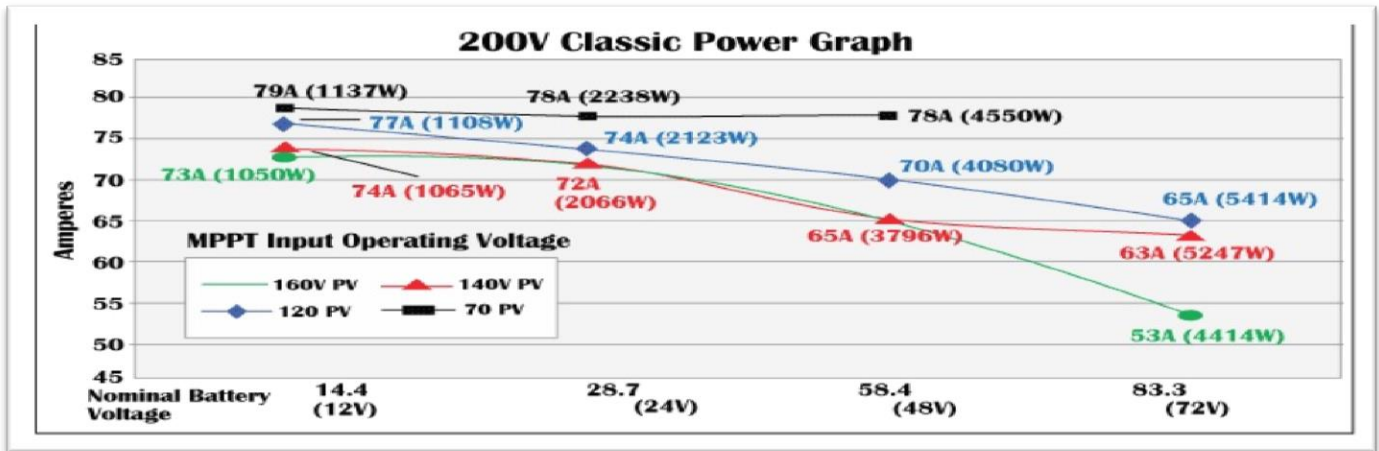

Table 2

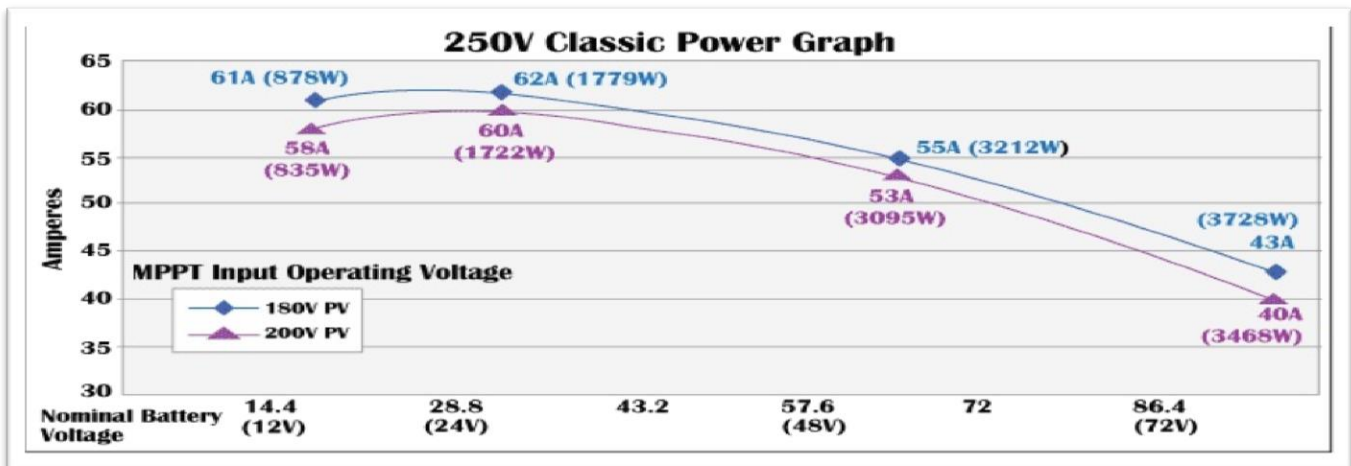

Table 3

The graphs above represent the max power output for a given input for each Classic. Using and understanding these power graphs will help maximize Classic's output power and aid in selecting wire and breaker/disconnects. Notice that lower battery voltages and lower PV input voltages result in higher continuous output power. The PV voltages listed are for reference and are not intended to be the only PV voltages supported. The battery voltages listed show the most used battery bank configurations. Other voltages are also supported. The Classic battery voltage parameters are fully user adjustable.

For example: if you are using a Classic 250 and 48v battery bank, the maximum continuous output power based on 25 degree C ambient is 55 amps when using a PV array that yields a Maximum Power Voltage of 180 volts. The same set up using a bit higher voltage modules that result in a 200V Maximum Power voltage will result in only 53 amps. Although 55 to 53 amps is not a significant change, it does give you the idea that all things being equal, lower voltages are a bit more efficient, keeping in mind that an MPPT controller needs to have the open circuit voltage of the array about 30% higher than the highest battery voltage you plan to charge to.

NOTE: You can find the Classic string sizing tool on the web page www.midnitesolar.com

NOTE:

A typical solar module around 250 watts will be a 60 cell module so it's open circuit voltage will be about 37 volts. So for a Classic 150-SL you could put 3 in series, A Classic 200-SL you could put 4-5 in series and a Classic 250-SL you could put 5-6 in series. PLEASE NOTE this is not intended to be a sizing tool but a general guide. Please follow the link above and size your array properly.

WARNING:

***VOC is a term you will hear a lot it stands for Volts Open Circuit, This is what is used to determine how many modules can go in series. VOC will be printed on the actual solar panel as well as on the spec sheet for the solar panel (For questions on the values found on the solar panel please consult the panel manufacturer or the distributor)**

***NEVER connect any loads or other stuff to the PV input on the Classics (Or any charge controller)**

***Classics that have exceeded their HyperVOC voltage (safe voltage) will not be under warranty.**

***A Classic needs a MINIMUM Input voltage to turn on. To calculate this take the highest voltage the battery will be at and multiply it by 1.33 if the PV input voltage is lower than that value the Classic will not come out of resting.**

Unpacking the Classic SL

When you receive your Classic you will want to unpack it and make sure everything is there and in good shape. Refer to Figure 1 Included in the Classic package should be:

- *Classic charge controller
- *Knock out covers 3 screened
- *Parts bag with stickers, Terminal block cover and silicone grease
- *User's manual printed

Email customerservice@midnitesolar.com for more information or if anything is missing or damaged.



Figure 1

Removing and installing the front cover on the Classic SL

Removing the front art deco cover is required to gain access to the wiring compartment.

Be aware if this is not the first removal of this cover there is a cable connecting the cover to the electronics. Do not pull hard or fast as damage could occur.

To remove the front cover of the Classic in preparation for installation, remove the 4 Phillips head screws with a #2 Phillips screwdriver. Lift the front half of the Classic casting off. You will need to unplug the display cable. It works the same as any phone cable.

When installing the cover for the final time, squeeze a small amount of Silicone grease (Included in the parts bag) onto the metal pins of the male jacks on the Display cable before plugging them in.

To re-install the front cover of the Classic you will need to plug in the display cable and carefully route it around the components on the circuit board as you set the cover in place. See Figure 2 Do not force the cover if it does not seat into place easily stop and look for any cables or wires that may be interfering. With the cover seated in place install the four Phillips screws with a #2 Phillips screwdriver.



Figure 2

Mounting the Classic SL

The following section covers typical mounting arrangements. If you require additional details that are not covered here please contact our technical support team. The Classic is designed to be directly mounted onto the MidNite Solar E-Panel. The Classic can also accommodate other installation methods as well. Mount in an upright position out of direct sunlight when possible. For your convenience the Classic has four one inch knock outs that are pre cast. The Classic has mounting locations and conduit locations that are similar to other brands of charge controllers to facilitate ease of upgrading older technologies.

Mounting the Classic directly to the E Panel:

- *Remove the front cover of the Classic.
- *Install the mounting bracket on the E Panel and start the upper mounting screw into the bracket, leaving it about half way out so you can hang the Classic on this screw.
- *Install the 1 inch close nipple into the E Panel as shown in the E-Panel directions. The 1" close nipple, 3 locknuts and 2 plastic bushings are included with each E-Panel. One locknut acts as a spacer.
- *Carefully hang the Classic on the screw in the bracket and slide it over the close nipple (see figure 4).
- *Install the lock nut and bushing on the close nipple and tighten the screw in the mounting bracket.
- *Don't install the front cover until you complete the wiring of the Classic.

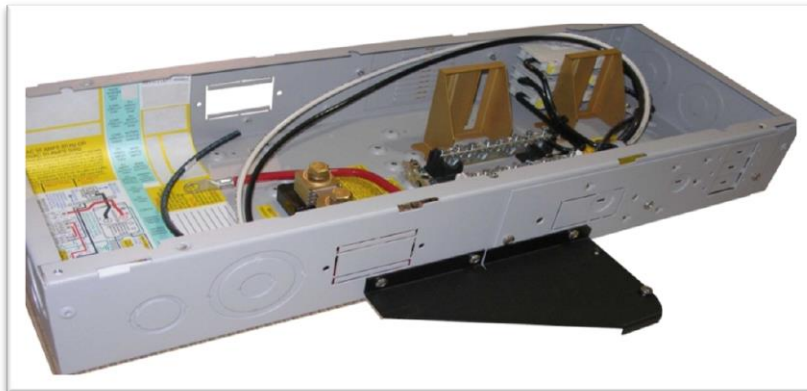

Figure 3 A Charge controller bracket mounted to the E-Panel. The bracket comes with every E-Panel

Figure 3

Classic Mounted to side of E-Panel



Figure 4

Nipple, locknuts and bushings that come with every E-Panel



Figure 5

Classic mounted to the side of a MidNite Solar E-Panel

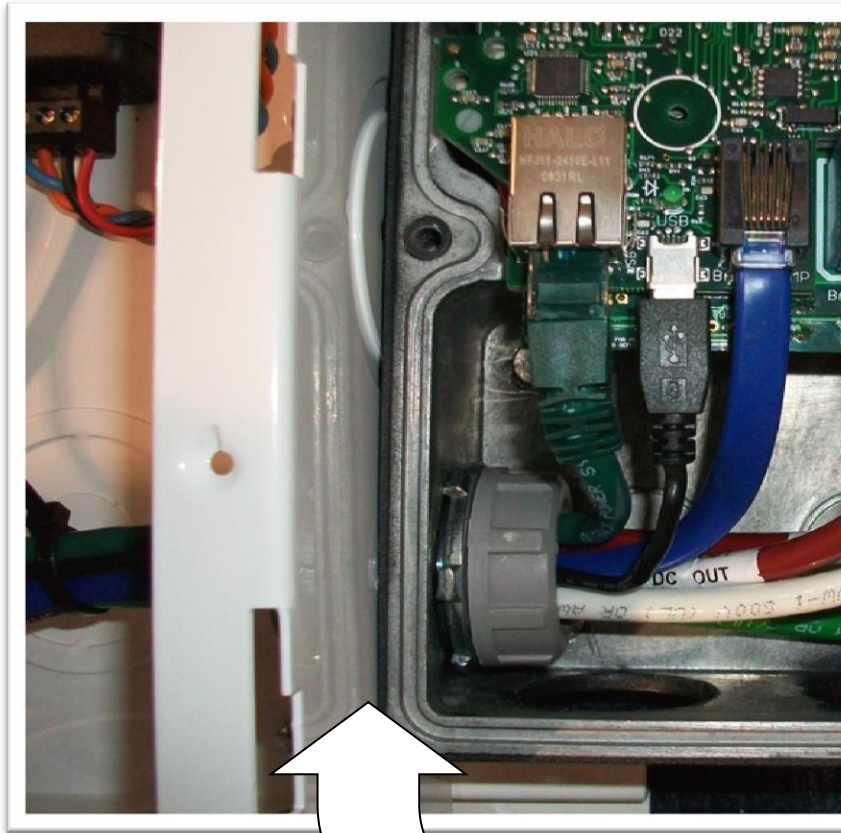
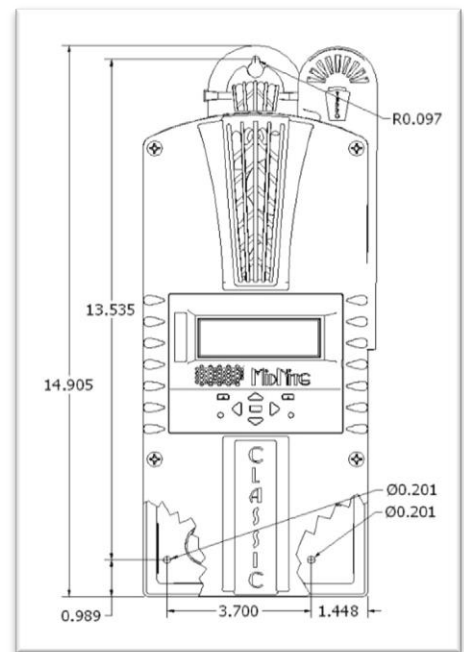

Figure 6

Install

locknut here to act as a spacer.

CLASSIC SL does NOT have Ethernet or USB!



Wiring the Classic SL



WARNING: Shock hazard. Disconnect the batteries and input power before opening the Classic front cover. ALWAYS use proper Over current devices and disconnects on the PV+ and Battery + at the Classic (MidNite DC breakers work well for both).

WARNING to comply with Australian/New Zealand code:
Any connection to the Classic SL will require double/reinforced insulated wire.

The Battery circuits are not isolated from hazardous PV circuits so proper cover/barrier must be in place to ensure user cannot access battery circuits without a tool.

The Classic SL should be wired by a qualified professional and needs to meet all applicable electrical codes.

Always make sure all source and battery circuits are de-energized and wait 5 minutes before working on the wiring in the Classic. The Classic has 2 common neutral (negative) terminals. Therefore, only one neutral conductor is required to run from the E-Panel and terminate on either (or both) common neutral terminal. This negative conductor should be sized to match the battery + cable. The Positive DC source wire goes to the PV+ Turbine+ screw. The Positive Battery DC wire goes to battery + terminal. Torque the terminal screws to the specs below.

To connect the wiring to the Classic:

- ❖ Ensure the DC source and Battery are disconnected
- ❖ Connect a grounding conductor between the Classic and system ground
- ❖ Ensure the breaker between the battery and Classic meets UL489 standards.
- ❖ Ensure the breaker between the DC source and Classic meets UL1077 standards.
- ❖ Connect the DC source and Battery wire to the Classic
- ❖ Connect any communications cables or auxiliary input/output wires
- ❖ Torque terminal connector screws to the following specs

The Torque specs on the DC terminal connector (big blue terminal connector) are:

- ❖ Up to #10 AWG torque to 25-35 inch pounds.
- ❖ #8 AWG torque to 30-40 inch pounds.
- ❖ #6 AWG or above. Torque to 40-50 inch pounds.

HyperVOC™

HyperVOC is a unique feature the Classic has built in. HyperVOC refers to when the DC Input Voltage raises above the maximum operating voltage (150V, 200V, 250V, depending on the Classic model). HyperVOC gives you the flexibility to go up to the maximum operating voltage PLUS the nominal battery voltage. For example, the Classic 150 has an input voltage rating of 150 operating volts, if the Classic 150 is connected to a 48 volt battery bank, the HyperVOC voltage limit will be: 150V + 48V a total of 198 Volts that the Classic can withstand without damage. When the Classic input voltage rises above 150 volts it will switch off (stop outputting power). As long as the Classic is in HyperVOC mode, the microprocessor and all other functions like AUX will continue running. When the input voltage comes back down below 150v (or the rated operating voltage of the Classic, depending on model) the Classic will wake up and start charging again automatically. This could happen in a really cold morning with a system that has a Voltage Open Circuit (VOC) close to the maximum operating input voltage.

*Note 1. A **HyperVOC** message will be displayed on the bottom right side of the Status screen.*

Note 2. Max nominal battery voltage to be added is 48v

Diagram 1 Explanations

- 10 = Solar Modules (PV)
- 11 = DC Combiner (Like our MNPV6 or MNPV12 for example)
- 12 = MNSPD300-DC (Surge protection)
- 13 = MNSPD300-AC (Surge protection)
- 14 = MNSPD300-DC (Surge protection)
- 15 = DC breaker for the Inverter (Also serves as a disconnect for the Inverter)
- 16 = DC breaker for the PV into the Classic (Also serves as a disconnect for the Classic)
- 17 = DC breaker for the Battery into the Classic (Also serves as a disconnect for the Classic)
- 18 = AC L1 Input Bus Bar. (This is where the generator L1 input gets wired)
- 19 = AC Neutral Bus Bar. (This is where ALL AC Neutrals get wired)
- 20 = AC L1 Output Bus Bar. (This is where the L1 Output to the Load center for the building would connect)
- 21 = Battery Positive Bus Bar. (This is where we would wire the Battery positive side of the Classic, as well as where we would wire up DC loads. Do NOT wire the battery cable to this bus bar).
- 22 = Earth Ground Bus Bar. (This is the common Earth Ground bus bar where all the grounds get wired back to and it needs to be connected to the building's ground rod system)
- 23 = PV Positive Bus Bar. (This is where the Solar Panels positive lead connects.)
- 24 = Battery negative Bus Bar. This is where the solar panel negative lead would go as well as the Classics negative lead and any negatives from the loads. Do NOT connect the battery negative cable to this bus bar
- 25 = DC Shunt. (The Shunt measures the amperage in or out of the battery. You connect the battery to one side and everything else to the other side.)
- 26 = Earth Ground system of the building
- 27 = Classic Charge controller.
- 28 = AC Generator
- 29 = Batteries. (The Voltage must match the voltage of the inverter. Typically 2-3 strings of batteries would be considered the max.)
- 30 = Optional Battery temperature sensor. (This is used to compensate for the temperature of the battery. If a battery is cold it has to be charged to a slightly higher voltage and when it is hot it will be charged to a slightly lower voltage.)
- 31 = DC Cables to Inverter

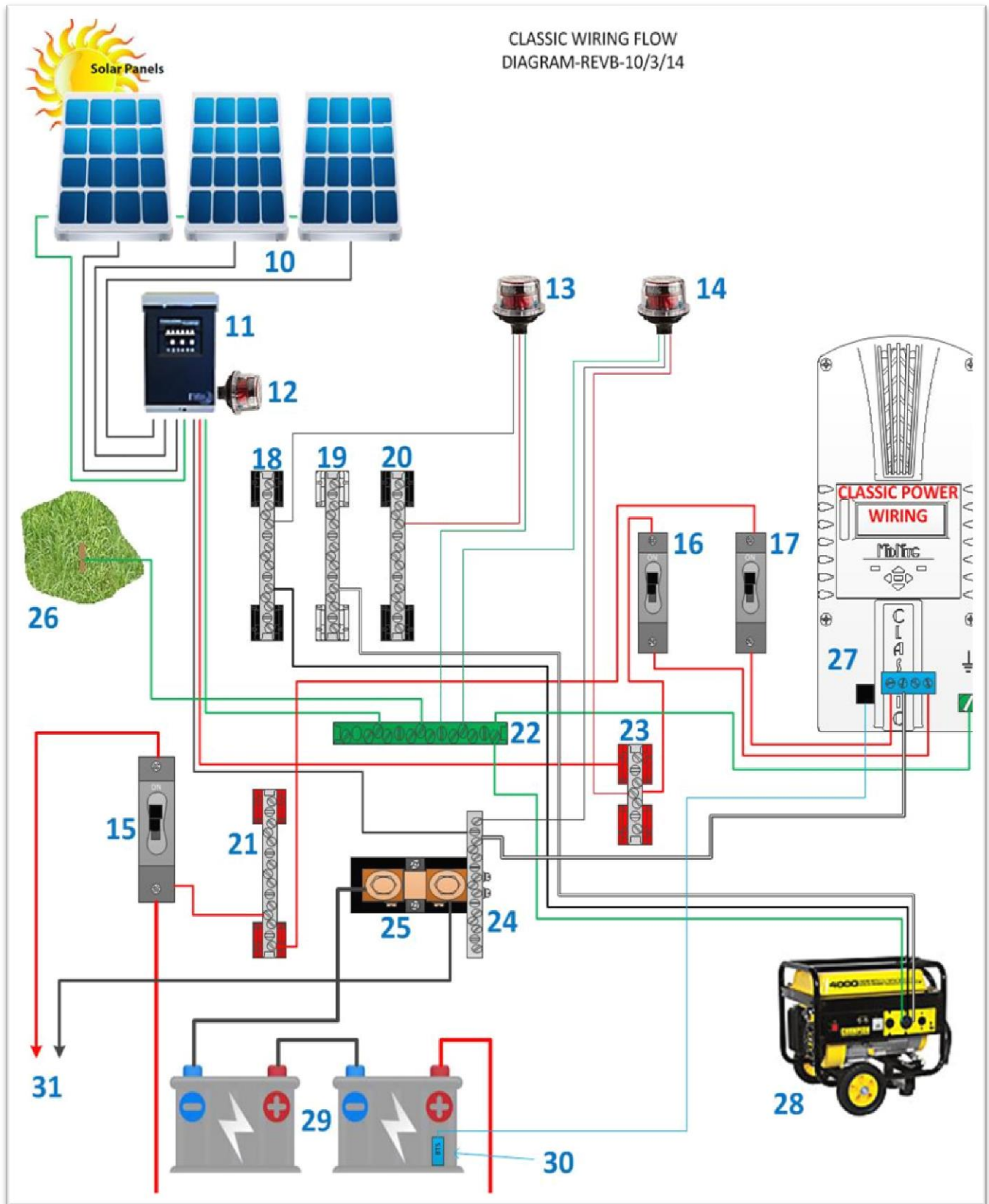

Diagram 1

DC Terminal Connector



Figure 7

The Classic's DC terminal connector is located on the circuit board as shown in figure 17. The connector will take up to a #4 AWG. #4 AWG THHN when installed in the Classic and MidNite E-Panel is rated for over 100 amps and is therefore suitable for the highest power available from the Classic 150-SL. After installing the wires for the last time snap in the blue cover that is included in the parts bag.

Maximum and Minimum Wire Size

The Classic's Blue DC terminal connector will accept wire from #14-#4 AWG

The Classic's Aux 1 and 2 terminal connector will accept wire up to #18 AWG

WARNING: Extra fine Stranded wire is actually larger in diameter than standard stranded wire like THHN therefore #4 extra fine strand (Welding cable) will not fit in the terminal block.

Over Current Protection and Wire Size Requirements

The over current devices, wiring, and installation methods used must conform to all electrical codes applicable to the location of installation. Wiring needs to be protected with proper strain relief clamps and or conduit. See page 49 for a breaker and wire size chart.

The USB cable, BTS cable and auxiliary input/output cables should run in a different conduit to preserve their signal. When installing the Classic in a MidNite E-Panel, it is acceptable to run all wiring through the same knockout hole. It is legal to run signal and power wires together as long as all wiring is listed for the highest voltage to be encountered. (Follow all local code)

Current Rating

The Classic limits the output current based on the model you have.

The Classic current ratings are:

Classic 150-SL - 96 amps maximum

Classic 200-SL - 79 amps maximum

Classic 250-SL - 62 amps maximum

Over Current Protection

The Classic must have over current protection to protect wiring from over current events. A means of disconnect must be installed on the DC in and DC out of the Classic. Consult your local codes to determine over current ratings. The breaker between the battery bank and the Classic must conform to UL489. The breaker between the DC source and the Classic must conform to UL1077 or UL489. The NEC requires 1.56 times short circuit current for PV over current protection. This is reduced to 1.25 times when using a breaker rated for continuous duty. All MidNite Solar breakers are hydraulic/magnetic and are rated for continuous duty (100% rating). No de-rating is required for the output breaker when using MidNite Solar breakers.

PV in particular will be capable of producing more current than its name plate rating in extreme situations, so the safe minimum wire size should be selected for the PV array maximum short circuit current. Please consult PV manufacturer for specifications. The US National Electrical Code requires 1.56 times the PV short circuit current for wire size on the PV input. Output wire size follows the NEC guidelines. Typical wire size for output is 6AWG for the Classic 250-SL and 4AWG for the Classic 200-SL and 150-SL but check all de-ratings for your wire type and installation method.

Long Distance Wire Runs

The Classic offers some unique opportunities if you are faced with longer than normal wire runs between the DC source and the Classic. The Classic comes in 3 input voltage ranges letting you design a DC source at a higher voltage if it is beneficial. For example, let's say you have a 300 ft run from a PV array to the Classic. You could wire for an open circuit voltage close to 250vdc accounting for the coldest temperature you will encounter. This will allow you to run a smaller gauge wire than with a lower voltage charge controller. The efficiency of a high voltage Classic is less than the lower voltage versions, so you need to weigh the benefit. If this sounds too complicated use this rule of thumb in selecting the proper Classic. PV runs up to 100 feet, use the Classic 150; runs up to 180 feet, use the Classic 200; or above 180 feet use the Classic 250.

If the wire size between the DC source and the Classic is larger than the Classic's DC terminal connector you can use a splicer block or similar connector to reduce down to #4 AWG close to the Classic. The MidNite E-Panels are supplied with a PV input bus bar that accepts up to 2/0 wire

Battery Temperature Compensation

A remote battery temperature sensor (BTS) can be purchased separately. This sensor raises or lowers charge voltage based on temperature. Connect BTS to the BATT TEMP jack. (Refer to Battery Temperature Sensor Installation 20) The Battery temperature menu appears as **T-Comp** in the BATTERY MENU. In this menu you can change the voltage compensation as needed. If the BTS is disconnected or shorted the Classic will automatically default to 25C on the Battery temperature.

Battery Temperature Sensor Installation



CAUTION - To reduce risk of injury, charge only deep-cycle lead acid, lead antimony, lead calcium, gel cell or absorbed glass mat type rechargeable batteries. Other types of batteries may burst, causing personal injury and damage. Never charge a frozen battery.



WARNING: RISK OF INJURY. To reduce the risk of injury, charge only properly rated (such as 6 V 12 V and 24 V) lead-acid (GEL, AGM, Flooded, or Nickel Cadmium) rechargeable batteries. Other battery types may burst, causing personal injury and damage.



WARNING: Explosion hazard during equalization, the battery generates explosive gases. Follow all the battery safety precautions listed in this guide. Ventilate the area around the battery using ventilators with brushless motors thoroughly and ensure that there are no sources of flame or sparks in the vicinity.

An optional Battery temperature sensor is available which plugs into the jack beside the DC Terminal connector labeled “Batt Temp”. Route the cable through the E-panel into the battery box. Pick a battery in the middle of the bank and about half way up the side of the battery thoroughly clean a spot off on the case. Then remove the protective tape from the sensor and adhere the temperature sensor to the battery. Some manufacturers use a double wall case on the battery. For mounting a temp sensor to a double wall battery case please refer to the battery manufacturer's recommended procedure.

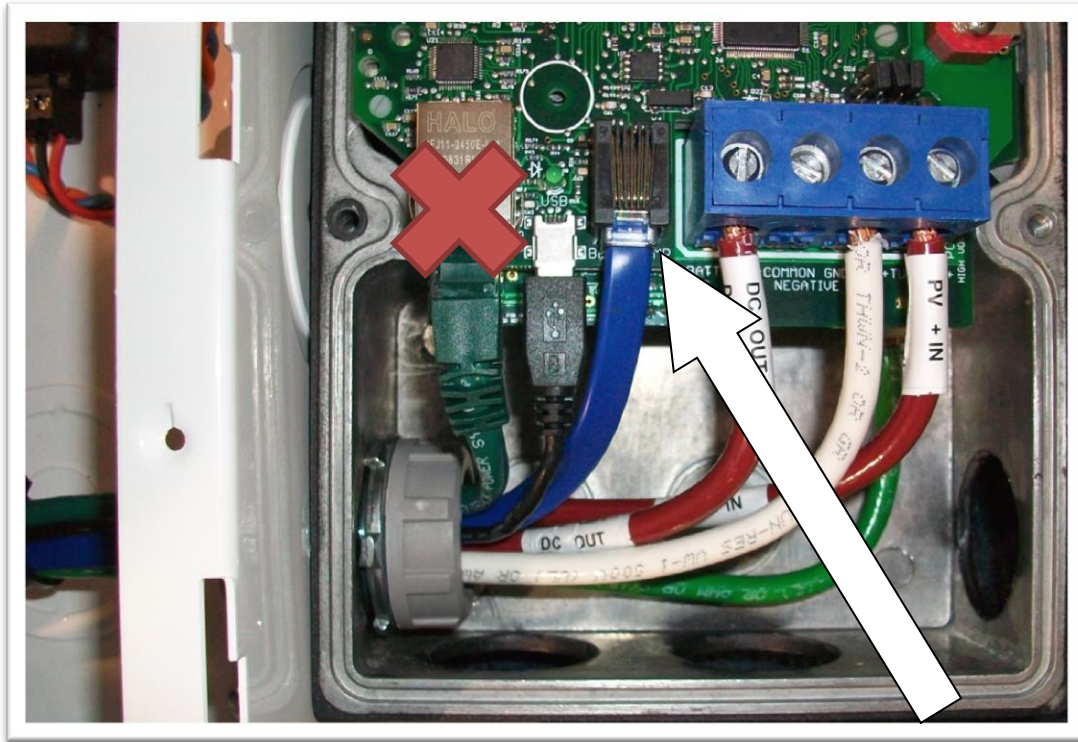

Figure 8

Insert BTS to the jack labeled BATTERY TEMP on the control board.

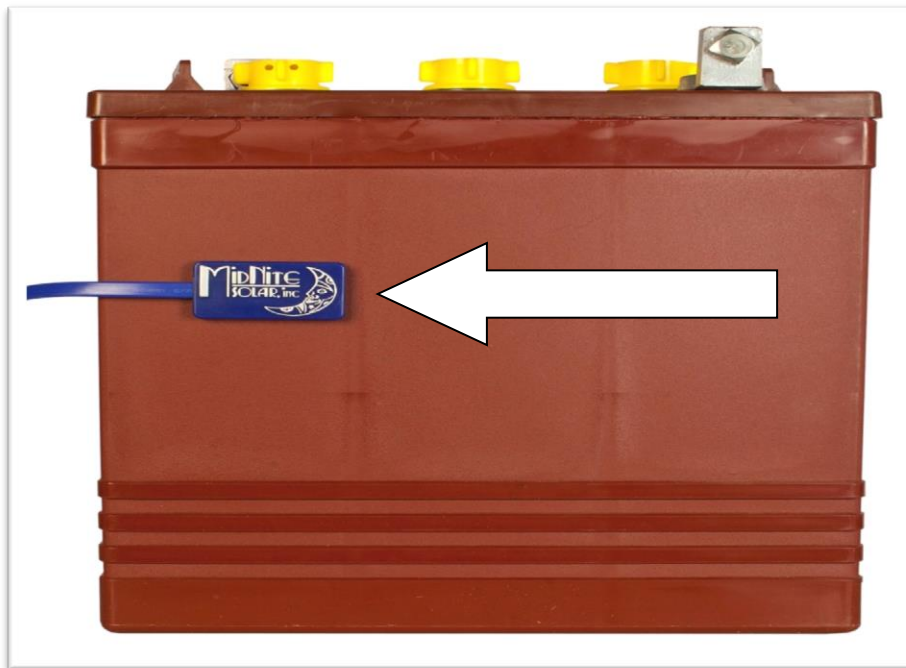

Figure 9

Chassis Grounding

In all installations the Classic chassis should be connected to ground. For systems with a battery breaker sized 60 amps and smaller, 10 AWG (6 mm²) copper is generally sufficient. For systems with a battery breaker sized 100 amps and smaller, 8 AWG (10 mm²) copper is required. For grounding conductor requirements on your specific installation please consult your local electrical code. **The chassis grounding terminal is in the upper right corner of the electrical connection compartment.**

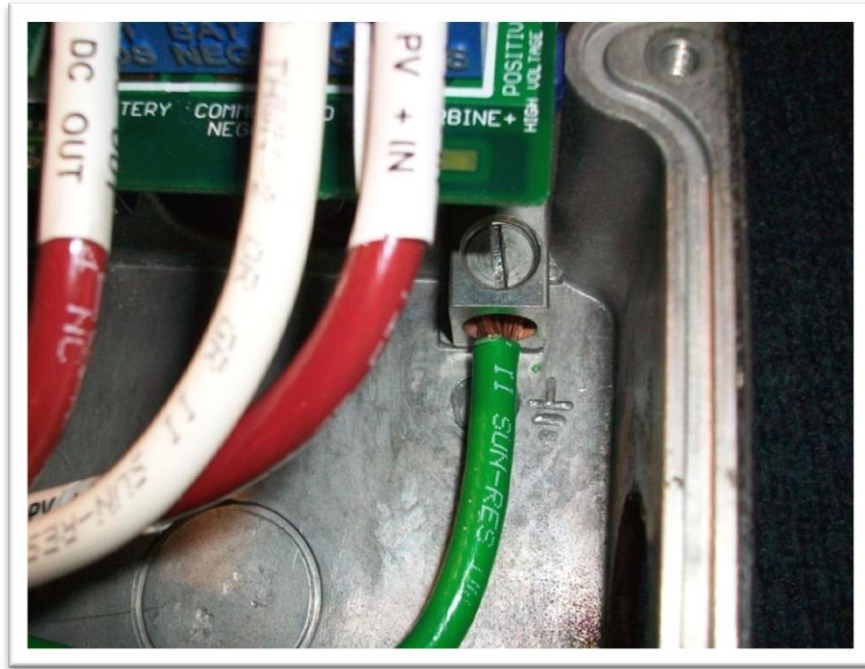

Figure 10

DC System Grounding

The Classic charge controller is designed to work with Negative Ground, Positive Ground or Ungrounded power systems. In grounded systems, dc negative may be connected to ground either externally or by using the Classic's internal grounding jumper, shown on figure 11 on Page 22. The internal grounding jumper should only be installed when the Classic's GFP is enabled.

In Positive ground or Ungrounded systems the GFP jumper must be removed. See Figure 15 Also note that with Positive ground there will be items still referenced to battery negative that can complete a short circuit of the battery bank, these items include, but are not limited to, the USB Cable and RS232 serial data lines.

DC GFP (Ground Fault Protection)

The Classic has internal ground fault protection (GFP) built in. Since 2008, the NEC requires a DC-GFP on all PV systems in the USA. The built in DC-GFP eliminates the need to purchase and install an external DC-GFP. If the internal grounding jumper is installed in a Classic, the battery negative and DC source negative must not be connected to the system grounding conductor anywhere in the system. Grounding of these circuits will defeat the GFP function. In a network with multiple Classics connected in Follow Me, only one Classic should have its internal grounding jumper installed and all should have GFP enabled. The factory setting will make a DC negative to System Ground connection in the Classic charge controller. The GFP function will need to be disabled for Positive ground or an ungrounded DC system.

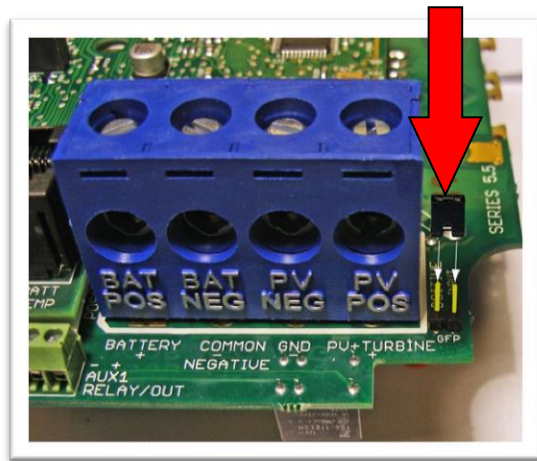

Figure 11



Figure 12

The Ground fault device is simple to understand and use. It detects a fault between battery/PV negative and earth ground just like the breaker DC-GFP system. The difference with the Classic is that it turns off the charge ability and sounds a loud warning when a ground fault is detected. The Classic's system consists of a PTC that is between the Negative and Ground internally in the Classic. A PTC is basically a self-healing fuse that will open when current exceeds its rating and reclose when current is dropped below its rating. The Classic will monitor this PTC and disable the charging when it senses it go open. When the fault is cleared the Classic will restore charging.

To disable the internal Ground Fault Protection function, the jumper labeled GFP needs to be removed and the GFP function needs to be disabled in the TWEAKS menu. See "Disabling GFP" for instructions.

To reset the internal GFP function after detection has occurred: fix the actual ground fault, then turn OFF the Classic and turn it back ON. Do this by turning the external battery breaker to OFF position and then to ON position.

Disabling GFP

The GFP feature should only be disabled to operate the Classic in an ungrounded power system or in systems where GFP is not required.

- Press Main Menu
- Scroll to the right or left until TWEAKS is highlighted and press ENTER
- In TWEAKS press the right soft key to get to the MORE menu
- In MORE scroll until GFP is highlighted
- Use the up and down arrow keys to toggle between on and off
- Press ENTER to save

Commissioning the Classic SL (Quick Start)

The Classic will enter into the Quick Set screens upon initial power up. If the Classic does not enter into the quick set or you want to restore to Factory Default follow these steps to initiate a Quick Set.

- ❖ With the power off to the Classic Hold the left and right arrow buttons down.
- ❖ Turn the power on to the Classic and continue to hold the arrow buttons until the setup screen is displayed.
- ❖ Answer the questions on the next few screens to complete the Quick Set.

Equalization

To do a manual Equalization charge, go into the Charge menu and highlight “EQ” and press “Enter”. Now “EQ Stopped” will be highlighted. Scroll up to select “Eq Started”. Press the “Status” button to return to the home screen. To stop a manual EQ in progress simply reverse the steps above. A manual EQ when started will last for that day.

Battery Charge Stages and Meanings

Bulk MPPT

This stage of the Classic means that the Classic will be putting out as much current as it can to raise the battery voltage to the absorb voltage set point. This is also known as Constant Current Mode.

Absorb

This stage means that the Classic will maintain the Absorb set point voltage until the batteries are charged. This stage is terminated at the end of the Absorb time or the End Amps set point, whichever is reached first. At this stage the Classic is not putting out maximum current, as that would increase the battery voltage over the Absorb set point. This is also referred to as Constant Voltage Mode.

The absorb time is proportional to the bulk time (i.e. the time bulk takes to reach the absorb voltage). The battery is considered “full” at the end of the absorb charge cycle.

Float

A *Float* cycle follows after the *Absorb* cycle is completed; *Float* is displayed on the screen. Battery voltage is held at the float voltage set point.

Equalize

The Equalization function can be manually initiated or can be set up to Auto Equalize. The intent of an Equalization charge is to bring all battery cells to an equal voltage by a controller deliberate overcharge. The goal is to return each battery cell to its optimum condition through a series of voltage controlled chemical reactions inside the batteries.

Resting

“Resting” will show on the display when the Classic is not charging the batteries, this is typically due to low light. If the Classic is resting and should not be, make sure Aux2 is **not** set to a logic input that is forcing it into resting.

Mode is OFF

The Classic has a software “ON” and “OFF” feature. This software “Switch” basically turns the relay off, effectively disconnecting the input source so the Classic will not charge the battery. If you see “**Mode is Off**” in the bottom right corner of the display then the Mode may have been turned off. To turn the mode back “ON” push the Main Menu button several times until “Charge” is highlighted. Scroll to the right until “Mode” is highlighted and press “Enter”. On this screen “OFF” should be highlighted use the up or down arrow to change it to “ON” and press “Enter”. Press the Status button once to return to the main status screen.

Adjusting Absorb, Equalize and Float Voltages

The table below describes the default preset voltages for the different nominal battery voltages. This means that if you set the Classic from the QUICK START to a different battery voltage the Classic will take the default voltage set points. Note. If you manually adjust the absorb float or equalize voltage set points, and then nominal battery voltage is changed to a different nominal voltage, (e.g. from 24v to 12v or to 48v etc.), manual adjustments may be required.

Battery Voltage	12v	24v	36v	48v	60v	72v
Bulk MPPT	14.3v	28.6v	42.9v	57.2v	71.5v	85.8v
Float	13.6v	27.2v	40.8v	54.4v	68.0v	81.6v
Equalize	14.3	28.6v	42.9v	57.2v	71.5v	85.8v

Table 4

To adjust these voltage set points follow these steps.

Absorb, Equalize and Float voltages are fully adjustable. You will need to get the actual voltages from the

battery manufacturer. To adjust these voltages follow the steps below.

- ❖ Press Main Menu to enter the Main Menu
- ❖ Scroll right or left until Charge is highlighted and push the Enter button
- ❖ Highlight Volts and press the Enter button
- ❖ Use left and right arrow keys to highlight the set point voltage to adjust
- ❖ Use up and down arrow keys to lower or raise the voltage
- ❖ Press the Enter button to save the new voltages.

Current Limit

The Classic has a current limit component which interacts with the temperature of the charge controller. If the Classic is exposed to extremely hot ambient conditions the output current will be reduced automatically to keep the charge controller safe. If the orange LED comes on the MNGP, it means that the Classic is in current limit mode. If you believe the Classic is not hot and the orange LED is on, most likely the current limit set point is too low. To check this, follow steps below.

- Press Main Menu
- Highlight the CHARGE menu and press the Enter Button
- Scroll to LIMITS and press the Enter Button
- Press the right arrow key to highlight the “Out Amps” column
- Use the up and down arrow keys to change the current limit then press the Enter Button to save this data

Calibrating Battery and PV Voltage

To calibrate the Classic battery and PV voltage reading, you will need a Volt meter to check the actual battery bank voltage or input PV voltage. Using the volt meter measure the voltage on the DC terminal connector of the Classic (refer to Screenshot 1) compare this reading to the reading on the Status screen in the Classic (press Status if not in this screen). To adjust the reading of the Classic to the one in the volt meter follow these steps:

- ❖ Press Main Menu, scroll to TWEAKS and press Enter
- ❖ Highlight VBatt and use the up and down arrow keys to match both of the readings
- ❖ Press the Enter button to save

Note. Use the description below to help complete the calibration of the Classic voltages.
TWEAKS screen

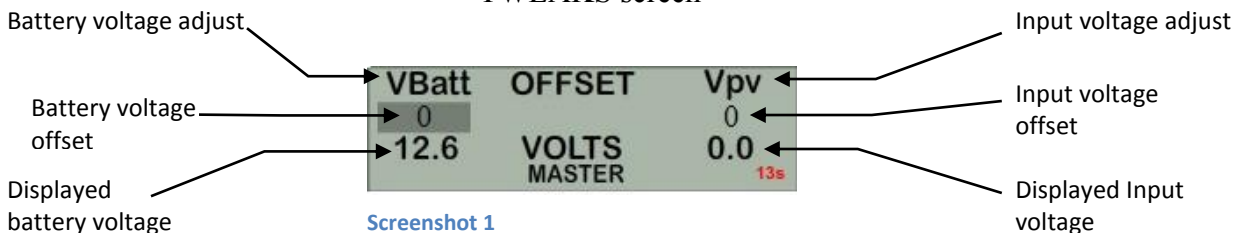

Configuring DC Input Source

To select the Mode the Classic will run in, follow the steps below.

- ❖ Push the Main Menu button.
- ❖ Scroll left or right until Mode is highlighted and then push the Enter button.

- ❖ Scroll to the right and highlight the current Mode than use the up and down arrows to set the mode you want.
- ❖ Take note of the Right soft key most modes have some set points that can be adjusted.
- ❖ Press the Main Menu button until you get back to the Mode Menu
- ❖ Set the ON/OFF to ON and press Enter

The following Modes will appear in this order in the MODE Menu.

Solar

This is the default mode for PV systems and has a very fast sweep (typically 1/2 second or less) that will re-sweep at user adjustable sweep intervals, unless the Classic finds that it needs to do a sweep on its own because of changing conditions. The timed sweep interval is user adjustable and is in units of minutes. SOLAR mode is typically best for PV systems, especially if there is partial shading at times during the day. SOLAR mode is best suited for shaded or un-shaded PV arrays that are at least one nominal voltage above the battery voltage. For severe partial shading or PV arrays with nominal voltage equal to battery voltage, you may also want to try Legacy P&O (Perturb and Observe) MPPT mode.

Legacy P&O

Legacy P&O (Perturb and Observe) mode is a slow tracking mode similar to the Micro Hydro mode but with the difference that it is slightly faster and will shut off if the power source goes off.

It has two settings that are user adjustable. Sweep Interval is the time between mini-sweeps, in minutes, and sweeps around the present (i.e. the last found) MPP Voltage. The range of this sweep is determined by the Sweep Depth user adjustment and is expressed as a percentage of Watts that the sweep started from. For example, if in Legacy P&O mode, the Classic was outputting 500 Watts and the Sweep Depth percentage was set for 10% (50 Watts), the sweep will bring the input voltage DOWN until the output power drops down to 450 Watts, then will sweep UP in voltage until the power drops again down to 450 Watts and then go back to the newly found MPP Voltage, waiting for the next sweep.

Note: Mode must be manually turned ON after changing the mode. To turn the mode ON highlight the OFF under ON/OFF and switch it to ON. Press enter to save this change.

Setting the Date and Time

To set the date and time manually on the Classic follow the steps below.

- ❖ Push the Main Menu button repeatedly until Charge is highlighted.
- ❖ Scroll left or right to highlight "MISC" and push the Enter button
- ❖ Scroll to "Time" and push Enter

Now scroll left or right to highlight the data you want to manually change. Use the up and down buttons to change the data. When you have all the data changed push the Enter button to save the changes.

The Classic includes a battery (CR1216) in the MNGP portion to keep the time running even when the power is disconnected. To replace the battery refer to the Installation Manual

Troubleshooting / FAQs

<p>How do I do a software Factory Restore on my Classic or Classic SL?</p>	<p>*Note this only works on the Classics with Displays not a Classic Lite with the MNLP (LED Panel) *Warning this will erase ALL settings. *Turn the PV breaker and Battery breaker off (What you don't have a breaker? Get one asap) and make sure the display has gone dark *Hold the left and right arrow and turn on JUST the battery breaker, Continue to hold the arrow buttons until you see the Quick Start pop up *Follow the on screen prompts to set up your controller.</p> <p>WARNING: You must get the battery charging voltages from the battery manufacturer and it is VERY important you do this and do not just leave it as default settings as it is likely this will undercharge and slowly destroy your batteries</p> <p>WARNING: The Clock is a 24 hr clock. Setting it off by 12hrs will cause it to reset to a new day at Noon.</p>
<p>How do I do a HARDWARE factory restore?</p>	<p>*Warning this will erase ALL settings. *Turn the PV breaker and Battery breaker off (What you don't have a breaker? Get one asap) and make sure the display has gone dark</p> <p>Do a hardware factory restore. There are 4 sets of jumpers directly above the blue terminal block. For the purpose of this we will call the left most jumper JP1 and the right most JP4 (actually labeled "Boot")</p> <ul style="list-style-type: none"> • Step 1- Turn the PV and Battery power off to the Classic and remove the front cover • Step 2- Locate the 2 jumpers JP1 and BOOT (JP4). Take the actual jumpers and keep them in your hand • Step 3- Turn the Battery power on to the classic • Step 4- within 1 minute place jumper JP4 on its two pins and then place jumper JP1 on its two pins. at this point the 3 leds on the top of the circuit board should flash back and forth for about 60 seconds. • Step 5- After the flashing stops power down the classic and remove JP1 and JP4 and stow them back on a single pin like they were. • Step 6- Put the front cover on and power up the Classic Lite. If you have the MNLP set to Custom you will need to go to the local app and reset the battery voltage and setpoints etc.
<p>What is a "VMM"?</p>	<p>*It has become industry slang for our factory restore "Vulcan Mind Meld" from the 2 fingers needed to push the arrows</p>

Classic will not power on. No Fans or life on power up.	<ul style="list-style-type: none"> *Check for reverse polarity on the Battery positive and negative terminals on the blue terminal block *Check for voltage on the Battery positive and negative terminals on the blue terminal block, if less than 10v charge the battery or find the bad connection
Classic Display is blank but the Classic is on	<ul style="list-style-type: none"> *Check that the blue display cable is plugged into the top jack on the main circuit board and the display *Try the middle jack on the circuit board *Try a different 4 conductor phone cable
Classic says "Resting" but the sun is out	<ul style="list-style-type: none"> *Resting indicates a lack of power available to the Classic. Verify you have voltage on the display under the "IN" that is at least 130% of the actual battery voltage at that time *Verify the charging mode is correct for the source as well as the "Mode" is on
Classic switches between Resting and Bulk MPPT repeatedly but produces 0 watts	<ul style="list-style-type: none"> *This can be normal under low light conditions. *Watch the input voltage, if it drops down close to battery voltage and then the Classic goes to Resting this is usually a sign of a bad connection. If it is rock solid call customer service *Try doing a factory restore. (Warning all settings will be lost)
The Display shows 0 volts in (or real close) but shows battery voltage correctly	<ul style="list-style-type: none"> *If this is a new install check for reverse polarity on the PV positive and negative on the blue terminal block inside the Classic *If the system has been running all along and this just happened call customer service.
The Display is showing all 0s and or "Got Comm"	<ul style="list-style-type: none"> *Make sure you did not put a different display on the Classic, Firmware must match on the Classic and MNGP. *Do a HARDWARE Factory Restore (See manual)
The Display is showing "Mode is OFF"	<ul style="list-style-type: none"> *Enter the main menu and select "Mode". Turn the Mode "ON" ad press Enter to save this. Then press Status to return to the main screen. *If using the Classic for wind and you cannot turn the mode on this can also indicate the wind curve is not linear and the classic cannot work with it. Please make sure the wind curve continually goes up hill.
Stuck in the Quick Start or "VMM"	<ul style="list-style-type: none"> *Check that the blue display cable is plugged in and connections are sound. Try unplugging it and plugging it back in. Check for corrosion also. *Do a HARDWARE Factory Restore (See manual)
The MNGP (Display) is fuzzy or has odd characters	<ul style="list-style-type: none"> *Check to make sure the blue display cable is plugged in well and that it is not running down over the 2 big yellow inductors on the left hand side of the circuit board.
Multiple charge controllers and one or more is showing 0 watts and absorb or float	<ul style="list-style-type: none"> *This is normal as the battery is almost full and the extra power is not needed so the controller throttles back to prevent over charging of the battery
Multiple Classics in Follow Me and they are not all making the same amount of power?	<ul style="list-style-type: none"> *This is normal as Follow Me simply coordinates the charge stages, each Classic still works independently as far as regulating the PV array.

<p>How do I verify Follow Me is working properly?</p>	<p>*You should first go to the Main menu and then into the “Temps” menu and verify all controllers are seeing the Battery Temp from the one with the BTS plugged in. *You should also see a blue LED flashing inside the top vent. There are two types of blink, A short blink that is about one tenth of a second means it is getting good information. A long blink that is about half a second indicates it did not get any info. If the blinks are ALL long then you probably have a bad cable and all cables should be checked immediately</p>
<p>The Fans seem way to loud</p>	<p>*If it is the internal fans make sure no wires or anything have come in contact with them inside the wiring compartment *If it is the external fan you may want to remove the front half of the “Turbo” plastic housing and make sure the fan is still adhered into the back plastic housing. If the fan has come loose a dab of silicone on each side should solve the noise issue. Please make sure not to get any silicone on the fan blades</p>
<p>Updating the firmware and the Classic went well but the MNGP will not update</p>	<p>*Make sure the MNGP (Display) is actually plugged in using the blue display cable in the top jack of the main circuit board *Verify you have an MNGP and not an MNLP. The MNLP is an LED panel that comes with the Classic Lite and does not need to be updated *When the black box pops up telling you to power the Classic up, Count to 4 before turning the breaker on *If you do not have a breaker or disconnect and you are trying to connect a wire to a terminal block or a battery the connection will likely be to dirty for the boot loader. Install the proper breakers</p>
<p>Classic goes to absorb at too low of a voltage</p>	<p>*Verify this is not normal operation do to the battery being warmer than the neutral point. You can verify the battery temperature by going into the main menu and selecting the “Temps” menu. The Classic like all other chargers will adjust the actual charge voltage based on the temperature of the battery. It uses 2 variables you program in for this. 1-Temperature neutral point (Typically 25 degrees C) and this is found in the WBjr set up menus. 2-Milli volts per degree C per cell (typically -5Mv). So verify both of these are set per the battery manufacturers specs. So for an example if Absorb was set for 58.8 volts and the battery is at 35 degrees C and the temp comp is set for -5mv we have a 10 degree C difference: $10 \times 24 = 240 \times 5 = 1200\text{Mv}$ or 1.2v so the Classic would actually charge to 57.6v</p>
<p>Classic goes to absorb at too high of a voltage</p>	<p>*Verify this is not normal operation do to the battery being cooler than the Neutral point. You can verify the battery temperature by going into the main menu and selecting the “Temps” menu. The Classic like all other chargers will adjust the actual charge voltage based on the temperature of the battery. See above calculation's the same works for cold batteries as well you just end up with a negative number so a battery that is 15 degrees C would look like: $-10 \times 24 = -240 \times 5 = -1200\text{Mv}$ or -1.2v so the Classic would actually charge to 60v</p>

<p>Classic goes to Float to early</p>	<p>*Make sure End Amps is not set to high causing the Classic to go to Float (End Amps is in the Charge menu and the way it works is if the charge current falls below the End Amps setting AND the Classic is in Absorb the Classic will go to Float. Setting End Amps to 0 will disable it. End Amps setting is a value the battery manufacturer supplies *Make sure you have the Absorb time is set properly</p>
<p>Follow Me with my Classic Lite is not working</p>	<p>*Classic Lites older than serial # CL05435 did not work with Follow Me please call customer service for a new MNLP *Verify you are seeing the short blips of the blue LED internally as talked about above. If not please check all your cables.</p>
<p>My Classic says "OCP is OFF" on the display</p>	<p>*This can happen on older Classics that have had the firmware updated. This will have no effect on the operation of the classic but to make the message go away do a factory restore to fix this. (Warning all settings will be lost)</p>
<p>My Classic says "OCP" now and then on the display</p>	<p>*This can be normal if the battery bank is small or the inverter cables are too small. If this shows up just once in a great while that would be ok but if it is happening pretty regularly you may want to look at the size of the battery cables, Age of the battery bank or the size of the battery. Call customer service for assistance</p>
<p>My Classic has an orange LED on the display lit up and or says "Amp Limit"</p>	<p>*This indicates the Classic is current limiting. Either because it has reached the current limit you have set in the Charge menu under limits or because it is too hot and it is backing its current down to prevent overheating. Go into the Main menu and the Charge category, Look in the Limits sub menu and verify the amp limits for In and Out are set to what you desire.</p>
<p>My Classic says "Hyper VOC" on the display</p>	<p>*This is indicating that the input voltage has exceeded the operational voltage of the Classic. If this is happening now and then on rare occasions when it is really cold then this is normal. If this is happening all the time this indicates the PV array was wired for too high a voltage, Please consult your installer for assistance with that</p>
<p>My Classic says "Battery over V" on the display</p>	<p>*This is an indication the Classic thinks the battery voltage is too high and has stopped charging. *This can happen with multiple controllers that are not networked together if one of the classics goes to float it can show this and will go away as soon as the other controller goes to float. *If this is a new install the wrong nominal voltage may be selected and a factory restore will be needed. *if this is a running system then you may have another charging source that has malfunctioned and over charging the battery bank</p>
<p>My Classic says "GRND FLT" on the display and is making a loud beeping</p>	<p>*Generally this would be caused by the PV or Battery positive shorting to ground somewhere in the system. The first thing to do is verify it is a real fault by carefully measuring between Battery Negative and Earth ground. If you see any voltage here then the system has a fault. Call your installer for help finding and rectifying the fault. The Classic will automatically stop showing the fault when the issue is fixed</p>

<p>My Classic says “Set date and time” on the display</p>	<ul style="list-style-type: none"> *Verify you are not setting the date and time with the local app without time sync off in the tweaks menu *If not using the local app to set the time then verify that time sync is ON in the tweaks menu. *Verify the “Remove” paper was removed out of the coin battery in the display. *Check coin battery for voltage, if under 2.5v replace the battery *Check the coin battery for glue residue from the remove tag *With coin battery removed press in on the 2 tabs to bend them in a little tighter and add more spring pressure to the battery.
<p>I have a WBjr and the SOC% is not showing on the main status screen</p>	<ul style="list-style-type: none"> *Verify the WBjr is set up properly by looking at the WBjr status screen and verifying the values it is showing look proper *The SOC% will not show up until the Classic with the WBjr goes to float once so it can calibrate. *If there are multiple Classics in Follow me we need to make sure the one with the WBjr is the first one to go to float. We recommend setting the Classics that do not have WBjrs for about 15 minutes longer on the absorb time this will ensure the Classic with the WBjr goes to float first. *If you are using End Amps make sure you use the Classic with the WBjr to do the sensing of End Amps.
<p>I don't see a WBjr status screen or I don't see all the settings shown in the manual?</p>	<p>*If the WBjr status menu is not present or does not match the manual then you most likely have older firmware. We recommend updating the firmware and doing a factory restore. (Warning all settings will be lost) The firmware can be found on our website under the “software” tab. Or at the URL below.</p> <p>http://www.midnitesolar.com/firmware.php?firmwareProduct_ID=1</p>
<p>My State of Charge seems inaccurate?</p>	<ul style="list-style-type: none"> *Verify the neutral temperature for the temp comp is set per the battery manufacturers specs (typically 25C) *Verify the Amp Hours of the battery bank is set properly (Note batteries in a string do not add in amp hours, so if you have a single string of 8 golf cart batteries each having 220AH then you have 220AH of capacity) *Verify the efficiency of the battery is set properly according to the battery manufacturer's specs (typically 94%)
<p>Classic says “Arc Fault” on the display and is making a loud beeping noise</p>	<ul style="list-style-type: none"> * This is generally indicating you have a bad connection somewhere causing arcs, This can be anywhere in the system so generally finding it is easier if you can turn things off and see what causes the Fault to clear. *This also can be caused by loads etc and be a nuisance trip. Please see the manual for help with that
<p>My Classic Lite has ALL of its LEDs blinking slowly</p>	<ul style="list-style-type: none"> *This is indicating the LED panel “MNLP” is not talking to the Classic, Try making sure the blue cable is plugged in well. *Try plugging the Blue cable into the middle jack *If both of the above fail do a HARDWARE factory restore (See manual)

<p>My Classic Lite has the left hand 3 LEDs blinking on the LED panel</p>	<p>*This indicates wrong code, If you recently updated code you may have updated with the wrong model code. Look at the inductor stickers they will have the model of classic on them also so you can verify and re update with that model code</p>
<p>When I make changes to my Classic Lite with the Local App they do not appear to stay</p>	<p>*This is generally caused by failing to put the MNLP (LED panel) into Custom mode. To put this into custom mode set S1 Switches 1 and 2 to ON or UP this will allow the LED panel to read the classic but not make ANY changes to its programming so you can program the Lite with the Local App</p>
<p>My Time gets out of whack on the Local App when the Classic Lite is powered down and back up</p>	<p>*Unfortunately on the Lite there is no battery to back up the real time clock like there is on the regular Classics, You will need to use the Local App to reset the time after a power cycle, The Local App will turn yellow if the time is not in sync with the PC you are viewing it on. And the Local app has a time sync button on the Basic Configuration tab</p>
<p>I am having trouble getting my Classic Lite on the network</p>	<p>*We recommend setting the dip switches for normal operation and DHCP. Connect to it with the Local App and verify it has connected to the network. Now at this point we can go switch the S1 switch 1 and 2 to ON or UP to set the MNLP to custom. Do this with the Classic Lite powered on. Now you can change the network settings on the Local App if you want.</p> <p>(Note setting switches to custom first and then powering the Classic Lite can cause issues trying to connect as it assumes you are already connected, We anticipate setting to Custom AFTER connecting to the network)</p>
<p>My Classic or Classic lite keeps going back to address 10 after I readdress it to something else</p>	<p>*There was a bug in older firmware that would cause this. We recommend updating the firmware and doing a factory restore. (Warning all settings will be lost) The firmware can be found on our website under the "software" tab. Or at the URL below.</p> <p>http://www.midnitesolar.com/firmware.php?firmwareProduct_ID=1</p>
<p>I am having issues connecting my Classic or Classic Lite directly to my PC without a Router</p>	<p>*We advise against this as it is more complicated than most people feel comfortable with. We recommend a cheap router for this as it makes it much easier. The way to think about this is the Computer and Classic have NO address until the Router addresses them so if we must go direct we have to address both of them.</p> <p>*To do a direct connection we recommend a cross over Ethernet cable. Then you need to set the Classic to a static IP say 192.168.1.5 then you need to go into the IPV4 properties on the PC and set it for a static IP also of say 192.168.1.2</p> <p>Note the important part here is that the first 3 sets of numbers match 192.168.1.xxx for example and that the LAST sets of numbers do NOT match as this is the unique identifier of where each item is. You will not need to worry about Gateways or DNS IPs for this connection. For more help with this see our video on direct connection to Classic or consult your network guru</p>

<p>I cannot find an uninstaller for the Midnite firmware updater?</p>	<p>*Go to the C directory and find the folder labeled midnitesolar and open it. In here you will find an uninstaller, simply double left click it to run it. After it is complete you can delete the midnitesolar folder to completely remove any files left behind</p>
<p>What is the PASSWORD for the Classic?</p>	<p>*All Classics use 142 for the password</p>
<p>I hear a singing sound coming from my Classic, Sort of a high pitched whine that varies</p>	<p>*This is the inductors “Singing” when the Input voltage is really low. This is normal and is no cause for concern, however if it bothers you then you can disable it by going to the main menu and entering into tweaks. Look for LoMax and set it to off and press enter. Note: If the PV array is real low voltage and its max power point is close to the battery voltage disabling LoMax will cause a slight loss in power as the Classic will not be able to track all the way to the battery voltage looking for the MPPT voltage</p>
<p>I have a classic that came with a grey “Magnum” Battery temp sensor can I replace it with a Midnite blue one?</p>	<p>*No the Magnum sensor was a different resistance value so those classics where modified to use those sensors. Call customer service if you need help with a new sensor</p>
<p>How can I verify that all my fans work on My Classic?</p>	<p>*If you unplug the battery temp sensor and use a flat bladed screw driver to short out all 6 pins inside the jack (Carefully so as not to bend the pins) the fans should all start spinning</p>
<p>How do I find the “Wizard”?</p>	<p>*You won't, we removed the wizard as it asked a lot of questions that did nothing and was confusing, We replaced it with the Quick Start that comes up when you first power the classic or do a factor restore</p>
<p>My fans run all the time no matter what the Classic is doing</p>	<p>*Check to make sure you did not pinch the Fan wire at the top in the casting</p>
<p>I remotely mounted my MNGP (display) and now it won't power on or it blinks but won't power up</p>	<p>*Check that you made the cable exactly the same as the blue one. Note that Pin one on one end becomes Pin 6 at the other end (Mirror image) *Try a heavier cable, We have found that off the shelf phone cables are good for about 25ft max before the voltage drop is to great. We have found that cable like Cat3 or Cat5E can go about 100ft no problem.</p>
<p>How many amps can my Classic handle on the input side? OR Can I put too much PV on my Classic?</p>	<p>*The Classic regulates very well so within reason there is no limit on the input amps or PV wattage. We recommend you not exceed 150% of the capacity. The Classic, just like a grid tie inverter, can be over driven on the pv side it simply produces the max amount it is rated for.</p>
<p>My Classic is not making the same amount of wattage as I have for Solar Panels?</p>	<p>*First it should be noted a solar panel is rated in a lab so in the real world we typically see about 80% of what it is labeled (So a 100 watt panel becomes an 80 watt panel) *Does the Classic say Absorb, Float or EQ? If so that means the battery is nearly full and the Classic is throttling back to prevent over charging the battery.</p>

My Label is gone or I mixed up my covers how do I know what model Classic I have?	*You can remove the cover and look at the stickers on the big yellow inductors on the left side of the circuit board *You can press the status button several times and the Classic will say "Connected to Classic xxx" on one of them, this is your model #
I can't read my serial # sticker how can I find my serial #	*Press the status button several times and a screen will come up saying "Connected to a Classic xxx" in the bottom right corner is the serial number, it will start with a CL.
How do I know what Nominal voltage my Classic is programmed for?	*Press the status button several times and a screen will come up saying "Connected to a Classic xxx" to the right of this it will say the battery voltage it is programmed to (Example 48v)
I have Aux1 programmed properly but I cannot get 12v out of it when I should?	*Most likely the Jumpers on the bottom left corner of the circuit board are set for a dry relay not for a 12v signal. See the Aux portion of the manual for help with that.
I was in the middle of a firmware update and the update got interrupted what do I do?	*No problem simply start over with the update, The Classic has a boot loader that will always look for new firmware on boot up so you can not damage the Classic.
Can I use wind and Solar on a single Classic?	*No they both require drastically different tracking algorithms so you will need two Classics
Can I have more than one Classic on a single battery?	*Yes as long as they have separate Solar Arrays
Do I have to shut off my Classic if I have a different charger charging?	*No the Classic will work just fine in conjunction with ANY other charger on the same battery

Table 5

Electrical Specifications

Model	Classic150-SL	Classic200-SL	Classic250-SL
Operating Volts in	150VDC	200VDC	250VDC
Max Hyper VOC	150+battery	200+battery	250+battery
*Battery Charge Volts	12-93 volts	12-93 volts	12-93 volts
**Absolute Current Output at 25°C	96a at 12v battery 94a at 24v battery 83a at 48v battery	74a at 12v battery 70a at 24v battery 65a at 48v battery	60a at 12v battery 62a at 24v battery 55a at 48v battery
De-rate current at 40°C+	80 amperes	66 amperes	52 amperes
Environment	-40c to 40c		
Dimensions of Classic	14.87"X 5.95"X 4.00" 378mm X 151mm X 102mm		
Dimensions of Box	19.00"X 8.50"X 5.70" 483mm X 216mm xX145mm		
Shipping Weight	11.5 lb 4.9 kg		
NOTE: Current output ratings were measured with 75% of the PV array's VOC (Open Circuit Voltage)			
*NOTE: Calculated by adding battery voltage to the maximum input operating voltage (48V battery max)			
**NOTE: Measurement Accuracies: +- 0.12v, offset calibration adjustment maybe necessary			

Table 6

Specifications Mechanical

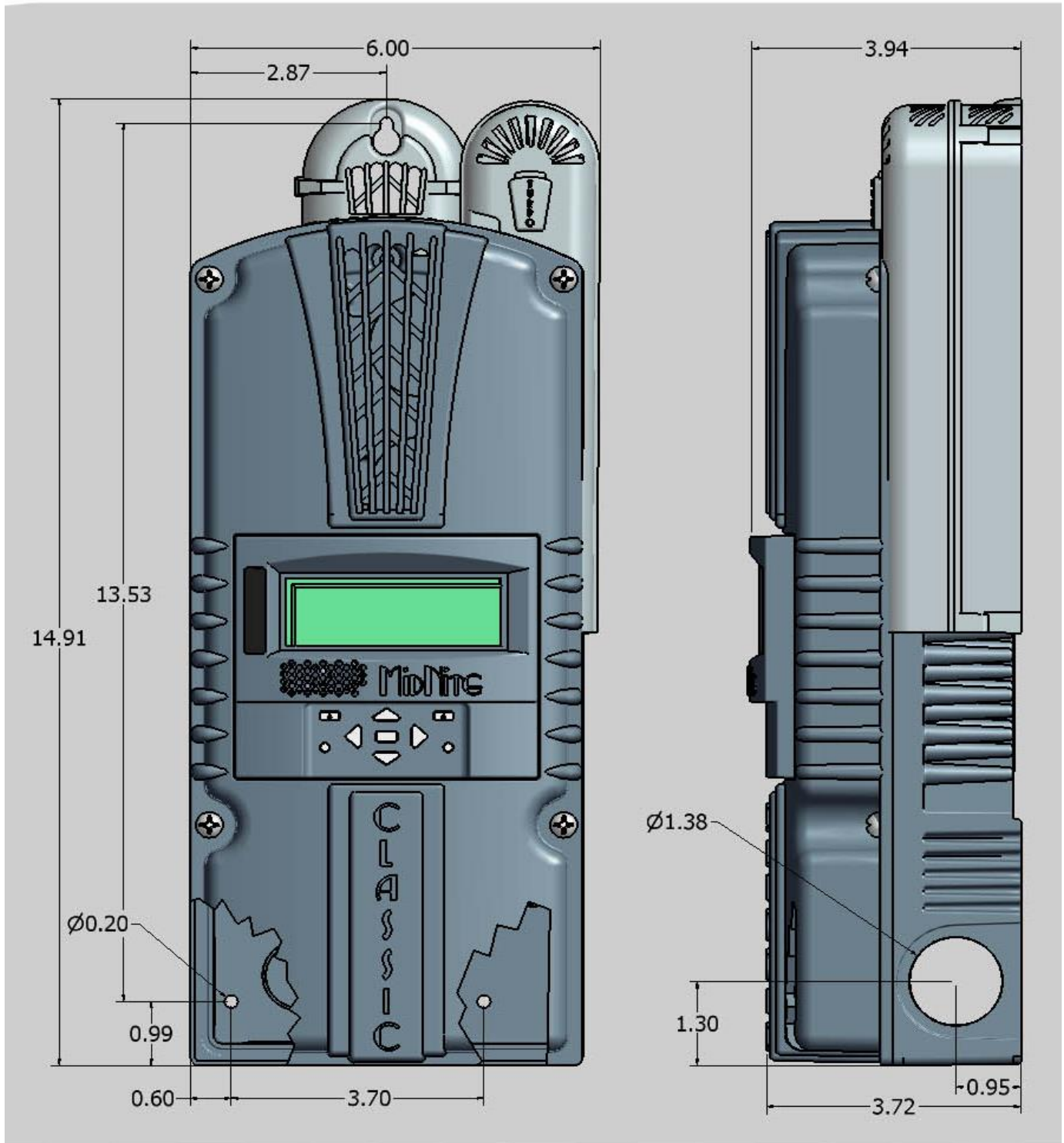

Figure 13

Classic Breaker sizing

Classic Breaker sizing

Model	Bat V	MPPT V (not VOC)	In/Out ratio	Max output A	Output brkr	Wire size 310-17*	Max input A	Input breaker/wire with 125% factor**
Classic 150	12	70	5.83	96	100	4AWG	16.46	30A /10AWG - 63A /6AWG 150V
Classic 150	24	70	2.92	94	100	4AWG	32.19	50A/8AWG - 63A/ 6AWG 150V
Classic 150	48	70	1.45	86	90-100	4AWG	59.31	80A/4AWG 150V
Classic 150	12	90	7.5	96	100	4AWG	12.8	30A /10AWG - 63A /6AWG 150V
Classic 150	24	90	3.75	94	100	4AWG	25.06	50A/8AWG - 63A/ 6AWG 150V
Classic 150	48	90	1.87	83	90-100	4AWG	44.38	63A 150V
Classic 150	12	100	8.33	92	100	4AWG	11.04	30A /10AWG - 63A /6AWG 150V
Classic 150	24	100	4.16	91	100	4AWG	21.87	30A /10AWG - 63A /6AWG 150V
Classic 150	48	100	2.08	80	80-90	4AWG	38.46	50A/8AWG - 63A/ 6AWG 150V
Classic 150	12	110	9.16	93	100	4AWG	10.15	30A /10AWG - 63A /6AWG 150V
Classic 150	24	110	4.58	84	90-100	4AWG	18.34	30A /10AWG - 63A /6AWG 150V
Classic 150	48	110	2.29	76	80-90	4AWG	33.18	50A/8AWG - 63A/ 6AWG 150V
Classic 150	12	120	10	92	100	4AWG	9.2	30A /10AWG - 63A /6AWG 150V
Classic 150	24	120	5	82	90-100	4AWG	16.4	30A /10AWG - 63A /6AWG 150V
Classic 150	48	120	2.5	76	80-90	4AWG	30.4	50A/8AWG - 63A/ 6AWG 150V
Classic 200	12	70	5.83	79	80-90	4AWG	13.55	30A/10AWG - 50A/6AWG or 8AWG 300V
Classic 200	24	70	2.91	78	80-90	4AWG	26.8	50A/6AWG or 8AWG 300V
Classic 200	48	70	1.46	76	80-90	4AWG	52.05	80A/4AWG 300V
Classic 200	12	120	10	77	80-90	4AWG	7.7	30A/10AWG - 50A/6AWG or 8AWG 300V
Classic 200	24	120	5	74	80-90	4AWG	14.8	30A/10AWG - 50A/6AWG or 8AWG 300V
Classic 200	48	120	2.5	70	70-80	4AWG	28	50a/6AWG or 8AWG 300V
Classic 200	72	120	1.66	65	70-80	4AWG	39.15	50a/6AWG or 8AWG 300V
Classic 200	12	140	11.66	74	80-90	4AWG	6.34	30A/10AWG - 50A/6AWG or 8AWG 300V
Classic 200	24	140	5.83	72	80-90	4AWG	12.34	30A/10AWG - 50A/6AWG or 8AWG 300V
Classic 200	48	140	2.92	65	70-80	4AWG	22.26	50a/6AWG or 8AWG 300V
Classic 200	72	140	1.94	63	63-70	6AWG	32.47	50A/6AWG or 8AWG 300V
Classic 200	12	160	13.33	73	80-90	4AWG	5.47	30A/10AWG - 50A/6AWG or 8AWG 300V
Classic 200	24	160	6.66	72	80-90	4AWG	10.81	30A/10AWG - 50A/6AWG or 8AWG 300V
Classic 200	48	160	3.33	65	70-80	4AWG	19.52	30A/10AWG - 50A/6AWG or 8AWG 300V
Classic 200	72	160	2.22	53	60-63	6AWG	23.87	50A/6AWG or 8AWG 300V
Classic 250	12	180	15	61	63-70	6AWG	4.06	30A/10AWG - 50A/6AWG or 8AWG 300V
Classic 250	24	180	7.5	62	63-70	6AWG	8.26	30A/10AWG - 50A/6AWG or 8AWG 300V
Classic 250	48	180	3.75	55	60-83	6-4AWG	14.66	30A/10AWG - 50A/6AWG or 8AWG 300V
Classic 250	72	180	2.5	43	50-63	6AWG	17.2	30A/10AWG - 50A/6AWG or 8AWG 300V
Classic 250	12	200	16.6	58	60-70	6AWG	3.49	30A/10AWG - 50A/6AWG or 8AWG 300V
Classic 250	24	200	8.33	60	60-70	6AWG	7.2	30A/10AWG - 50A/6AWG or 8AWG 300V
Classic 250	48	200	4.16	53	60-63	6AWG	12.74	30A/10AWG - 50A/6AWG or 8AWG 300V
Classic 250	72	200	2.77	40	40-63	8-6AWG	14.44	30A/10AWG - 50A/6AWG or 8AWG 300V

*NEC310-17 is the chart for single conductors in free air. This chart is conservatively based on this chart, 75C wire inside a MidNite E-Panel
 ** MidNite Solar breakers are all rated for 100% duty cycle and do not require 156% safety factor. * above also applies to input breaker and wire.

Table 7

CLASSIC SL MENU MAP
MidNite Solar Inc.

1 of 4

Classic SL Menu Items
Status, Charge, Mode, Aux, Misc, Logs, Tweaks and Temps

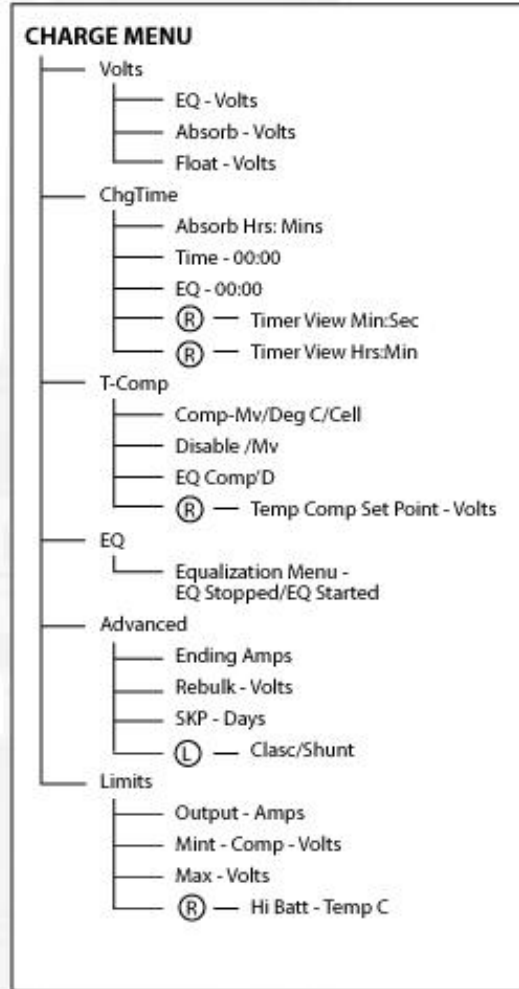
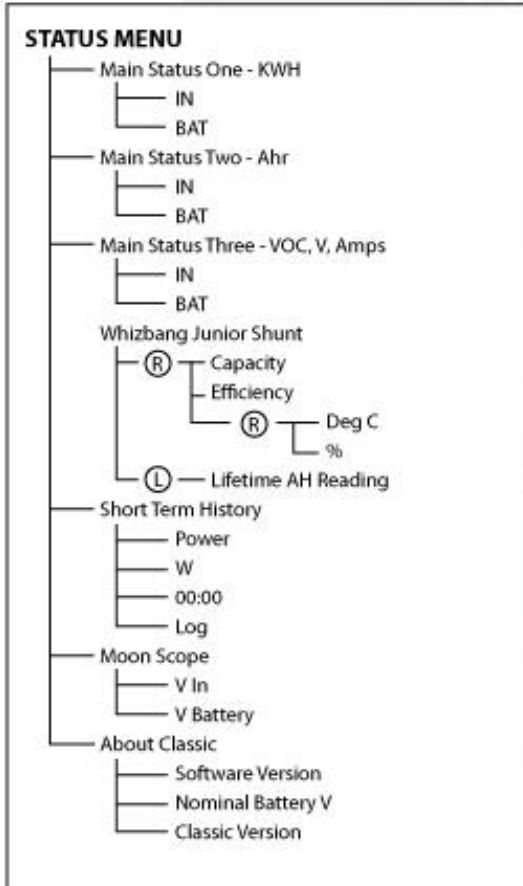

(R) Symbolizes pushing the Right Soft Key
(L) Symbolizes pushing the Left Soft Key

WARNING! The Classic's USB port is NOT isolated from battery negative. This is typically only an issue on positive ground systems or systems with a tripped ground fault protection device. Care must be taken that a computer connected to the Classic's USB port is either isolated from ground and the Classic's negative or that the computer's USB negative is common with the Classic's negative and ground.

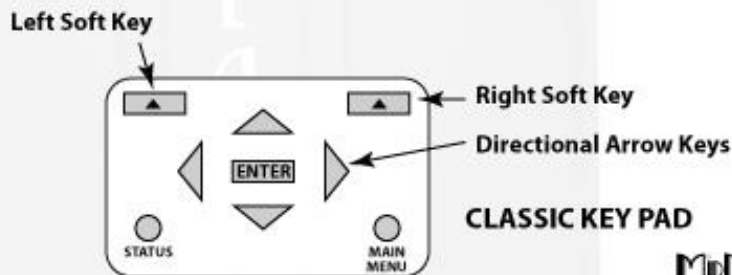

www.midnitesolar.com

17722 - 67th Ave NE Arlington, WA 98223 PH. 360-403-7207 Fax 360-691-6862



CLASSIC SL MENU MAP
MidNite Solar Inc.

2 of 4

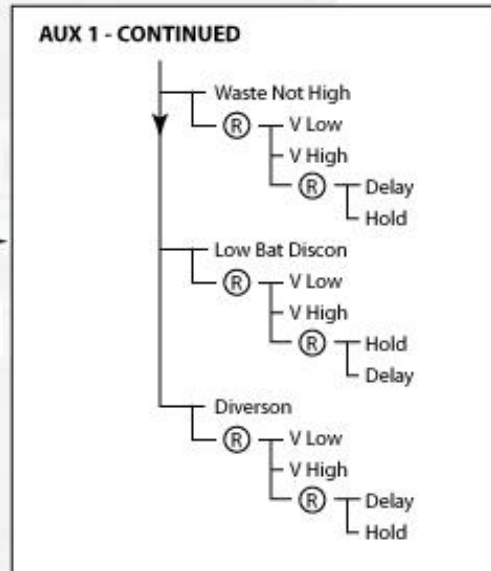
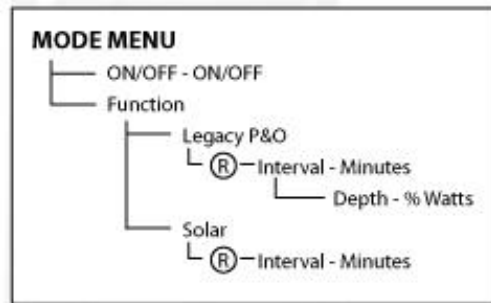
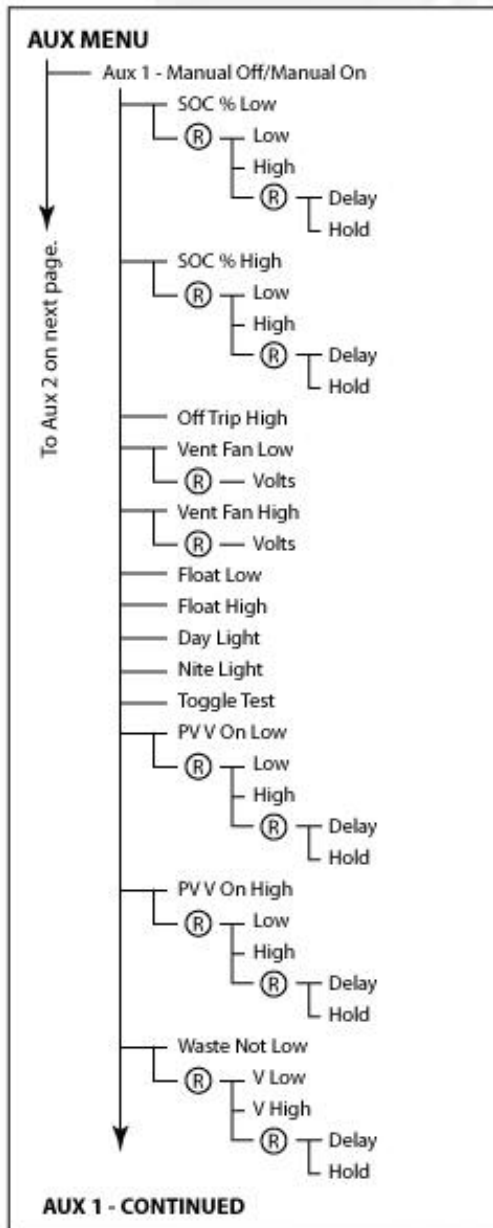

(R) Symbolizes pushing the Right Soft Key
(L) Symbolizes pushing the Left Soft Key



www.midnitesolar.com

17722 - 67th Ave NE Arlington, WA 98223 PH. 360-403-7207 Fax 360-691-6862

CLASSIC SL MENU MAP
MidNite Solar Inc.

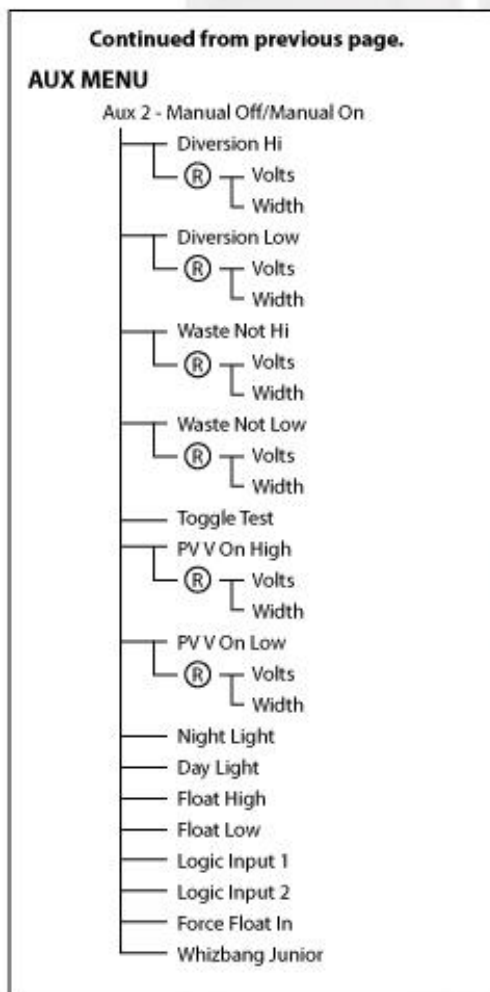

(R) Symbolizes pushing the Right Soft Key

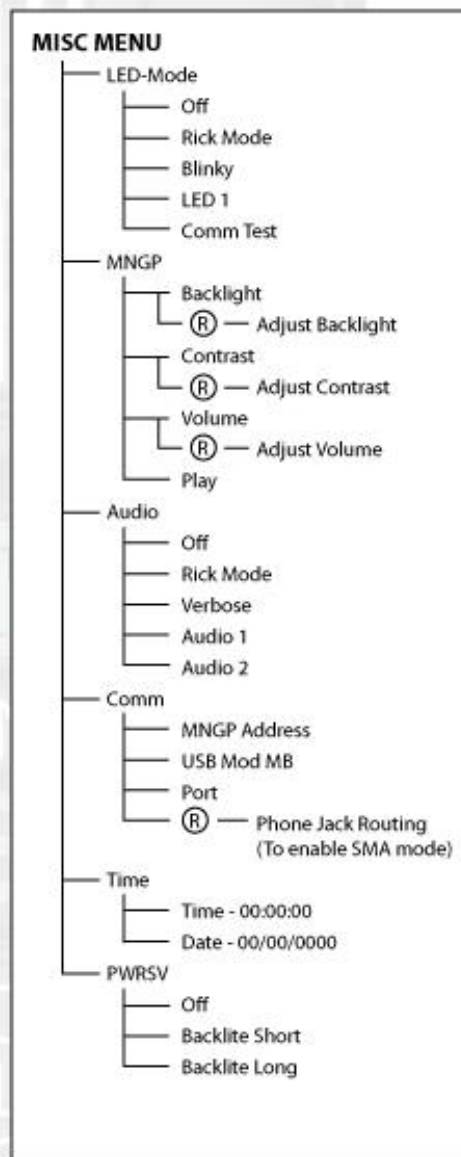

www.midnitesolar.com

17722 - 67th Ave NE Arlington, WA 98223 PH. 360-403-7207 Fax 360-691-6862

CLASSIC SL MENU MAP
MidNite Solar Inc.

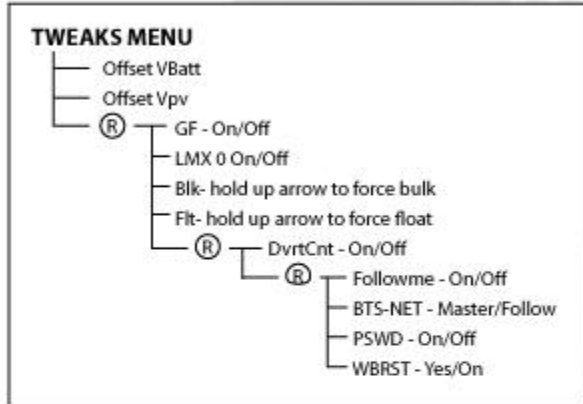

(R) Symbolizes pushing the Right Soft Key
(L) Symbolizes pushing the Left Soft Key

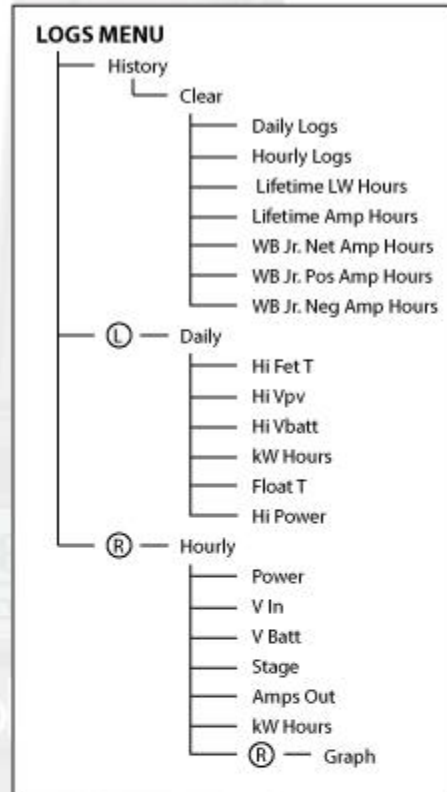

www.midnitesolar.com

17722 - 67th Ave NE Arlington, WA 98223 PH. 360-403-7207 Fax 360-691-6862

Table 8

Glossary of Terms

Absorb – Constant voltage charge stage to fill the batteries. The controller is regulating so maximum power will not be seen at this time. The Absorb timer is also counting down to the switch to Float.

Aux – Auxiliary relays. The Classic has 2 relays: Aux 1 can be configured as a 12 volt signal or a dry relay, Aux 2 can be used as a PWM signal output.

BLK – Bulk MPPT Mode. By using the up arrow in Tweaks under BLK you can force the Classic into Bulk mode.

Bulk MPPT - Maximum current charge stage, the Classic is trying to bring the batteries to the Absorb voltage set point. We are basically putting all available power into the batteries.

Comm – This menu allows adjustment of things like Mod Bus port, USB Mode and MNGP address.

DvrtCnt – When enabled, allows the charge stage timers to continue to run when the diversion modes are holding the battery voltage just below the actual set point.

Equalize - Constant voltage charge stage to equalize the batteries. The controller is regulating so maximum power will not be seen at this time. The Equalize timer is also counting down to the switch to Float.

EQ MPPT - Maximum current charge stage. The Classic is trying to bring the batteries to the Equalize voltage set point. We are basically putting all available power into the batteries.

Float – Constant voltage charge stage with a lower voltage than the Absorb charge point. The controller is regulating so maximum power will not be seen at this time.

Float MPPT – Maximum current charge stage. The Classic is trying to bring the batteries to the Float voltage set point. We are basically putting all available power into the batteries.

FLT – Float mode. By using the up arrow in Tweaks under FLT you can force the Classic into Float mode.

GF – Ground Fault, See page 22 for more info on ground fault protection.

Got Comm – Indicates a lack of communication between the display and the Classic. Consult Troubleshooting for information.

Insomnia – This, when enabled, will keep the Classic from going to Resting. This is intended for hydro mode only where you may need time to open water valves and do not want to wait for the Classic to wake up.

LED-MODE – This selection lets you pick the function of the 6 visible LEDs on a standard Classic.

LMX – LoMax. This enables the Classic to track the input voltage all the way down to Battery voltage. When disabled the Classic will stop tracking the input around 5 volts above the battery voltage. When the input voltage is within a couple volts of the battery voltage the inductors can “Sing” this is usually not very loud and will do no harm.

MNGP – Midnite Graphical interface Panel. This is the graphical display included with the standard Classic controller.

Mode – This menu lets you turn the charging ability of the controller On / Off as well as lets you select the DC input source. See page 23 for info on the Mode menu.

Mod Bus – a standard protocol used for communications. We have published our protocol to allow users to interface with the Classic. See www.midnitesolar.com for our Mod Bus protocol.

Pwr Save – Allows you to adjust the time the Backlight stays on.

Resting – The Classic is not charging the battery due to low light. For certain reasons Resting will appear. Please see page 24.

T-Comp – Temperature compensation using a temperature sensor to measure the ambient temperature of the battery bank and will adjust the voltage set points up or down accordingly to ensure a full battery. There are 3 parameters to set Minimum and Maximum adjusted voltage as well as volts per degree C per Cell. Typically this is -5 mV but please consult your battery manufacturer. See page 19 for Temperature compensation info.

Tweaks – This menu has all the advanced adjustments for the Classic. For example: Voltage off set adjustments etc.

VBatt – Battery voltage, measured at the battery terminals of the Classic.

VOC – Open Circuit Voltage, unloaded voltage measurement.

Vpv – Input voltage, measured at the input terminals of the Classic.