

DESCRIPTION:
SNAPNRACK, ULTRA RAIL W TILE REPLACEMENT KIT

DRAWN BY:

mwatkins

REVISION:

A

SnapNrack™
Solar Mounting Solutions

PART NUMBER(S):

242-01228

595 MARKET STREET, 29TH FLOOR • SAN FRANCISCO, CA 94105 USA
 PHONE (415) 580-6900 • FAX (415) 580-6902

THE INFORMATION IN THIS DRAWING IS CONFIDENTIAL AND PROPRIETARY. ANY REPRODUCTION, DISCLOSURE, OR USE THEREOF IS PROHIBITED WITHOUT THE WRITTEN CONSENT OF SUNRUN SOUTH LLC.

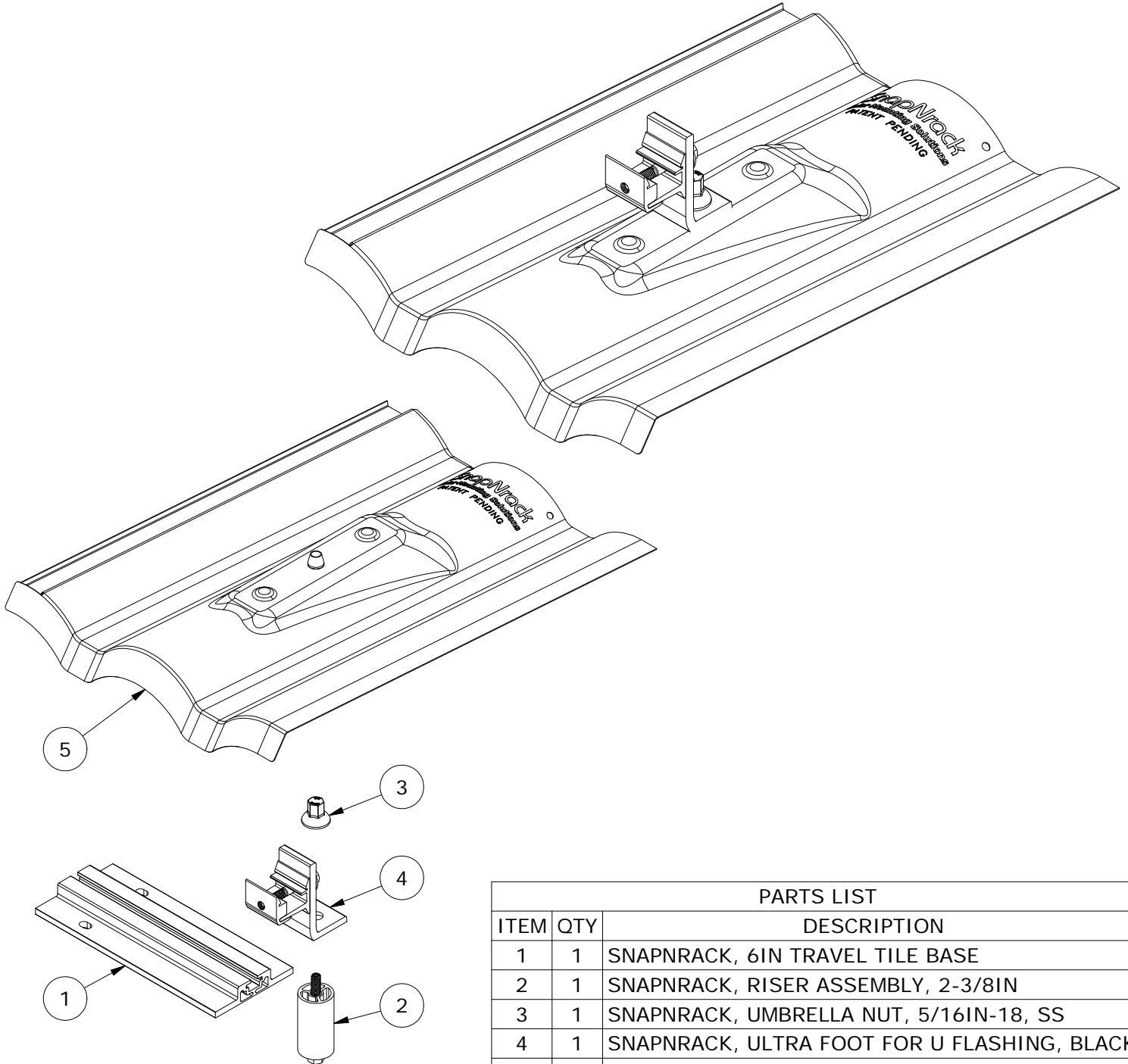

PARTS LIST

ITEM	QTY	DESCRIPTION
1	1	SNAPNRACK, 6IN TRAVEL TILE BASE
2	1	SNAPNRACK, RISER ASSEMBLY, 2-3/8IN
3	1	SNAPNRACK, UMBRELLA NUT, 5/16IN-18, SS
4	1	SNAPNRACK, ULTRA FOOT FOR U FLASHING, BLACK
5	1	SNAPNRACK, W TILE REPLACEMENT

MATERIALS: 6000 SERIES ALUMINUM, DEAD SOFT ALUMINUM, STAINLESS STEEL

DESIGN LOAD (LBS): 445 UP, 1333 DOWN, 93 SIDE

ULTIMATE LOAD (LBS): 1256 UP, 4000 DOWN, 279 SIDE

TORQUE SPECIFICATION: 10 (UMBRELLA NUT), 12 (MOUNT) LB-FT

CERTIFICATION: UL 2703, FILE E359313

WEIGHT (LBS): 2.55

DESCRIPTION:

SNAPNRACK, ULTRA RAIL W TILE REPLACEMENT
KIT

DRAWN BY:

mwatkins

REVISION:

A

SnapNrack™
Solar Mounting Solutions

PART NUMBER(S):

242-01228

595 MARKET STREET, 29TH FLOOR • SAN FRANCISCO, CA 94105 USA
PHONE (415) 580-6900 • FAX (415) 580-6902

THE INFORMATION IN THIS DRAWING IS CONFIDENTIAL AND PROPRIETARY. ANY
REPRODUCTION, DISCLOSURE, OR USE THEREOF IS PROHIBITED WITHOUT THE
WRITTEN CONSENT OF SUNRUN SOUTH LLC.

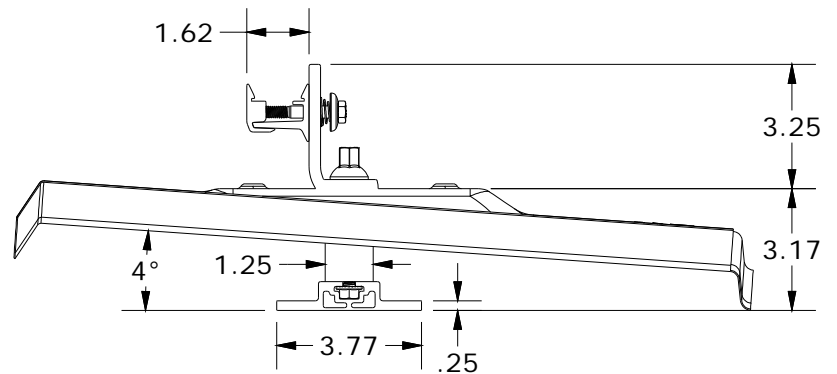
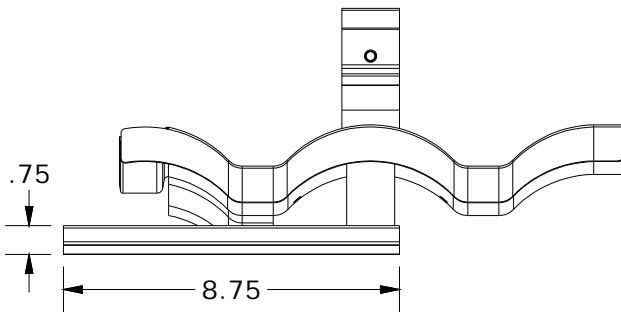
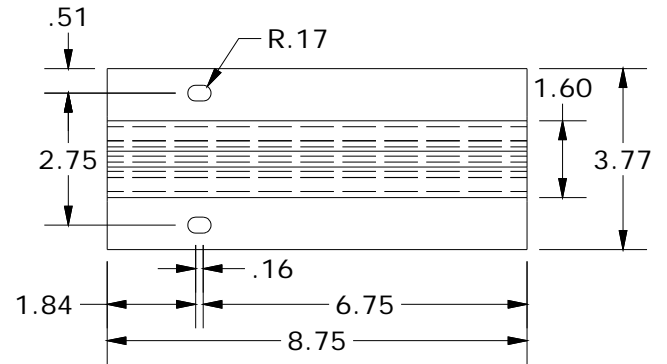
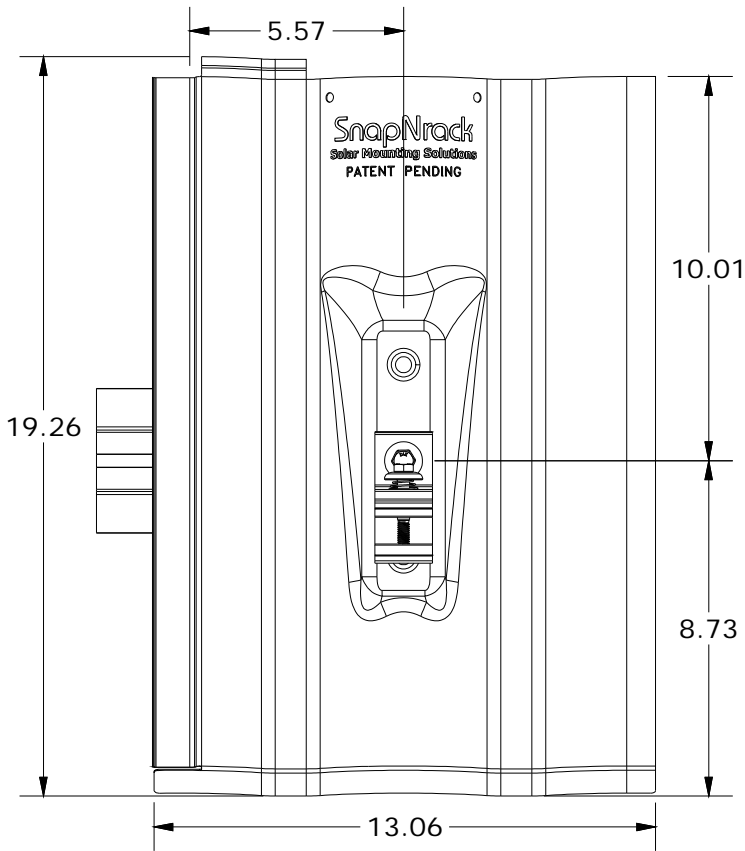

ALL DIMENSIONS IN INCHES